

CAD FILE:

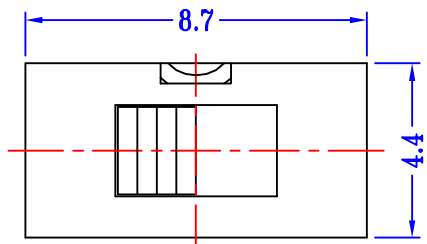

电气性能参数:

1. 额定负载: DC50V 0.3A
2. 接触电阻: 100毫欧以下
3. 绝缘电阻: 100兆欧以上
4. 耐压: AC 500V
5. 力度: 250+100gf
6. 寿命: 8000次
7. 手焊: 350+10度

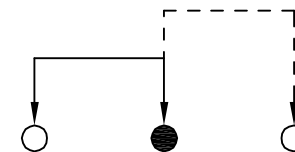

SCHEMATIC (SHORTING)

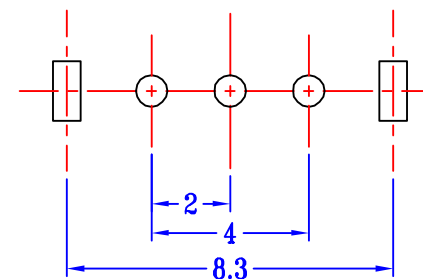
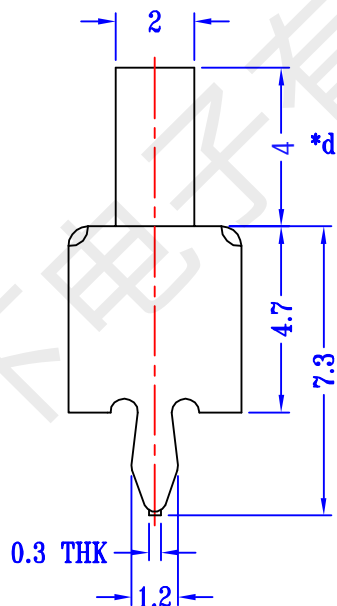
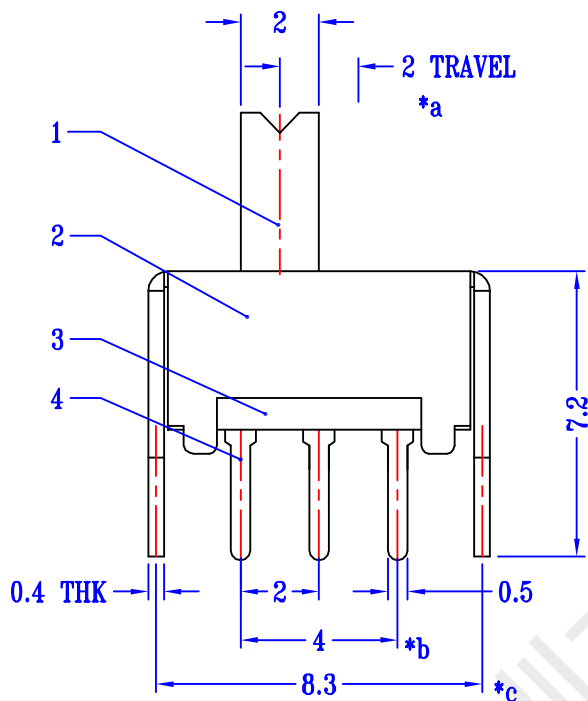

P.C.B LAYOUT
BOTTOM VIEW

注: "*"表示关键尺寸(4个)

NO.	PARTS	MATERIALS	Q'TY	FINISH	TOLERANCE UNLESS SPECIFIED		DESCRIPTIONS OF REVISION		
8					WITHIN 1.5mm	±0.1mm			
7					OVER 1.5mm	±0.2mm	ISSUE	DATE	APPD.
6					TITLE : VERTICAL SLIDE SWITCH				
5	CONTACT CLIP	PBS STRIP	1	Ag CLAD	UNIT : mm				
4	TERMINAL	BRASS STRIP	3	Ag PLATED	DRWG NO.: HR-DR-SS12D07-00				
3	BASE	PHENOLIC RESIN	1	NATURAL	MODEL: SS-12D07VG4				
2	FRAME	STEEL STRIP	1	Ni PLATED	SCALE: 5 : 1				
1	KNOB	POM	1	BLACK	DWN. 黄彬 2020.6.17				
					CHK'D 张伟 2020.6.17				
					APPD. 罗小春 2020.6.17				