

1 2 3 4 5 6 7 8

A
B
C
D
E
F

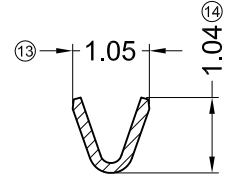
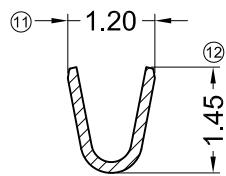
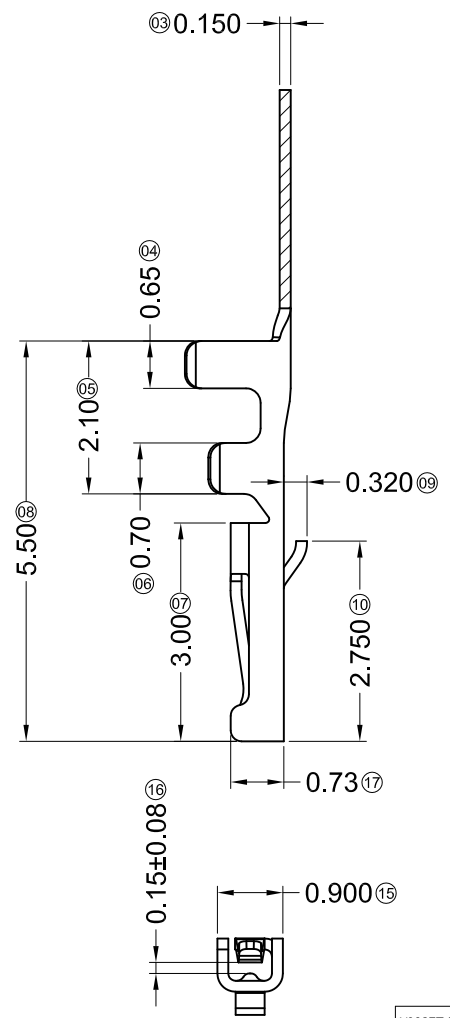
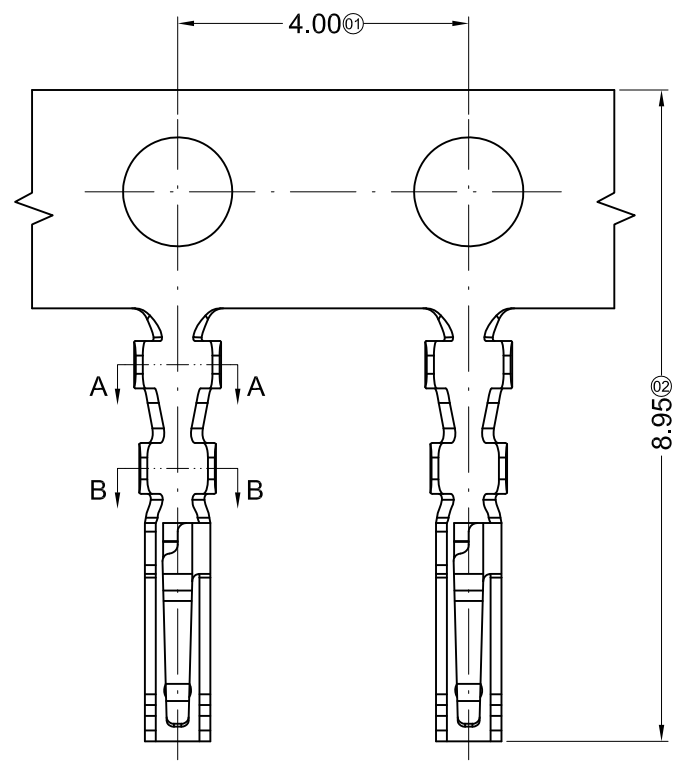

■ Specifications :

- Voltage rating: 125V AC / DC
- Current rating: 1A AC / DC
- Withstanding voltage: 250V AC/minute
- Temperature range: -25°C~+85°C
- Insulation resistance: ≥100MΩ
- Contact resistance: ≤20mΩ
- After environmental testing: ≤40mΩ

X9827 T X-P XX X-X
① ② ③ ④ ⑤ ⑥ ⑦

- ① Series Number
- ② Category: T-terminal
- ③ Shape: Blank-ordinary
- ④ Material: P-Phosphor bronze
- ⑤ Plating style: V01-Gold Flash ; V03-Gold 3u"
SN-Bright tin plating 70u"Min.;
SN1-Bright tin plating 100u"Min.
- ⑥ Plating method: Blank-Stamping before plating
- ⑦ Mold No./Mark/Special No.

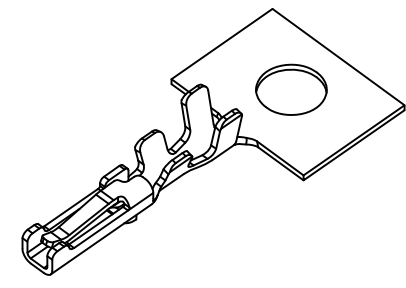

X9827T-PSN1	Phosphor Bronze	AWG#28-32	0.90mm(Max)	Stamping Before Plating:30u" Ni; 100u"Sn Min.	9827H
X9827T-PV01	Phosphor Bronze	AWG#28-32	0.90mm(Max)	Stamping Before Plating:30u" Ni;Whole Gold :Gold Flash	
X9827T-PV03	Phosphor Bronze	AWG#28-32	0.90mm(Max)	Stamping Before Plating:30u" Ni;Whole Gold:3u" Min.	
X9827T-PSN	Phosphor Bronze	AWG#28-32	0.90mm(Max)	Stamping Before Plating:30u" Ni;70u"Sn Min.	
PART NO	Material	Wire Range	Insulation O.D.	Finish	Suitable XKB

For and on behalf of
XKB INDUSTRIAL PRECISION CO., LIMITED
香港星坤工業精密有限公司

△ X					ANGULAR	± 5°
△ X					L ≤ 4	± 0.2
△ X					4 < L ≤ 16	± 0.3
MARK	DESCRIPTION	DATE	REVISED	APPROVED	16 < L ≤ 63	± 0.4
					L > 63	± 0.5
REVISIONS					UNSPECIFIED TOLERANCES	

DSND	DATE	SCALE: N/A	MODEL TYPE: X9827T-PXXX
DWN	DATE	VIEW:	PART NO.:
CHKD	DATE	UNIT: mm	1.25mm Crimp Style Connectors
APPD	DATE	SIZE: A4	DWG NO.:
			WEIGHT
			1.0g
			SHEET
			1/1
			REVISION
			A0

XKB INDUSTRIAL PRECISION CO., LIMITED

1 2 3 4 5 6 7 8