

3W Low EMI Class-D Audio Power Amplifier with Auto-Recovering Short-Circuit Protection

GENERAL DESCRIPTION

The ft2011 is a high efficiency, low EMI, filterless, Class-D audio amplifier with auto-recovering short-circuit protection. It operates from 3V to 5.5V supply. When powered with 5V supply voltage, the ft2011 is capable of delivering 3W into a 4Ω load or 1.8W into an 8Ω load, with 10% THD+N.

As a Class-D audio amplifier, the ft2011 features 90% efficiency and 75dB PSRR at 217Hz which make the device ideal for battery-powered high-quality audio applications.

One of the key benefits of the ft2011 over typical Class-D audio power amplifiers is it generates much less EMI emissions, thus greatly simplifying the system design for portable applications. Also included is the over-current and short-circuit protection with auto-recovery, which ensures the device be operated safely and reliably without the need for system interaction.

APPLICATIONS

- Mobile Phones
- Portable Navigation Devices
- Multimedia Internet Devices
- Portable Speakers

FEATURES

- Filterless Class-D operation
- High efficiency up to 90%
- Maximum output power at 5V supply
3.0W (4Ω load, 10% THD+N)
1.8W (8Ω load, 10% THD+N)
- Maximum output power at 3.6V supply
1.5W (4Ω load, 10% THD+N)
0.9W (8Ω load, 10% THD+N)
- Low THD+N: 0.05%
($V_{DD}=3.6V$, $f=1kHz$, $R_L=8\Omega$, $P_o=0.5W$)
- Low quiescent current: 2mA @ $V_{DD}=3.6V$
- Low shutdown current < 0.1μA
- High PSRR: 75dB @ 217Hz
- No bypass capacitor required for the common-mode bias
- Under-voltage lockout
- Auto-recovering over-current and short-circuit protection
- Thermal overload protection
- Low EMI design
- Available in COL1.5x1.5-9L, SOP-8L, MSOP-8L, and DFN2x2-8L packages

APPLICATION CIRCUIT

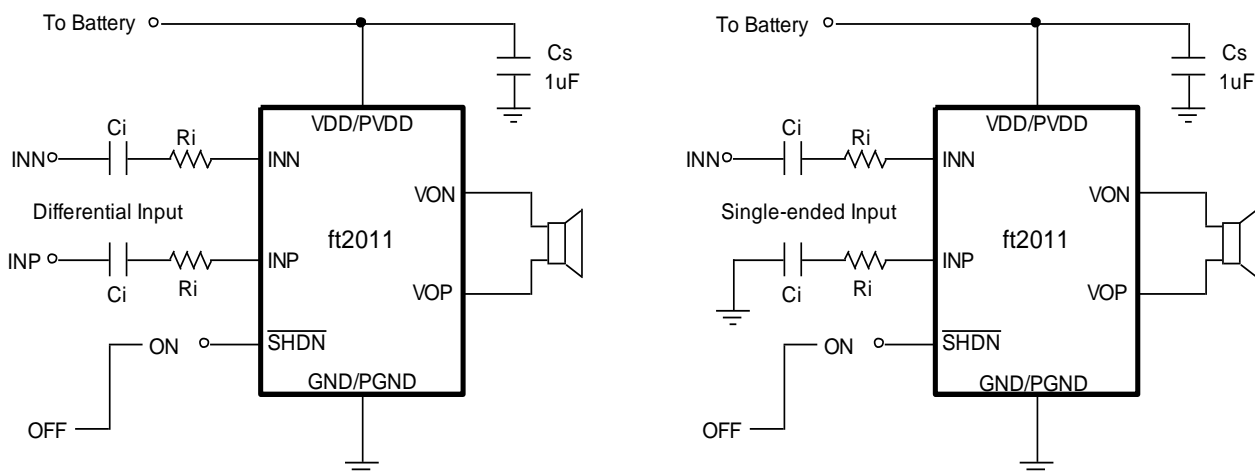
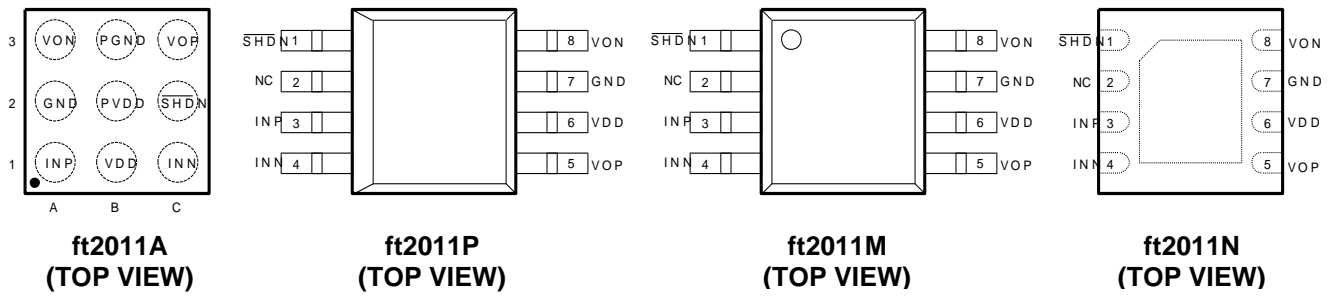

Figure 1: Typical Audio Amplifier Application Circuit

PIN CONFIGURATION AND DESCRIPTION



PIN NAME	PIN NUMBER				DESCRIPTION
	ft2011A	ft2011P	ft2011M	ft2011N	
SHDN	C2	1	1	1	Active low shutdown control.
NC		2	2	2	No internal connection.
INP	A1	3	3	3	Positive audio input terminal.
INN	C1	4	4	4	Negative audio input terminal.
VOP	C3	5	5	5	Positive BTL audio output terminal.
VDD	B1	6	6	6	Power supply.
PVDD	B2				Power supply for the output stage. For ft2011P/M/N, it is internally shorted to VDD. For 2011A, it must be externally shorted to VDD on the system board.
GND	A2	7	7	7	Ground.
PGND	B3				Power ground for the output stage. For ft2011P/M/N, it is internally shorted to GND. For 2011A, it must be externally shorted to GND on the system board.
VON	A3	8	8	8	Negative BTL audio output terminal.

ORDERING INFORMATION

PART NUMBER	TEMPERATURE RANGE	PACKAGE
ft2011A	-40°C to +85°C	COL1.5x1.5-9L
ft2011P	-40°C to +85°C	SOP-8L
ft2011M	-40°C to +85°C	MSOP-8L
ft2011N	-40°C to +85°C	DFN2x2-8L

ABSOLUTE MAXIMUM RATINGS

PARAMETER	UNIT
Supply Voltage	-0.3V to 6.0V
All Other Pins	-0.3V to VDD+0.3V
Power Dissipation	Internally Limited
ESD Rating (HBM)	4000V
Junction Temperature	150°C
Storage Temperature	-45°C to 150°C
Soldering Information	
Vapor Phase (60 sec.)	215°C
Infrared (15 sec.)	220°C

Note: Stresses beyond those listed under absolute maximum ratings may cause permanent damage to the device. These are stress ratings only, and functional operation of the device at these or any other conditions beyond those indicated under recommended operating conditions is not implied. Exposure to absolute-maximum-rated conditions for extended periods may affect device reliability.

PACKAGE DISSIPATION RATINGS

PACKAGE	θ_{JA}	UNIT
COL1.5x1.5-9L	190	°C/W
SOP-8L	140	°C/W
MSOP-8L	180	°C/W
DFN2x2-8L	100	°C/W

RECOMMENDED OPERATING CONDITIONS

PARAMETER	CONDITIONS	MIN	TYP	MAX	UNIT
Supply Voltage, VDD		3		5.5	V
Operating Free-Air Temperature, TA		-40		85	°C
Minimum Load Resistance, RLOAD		3.2			Ω

IMPORTANT APPLICATION NOTES

1. The ft2011, as a Class-D power audio amplifier, requires adequate power supply decoupling to ensure its optimum performance such as output power, efficiency, and THD+N. Place decoupling capacitors as close to the VDD pin as possible. For applications where the load resistance is less than 6 Ω , it is strongly recommended to use a 4.7 μ F to 10 μ F capacitor for power supply decoupling.
2. It is recommended to employ a ground plane for ft2011 on the system board.
3. Use a simple ferrite bead filter for further EMI suppression. Choose a ferrite bead with a rated current no less than 2A or greater for applications with a load resistance less than 6 Ω . Also, place the respective ferrite bead filters as close to the output pins, VOP and VON, as possible.
4. For applications where the power supply is rated more than 4.6V or the load resistance less than 6 Ω , it is strongly recommended to add a simple snubber circuit (as shown in Figure 23) between the two output pins, VOP and VON, to prevent the device from accelerated deterioration or abrupt destruction due to excessive inductive flybacks that are induced on fast output switching or by an over-current or short-circuit condition.

FUNCTIONAL BLOCK DIAGRAM

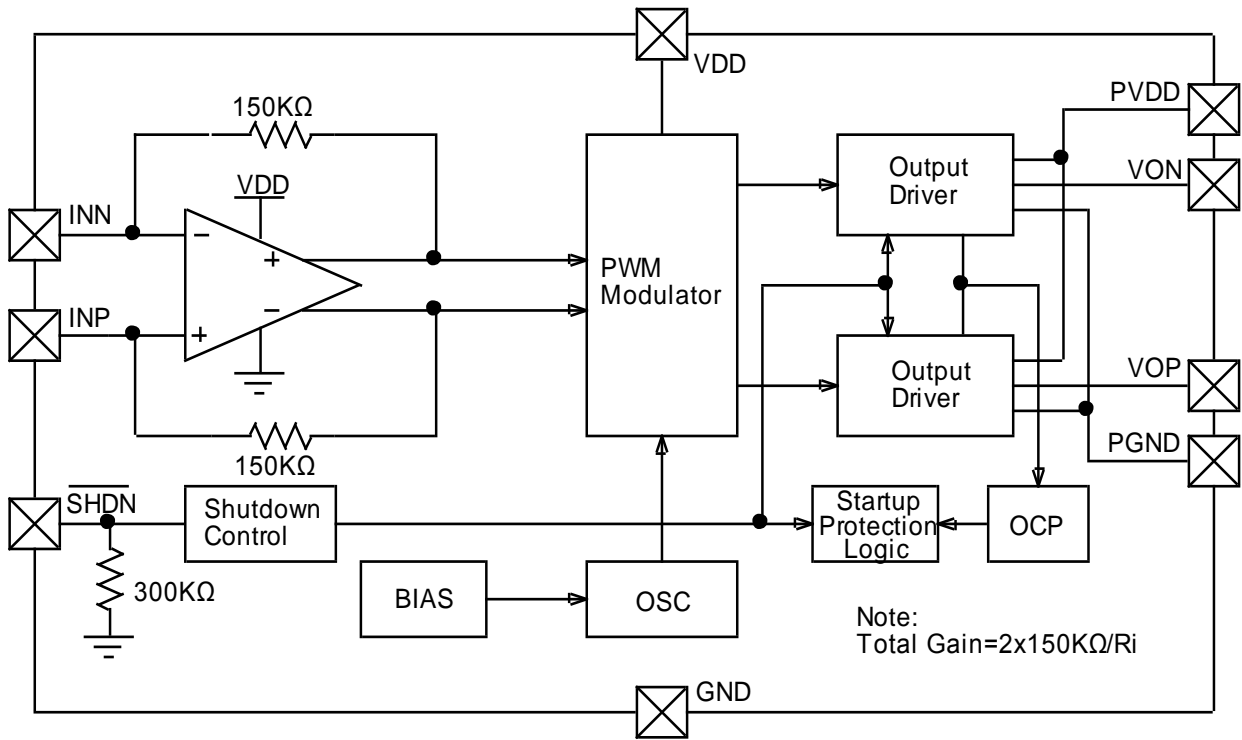

Figure 2: Simplified Function Block Diagram of ft2011

ELECTRICAL CHARACTERISTICS

$T_A=25^{\circ}\text{C}$, $V_{DD} = 3.6\text{V}$, $R_L=8\Omega$, Gain = 2V/V , $R_i=150\text{k}\Omega$, $C_i=0.1\mu\text{F}$, $f=1\text{kHz}$, unless otherwise noted.

SYMBOL	PARAMETER	CONDITIONS	MIN	TYP	MAX	UNIT
V_{DD}	Supply Voltage		3.0		5.5	V
V_{UVLU}	Power Up Threshold Voltage	VDD from Low to High		2.2		V
V_{UVLD}	Power Down Threshold Voltage	VDD from High to Low		2.0		V
I_{DD}	Quiescent Current	VDD=5V, No Load Inputs AC-Grounded	1.5	2.2	4.0	mA
		VDD=3.6V, No Load Inputs AC-Grounded	1.4	2.0	3.6	mA
I_{SD}	Shutdown Current	$\overline{\text{SHDN}}$ Low		0.1		μA
V_{SDIH}	$\overline{\text{SHDN}}$ Input High		1.3			V
V_{SDIL}	$\overline{\text{SHDN}}$ Input Low				0.4	V
P_O	Maximum Output Power VDD=5V, Load=8 Ω	THD+N=10%		1.8		W
		THD+N=1%		1.4		
	Maximum Output Power VDD=3.6V, Load=8 Ω	THD+N=10%		0.9		W
		THD+N=1%		0.7		
P_O	Maximum Output Power VDD=5V, Load=4 Ω	THD+N=10%		3.0		W
		THD+N=1%		2.4		
	Maximum Output Power VDD=3.6V, Load=4 Ω	THD+N=10%		1.5		W
		THD+N=1%		1.2		
A_v	Gain			300k Ω / R_i		V/V
R_o	Output Resistance in Shutdown	$\overline{\text{SHDN}}$ Low		2		k Ω
R_{SHDN}	$\overline{\text{SHDN}}$ Input Resistance			300		k Ω
V_{REF}	VREF Voltage			VDD/2		V
THD+N	Total Harmonic Distortion + Noise Load=8 Ω	VDD=3.6V, $P_o=0.5\text{W}$		0.05		%
		VDD=5V, $P_o=1\text{W}$		0.07		
	Total Harmonic Distortion + Noise Load=4 Ω	VDD=3.6V, $P_o=1\text{W}$		0.06		%
		VDD=5V, $P_o=2\text{W}$		0.08		
V_N	Output Voltage Noise	Bandwidth = 20Hz ~ 20kHz Inputs AC-Grounded		85		μVRMS
V_{OS}	Output Offset Voltage	Inputs AC-Grounded		± 5		mV
η	Efficiency	VDD=5V, $P_o=1\text{W}$		90		%
PSRR	Power Supply Rejection Ratio	f=217Hz		75		dB
CMRR	Common Mode Rejection Ratio			70		dB
T_{STUP}	Startup Time			35		ms
f_{PWM}	PWM Carrier Frequency			800		kHz
f_{JITTER}	PWM Frequency Jittering Range			± 24		kHz
I_{LIMIT}	Over-Current Threshold	VDD=5V		2.0		A
T_{OTP}	Over-Temperature Threshold			160		$^{\circ}\text{C}$
T_{HYS}	Over-Temperature Hysteresis			30		$^{\circ}\text{C}$

TEST SETUP FOR PERFORMANCE TESTING

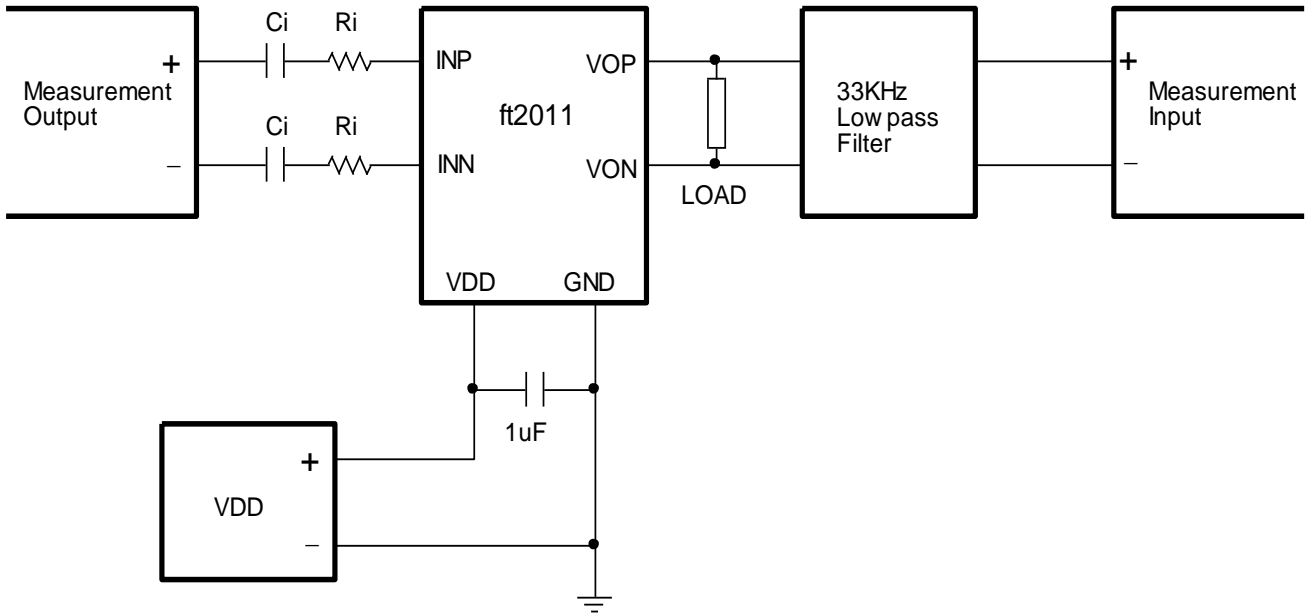

Figure 3: Test Block Diagram

Notes: 1) A 33μH inductor is placed in series with the load resistor to emulate a small speaker for efficiency measurements;
 2) The 33kHz lowpass filter is added onto the audio outputs, VOP and VON even if the analyzer has an internal lowpass filter. An RC lowpass filter (100Ω, 47nF) is used on each output for the data sheet graphs.

TYPICAL PERFORMANCE CHARACTERISTICS

$T_A=25^{\circ}\text{C}$, $V_{DD} = 3.6\text{V}$, Gain = 2V/V, $R_L=150\text{k}\Omega$, $C_I=0.1\mu\text{F}$, $f=1\text{kHz}$, ft2011M, unless otherwise noted.

List of Performance Characteristics

DESCRIPTION	CONDITIONS	FIGURE #
Output Power vs. Supply Voltage	$R_L=4\Omega+33\mu\text{H}$, THD+N=1% & 10%	4
	$R_L=8\Omega+33\mu\text{H}$, THD+N=1% & 10%	5
Output Power vs. Input Voltage	$V_{DD}=5.0\text{V}$, $R_L=4\Omega+33\mu\text{H}$ & $8\Omega+33\mu\text{H}$	6
Quiescent Current vs. Supply Voltage	Input AC-Grounded, No Load	7
Efficiency vs. Output Power	$V_{DD}=5.0\text{V}$, $R_L=8\Omega+33\mu\text{H}$	8
	$V_{DD}=3.6\text{V}$, $R_L=8\Omega+33\mu\text{H}$	9
	$V_{DD}=5.0\text{V}$, $R_L=4\Omega+33\mu\text{H}$,	10
	$V_{DD}=3.6\text{V}$, $R_L=4\Omega+33\mu\text{H}$	11
THD+N vs. Output Power	$V_{DD}=5.0\text{V}$, $R_L=8\Omega+33\mu\text{H}$	12
	$V_{DD}=3.6\text{V}$, $R_L=8\Omega+33\mu\text{H}$	13
	$V_{DD}=5.0\text{V}$, $R_L=4\Omega+33\mu\text{H}$	14
	$V_{DD}=3.6\text{V}$, $R_L=4\Omega+33\mu\text{H}$	15
THD+N vs. Frequency	$V_{DD}=5.0\text{V}$, $P_o=1\text{W}$, $R_L=4\Omega+33\mu\text{H}$ & $8\Omega+33\mu\text{H}$	16
	$V_{DD}=3.6\text{V}$, $P_o=0.5\text{W}$, $R_L=4\Omega+33\mu\text{H}$ & $8\Omega+33\mu\text{H}$	17
PSRR vs. Input Frequency	$V_{DD}=4.0\text{V}$, $R_L=8\Omega+33\mu\text{H}$, Input AC-Grounded	18
Auto-Recovering SCP Waveforms	$V_{DD}=4.0\text{V}$, $R_L=8\Omega+33\mu\text{H}$, $V_{in}=0.1\text{VRMS}$	19
Broadband Output Spectrum	$V_{DD}=4.0\text{V}$, No Load, $V_{in}=0.25\text{VRMS}$	20
Audio-Band Output Spectrum	$V_{DD}=4.0\text{V}$, No Load, $V_{in}=0.25\text{VRMS}$	21

TYPICAL PERFORMANCE CHARACTERISTICS (Cont'd)

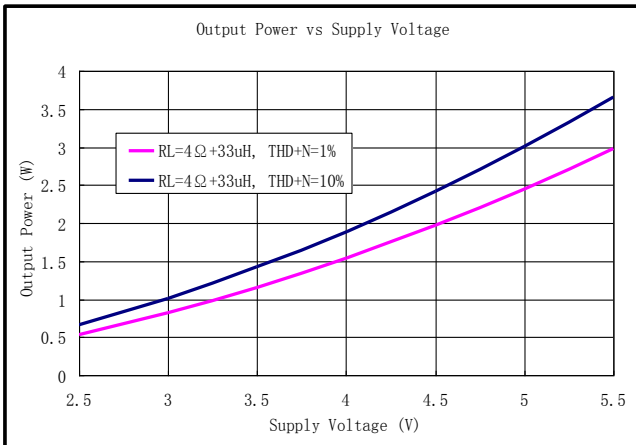

Figure 4: Output Power vs. Supply Voltage

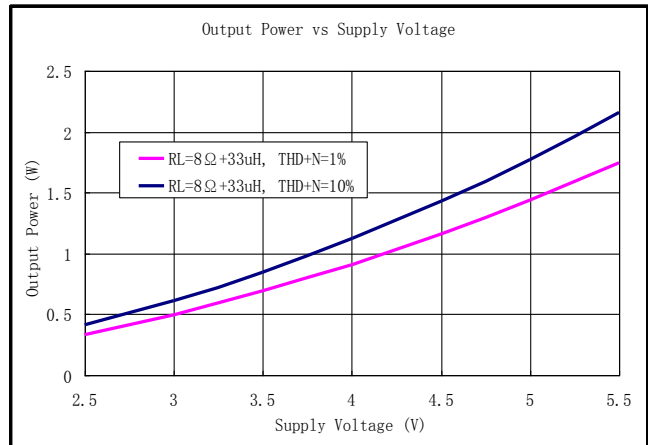

Figure 5: Output Power vs. Supply Voltage

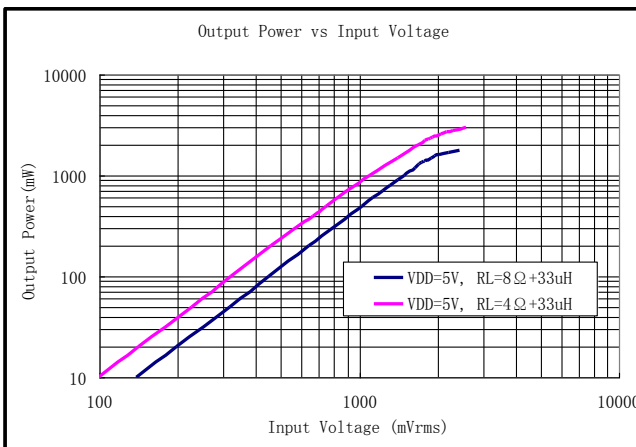

Figure 6: Output Power vs. Input Voltage

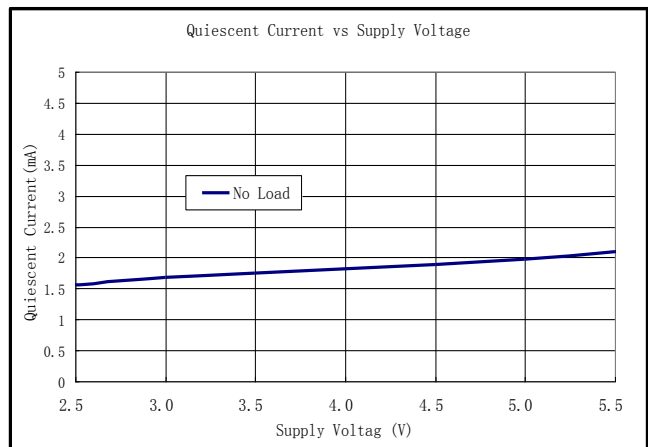

Figure 7: Quiescent Current vs. Supply Voltage

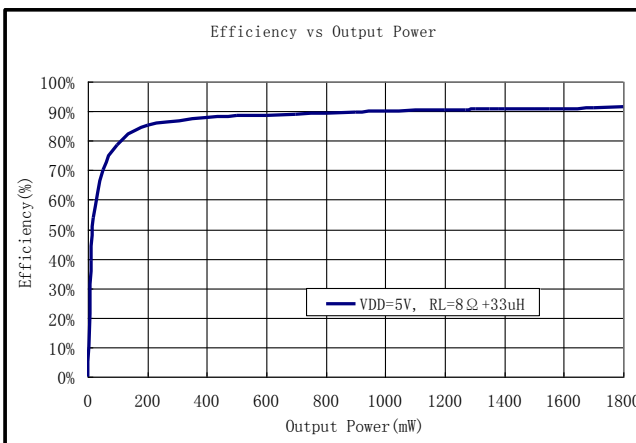

Figure 8: Efficiency vs. Output Power

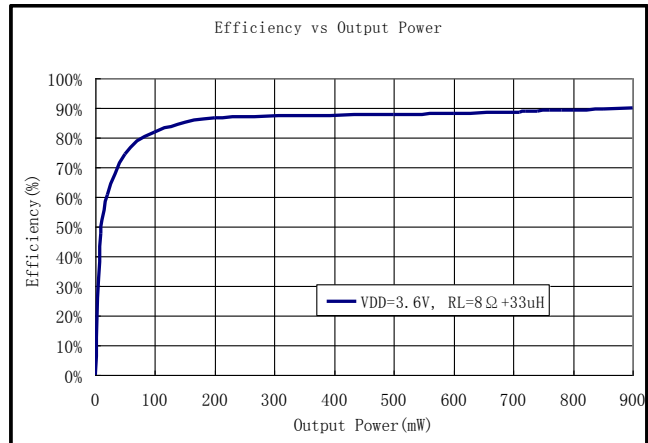

Figure 9: Efficiency vs. Output Power

TYPICAL PERFORMANCE CHARACTERISTICS (Cont'd)

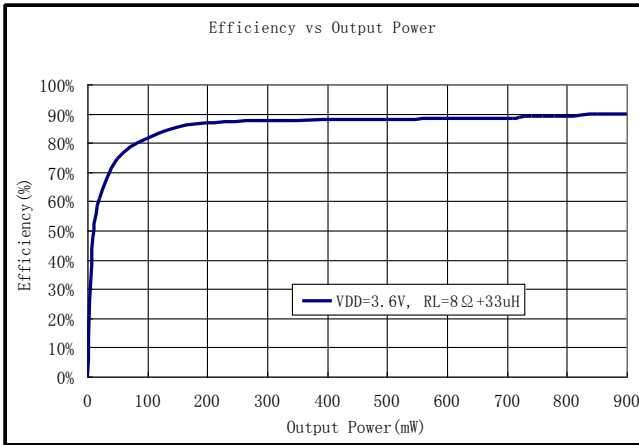

Figure 10: Efficiency vs. Output Power

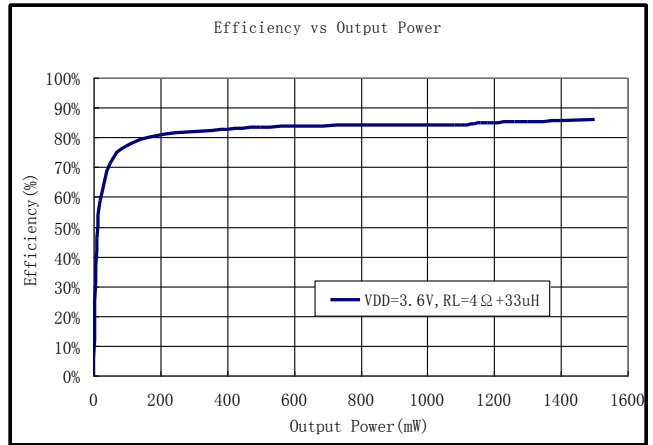

Figure 11: Efficiency vs. Output Power

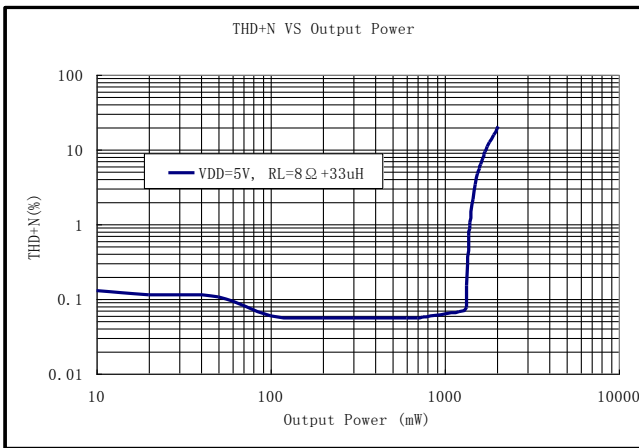

Figure 12: THD+N vs. Output Power

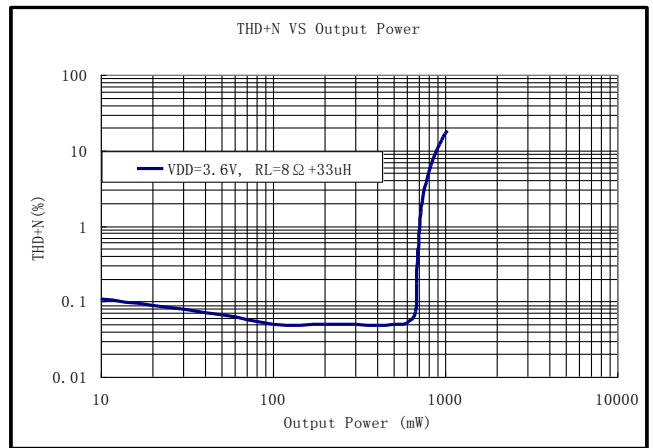

Figure 13: THD+N vs. Output Power

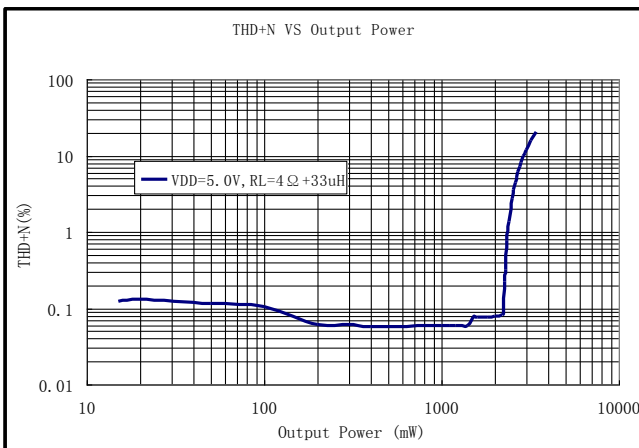

Figure 14: THD+N vs. Output Power

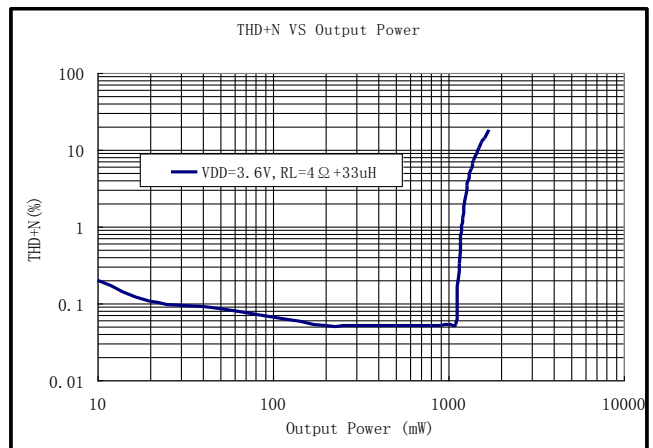

Figure 15: THD+N vs. Output Power

TYPICAL PERFORMANCE CHARACTERISTICS (Cont'd)

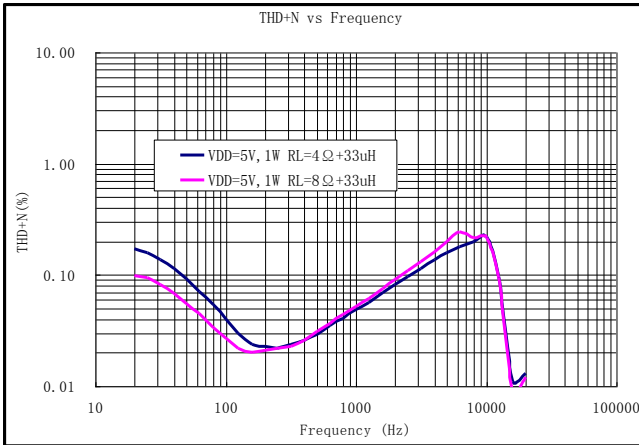

Figure 16: THD+N vs. Frequency

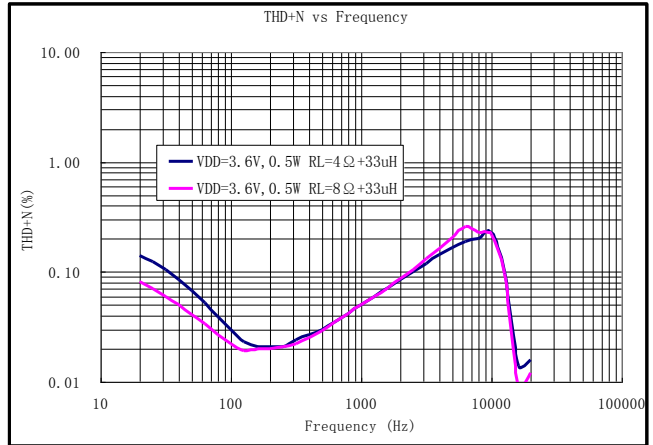

Figure 17: THD+N vs. Frequency

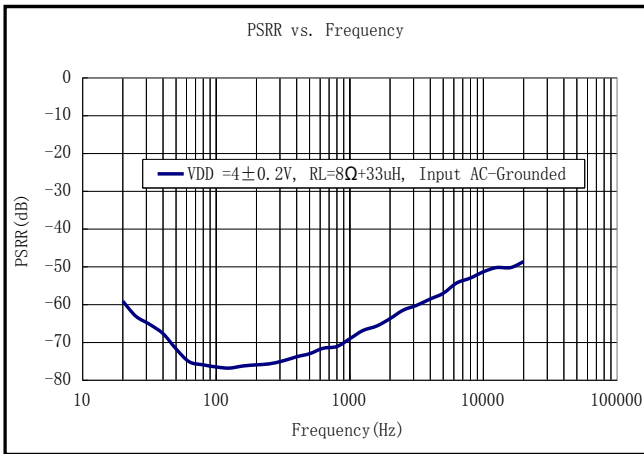

Figure 18: PSRR vs. Frequency

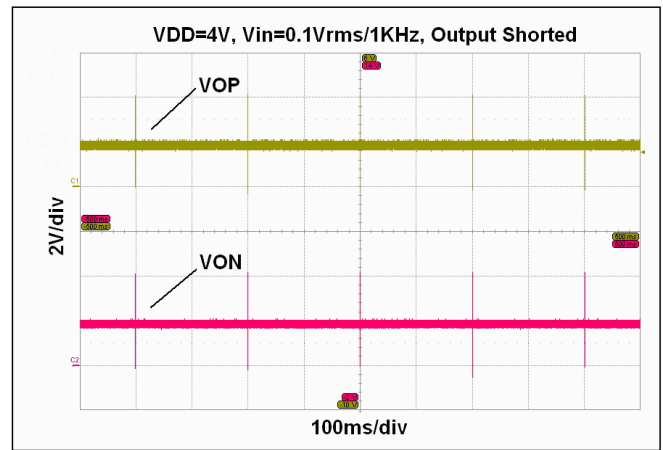

Figure 19: Auto Recovering SCP Waveforms

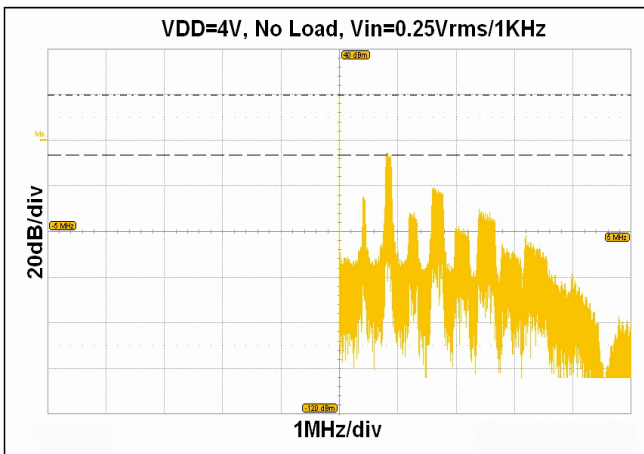

Figure 20: Broadband Output Spectrum

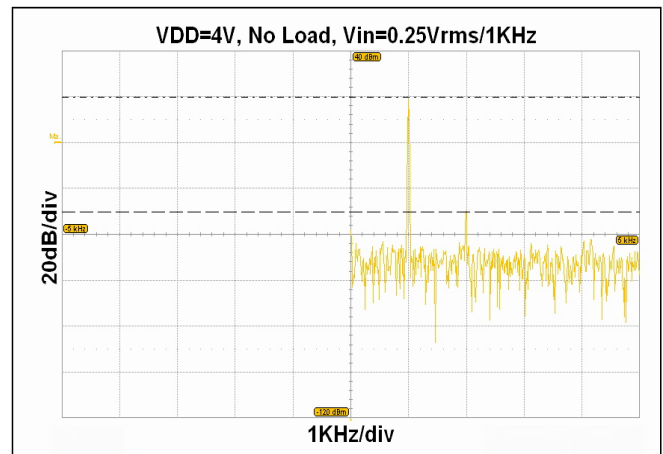

Figure 21: Audio-Band Output Spectrum

APPLICATION INFORMATION

The ft2011 is a high efficiency, low EMI, filterless, Class-D audio power amplifier with auto-recovering short-circuit protection. The ft2011 operates from 3V to 5.5V supply. When powered with 5V supply voltage, the ft2011 is capable of delivering up to 3W into a 4Ω load or 1.8W into an 8Ω load, with 10% THD+N.

As a Class-D power audio amplifier, the ft2011 features 90% high efficiency and 75dB PSRR at 217Hz which make the device ideal for battery-supplied, high-quality audio applications. One of the key benefits of the ft2011 over typical Class-D audio power amplifiers is it generates much less EMI emissions, thus greatly simplifying the system design for portable applications. Also included are the circuitry to minimize turn-on and turn-off transients (also known as pops and clicks) and auto-recovering over-current protection (OCP) and short-circuit protection (SCP).

Furthermore, the ft2011 includes under-voltage lockout to ensure proper operation when the device is first powered up; and thermal-overload protection to safeguard the die temperature during operation.

Fully Differential Amplifier

The ft2011 is configured in a fully differential topology. The fully differential topology ensures that the amplifier outputs a differential voltage on the output that is equal to the differential input times the gain. The common-mode feedback ensures that the common-mode voltage at the output is biased around VDD/2 regardless of the common-mode voltage at the input. Although the fully differential topology of the ft2011 can still be used with a single-ended input, it is highly recommended that the ft2011 be used with differential inputs in a noisy environment, like a wireless handset, to ensure maximum noise rejection.

Filterless Design

Traditional Class-D amplifiers require an output filter. The filter adds cost and the size of the system board. Furthermore, it degrades the performance of power efficiency and THD+N. The ft2011's filterless modulation scheme does not require an output filter. Because the switching frequency of the ft2011 is well beyond the bandwidth of most speakers, voice coil movement due to the switching frequency is very small. Use a speaker with a series inductance larger than 10μH. An 8Ω speaker typically exhibits a series inductance in the range from 20μH to 100μH.

However, LC filter is required when the trace between the ft2011 and the speaker exceeds 100mm. Long trace acts like tiny antenna and generates EMI emissions which may result in FCC and CE certification failures.

Low EMI Design

Traditional Class-D amplifiers require the use of external LC filters or shielding to minimize EMI emissions. The ft2011 employs a proprietary design of the amplifier output stage in conjunction with frequency jittering technique to minimize EMI emissions while maintaining high efficiency.

How to Reduce EMI

The ft2011 does not require an LC output filter for short connections from the amplifier to the speaker. However, additional EMI suppressions can be made by use of a ferrite bead in conjunction with a capacitor, as shown in Figure 22. Choose a ferrite bead with low DC resistance (DCR) and high impedance (100Ω ~ 330Ω) at high frequencies (>100MHz). The current flowing through the ferrite bead must be also taken into consideration. The effectiveness of ferrites can be greatly aggravated at much lower than the rated current values. Choose a ferrite bead with a rated current value no less than 2A. The capacitor value varies based on the ferrite bead chosen and the actual speaker lead length. Choose a capacitor less than 1nF based on EMI performance.

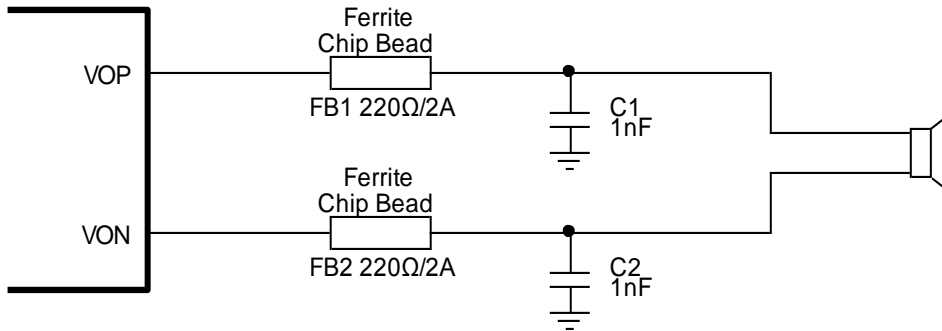

Figure 22: Ferrite Bead Filter to Reduce EMI

RC Snubber Circuit

For applications where the power supply is rated more than 4.6V or the load resistance less than 6Ω, it may become necessary to add an RC snubber circuit between the two output pins, VOP and VON, for robustness and reliability. Figure 23 shows a simple RC snubber circuit, which can be used to prevent the device from accelerated deterioration or abrupt destruction due to excessive inductive flybacks that are induced on fast output switching or by an over-current or short-circuit condition.

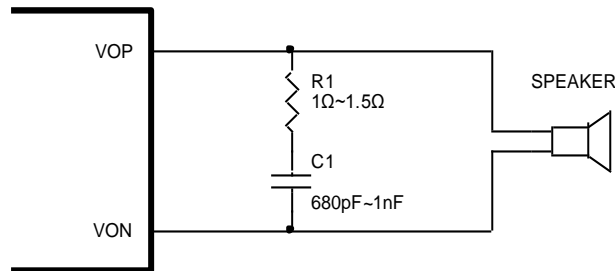

Figure 23: RC Snubber Circuit

Shutdown Operation

In order to reduce power consumption while the device is not in use, the ft2011 includes shutdown circuitry to de-bias all the internal circuitry when the SHDN pin is pulled low. During shutdown, the supply current of the ft2011 is reduced less than 0.1μA, typically.

Under Voltage Lockout (UVLO)

The ft2011 incorporates circuitry designed to detect a low supply voltage. When the supply voltage drops below 2.0V (typical), the ft2011 goes into shutdown mode. The device will emerge out of the shutdown mode and resume its normal operation only when the supply voltage is restored to above 2.2V (typical) and the SHDN pin pulled high.

Auto-Recovering Over-Current Protection (OCP) & Short-Circuit Protection (SCP)

Once an over-current or a short-circuit condition at the differential outputs, either to the power supply or to ground or to each other, is detected, the ft2011 goes into shutdown mode. During shutdown, the ft2011 activates auto-recovering process whose aim is to return the device to normal operation once the fault condition is removed. This process repeatedly examines if the fault condition persists, and returns the device to normal operation immediately after the fault condition is removed. This feature helps protect the device from large currents and maintain long-term reliability while removing the need for external system interaction to resume normal operation.

Over-Temperature Shutdown (OTSD)

The thermal-overload protection on the ft2011 prevents the device from being damaged when the die temperature exceeds 160°C. Once the die temperature exceeds the prescribed value, the device will be forced into shutdown mode and the outputs are disabled. Note that this is not a latched fault. Instead, the thermal fault will be cleared once the temperature of the die is lowered by 30°C. This large hysteresis will prevent it from generating motor boating sound and allow the device resume normal operation without the need for external system interaction.

POP and Click Circuitry

The ft2011 includes circuitry to minimize turn-on and turn-off transients or “pops and clicks”. Here the turn-on refers to either the application of the power supply or the device enabled by asserting SHDN high and turn-off refers to either the removal of the power supply or the device shut down by pulling SHDN low. When the device is first turned on, the amplifier is forced into mute mode initially. An internal current source ramps up the internal reference voltage. The device will remain in the mute mode until the reference voltage reaches to one half of the supply voltage, 1/2 VDD. As soon as the reference voltage reaches to a value substantially close to its final value, the device will begin its normal operation. For the best power-off pop performance, the amplifier should be placed in shutdown mode prior to removing the power supply voltage.

Input Resistors (R_I)

The input resistors (R_I) set the gain of the amplifier according to Equation 1.

$$\text{Gain} = \frac{2 \times 150\text{k}\Omega}{R_I} \left(\frac{V}{V} \right) \quad (1)$$

The matching of the input resistors is a crucial consideration for a fully differential amplifier. The balance of the differential outputs with respect to the common-mode voltage strongly depends on the matching of the input resistors. The CMRR, PSRR, and the cancellation of the even-order harmonics will be significantly degraded if the mismatch of the input resist occurs. Therefore, it is recommended to use the resistors with 1% tolerance or better to keep the performance optimized. Note that the matching tolerance of the input resistors is much more important than the absolute tolerance. Place the input resistors as close to the ft2011 as possible to minimize the noise injected onto the high-impedance input nodes.

Decoupling Capacitor (C_s)

The decoupling capacitor stabilizes the power supply voltage applied onto the ft2011, thus improving its THD performance. It also prevents annoying voltage ringing with a long lead. A capacitor of 1μF or greater with low equivalent-series-resistance (ESR) is required for decoupling and to be placed as close to the ft2011 as possible to minimize the resistance and inductance of the traces between the device and the capacitor. To filter out lower-frequency noise, a capacitor of 10μF or greater should be placed close to the ft2011.

Input Capacitors (C_I)

The input capacitors and input resistors determine the corner frequency of the highpass filter. The corner frequency (f_c) is calculated with the Equation 2.

$$f_c = \frac{1}{(2\pi R_I C_I)} \quad (2)$$

The corner frequency directly influences the low frequency signals and consequently determines output bass quality.

PCB Layout

As the output power increases, the interconnect resistance (PCB traces and wires) among the audio amplifier, load, and power supply creates a voltage drop. The voltage loss on the traces between the ft2011 and the load results in lower output power and lower efficiency. The higher trace resistance between the supply and the ft2011 has the same effect as a poorly regulated supply, increasing the voltage ripples on the supply line and also reducing the peak output power. The effect of the residual trace resistance will be intensified as the output current increases. To maintain the highest output voltage swing for a maximum output power, the PCB traces that connect the output pins to the load and the supply pins to the power supply should be as wide and short as possible to minimize trace resistance.

The use of power and ground planes will give the best THD+N performance. While reducing trace resistance, the use of power planes also creates parasite capacitors that help filter the power supply line.

The inductive nature of the speakers can also result in overshoots on one or both edges, clamped by the parasitic diodes to ground and VDD in each case. From an EMI standpoint, this is the highly unfavorable waveform that will radiate or conduct to other components on the system board and cause interference. It is essential to keep the power and output traces short and well shielded if possible. Use of ground planes, beads, and micro-strip layout techniques are all useful in preventing unwanted interference.

As the distance from the ft2011 to the speaker increases, the amount of EMI radiation will increase since the output wires or traces acting as antenna become more efficient with their lengths. What is acceptable EMI is highly application specific. Ferrite beads placed close to the ft2011 may be needed to reduce EMI radiation. The value of the ferrite beads is also application specific.

TYPICAL APPLICATION CIRCUITS

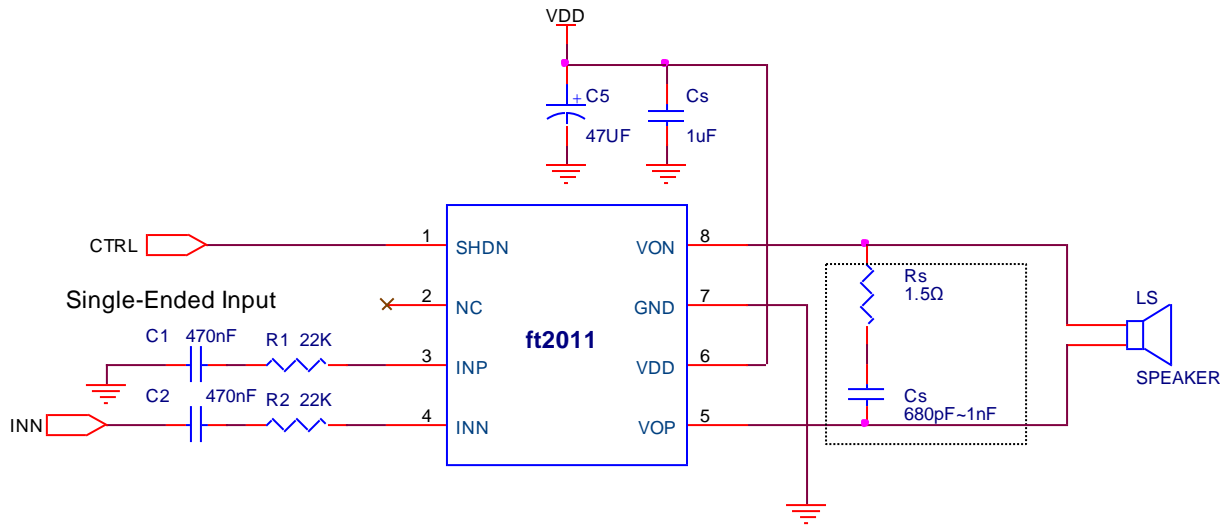

Figure 24: Single-Ended Audio Inputs (SOP-8L Package for Portable Speaker Application)

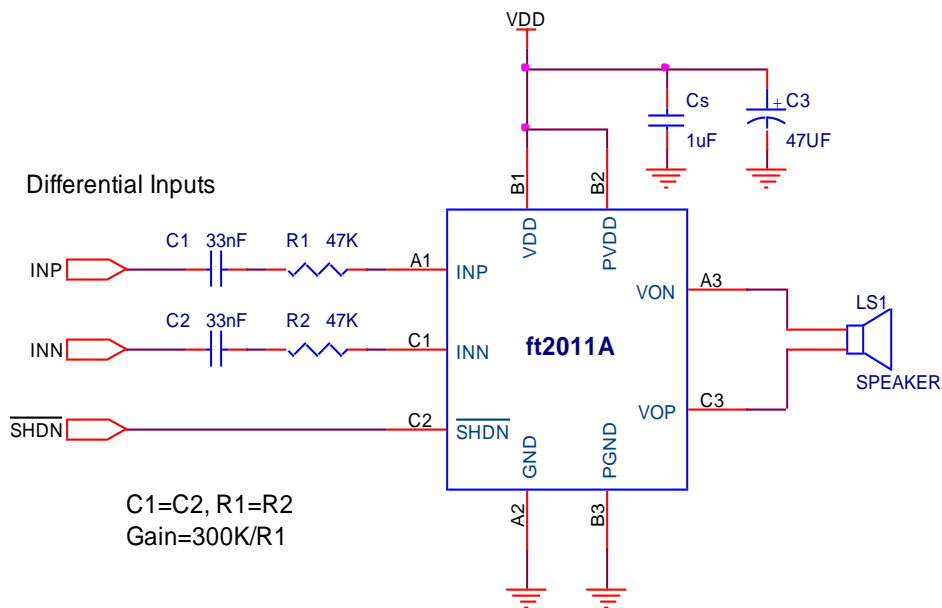

Figure 25: Differential Audio Input (COL-8L Package for Mobile Phone Application)

TYPICAL APPLICATION CIRCUITS (Cont'd)

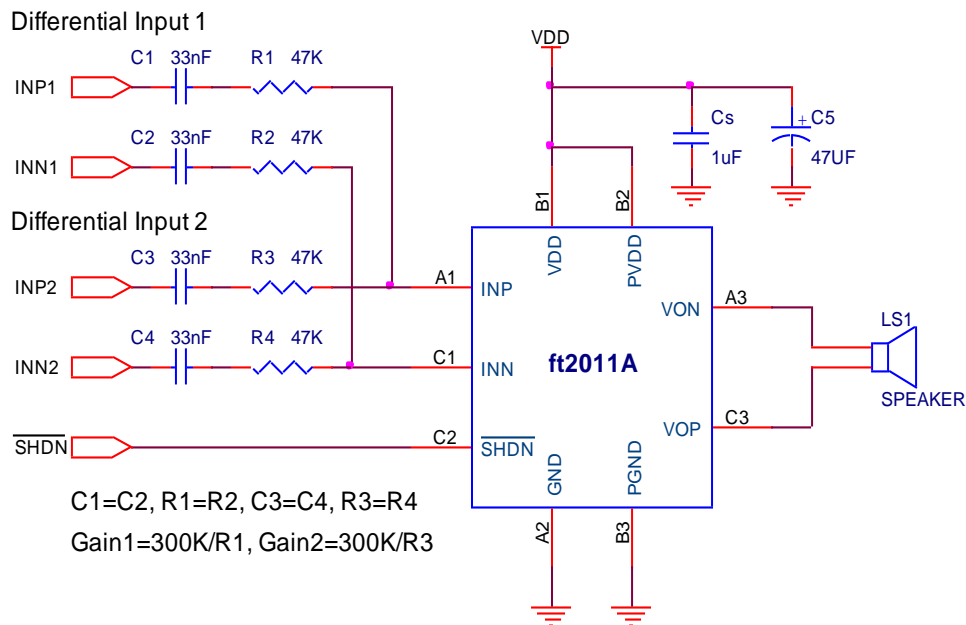

Figure 26: Summing Two Differential Audio Inputs

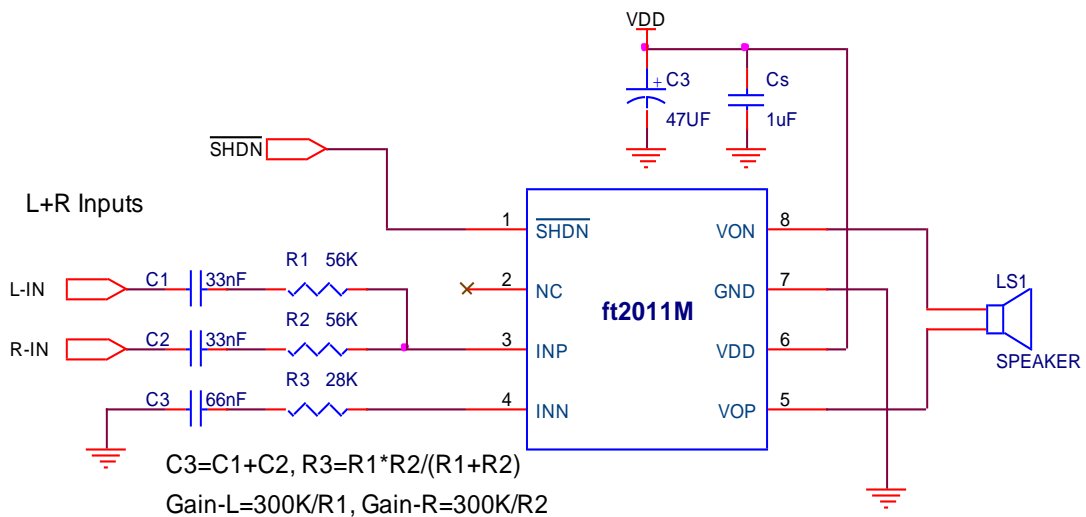
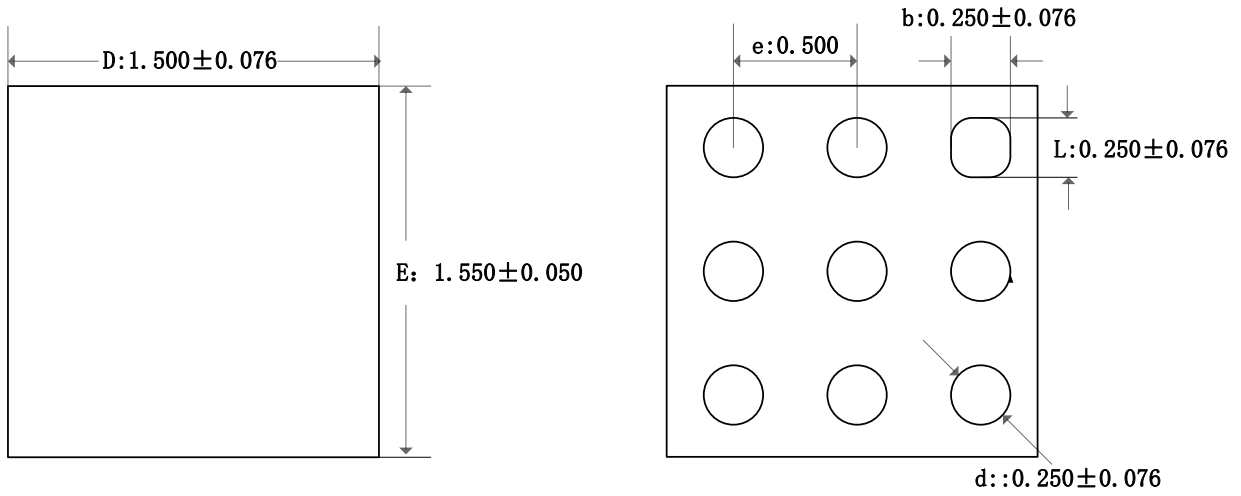

Figure 27: Summing Two Single-Ended Audio Inputs (MSOP-8L Package for MID Application)

PHYSICAL DIMENSIONS

COL1.5X1.5-9L PACKAGE OUTLINE DIMENSIONS



Top View

Bottom View

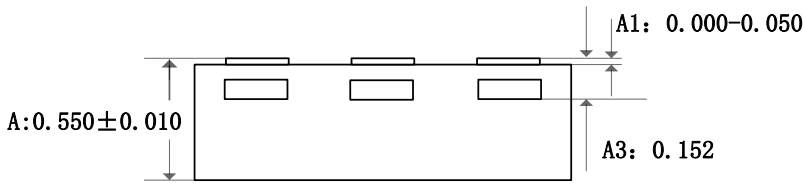

Side View

All dimensions are in millimeters

Symbol	Dimensions in Millimeters		Dimensions in Inches	
	Min.	Max.	Min.	Max.
A	0.450/0.550	0.550/0.650	0.018/0.022	0.022/0.026
A1	0.000	0.050	0.000	0.002
A3	0.152REF.		0.006REF.	
D	1.424	1.576	0.056	0.062
E	1.424	1.576	0.056	0.062
D1	—	—	—	—
E1	—	—	—	—
k	—		—	
b	0.174	0.326	0.007	0.013
e	0.500TYP		0.020TRP.	
L	—	—	—	—
d	0.174	0.326	0.007	0.013

PHYSICAL DIMENSIONS (Cont'd)

SOP-8 PACKAGE OUTLINE DIMENSIONS

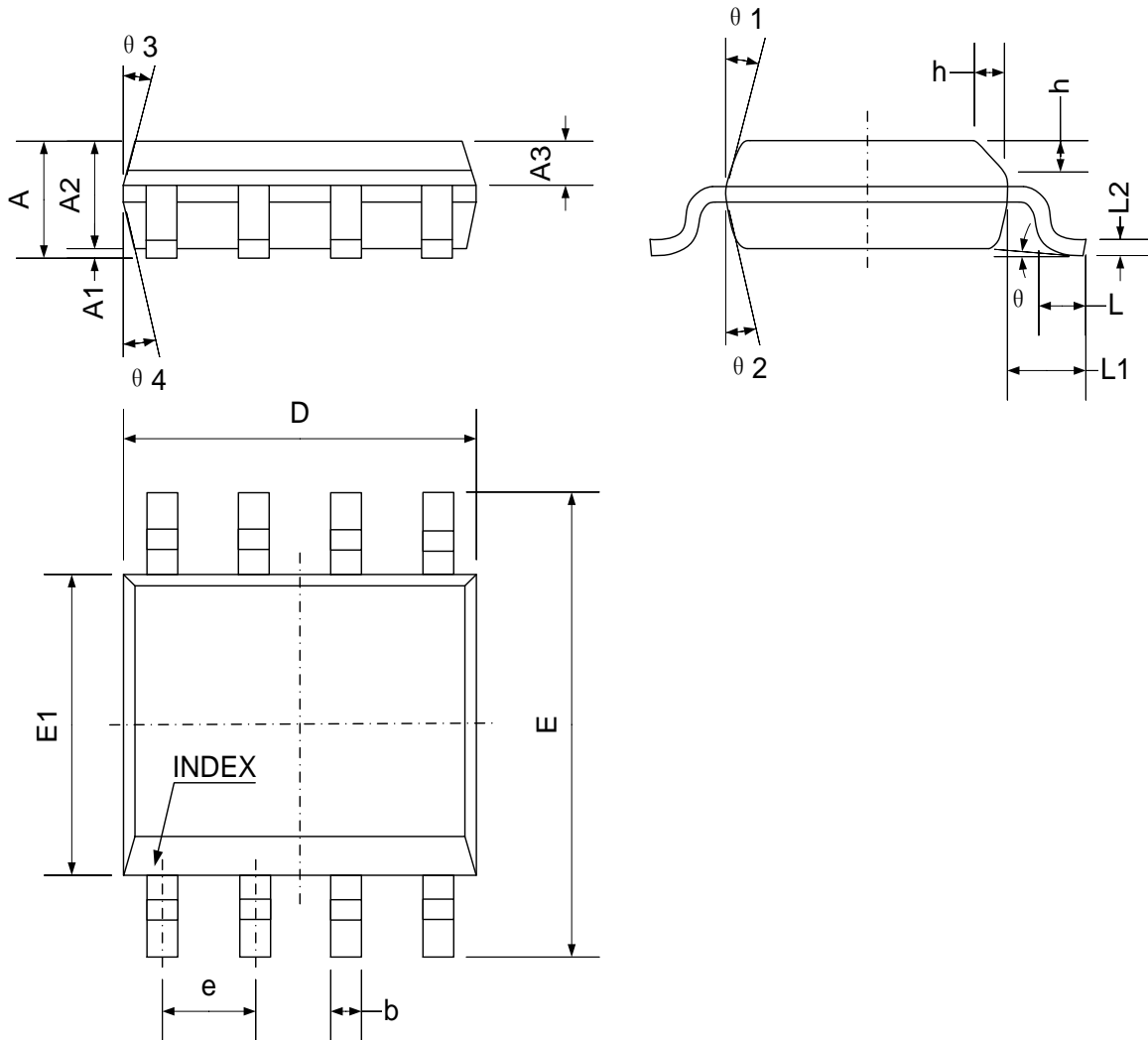

SYMBOL	MIN	NOM	MAX	UNIT
A	1.35	1.55	1.75	mm
A1	0.10	0.15	0.25	mm
A2	1.25	1.40	1.65	mm
A3	0.50	0.60	0.70	mm
b	0.38	-	0.51	mm
c	0.17	-	0.25	mm
D	4.80	4.90	5.00	mm
E	5.80	6.00	6.20	mm
E1	3.80	3.90	4.00	mm
e	1.27 (BSC)			mm
L	0.45	0.60	0.80	mm
L1	1.04REF			mm
L2	0.25BSC			mm
h	0.30	0.40	0.50	mm
θ	0	-	8°	
θ1	15°	17°	19°	
θ2	11°	13°	15°	
θ3	15°	17°	19°	
θ4	11°	13°	15°	

PHYSICAL DIMENSIONS (Cont'd)

MSOP-8 PACKAGE OUTLINE DIMENSIONS

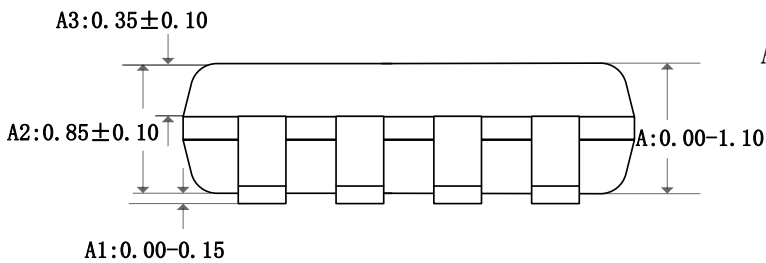
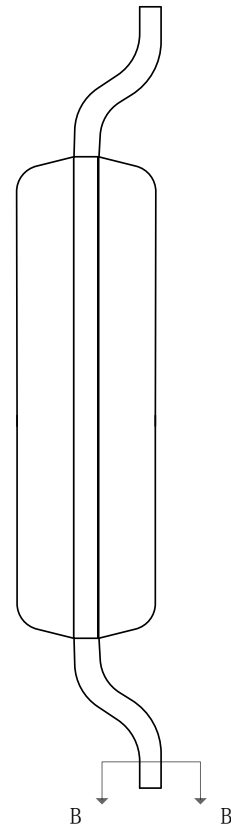
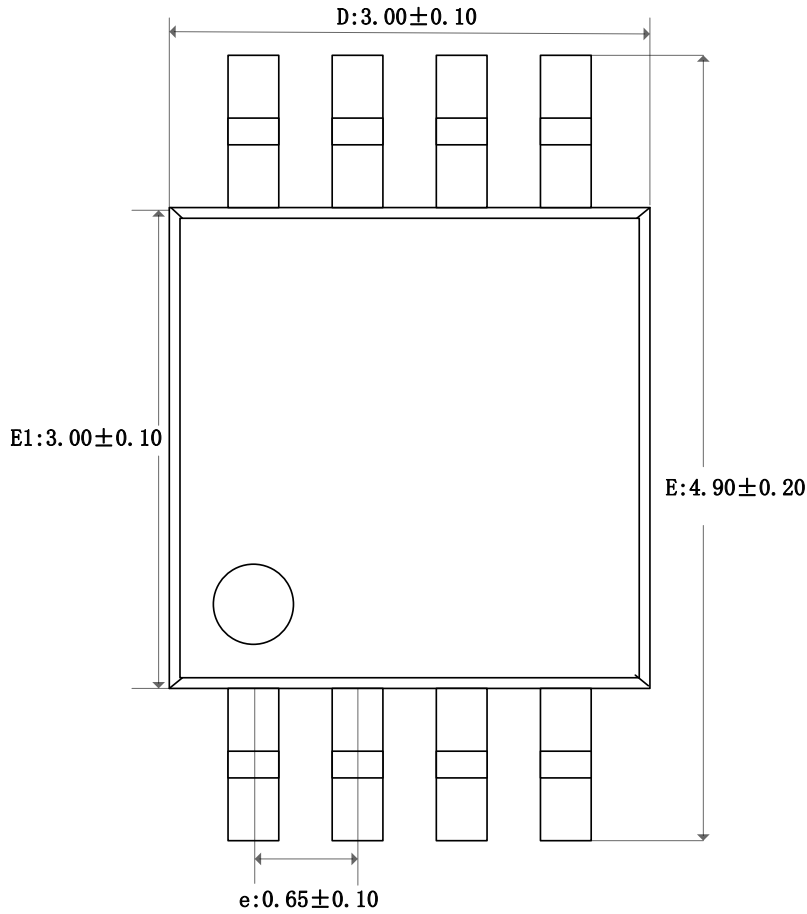

All dimensions are in millimeters

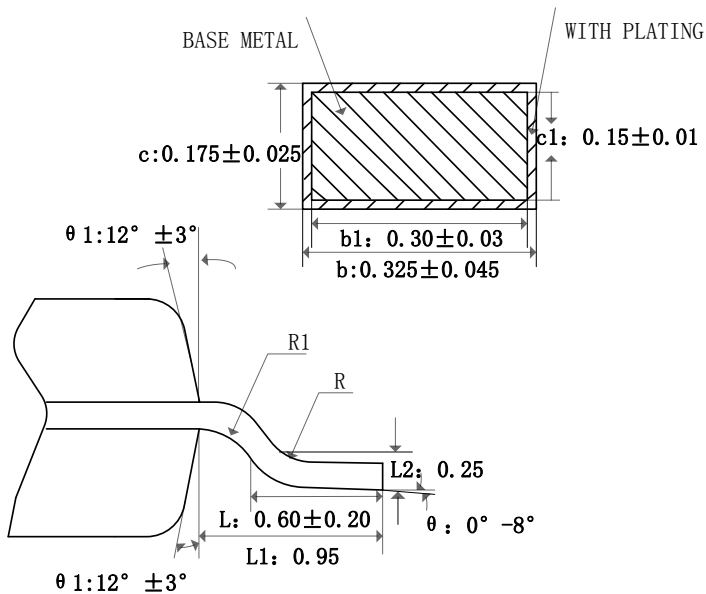

Symbol	Dimensions in Millimeters	
	Min.	Max.
A	—	1.10
A1	0	0.15
A2	0.75	0.95
A3	0.25	0.39
b	0.28	0.37
b1	0.27	0.33
c	0.15	0.20
c1	0.14	0.16
D	2.90	3.10
E	4.70	5.10
E1	2.90	3.10
e	0.55	0.75
L	0.40	0.80
L1	0.95REF.	
L2	0.25BSC.	
R	0.07	—
R1	0.07	—
θ	0°	8°
$\theta 1$	9°	15°

PHYSICAL DIMENSIONS (Cont'd)

DFN2X2-8L PACKAGE OUTLINE DIMENSIONS

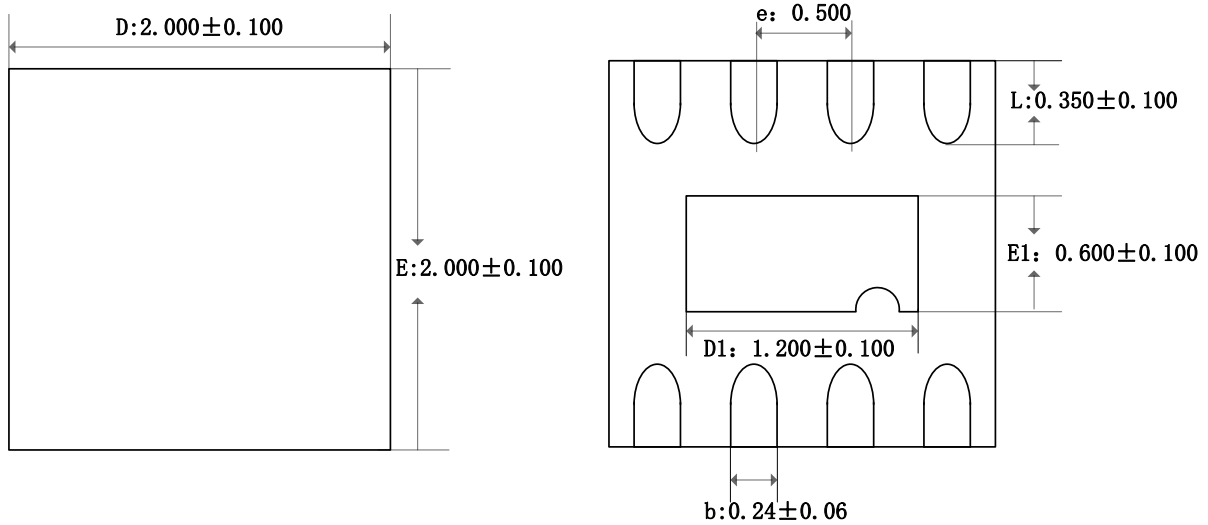

Top View

Bottom View

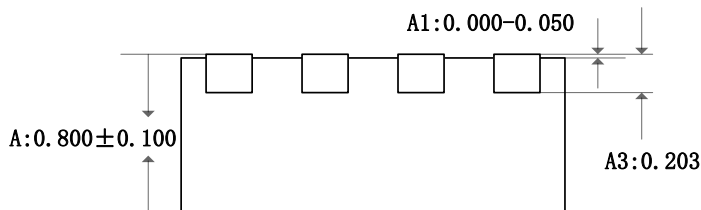

Side View

All dimensions are in millimeters

Symbol	Dimensions in Millimeters		Dimensions in Inches	
	Min.	Max.	Min.	Max.
A	0.700/0.800	0.800/0.900	0.028/0.031	0.031/0.035
A1	0.000	0.050	0.000	0.002
A3	0.203REF		0.008REF	
D	1.900	2.100	0.075	0.083
E	1.900	2.100	0.075	0.083
D1	1.100	1.300	0.043	0.051
E1	0.500	0.700	0.020	0.028
k	0.200MIN.		0.008MIN.	
b	0.180	0.300	0.007	0.012
e	0.500TYP		0.020TYP.	
L	0.250	0.450	0.010	0.018

IMPORTANT NOTICE

1. Disclaimer: The information in document is intended to help you evaluate this product. Fangtek, LTD. makes no warranty, either expressed or implied, as to the product information herein listed, and reserves the right to change or discontinue work on this product without notice.

2. Life support policy: Fangtek's products are not authorized for use as critical components in life support devices or systems without the express written approval of the president and general counsel of Fangtek Inc. As used herein

Life support devices or systems are devices or systems which, (a) are intended for surgical implant into the body, or (b) support or sustain life, and whose failure to perform when properly used in accordance with instructions for use provided in the labeling, can be reasonably expected to result in a significant injury to the user.

A critical component is any component of a life support device or system whose failure to perform can be reasonably expected to cause the failure of the life support device or system, or to affect its safety or effectiveness.

3. Fangtek assumes no liability for incidental, consequential or special damages or injury that may result from misapplications or improper use or operation of its products

4. Fangtek makes no warranty or representation that its products are subject to intellectual property license from Fangtek or any third party, and Fangtek makes no warranty or representation of non-infringement with respect to its products. Fangtek specifically excludes any liability to the customer or any third party arising from or related to the products' infringement of any third party's intellectual property rights, including patents, copyright, trademark or trade secret rights of any third party.

5. The information in this document is merely to indicate the characteristics and performance of Fangtek products. Fangtek assumes no responsibility for any intellectual property claims or other problems that may result from applications based on the document presented herein. Fangtek makes no warranty with respect to its products, express or implied, including, but not limited to the warranties of merchantability, fitness for a particular use and title.

6. Trademarks: The company and product names in this document may be the trademarks or registered trademarks of their respective manufacturers. Fangtek is trademark of Fangtek, LTD.

CONTACT INFORMATION

Fangtek Electronics (Shanghai) Co., Ltd

Room 503 & 504, Lane 198, Zhangheng Road
Zhangjiang Hi-tech Park, Pudong District
Shanghai, China, 201204

Tel: +86-21-61631978

Fax: +86-21-61631981

Website: www.fangtek.com.cn