

② CODING B,C
 2322347-2 AS SHOWN

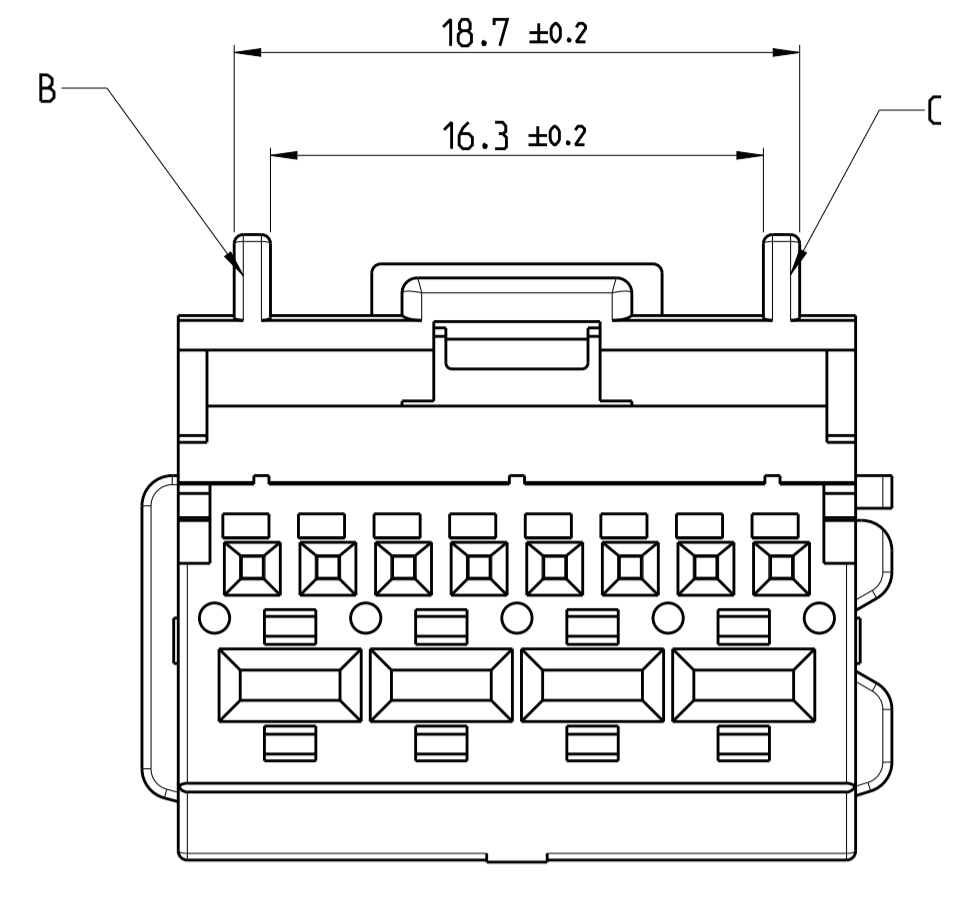

① CODING A,D
 2322347-1 AS SHOWN

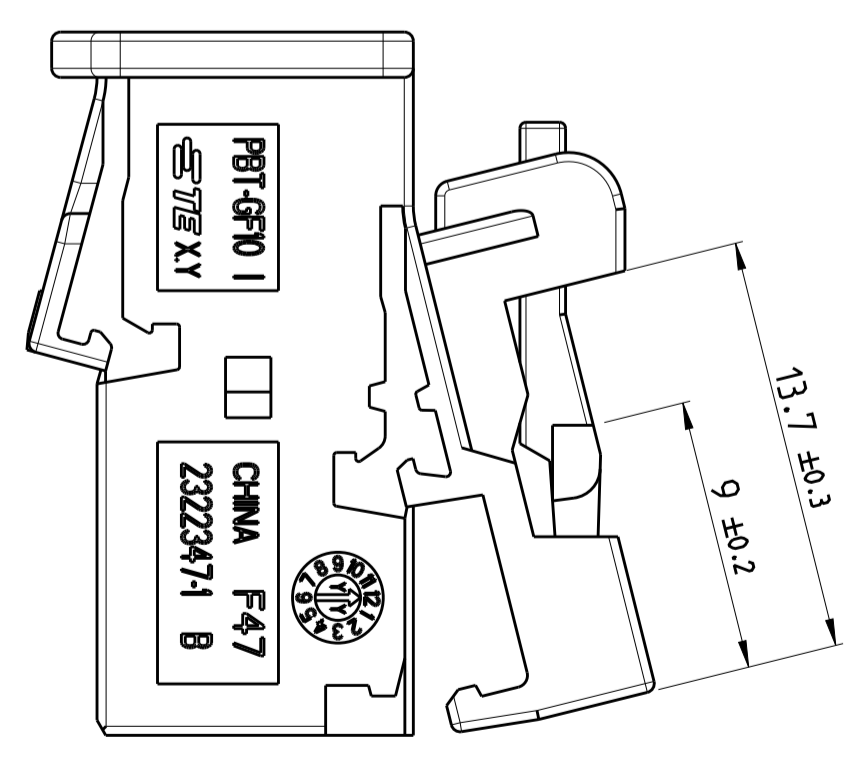
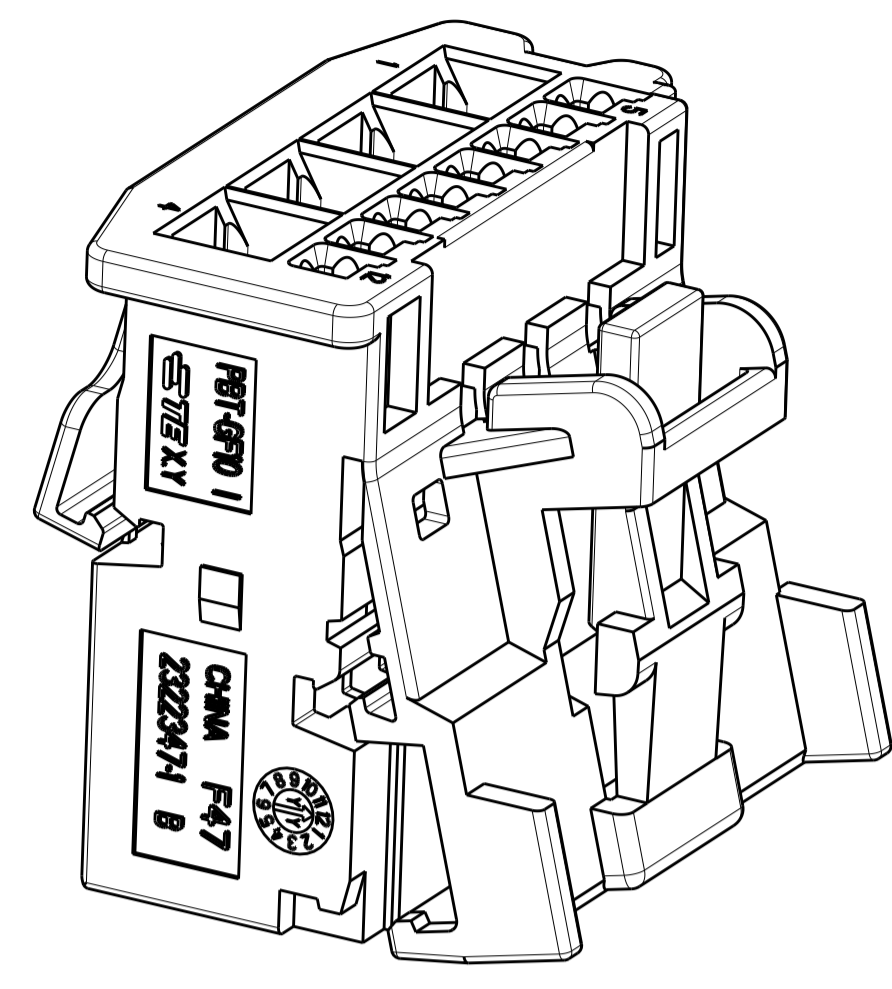
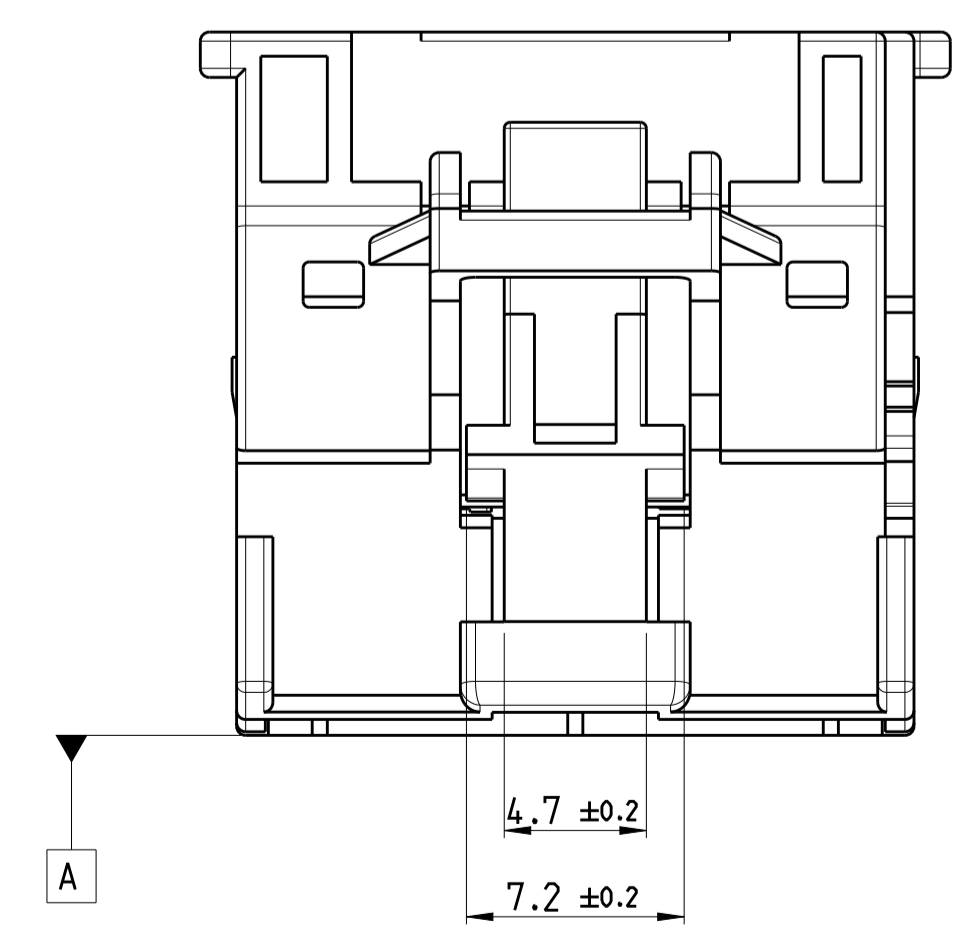
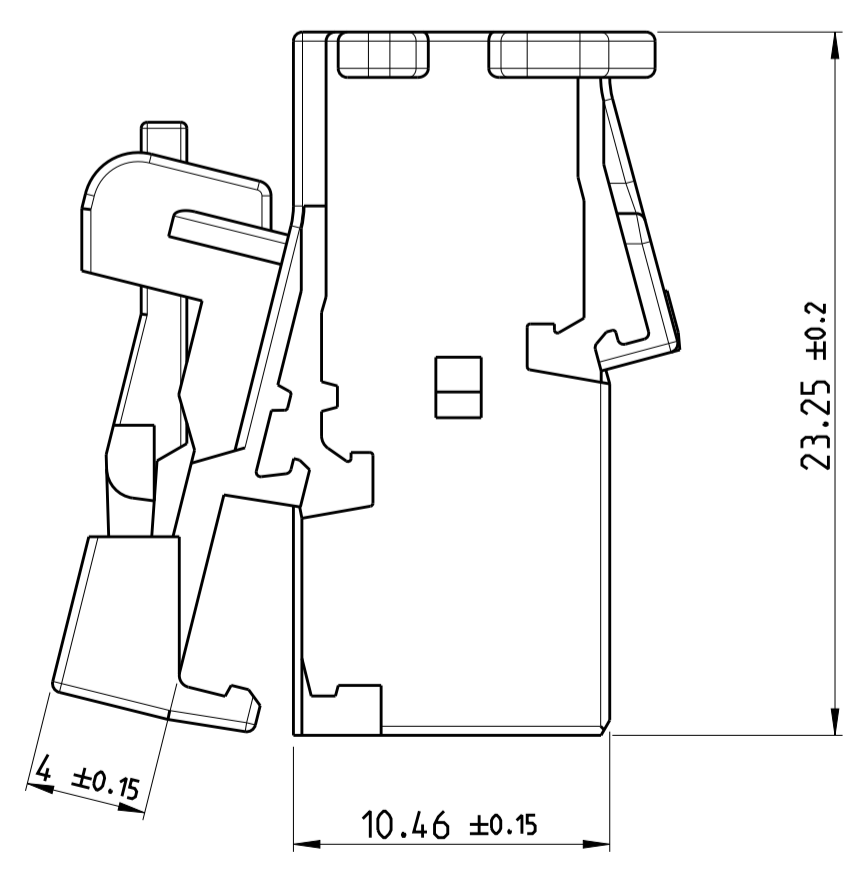
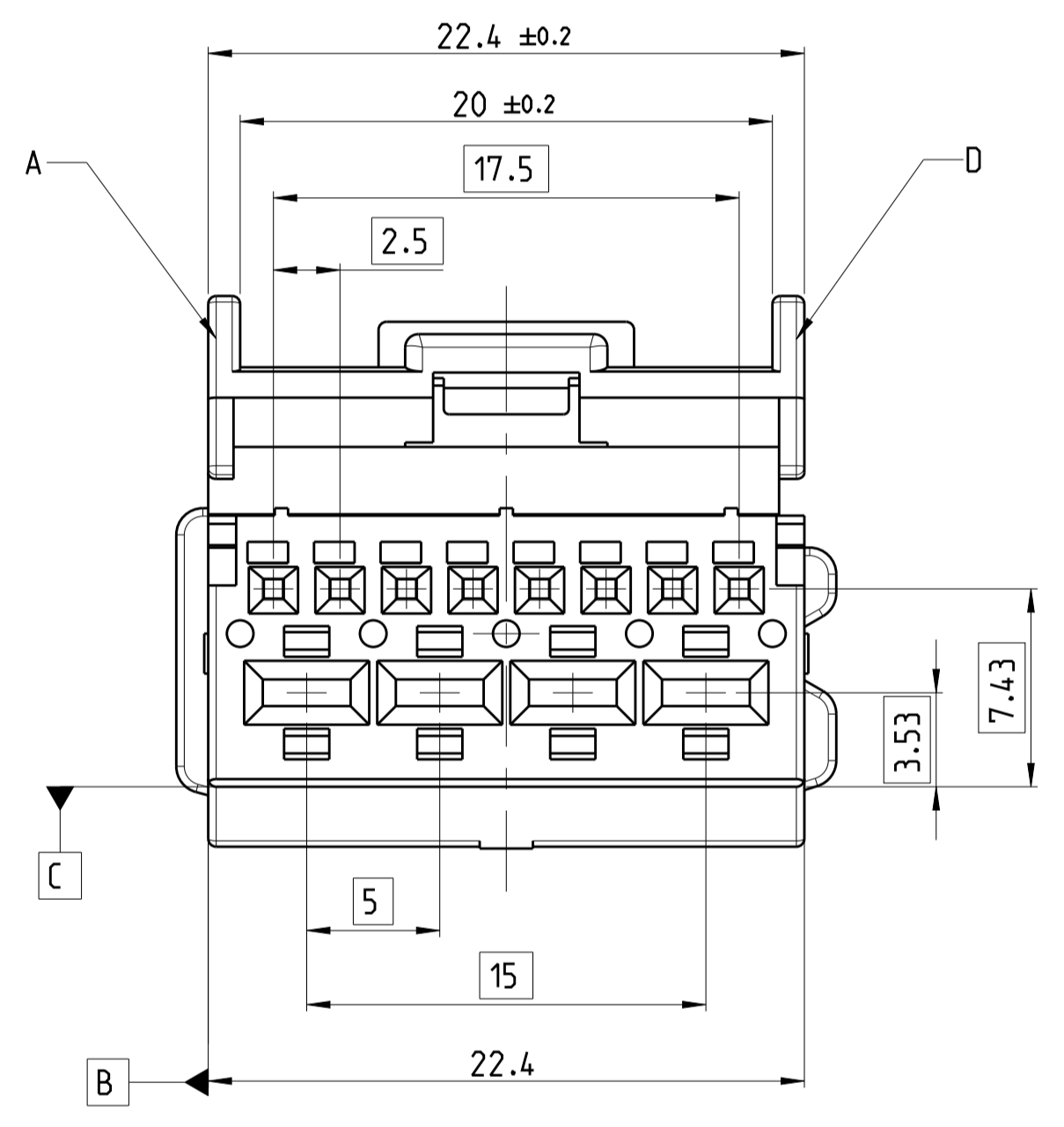

REVISIONS				
P	LTR	DESCRIPTION	DATE	DWN APVD
A		NEW PRODUCT RELEASED	31AUG2017	T.D I.Y
B		ECR-19-004905	13JUN2019	J.L I.Y

RETAINER CLOSED PICTURE

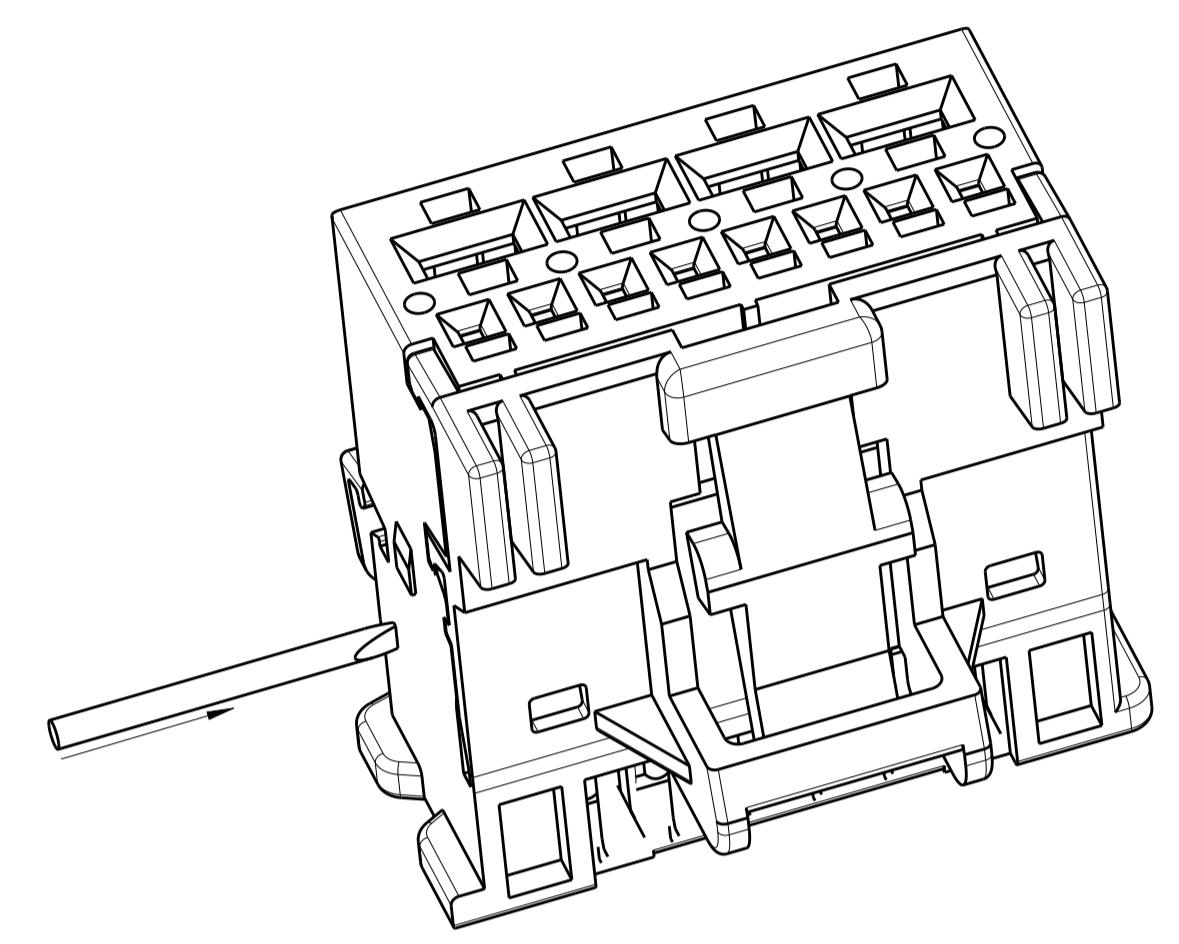

⑥ OPEN GUIDE:
 TO OPEN THE LOCKED RETAINER, USE A Ø 1X0.18MM SCREWDRIVER AND PUSH IT IN THE SHOWN OPENING.

NOTES

- 1 MATING PART EXECUTION TO INTERFACE 114-101068
- 2 SUITABLE CONTACT
 MQS: 1355717, 928999, 963715
 MCP2.8K: 1241386, 1241388, 1241390
- 3 SUITABLE MATING HOUSING 2311788/2321709
- 4 MATERIAL REMOVAL OPTIONAL IN EXECUTION AND POSITION ACC. TO MANUFACTURE POSSIBLE
- 5 PACKAGE: LOOSE PIECE IN CARTON BOX
- ⑥ ⑥ CONDITION ON DELIVERY:
 SECONDARY LOCK DEVICE SHOULD BE IN PRELOCK POSITION
 --IF IN ENDOCK POSITION AFTER TRANSPORTATION,
 PLEASE REOPEN IT IN ACCORDANCE THE OPENING GUIDE

TE-PART NO	REV.	COD.	MATERIAL	COLOUR	RAL	VOLUME [cm ³]	WEIGHT [g]	POS.
2322347-4	B	B.D	PBT-GF10	BLUE	5012	1.976	2.71	4
2322347-3	B	A.C	PBT-GF10	GREEN	6018	1.976	2.71	3
2322347-2	B	B.C	PBT-GF10	BROWN	1011	1.976	2.71	2
2322347-1	B	A.D	PBT-GF10	BLACK	9011	1.976	2.71	1

THIS DRAWING IS A CONTROLLED DOCUMENT.		DWN T.DONG 16AUG2017	
DIMENSIONS: mm		CHE E.JIANG 31AUG2017	
TOLERANCES UNLESS OTHERWISE SPECIFIED		APVD L.YIN 31AUG2017	NAME
0 PLC ± 1 PLC ± 2 PLC ± 3 PLC ± 4 PLC ± 5 BCC ± DIMENSIONAL FINISHES ±0.2*		PRODUCT SPEC 108-101599	HYBRID MQS 8POS./MCP2.8K 4POS.. REC.. HSG.
MATERIAL SEE TABLE		WEIGHT -	SIZE CAGE CODE DRAWING NO RESTRICTED TO
SEE TABLE		CUSTOMER DRAWING	A 1 00779 C=2322347
		SCALE 4:1	SHEET 1 OF 1 REV B