

# Automotive High-Efficiency Single 16A/22A/30A/40A Step-Down Converter Family

MAX20411

## General Description

The MAX20411 is a family of high-efficiency, synchronous step-down converters that operate with a 3.0V to 5.5V input voltage range and supply a 0.5V to 1.275V output voltage range. The wide input/output voltage range and the ability to provide up to 40A peak output current make this device family ideal for on-board point-of-load and post-regulation applications. The MAX20411 achieves as low as  $\pm 0.75\%$  output error over load, line, and temperature ranges.

The MAX20411 features a 2.1MHz fixed-frequency PWM mode for better noise immunity and load-transient response. The 2.1MHz frequency operation allows for the use of all ceramic capacitors and minimizes external components. The spread-spectrum frequency modulation option minimizes radiated electromagnetic emissions. Integrated low  $R_{DS(ON)}$  switches improve efficiency at heavy loads and make layout simpler than discrete solutions.

This device features the MAXQ<sup>®</sup> power architecture, which provides precision transient performance and phase margin. This allows obtaining the maximum power, performance, and precision while minimizing system cost for any specific application.

The MAX20411 is offered with a factory-preset output voltage. (See the [Ordering Information](#) table for options.) The I<sup>2</sup>C interface supports dynamic voltage adjustment with programmable slew rates. Other features include programmable soft-start and overtemperature protections.

## Applications

- Automotive ADAS Systems
- SoC Core Power

MAXQ is a registered trademark of Maxim Integrated Products, Inc.

## Benefits and Features

- High-Efficiency DC-DC Converter
- Up to 40A Peak Output Current
  - MAX20411A: 16A
  - MAX20411B: 22A
  - MAX20411C: 30A
  - MAX20411D: 40A
- Differential Remote Voltage Sensing
- 3.0V to 5.5V Operating Supply Voltage
- I<sup>2</sup>C-Controlled Output Voltage
  - 0.5V to 1.275V in 6.25mV Steps
- Excellent Load-Transient Performance
- Advanced Programmable Compensation
  - MAXQ Power Architecture
  - Hybrid Load Line and Integrator Options
- 2.1MHz or 1.05MHz Operation
- As Low as  $\pm 0.75\%$  Output Voltage Accuracy
- RESET Output
- Current-Mode, Forced-PWM Operation
- ASIL D Compliant
  - Redundant Reference
  - BIST Diagnostics
  - PEC on I<sup>2</sup>C
  - Programmable OV/UV with  $\pm 1\%$  Accuracy
- Overtemperature and Short-Circuit Protection
- 3.5mm x 5mm, 21-Pin, Side-Wettable FCQFN
- AEC-Q100 Qualified
- -40°C to +125°C Grade 1 Temperature Range

## Simplified Block Diagram

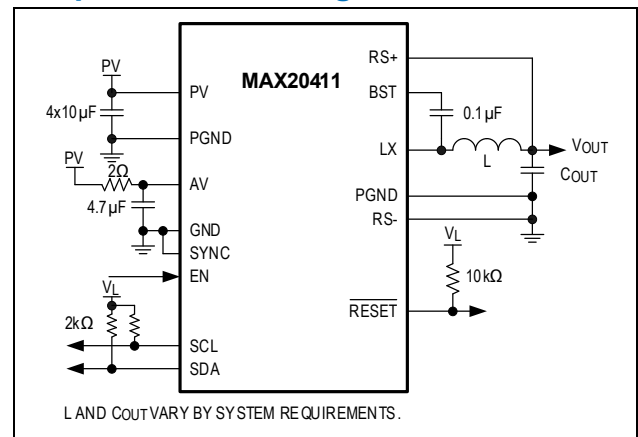

[Ordering Information](#) appears at end of data sheet.

Visit [Web Support](#) to complete the nondisclosure agreement (NDA) required to receive additional product information.

