



180-052
2 Channel Fiber Optic Receptacle Connector
for M29504/05 Socket Terminus

D38999
Series III

B

2 Channel fiber optic receptacle connector



How To Order

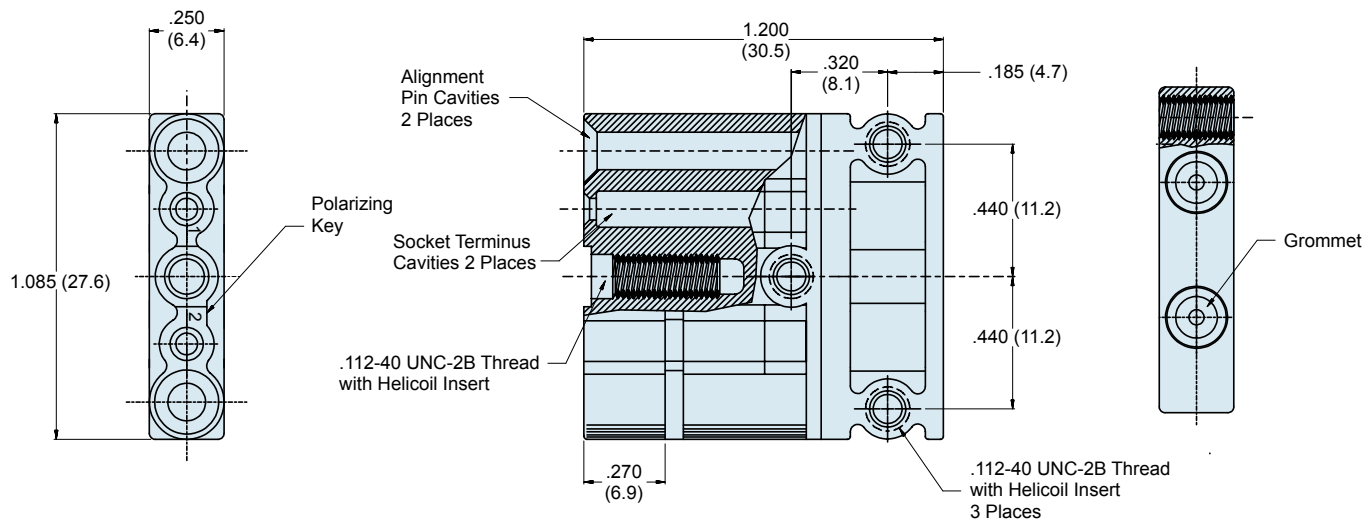
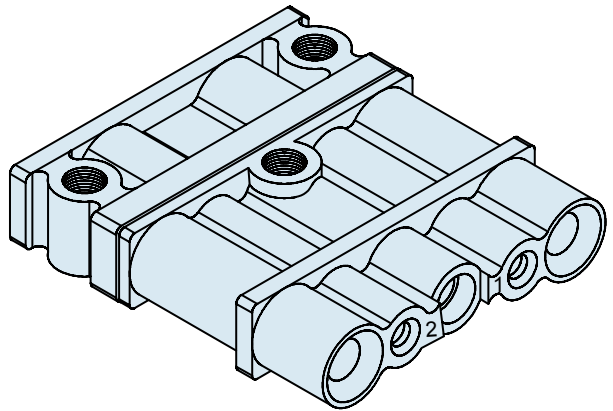
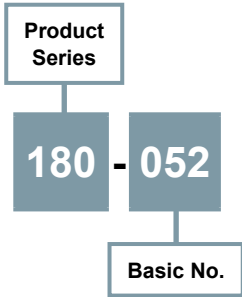

Material and Finish

Connector Housing: High Grade Engineering Thermoplastic
Grommet: Fluorosilicone
Helicoil Insert: Stainless Steel

Notes

Connector designed to accept Glenair Part Number 181-001 or MIL-PRF-29504/5 Style Fiber Optic Termini. Termini not supplied.
Recommended Insertion/Removal Tool: P/N M81969/14-03 or equivalent.

Mouser Electronics

Authorized Distributor

Click to View Pricing, Inventory, Delivery & Lifecycle Information:

[Glenair:](#)

[180-052](#)