

Feature

- 100W peak pulse power per line ($t_p = 8/20\mu S$)
- SOT-563 package
- Protects four bidirectional lines and five Unidirectional lines
- Monolithic structure
- Working voltage: 5V
- Low clamping voltage
- ESD protection > 40 KV
- Low leakage current
- RoHS compliant
- Transient protection for data lines to IEC 61000-4-2(ESD) $\pm 15KV(\text{air})$, $\pm 8KV(\text{contact})$; IEC 61000-4-4 (EFT) 40A (5/50ns)

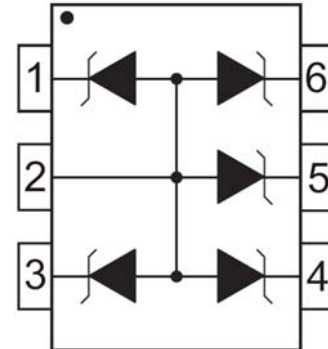

Applications

- Communication systems & Cellular phones
- Printers
- Notebook and hand hold computers
- PDAs
- Video Equipment

Electrical characteristics per line@25°C(unless otherwise specified) note1

Parameter	Symbol	Conditions	Min.	Typ.	Max.	Units
Reverse stand-off voltage	V_{RWM}				5	V
Reverse Breakdown voltage	V_{BR}	$I_t = 1mA$	6			V
Reverse Leakage Current	I_R	$V_{RWM} = 5V T=25^\circ C$			5	μA
Clamping Voltage	V_C	$I_{PP} = 1A t_p = 8/20\mu S$			8.8	V
Clamping Voltage	V_C	$I_{PP}=10A t_p = 8/20\mu S$			10.0	V
Junction Capacitance	C_j	$V_R=0V f = 1MHz$		40		pF

Absolute maximum rating @25°C note1

Rating	Symbol	Value	Units
Peak Pulse Power ($t_p=8/20\mu S$)	P_{pp}	100	W
Forward voltage@10mA	V_F	1.5	V
Operating Temperature	T_J	-55 to +150	$^\circ C$
Storage Temperature	T_{STG}	-55 to +150	$^\circ C$

- Note1: Pin 1, 3, 4, 5 or 6 to Pin 2

Typical Characteristics

FIGURE 1
PEAK PULSE POWER VS PULSE TIME

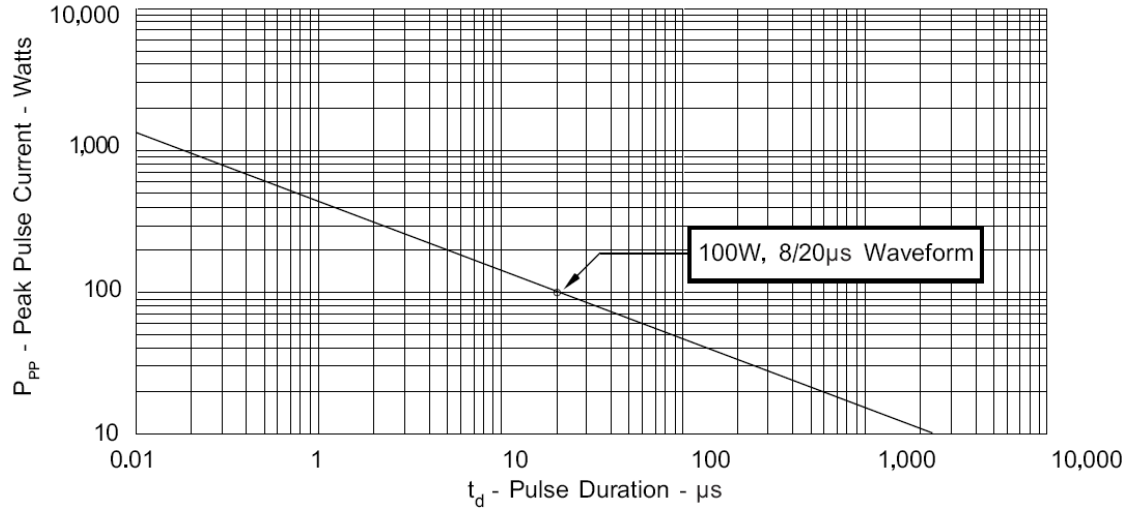

FIGURE 2
PULSE WAVE FORM

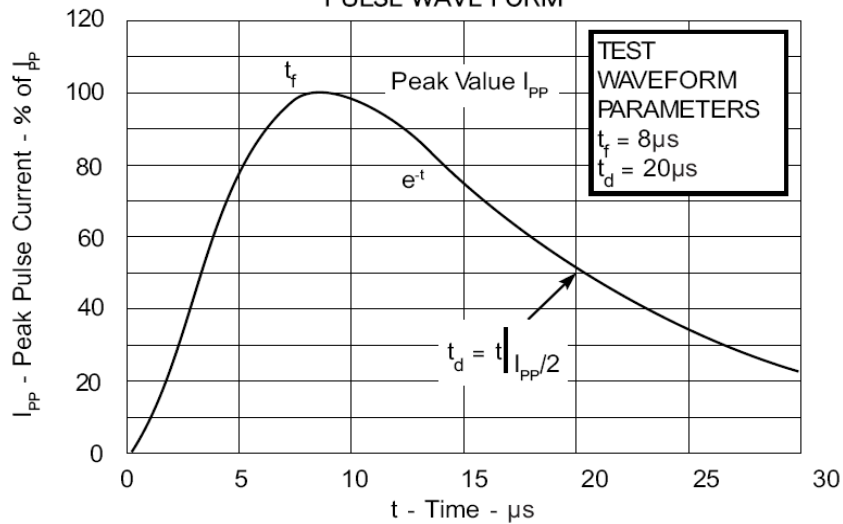
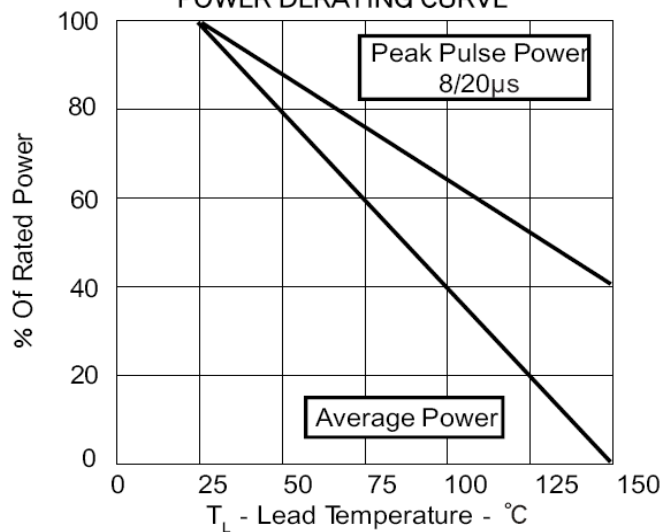

FIGURE 3
POWER DERATING CURVE



Typical Characteristics

FIGURE 4
OVERSHOOT & CLAMPING VOLTAGE FOR

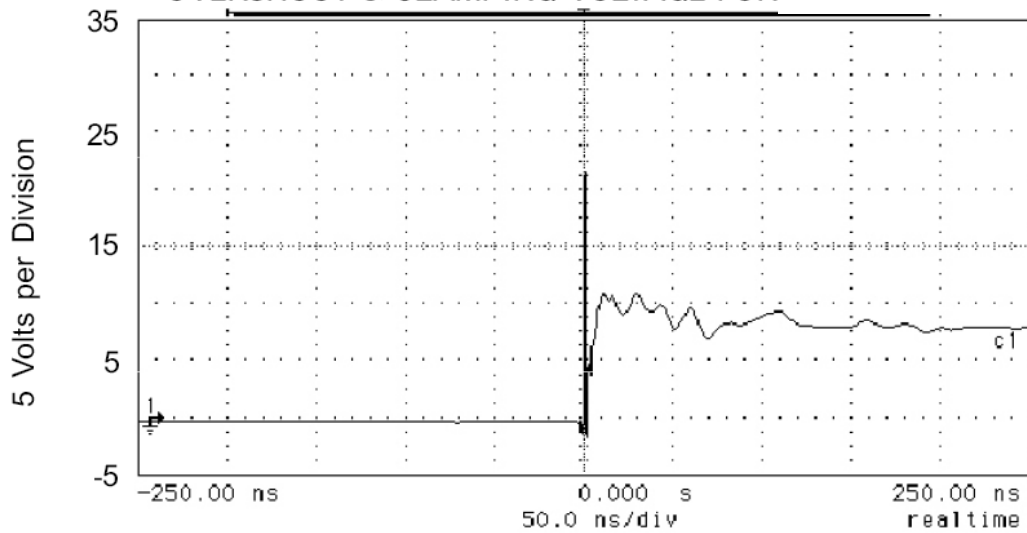

FIGURE 5
TYPICAL CLAMPING VOLTAGE VS PEAK PULSE CURRENT F

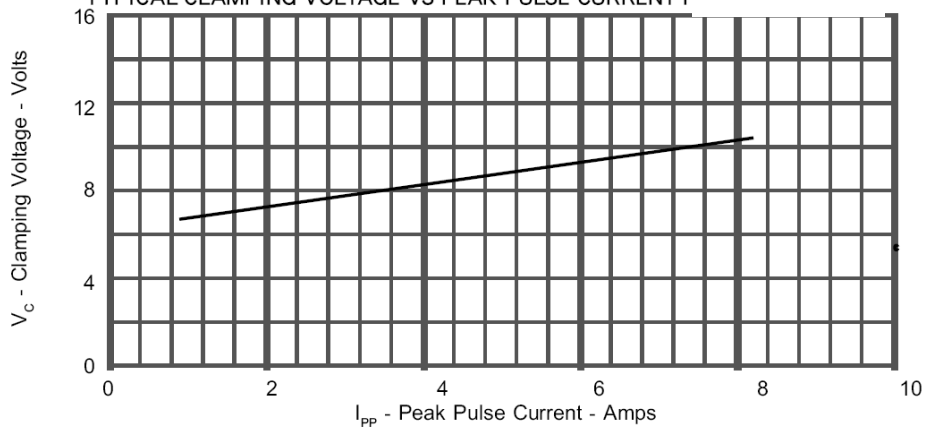
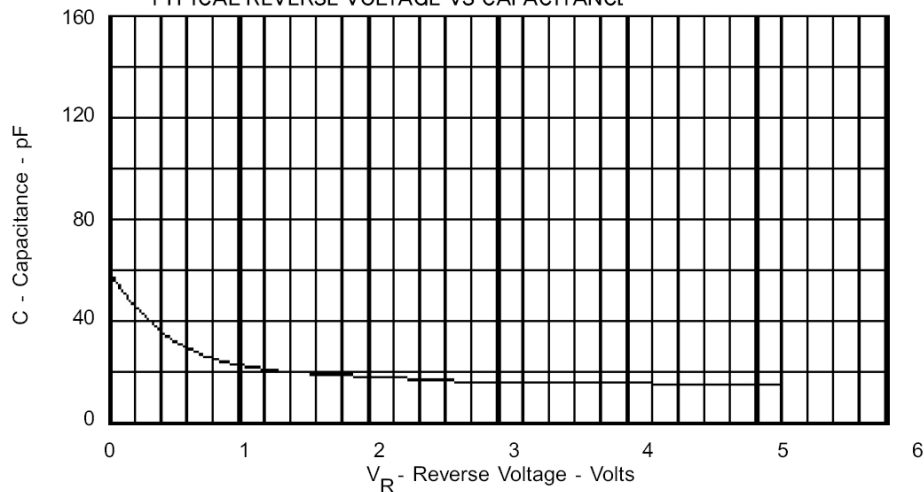
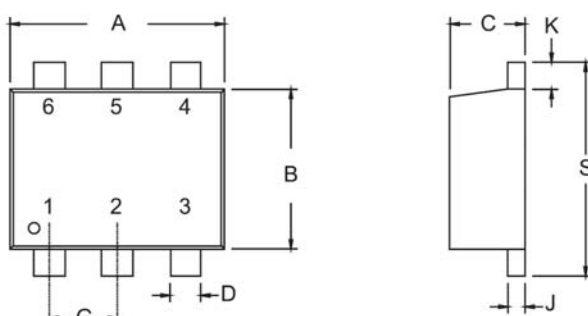

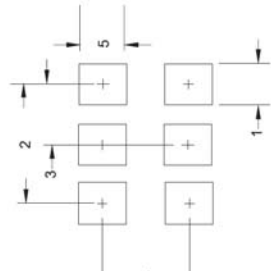

FIGURE 6
TYPICAL REVERSE VOLTAGE VS CAPACITANCE



Product dimension and pad size

<p style="text-align: center;">PACKAGE OUTLINE</p> 	<p style="text-align: center;">SOT-563</p>  <p style="text-align: center;">PACKAGE DIMENSIONS</p> <table border="1" style="width: 100%; border-collapse: collapse; text-align: center;"> <thead> <tr> <th rowspan="2">DIM</th> <th colspan="2">MILLIMETERS</th> <th colspan="2">INCHES</th> </tr> <tr> <th>MIN</th> <th>MAX</th> <th>MIN</th> <th>MAX</th> </tr> </thead> <tbody> <tr> <td>A</td> <td>1.50</td> <td>1.70</td> <td>0.059</td> <td>0.067</td> </tr> <tr> <td>B</td> <td>1.10</td> <td>1.30</td> <td>0.043</td> <td>0.051</td> </tr> <tr> <td>C</td> <td>0.50</td> <td>0.60</td> <td>0.020</td> <td>0.024</td> </tr> <tr> <td>D</td> <td>0.17</td> <td>0.27</td> <td>0.007</td> <td>0.011</td> </tr> <tr> <td>G</td> <td>0.50 BSC</td> <td>-</td> <td>0.020 BSC</td> <td>-</td> </tr> <tr> <td>J</td> <td>0.08</td> <td>0.16</td> <td>0.003</td> <td>0.006</td> </tr> <tr> <td>K</td> <td>0.10</td> <td>0.30</td> <td>0.004</td> <td>0.012</td> </tr> <tr> <td>S</td> <td>1.50</td> <td>1.70</td> <td>0.059</td> <td>0.067</td> </tr> </tbody> </table>	DIM	MILLIMETERS		INCHES		MIN	MAX	MIN	MAX	A	1.50	1.70	0.059	0.067	B	1.10	1.30	0.043	0.051	C	0.50	0.60	0.020	0.024	D	0.17	0.27	0.007	0.011	G	0.50 BSC	-	0.020 BSC	-	J	0.08	0.16	0.003	0.006	K	0.10	0.30	0.004	0.012	S	1.50	1.70	0.059	0.067
DIM	MILLIMETERS		INCHES																																															
	MIN	MAX	MIN	MAX																																														
A	1.50	1.70	0.059	0.067																																														
B	1.10	1.30	0.043	0.051																																														
C	0.50	0.60	0.020	0.024																																														
D	0.17	0.27	0.007	0.011																																														
G	0.50 BSC	-	0.020 BSC	-																																														
J	0.08	0.16	0.003	0.006																																														
K	0.10	0.30	0.004	0.012																																														
S	1.50	1.70	0.059	0.067																																														
<p style="text-align: center;">MOUNTING PAD</p> <table border="1" style="width: 100%; border-collapse: collapse; text-align: center; margin-bottom: 10px;"> <thead> <tr> <th colspan="3">TYPICAL</th> </tr> <tr> <th>DIM</th> <th>Millimeters</th> <th>Inches</th> </tr> </thead> <tbody> <tr> <td>1</td> <td>0.30</td> <td>0.012</td> </tr> <tr> <td>2</td> <td>1.02</td> <td>0.040</td> </tr> <tr> <td>3</td> <td>0.51</td> <td>0.020</td> </tr> <tr> <td>4</td> <td>1.40</td> <td>0.055</td> </tr> <tr> <td>5</td> <td>0.51</td> <td>0.020</td> </tr> </tbody> </table> 	TYPICAL			DIM	Millimeters	Inches	1	0.30	0.012	2	1.02	0.040	3	0.51	0.020	4	1.40	0.055	5	0.51	0.020	<p>NOTES</p> <ol style="list-style-type: none"> 1. Dimensioning and tolerances per ANSI Y14.5M, 1985. 2. Controlling Dimension: Inches 3. Pin 3 is the cathode (Unidirectional Only). 4. Dimensions are exclusive of mold flash and metal burrs. <p>TAPE & REEL/BULK ORDERING NOMENCLATURE</p> <ol style="list-style-type: none"> 1. Surface mount product is taped and reeled in accordance with EIA-481. 2. 7 Inch Reel - 3,000 pieces per 8mm tape. 																												
TYPICAL																																																		
DIM	Millimeters	Inches																																																
1	0.30	0.012																																																
2	1.02	0.040																																																
3	0.51	0.020																																																
4	1.40	0.055																																																
5	0.51	0.020																																																

Tape & Reel Specifications (Dimensions in millimeters)

Reel Dia.	Tape Width	A0	B0	K0	D	E	F	W	P0	P2	P	tmax
178mm (7")	8mm	1.78 ± 0.05	1.78 ± 0.05	0.69 ± 0.05	1.50 ± 0.10	1.75 ± 0.10	3.50 ± 0.05	8.00 ± 0.30	4.00 ± 0.10	2.00 ± 0.05	4.00 ± 0.10	0.25

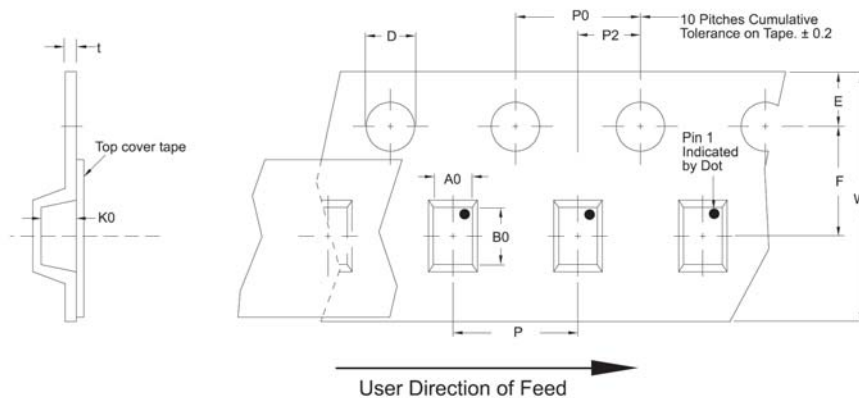

Application note

The **SES5VT563-6** Series is TVS arrays designed to protect I/O or data lines from the damaging effects of ESD or EFT. This product provides both unidirectional and bidirectional protection, with a surge capability of 100 Watts Ppp per line for an 8/20 μ s wave shape and ESD protection > 25 kilovolts.

COMMON-MODE UNIDIRECTIONAL CONFIGURATION (Figure 1)

The **SES5VT563-6** Series provides up to 5 lines of protection in a common-mode unidirectional configuration as depicted in Figure 1.

Circuit connectivity is as follows:

- Line 1 is connected to Pin 1.
- Line 2 is connected to Pin 3.
- Line 3 is connected to Pin 4.
- Line 4 is connected to Pin 6.
- Line 5 is connected to Pin 5.
- Pin 2 is connected to ground.

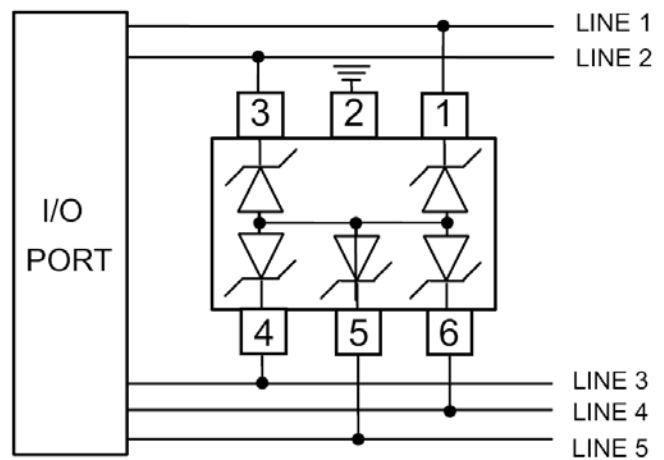

(Figure 1)

COMMON-MODE BIDIRECTIONAL CONFIGURATION (Figure 2)

The **SES5VT563-6** Series provides up to 4 lines of protection in a common-mode bidirectional configuration as depicted in Figure 2.

Circuit connectivity is as follows:

- Line 1 is connected to Pin 1.
- Line 2 is connected to Pin 3.
- Line 3 is connected to Pin 4.
- Line 4 is connected to Pin 6.
- Pin 2 is not connected.
- Pin 5 is connected to ground.

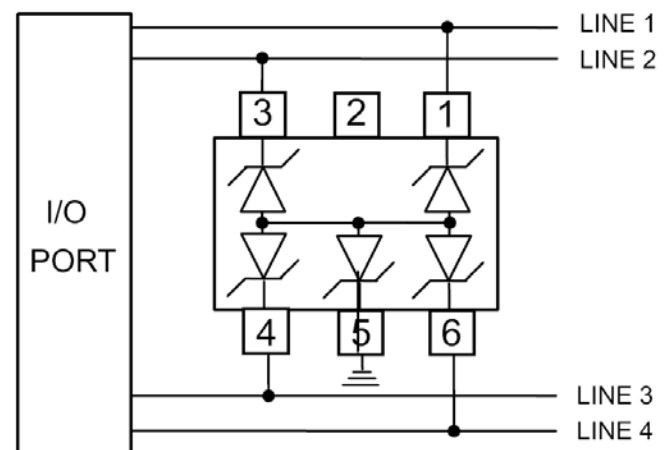

(Figure 2)

Application note

DIFFERENTIAL-MODE BIDIRECTIONAL CONFIGURATION (Figure 3)

The **SES5VT563-6** Series provides up to 5 lines of protection in a differential-mode bidirectional configuration as depicted in Figure 3.

Circuit connectivity is as follows:

- Line 1 is connected to Pin 1.
- Line 2 is connected to Pin 3.
- Line 3 is connected to Pin 4.
- Line 4 is connected to Pin 6.
- Line 5 is connected to Pin 5.
- Pin 2 is not connected.

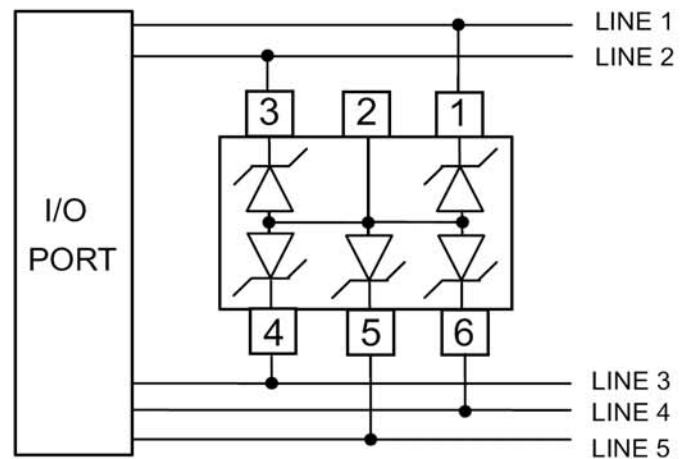

(Figure 3)

Circuit board layout and protection device placement:

Circuit board layout is critical for the suppression of ESD transients.

The following guidelines are recommended:

1. Place the protection device as close to the input terminal or connector as possible.
2. The path length between the protection device and the protected line should be minimized.
3. Keep parallel signal paths to a minimum.
4. Avoid running protection conductors in parallel with unprotected conductor.
5. Minimize all printed-circuit board conductive loops including power and ground loops.
6. Minimize the length of the transient return path to ground.
7. Avoid using shared transient return paths to a common ground point.
8. Ground planes should be used whenever possible. For multilayer printed-circuit boards, use ground vias.

Revision History

Revision	Date	Changes
1.0	2008-7-3	-

Website: <http://www.semiteltech.com>

For additional information, please contact your local Sales Representative.

©Copyright 2005, Semitel Electronics

 **Semitel**® is a registered trademark of Semitel Electronics.

All rights reserved.