

# SPECIFICATION CONTROL DRAWING

**CMC-0547**

TITLE	WIRE, RADIATION-CROSSLINKED, MODIFIED FLEXIBLE ETFE-INSULATED, NORMAL WEIGHT, GENERAL PURPOSE, 600 VOLT	Date	10-7-08	Revision	H
-------	---	------	---------	----------	---

This specification sheet forms a part of the latest issue of Raychem Specification 80.

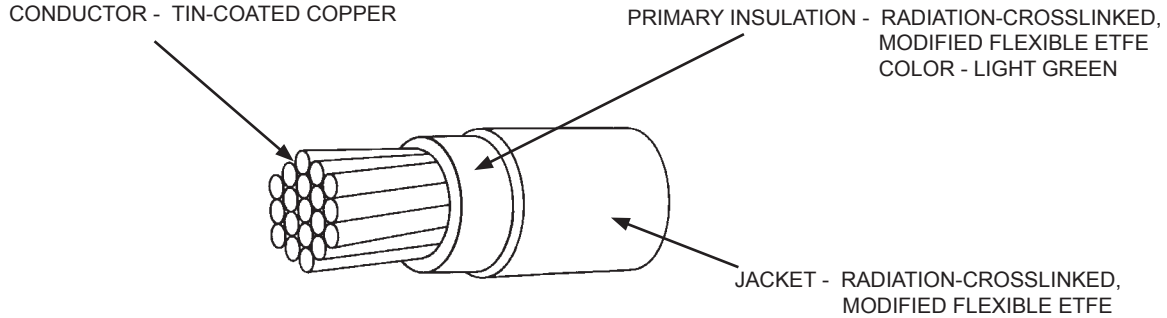

TABLE I. CONSTRUCTION DETAILS

PART NUMBER 1/	WIRE SIZE (AWG)	CONDUCTOR STRANDING (number x AWG)	DIAMETER OF STRANDED CONDUCTOR (in.)		FINISHED WIRE		
			MINIMUM	MAXIMUM	MAXIMUM RESISTANCE AT 20°C (ohms/1000 ft.)	DIAMETER (in.)	MAXIMUM WEIGHT (lbs/1000 ft.)
CMC-0547-10-*	10	37 x 26	.106	.113	1.26	.151 ± .006	37.3
CMC-0547-8-*	8	133 x 29	.158	.173	.701	.216 ± .008	67.8
CMC-0547-6-*	6	133 x 27	.198	.217	.445	.267 ± .010	106.
CMC-0547-4-*	4	133 x 25	.250	.274	.280	.325 ± .010	165.
CMC-0547-2-*	2	665 x 30	.320	.340	.183	.407 ± .016	255.
CMC-0547-1-*	1	817 x 30	.360	.380	.149	.453 ± .016	310.
CMC-0547-0-*	0	1045 x 30	.395	.425	.116	.504 ± .016	402.
CMC-0547-00-*	00	1330 x 30	.440	.475	.091	.553 ± .016	500.
CMC-0547-000-*	000	1665 x 30	.500	.540	.071	.630 ± .016	614.
CMC-0547-0000-*	0000	2109 x 30	.565	.605	.056	.698 ± .016	765.

TABLE II. PERFORMANCE DETAILS

PART NUMBER 1/	BEND TESTING	
	MANDREL DIAMETER (inch) (± 3%)	WEIGHT (lb) (± 3%)
	CROSSLINKING PROOF TEST	CROSSLINKING PROOF TEST
CMC-0547-10-*	2.00	3.00
CMC-0547-8-*	3.00	4.00
CMC-0547-6-*	4.00	4.00
CMC-0547-4-*	5.00	4.00
CMC-0547-2-*	6.00	6.00
CMC-0547-1-*	8.00	6.00
CMC-0547-0-*	8.00	6.00
CMC-0547-00-*	10.0	8.00
CMC-0547-000-*	10.0	8.00
CMC-0547-0000-*	10.0	8.00

Users should evaluate the suitability of this product for their application. Specifications are subject to change without notice. Tyco Electronics also reserves the right to make changes in materials or processing, which do not affect compliance with any specification, without notification to Buyer.

1/ COLORS AND COLOR CODE DESIGNATORS SHALL BE IN ACCORDANCE WITH MIL-STD-681. OTHER CODES AND SUFFIXES MAY BE ADDED TO THE PART NUMBER. AS NECESSARY, TO CAPTURE ANY ADDITIONAL REQUIREMENTS IMPOSED BY THE PURCHASE ORDER.

Page 1 of 2	The TE logo, Tyco Electronics and Raychem are trademarks.		Raychem Wire & Cable 501 Oaks Avenue Redwood City, CA 94063-3800 Phone: 1-800-227-8816 Fax: 1-650-361-6297
	DIMENSIONS ARE IN INCHES, AND UNLESS OTHERWISE DESIGNATED ARE NOMINAL.		
	THIS SPECIFICATION SHEET TAKES PRECEDENCE OVER DOCUMENTS REFERENCED HEREIN. REFERENCED DOCUMENTS SHALL BE OF THE ISSUE IN EFFECT ON DATE OF INVITATION FOR BID.		

## WIRE RATINGS AND ADDITIONAL REQUIREMENTS

## TEMPERATURE RATING: 150°C

Maximum continuous conductor temperature

VOLTAGE RATING: 600 volts (rms) at sea level

CONCENTRICITY: 70% (minimum)

CROSSLINKING PROOF TEST: 300 ± 3°C for 7 hours

IDENTIFICATION AND COLOR STRIPING DURABILITY:

125 cycles (250 strokes) (minimum), 500 g weight

INSULATION ELONGATION AND TENSILE STRENGTH:

AWG 10: Elongation, 75% (minimum)  
Tensile Strength, 3500 lbf/in<sup>2</sup> (minimum)

AWG 8 - 0000: Elongation, 125% (minimum)  
Tensile Strength, 3000 lbf/in<sup>2</sup> (minimum)

INSULATION FLAWS:

Primary Insulation,

Spark Test, 1.5 kV (rms) at 3 kHz

Impulse Dielectric Test, 6.0 kV (peak)

Finished Wire,

Spark Test, 3.0 kV (rms) at 3 kHz

Impulse Dielectric Test, 8.0 kV (peak)

INSULATION THICKNESS:

AWG 10, .005 inch (minimum) for primary insulation  
.005 inch (minimum) for outer jacket

AWG 8 - 4, .008 inch (minimum) for primary insulation  
.012 inch (minimum) for outer jacket

AWG 2 - 0000, .010 inch (minimum) for primary insulation  
.015 inch (minimum) for outer jacket

JACKET COLOR: White preferred

SECANT MODULUS: (Test per ASTM D 882)

AWG 10: 5.0 x 10<sup>4</sup> lbf/in<sup>2</sup> (maximum)

AWG 8 and larger: 4.0 x 10<sup>4</sup> lbf/in<sup>2</sup> (maximum)

2% strain, 2 inch jaw separation, 0.2 inch/minute

SHRINKAGE: 150 ± 3°C for 6 hours,

AWG 10: .13 inch (maximum) in 12 inches

AWG 8 and larger: .25 inch (maximum) in 12 inches

VOLTAGE WITHSTAND (Post Environmental): 2500 volts (rms), 60 Hz

PART NUMBER:

The "\*" in the part numbers on page 1 shall be replaced by a color code designator.

1/ Example: AWG 2, white: CMC-0547-2-9

PRODUCT IDENTIFICATION: Mark outer jacket at 12 inch (nominal) intervals with the following:

" CMC-0547-AWG-06090 "

Black ink only for AWG 10, black ink preferred for AWG 8 and larger

1/ See footer section on page 1