

350KHZ Zero-Drift CMOS Rail-to-Rail IO HGamp with RF Filter

Features

- Single-Supply Operation from +1.8V ~ +5.5V
- Rail-to-Rail Input / Output
- Gain-Bandwidth Product:350KHz(Typ. @25°C)
- Low Input Bias Current: 20pA (Typ. @25°C)
- Low Offset Voltage: 10uV (Max. @25°C)
- Quiescent Current: 25μA per Amplifier (Typ)
- Operating Temperature: -45°C ~ +125°C
- Zero Drift: 0.05μV/°C (Typ)
- Embedded RF Anti-EMI Filter
- Small Package:

HGA330 Available in SOT23-5, SC70-5 and SOP-8 Packages

HGA2330 Available in SOP-8, MSOP-8 and DFN-8 Packages

HGA4330 Available in SOP-14 and TSSOP-14 Packages

Pin Configuration

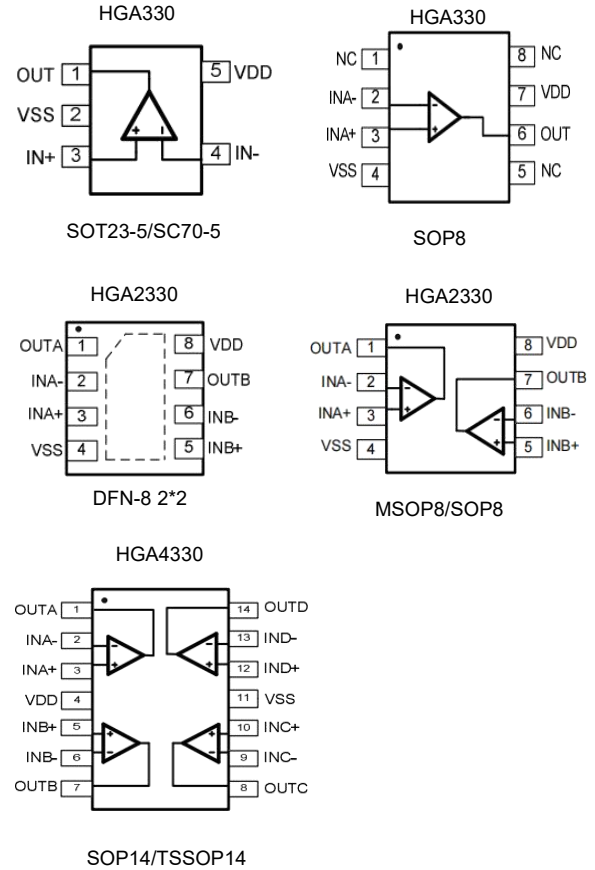

Figure 1. Pin Assignment Diagram

Ordering Information

DEVICE	Package Type	MARKING	Packing	Packing Qty
HGA330M/TR	SOP8	A330	REEL	2500pcs/Reel
HGA330M5/TR	SOT23-5	A330	REEL	3000pcs/Reel
HGA330M7/TR	SC70	A330	REEL	3000pcs/Reel
HGA2330DQ/TR	DFN8	A2330	REEL	2500pcs/Reel
HGA2330M/TR	SOP8	A2330	REEL	2500pcs/Reel
HGA2330MM/TR	MSOP8	A2330	REEL	3000pcs/Reel
HGA4330M/TR	SOP14	HGA4330	REEL	2500pcs/Reel
HGA4330MT/TR	TSSOP14	A4330	REEL	2500pcs/Reel

General Description

The HGAx330 amplifier is single/dual/quad supply, micro-power, zero-drift CMOS operational amplifiers, the amplifiers offer bandwidth of 350 kHz, rail-to-rail inputs and outputs, and single-supply operation from 1.8V to 5.5V. HGAx330 uses chopper stabilized technique to provide very low offset voltage (less than 10 μ V maximum) and near zero drift over temperature. Low quiescent supply current of 25 μ A per amplifier and very low input bias current of 20pA make the devices an ideal choice for low offset, low power consumption and high impedance applications. The HGAx330 offers excellent CMRR without the crossover associated with traditional complementary input stages. This design results in superior performance for driving analog-to-digital converters (ADCs) without degradation of differential linearity.

The HGA330 is available in SOT23-5, SC70-5 and SOP8 packages. And the HGA2330 is available in SOP8, MSOP8 and DFN-8 packages. The HGA4330 Quad is available in Green SOP-14 and TSSOP-14 packages. The extended temperature range of -45°C to +125°C over all supply voltages offers additional design flexibility.

Applications

- Transducer Application
- Temperature Measurements
- Electronics Scales
- Handheld Test Equipment
- Battery-Powered Instrumentation

Absolute Maximum Ratings

Condition	Min	Max
Power Supply Voltage (VDD to Vss)	-0.5V	+7.5V
Analog Input Voltage (IN+ or IN-)	Vss-0.5V	VDD+0.5V
PDB Input Voltage	Vss-0.5V	+7V
Operating Temperature Range	-45°C	+125°C
Junction Temperature	+160°C	
Storage Temperature Range	-55°C	+150°C
Lead Temperature (soldering, 10sec)	+260°C	
Package Thermal Resistance (TA=+25°C)		
SOP-8, θ_{JA}	125°C/W	
MSOP-8, θ_{JA}	216°C/W	
SOT23-5, θ_{JA}	190°C/W	
ESD Susceptibility		
HBM	6KV	
MM	400V	

Note: Stress greater than those listed under Absolute Maximum Ratings may cause permanent damage to the device. This is a stress rating only and functional operation of the device at these or any other conditions outside those indicated in the operational sections of this specification are not implied. Exposure to absolute maximum rating conditions for extended periods may affect reliability.

Electrical Characteristics

(At $V_s=5V$, $T_A = +25^\circ C$, $V_{CM} = V_S/2$, $R_L = 10k\Omega$, unless otherwise noted.)

PARAMETER	CONDITIONS	MIN	TYP	MAX	UNITS
INPUT CHARACTERISTICS					
Input Offset Voltage (VOS)			2	10	μV
Input Bias Current (IB)			20		μA
Input Offset Current (IOS)			10		μA
Common-Mode Rejection Ratio (CMRR)	$V_{CM} = 0V$ to $5V$		110		dB
Large Signal Voltage Gain (AVO)	$R_L = 10k\Omega$, $V_O = 0.3V$ to $4.7V$		145		dB
Input Offset Voltage Drift ($\Delta V_{OS}/\Delta T$)			50		$nV/^\circ C$
OUTPUT CHARACTERISTICS					
Output Voltage High (VOH)	$R_L = 100k\Omega$ to $-V_S$		4.998		V
	$R_L = 10k\Omega$ to $-V_S$		4.994		V
Output Voltage Low (VOL)	$R_L = 100k\Omega$ to $+V_S$		5		mV
	$R_L = 10k\Omega$ to $+V_S$		20		mV
Short Circuit Limit (ISC)	$R_L = 10\Omega$ to $-V_S$		20		mA
Output Current (IO)			30		mA
POWER SUPPLY					
Power Supply Rejection Ratio (PSRR)	$V_S = 2.5V$ to $5.5V$		115		dB
Quiescent Current (IQ)	$V_O = 0V$, $R_L = 0\Omega$		25		μA
DYNAMIC PERFORMANCE					
Gain-Bandwidth Product (GBP)	$G = +100$		350		KHz
Slew Rate (SR)	$R_L = 10k\Omega$		0.2		$V/\mu s$
NOISE PERFORMANCE					
Voltage Noise (e_n p-p)	0Hz to 10Hz		1.1		$\mu VP-P$
Voltage Noise Density (e_n)	$f = 1kHz$		70		$nV\sqrt{Hz}$

Typical Performance characteristics

($T_A=+25^{\circ}\text{C}$, $V_s=5\text{V}$, $R_L=10\text{ k}\Omega$ connected to $V_S/2$ and $V_{OUT}= V_S/2$, unless otherwise noted.)

Large Signal Transient Response

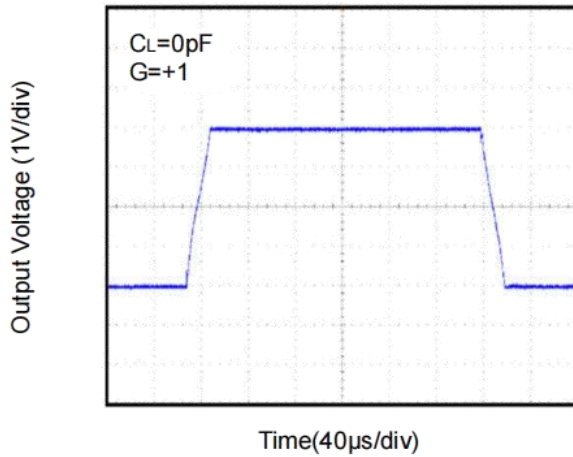

Large Signal Transient Response

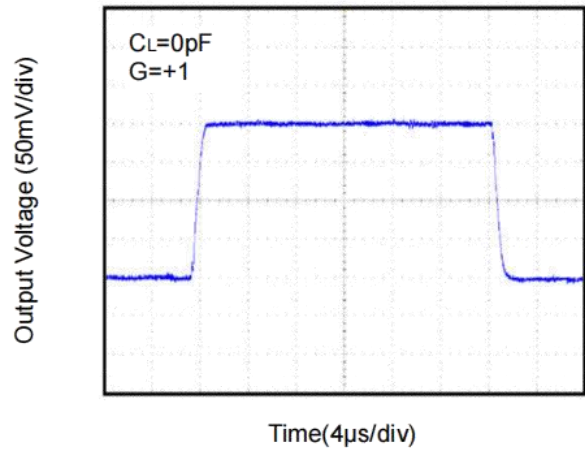

Positive Overvoltage Recovery

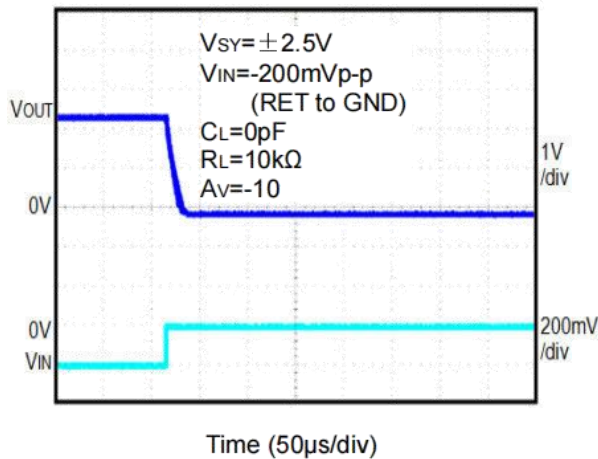

Negative Overvoltage Recovery

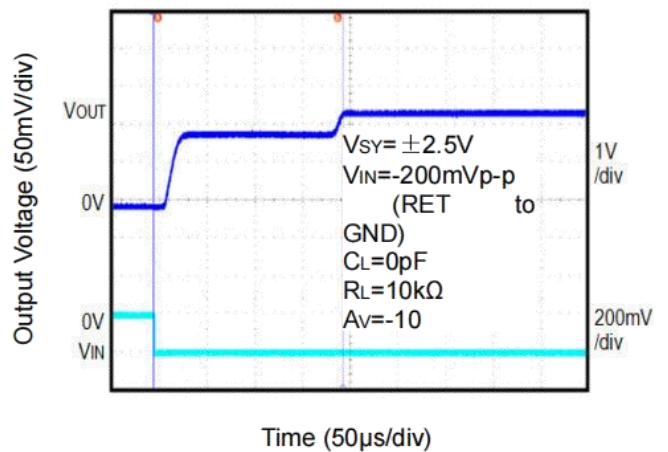

Open Loop Gain, Phase Shift vs. Frequency

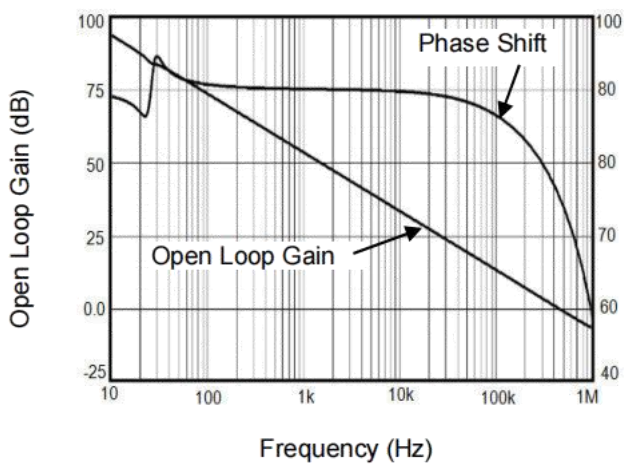

Supply Current vs. Temperature

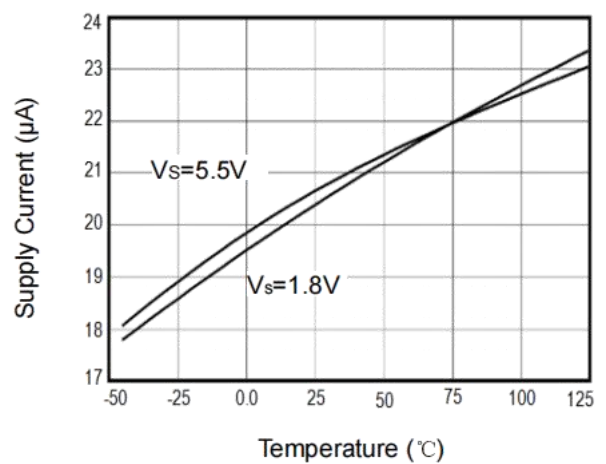

Typical Performance characteristics

(TA=+25°C, Vs=5V, RL=10 kΩ connected to VS/2 and VOUT= VS/2, unless otherwise noted.)

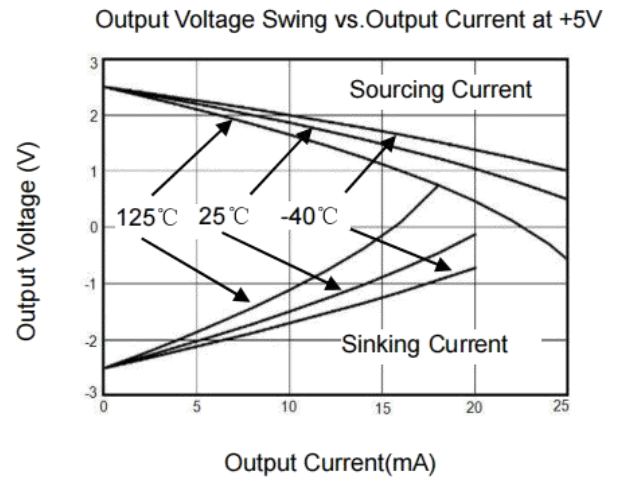
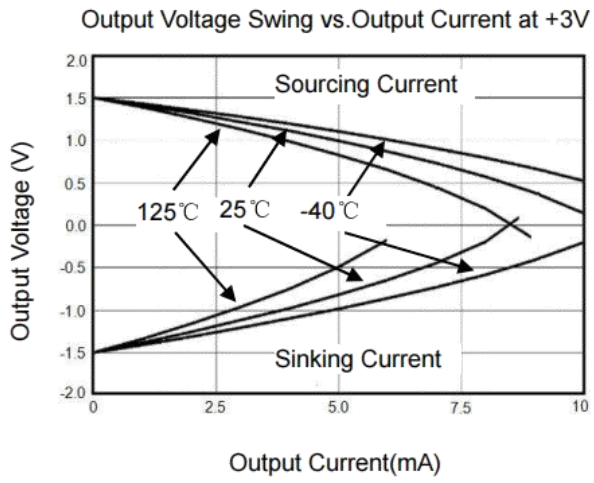

Application Note

Size

HGAx330 series op amps are unity-gain stable and suitable for a wide range of general-purpose applications. The small footprints of the HGAx330 series packages save space on printed circuit boards and enable the design of smaller electronic products.

Power Supply Bypassing and Board Layout

HGAx330 series operates from a single 1.8V to 5.5V supply or dual $\pm 0.9V$ to $\pm 2.75V$ supplies. For best performance, a $0.1\mu F$ ceramic capacitor should be placed close to the VDD pin in single supply operation. For dual supply operation, both VDD and VSS supplies should be bypassed to ground with separate $0.1\mu F$ ceramic capacitors.

Low Supply Current

The low supply current (typical 25uA per channel) of HGAx330 series will help to maximize battery life. They are ideal for battery powered systems

Operating Voltage

HGAx330 series operate under wide input supply voltage (1.8V to 5.5V). In addition, all temperature specifications apply from $-45\text{ }^{\circ}\text{C}$ to $+125\text{ }^{\circ}\text{C}$. Most behavior remains unchanged throughout the full operating voltage range. These guarantees ensure operation throughout the single Li-Ion battery lifetime

Rail-to-Rail Input

The input common-mode range of HGAx330 series extends 100mV beyond the supply rails ($V_{SS}-0.1V$ to $V_{DD}+0.1V$). This is achieved by using complementary input stage. For normal operation, inputs should be limited to this range.

Rail-to-Rail Output

Rail-to-Rail output swing provides maximum possible dynamic range at the output. This is particularly important when operating in low supply voltages. The output voltage of HGAx330 series can typically swing to less than 5mV from supply rail in light resistive loads ($>100k\Omega$), and 100mV of supply rail in moderate resistive loads ($10k\Omega$).

Capacitive Load Tolerance

The HGAx330 family is optimized for bandwidth and speed, not for driving capacitive loads. Output capacitance will create a pole in the amplifier's feedback path, leading to excessive peaking and potential oscillation. If dealing with load capacitance is a requirement of the application, the two strategies to consider are (1) using a small resistor in series with the amplifier's output and the load capacitance and (2) reducing the bandwidth of the amplifier's feedback loop by increasing the overall noise gain.

Figure 2. shows a unity gain follower using the series resistor strategy. The resistor isolates the output from the capacitance and, more importantly, creates a zero in the feedback path that compensates for the pole created by the output capacitance.

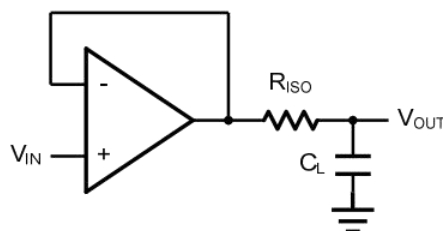

Figure 2. Indirectly Driving a Capacitive Load Using Isolation Resistor

The bigger the RISO resistor value, the more stable VOUT will be. However, if there is a resistive load RL in parallel with the capacitive load, a voltage divider (proportional to RISO/RL) is formed, this will result in a gain error.

The circuit in Figure 3 is an improvement to the one in Figure 2. RF provides the DC accuracy by feed-forward the VIN to RL. CF and RISO serve to counteract the loss of phase margin by feeding the high frequency component of the output signal back to the amplifier's inverting input, thereby preserving the phase margin in the overall feedback loop. Capacitive drive can be increased by increasing the value of CF. This in turn will slow down the pulse response.

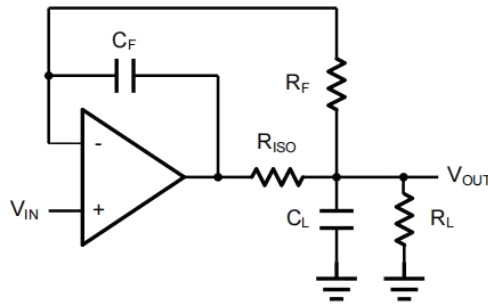

Figure 3. Indirectly Driving a Capacitive Load with DC Accuracy

Typical Application Circuits

Differential amplifier

The differential amplifier allows the subtraction of two input voltages or cancellation of a signal common to the two inputs. It is useful as a computational amplifier in making a differential to single-end conversion or in rejecting a common mode signal. Figure 4.

shown the differential amplifier using HGAx330.

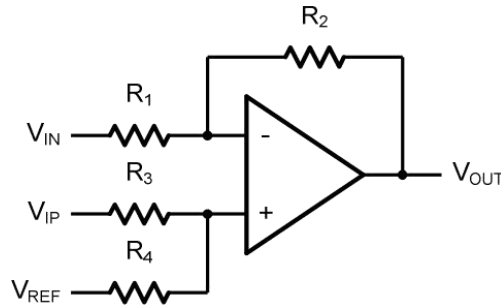

Figure 4. Differential Amplifier

$$V_{OUT} = \left(\frac{R_1 + R_2}{R_3 + R_4} \right) \frac{R_4}{R_1} V_{IN} - \frac{R_2}{R_1} V_{IP} + \left(\frac{R_1 + R_2}{R_3 + R_4} \right) \frac{R_3}{R_1} V_{REF}$$

If the resistor ratios are equal (i.e. $R_1=R_3$ and $R_2=R_4$), then

$$V_{OUT} = \frac{R_2}{R_1} (V_{IP} - V_{IN}) + V_{REF}$$

Low Pass Active Filter

The low pass active filter is shown in Figure 5. The DC gain is defined by $-R_2/R_1$. The filter has a -20dB/decade roll-off after its corner frequency $f_C=1/(2\pi R_3 C_1)$.

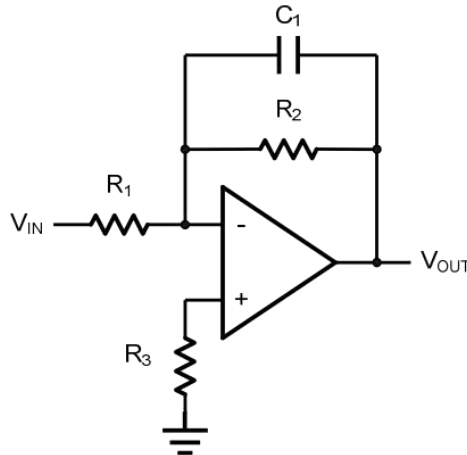

Figure 5. Low Pass Active Filter

Instrumentation Amplifier

The triple HGx330 can be used to build a three-op-amp instrumentation amplifier as shown in Figure 6. The amplifier in Figure 6 is a high input impedance differential amplifier with gain of R_2/R_1 . The two differential voltage followers assure the high input impedance of the amplifier.

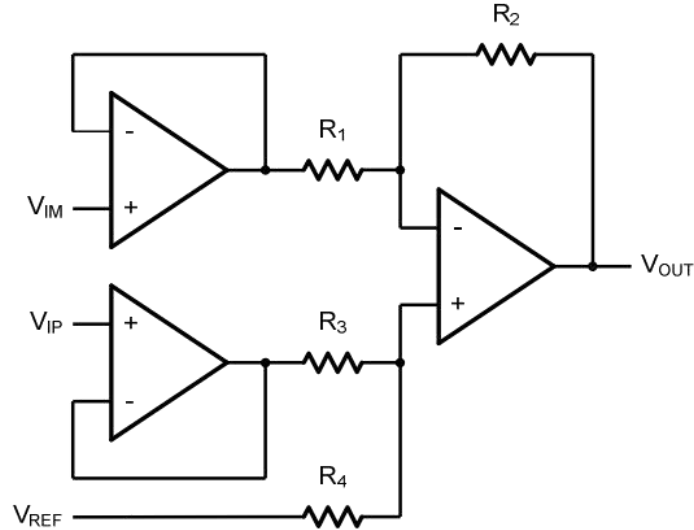
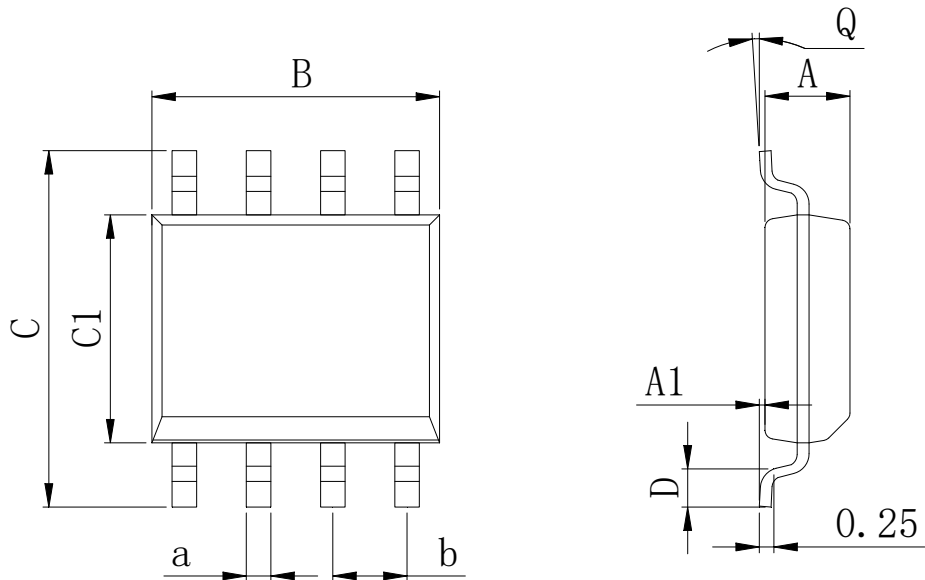
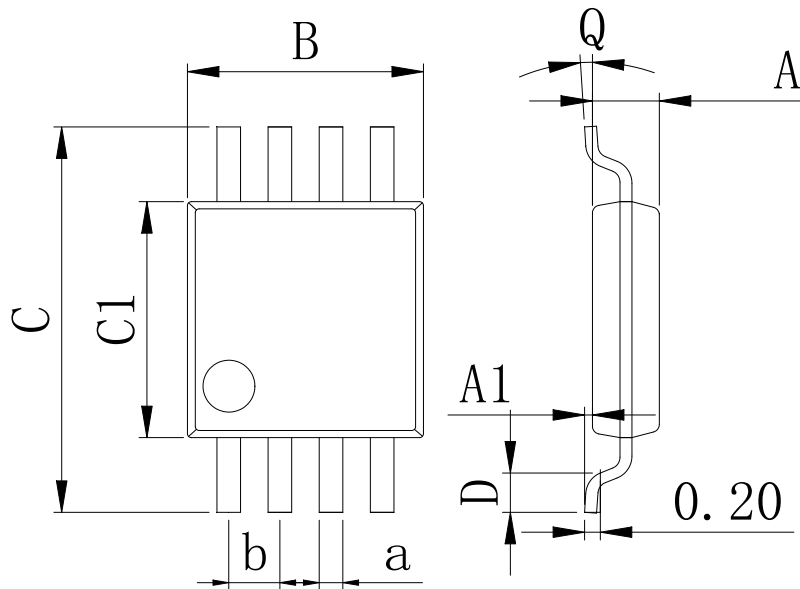

Figure 6. Instrument Amplifier

Physical Dimensions
SOP8

Dimensions In Millimeters(SOP8)

Symbol:	A	A1	B	C	C1	D	Q	a	b
Min:	1.35	0.05	4.90	5.80	3.80	0.40	0°	0.35	1.27 BSC
Max:	1.55	0.20	5.10	6.20	4.00	0.80	8°	0.45	

MSOP8

Dimensions In Millimeters(MSOP8)

Symbol:	A	A1	B	C	C1	D	Q	a	b
Min:	0.80	0.05	2.90	4.75	2.90	0.35	0°	0.25	0.65 BSC
Max:	0.90	0.20	3.10	5.05	3.10	0.75	8°	0.35	

Physical Dimensions

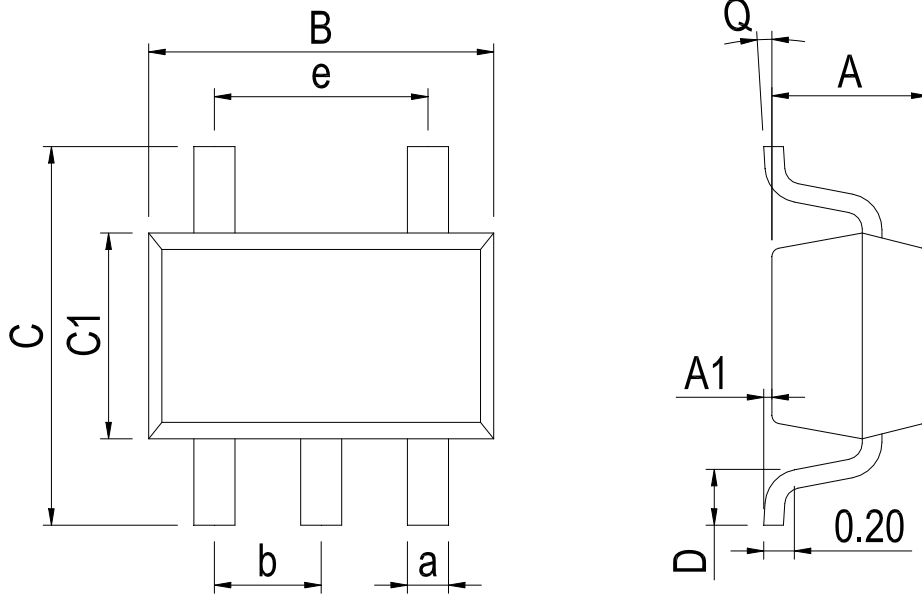
SOT23-5



Dimensions In Millimeters(SOT23-5)

Symbol:	A	A1	B	C	C1	D	Q	a	b	e
Min:	1.05	0.00	2.82	2.65	1.50	0.30	0°	0.30	0.95 BSC	1.90 BSC
Max:	1.15	0.15	3.02	2.95	1.70	0.60	8°	0.40		

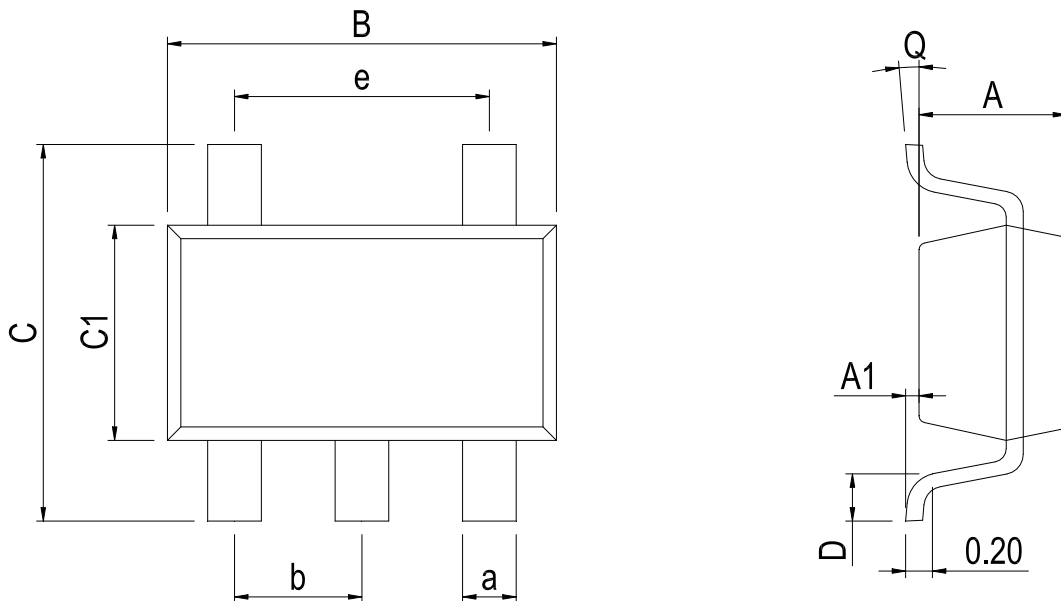
SC70-5

Dimensions In Millimeters(SC70-5)

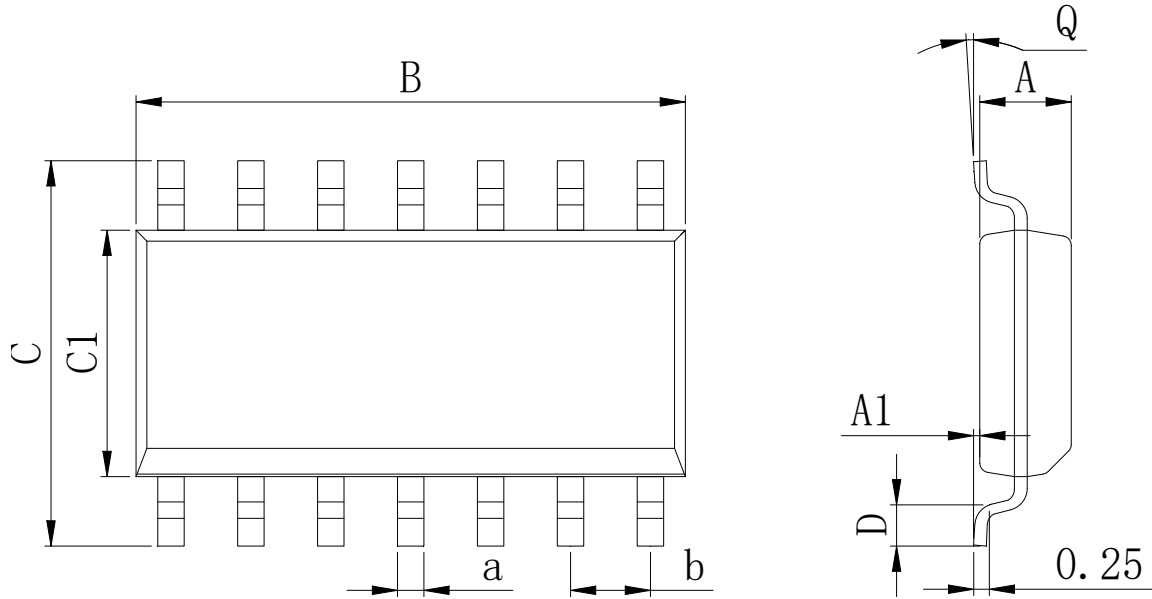
Symbol:	A	A1	B	C	C1	D	Q	a	b	e
Min:	0.90	0.00	2.00	2.15	1.15	0.26	0°	0.30	0.65 BSC	1.30 BSC
Max:	1.00	0.15	2.20	2.45	1.35	0.46	8°	0.40		

Physical Dimensions
SOP14

Dimensions In Millimeters(SOP14)									
Symbol:	A	A1	B	C	C1	D	Q	a	b
Min:	1.35	0.05	8.55	5.80	3.80	0.40	0°	0.35	1.27 BSC
Max:	1.55	0.20	8.75	6.20	4.00	0.80	8°	0.45	

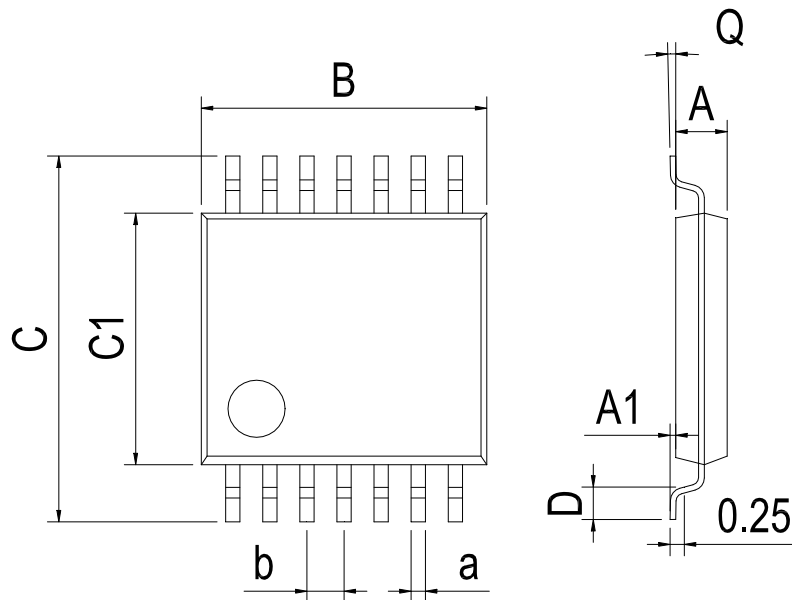
TSSOP14

Dimensions In Millimeters(TSSOP14)									
Symbol:	A	A1	B	C	C1	D	Q	a	b
Min:	0.85	0.05	4.90	6.20	4.30	0.40	0°	0.20	0.65 BSC
Max:	0.95	0.20	5.10	6.60	4.50	0.80	8°	0.25	

Physical Dimensions

DFN-8 2*2

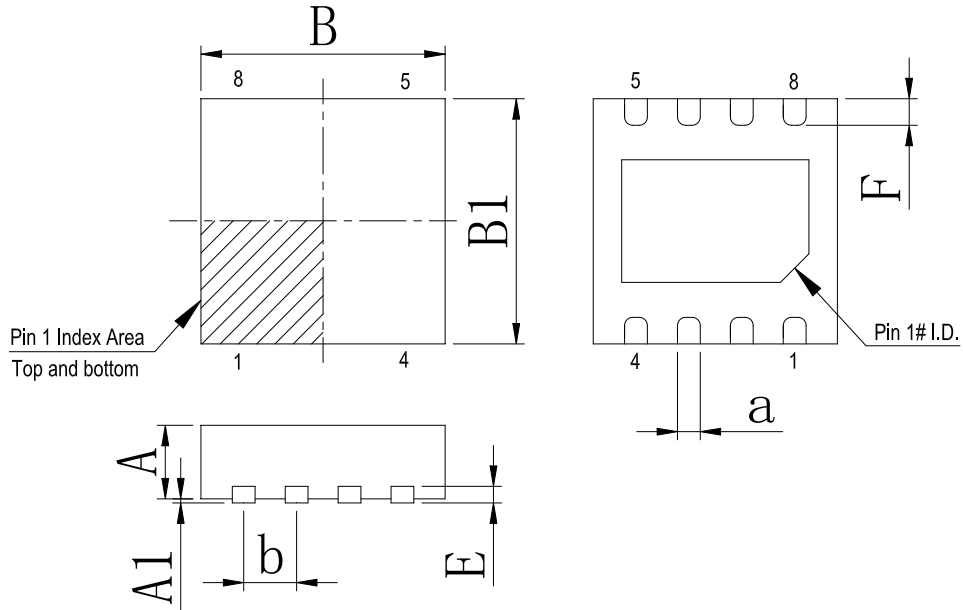

Dimensions In Millimeters(DFN-8 2*2)								
Symbol:	A	A1	B	B1	E	F	a	b
Min:	0.85	0	1.90	1.90	0.15	0.25	0.18	0.50TYP
Max:	0.95	0.05	2.10	2.10	0.25	0.45	0.30	

IMPORTANT STATEMENT:

Huaguan Semiconductor reserves the right to change its products and services without notice. Before ordering, the customer shall obtain the latest relevant information and verify whether the information is up to date and complete. Huaguan Semiconductor does not assume any responsibility or obligation for the altered documents.

Customers are responsible for complying with safety standards and taking safety measures when using Huaguan Semiconductor products for system design and machine manufacturing. You will bear all the following responsibilities: select the appropriate Huaguan Semiconductor products for your application; Design, validate and test your application; Ensure that your application meets the appropriate standards and any other safety, security or other requirements. To avoid the occurrence of potential risks that may lead to personal injury or property loss.

Huaguan Semiconductor products have not been approved for applications in life support, military, aerospace and other fields, and Huaguan Semiconductor will not bear the consequences caused by the application of products in these fields.

The technical and reliability data (including data sheets), design resources (including reference designs), application or other design suggestions, network tools, safety information and other resources provided for the performance of semiconductor products produced by Huaguan Semiconductor are not guaranteed to be free from defects and no warranty, express or implied, is made. The use of testing and other quality control technologies is limited to the quality assurance scope of Huaguan Semiconductor. Not all parameters of each device need to be tested.

The documentation of Huaguan Semiconductor authorizes you to use these resources only for developing the application of the product described in this document. You have no right to use any other Huaguan Semiconductor intellectual property rights or any third party intellectual property rights. It is strictly forbidden to make other copies or displays of these resources. You should fully compensate Huaguan Semiconductor and its agents for any claims, damages, costs, losses and debts caused by the use of these resources. Huaguan Semiconductor accepts no liability for any loss or damage caused by infringement.