

DO NOT SCALE FROM THIS PRINT

SEAF-XX-XX-X-XX-X-RA-XX-X-XR

No. OF POSITIONS
-20,-30,-40,-50
(PER ROW)

LEAD STYLE
-01

PLATING SPECIFICATION
-S: SELECTIVE GOLD,
30μ GOLD, MATTE TIN ON TAILS
(USE SUB-IM-C-242-XX-S-X)
-L: LIGHT SELECTIVE GOLD,
10μ GOLD, MATTE TIN ON TAILS
(USE SUB-IM-C-242-XX-L-X)

No. OF ROWS
-04,-06,*-08,*-10
(* = SEE NOTE 8)

PACKAGING(SEE NOTES 4, 7 & 14)
-TR: TAPE & REEL
-FR: FULL REEL QTY TAPE & REEL

PICK & PLACE OPTION
-BLANK: NO KAPTON PAD
-K: KAPTON PAD (SEE SHT 5, FIG 8)

OPTIONS
-GP: GUIDE POST HOLE
-LP: LATCH POST
(USE WITH SEAC ONLY)
(-06 ROW, ALL POS AND
-08 ROW, 40 POS ONLY)
(NOT AVAILABLE WITH -GP OPTION)

RIGHT ANGLE
-RA

SOLDER COMPOSITION (C)
& STYLE

-1: 63% TIN / 37% LEAD CHARGE TAIL
(USE SUB-IM-C-242-XX-XX-X-1)
-2: 95.5% TIN / 3.8 SILVER / 0.7% COPPER
LEAD FREE CHARGE TAIL
(USE SUB-IM-C-242-XX-XX-X-2)

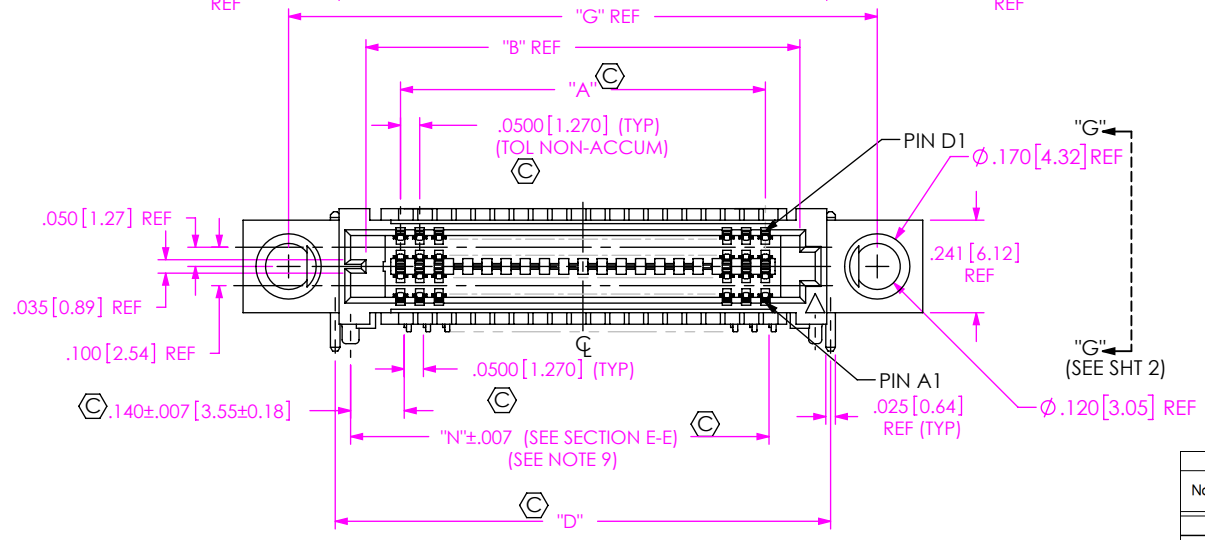
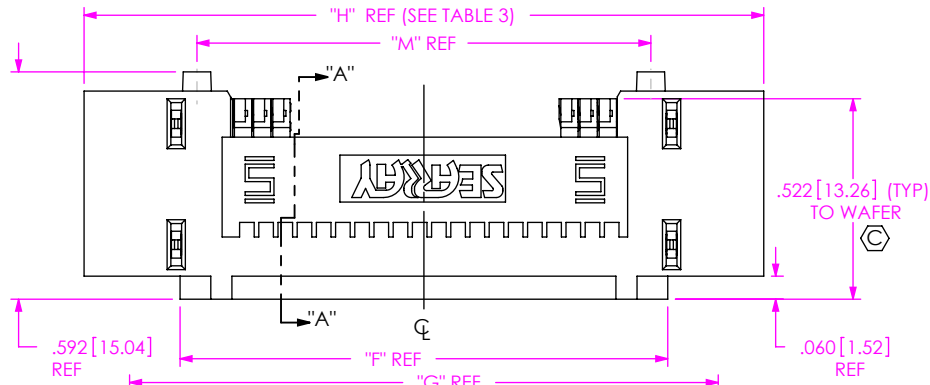

STYLE	No. OF POS PER ROW	"G"	"H"	"J"
STANDARD WITH -GP OPTION	-20	1.533 [38.94]	1.770 [44.96]	N/A
	-30	2.033 [51.64]	2.270 [57.66]	
	-40	2.533 [64.34]	2.770 [70.36]	
	-50	3.033 [77.04]	3.270 [83.06]	
WITHOUT -GP OPTION	-20	N/A	1.370 [34.80]	N/A
	-30		1.870 [47.50]	
	-40		2.370 [60.20]	
	-50		2.870 [72.90]	
WITH-LP OPTION	-20	1.533 [38.94]	1.900 [48.26]	1.790 [45.47]
	-30	2.033 [51.64]	2.400 [60.96]	2.290 [58.17]
	-40	2.533 [64.34]	2.900 [73.66]	2.790 [70.10]
	-50	3.033 [77.04]	3.400 [86.36]	3.290 [83.57]

No. OF ROWS	"BODY CALLOUT"	"SOCKET WAFER"	"WELD TAB"	"C"
-04	SEAF-XX-01-RA-04-XX	SUB-IM-C-242-01-04-X-X	WT-28-01-T	0.315 [8.00]
-06	SEAF-XX-01-RA-06-XX	SUB-IM-C-242-01-06-X-X	WT-28-02-T	0.415 [10.54]
*-08	SEAF-XX-01-RA-08-XX	SUB-IM-C-242-01-08-X-X	WT-83-01-T	0.415 [10.54]
*-10	SEAF-XX-01-RA-10-XX	SUB-IM-C-242-01-10-X-X	WT-83-02-T	0.415 [10.54]

No. OF POS. PER ROW	"A"	"B"	"D"	"E"	"F"	"N"
-20	0.950 [24.13]	1.130 [28.70]	1.290 [32.77]	1.210 [30.73]	1.270 [32.26]	1.090 [27.69]
-30	1.450 [36.83]	1.630 [41.40]	1.790 [45.47]	1.710 [43.43]	1.770 [44.96]	1.590 [40.39]
-40	1.950 [49.53]	2.130 [54.10]	2.290 [58.17]	2.210 [56.13]	2.270 [57.66]	2.090 [53.09]
-50	2.450 [62.23]	2.630 [66.80]	2.790 [70.87]	2.710 [68.83]	2.770 [70.36]	2.590 [65.79]

No. OF ROWS	"M"				"BACK STRAP"
	20 POS	30 POS	40 POS	50 POS	
-04	1.182 [30.02]	1.682 [42.72]	2.182 [55.42]	2.682 [68.12]	N/A
-06,*-08 & *-10	N/A	N/A	N/A	N/A	SEAX-RA-BS-XX-01

NOTES:
1. (C) REPRESENTS A CRITICAL DIMENSION.
2. MINIMUM PUSH-OUT FORCE: .50 LBS[2.2N].
3. INSPECT DIMENSION AT FIRST POSITION WAFER LOCATION ONLY, FIRST AND LAST PIN.
4. TAPE & REEL IS STANDARD PACKAGING.
5. NOTE DELETED
6. NOTE DELETED
7. ATTACH LABEL-4X2 TO EACH REEL.
8. ON -08 & -10 ROW ASSEMBLIES, SEE FIG 10, SHEET 5 FOR CAT FIXTURE VIEW.
9. CHECK DIMENSION ON FIRST AND LAST ROW OF TAILS.
10. A 20-30°C TEMPERATURE DIFFERENCE MAY EXIST BETWEEN THIS HIGH-DENSITY COMPONENT AND THE BOARD SURFACE DURING REFLOW. SAMTEC RECOMMENDS A THERMAL STUDY BE PERFORMED TO UNDERSTAND THE TEMPERATURE GRADIENTS YOU MAY EXPERIENCE.
11. SOME RELAXATION/WARPING OF THE BACK STRAP IS ACCEPTABLE AFTER PROCESSING.
12. SEE SHEET 5 FOR PROCESSING INFORMATION.
13. VOID PATTERN MAY VARY BY ROW AND END OPTION.
14. ORDERS WILL BE PACKAGED ACCORDING TO THE SAMTEC PACKAGING EFFICIENCY STANDARDS (SPES) FOUND ON WWW.SAMTEC.COM

FIG 1
(SEAF-20-01-X-04-X-RA-GP)
(SOME DETAIL OMITTED FOR CLARITY)

UNLESS OTHERWISE SPECIFIED, DIMENSIONS ARE IN INCHES.
TOLERANCES ARE:
DECIMALS ANGLES
.XX: ±.01 [.3] 2°
.XXX: ±.005 [.13]
.XXXX: ±.0020 [.051]

PROPRIETARY NOTE
THIS DOCUMENT CONTAINS CONFIDENTIAL AND PROPRIETARY INFORMATION AND ALL DESIGN, MANUFACTURING, REPRODUCTION, USE, PATENT RIGHTS AND SALES RIGHTS ARE EXPRESSLY RESERVED BY SAMTEC, INC. THIS DOCUMENT SHALL NOT BE DISCLOSED, IN WHOLE OR PART, TO ANY UNAUTHORIZED PERSON OR ENTITY NOR REPRODUCED, TRANSFERRED OR INCORPORATED IN ANY OTHER PROJECT IN ANY MANNER WITHOUT THE EXPRESS WRITTEN CONSENT OF SAMTEC, INC.



520 PARK EAST BLVD, NEW ALBANY, IN 47150
PHONE: 812-944-6733 FAX: 812-948-5047
e-Mail info@SAMTEC.com code 55322

MATERIAL: DO NOT SCALE DRAWING SHEET SCALE: 2:1
INSULATOR: LCP COLOR: BLACK UL 94 V-0
CONTACT: COPPER ALLOY .006 THICK

DESCRIPTION:
SEAF-RA ASSEMBLY
DWG. NO.
SEAF-XX-XX-X-XX-X-RA-XX-X-XR
BY: C. PIERCE 12/15/2007 SHEET 1 OF 5

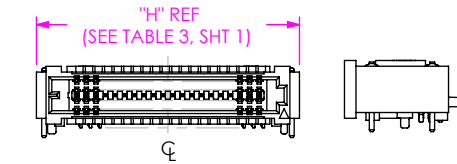
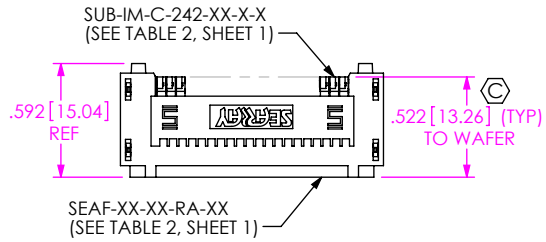

FIG 2
(SEAF-20-01-X-04-X-RA SHOWN)
(SAME AS FIG 1 EXCEPT AS NOTED)
(SOME DETAIL REMOVED FOR CLARITY)

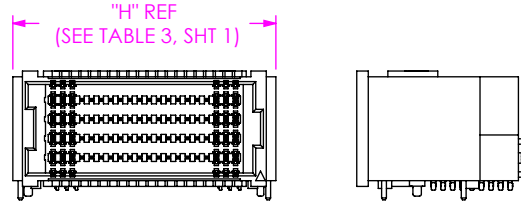
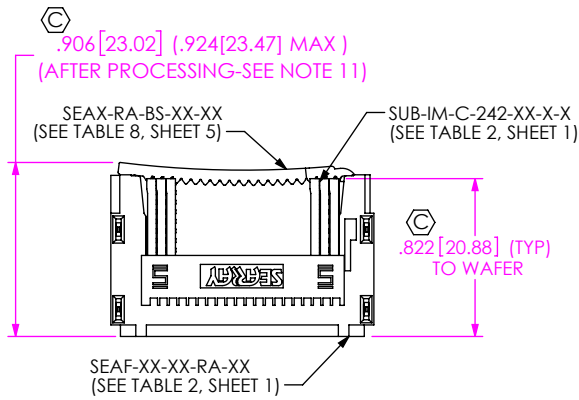

FIG 9
(SEAF-20-01-X-10-X-RA SHOWN)
(SAME AS FIG 4 EXCEPT AS NOTED)
(SOME DETAIL REMOVED FOR CLARITY)

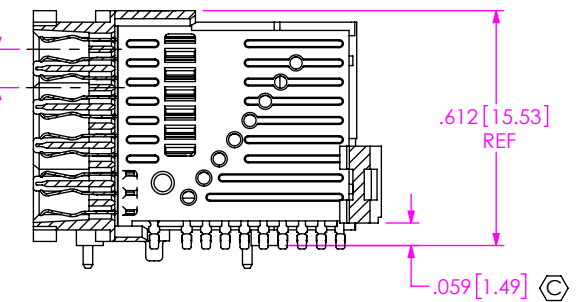
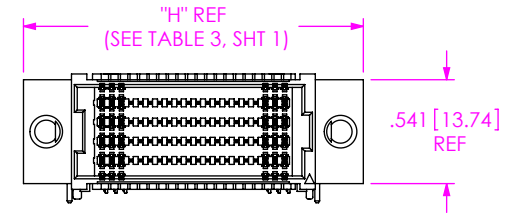
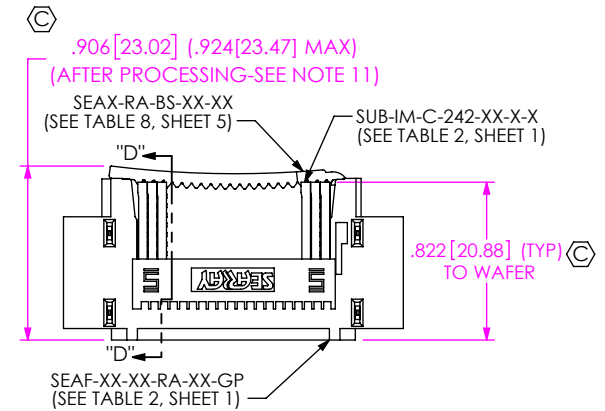

FIG 4
(SEAF-20-01-X-10-X-RA-GP)
(SAME AS FIG 1 EXCEPT AS NOTED)
(SOME DETAIL REMOVED FOR CLARITY)

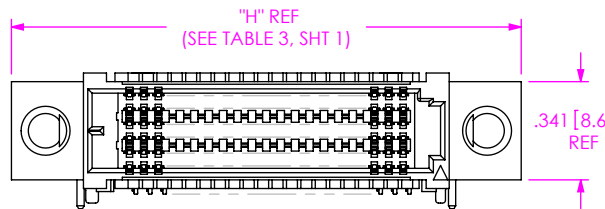
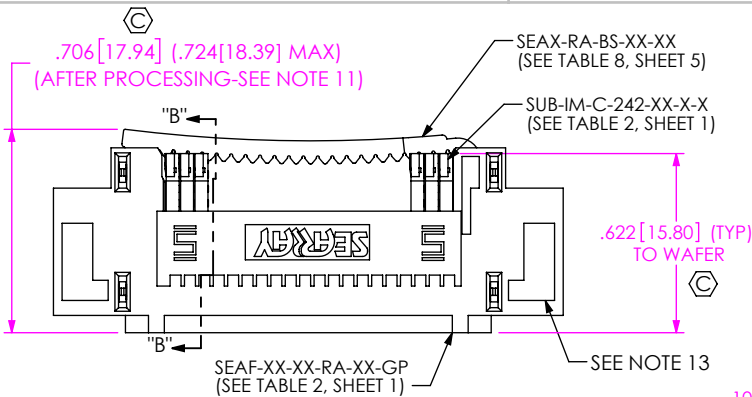
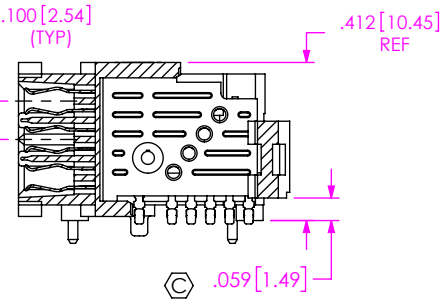

FIG 3
(SEAF-20-01-X-06-X-RA-GP)
(SAME AS FIG 1 EXCEPT AS NOTED)
(SOME DETAIL REMOVED FOR CLARITY)



SECTION "B"-"B"
SCALE 2 : 1

PROPRIETARY NOTE
THIS DOCUMENT CONTAINS CONFIDENTIAL AND PROPRIETARY INFORMATION AND ALL DESIGN, MANUFACTURING, REPRODUCTION, USE, PATENT RIGHTS AND SALES RIGHTS ARE EXPRESSLY RESERVED BY SAMTEC, INC. THIS DOCUMENT SHALL NOT BE DISCLOSED, IN WHOLE OR PART, TO ANY UNAUTHORIZED PERSON OR ENTITY NOR REPRODUCED, TRANSFERRED OR INCORPORATED IN ANY OTHER PROJECT IN ANY MANNER WITHOUT THE EXPRESS WRITTEN CONSENT OF SAMTEC, INC.



520 PARK EAST BLVD, NEW ALBANY, IN 47150
PHONE: 812-944-6733 FAX: 812-948-5047
e-Mail info@SAMTEC.com code 55322

DO NOT SCALE DRAWING
SHEET SCALE: 1:1

DESCRIPTION:
SEAF-RA ASSEMBLY
DWG. NO.
SEAF-XX-XX-X-XX-X-RA-XX-X-R

BY: C. PIERCE 12/15/2007 SHEET 3 OF 5

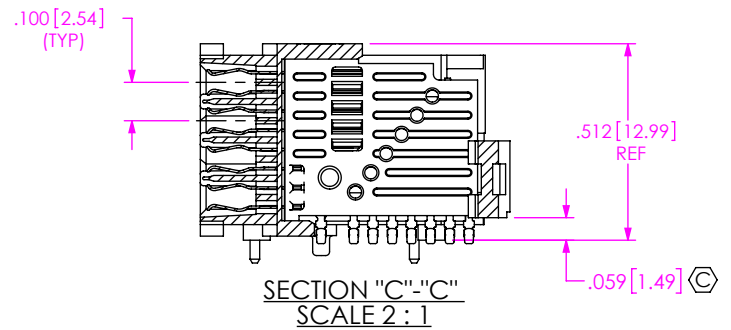
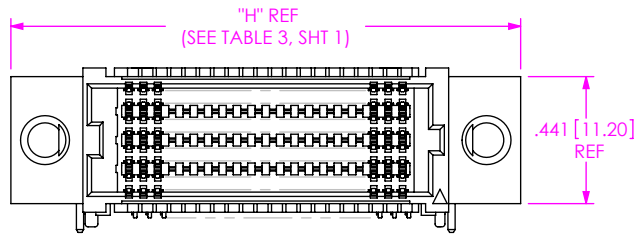
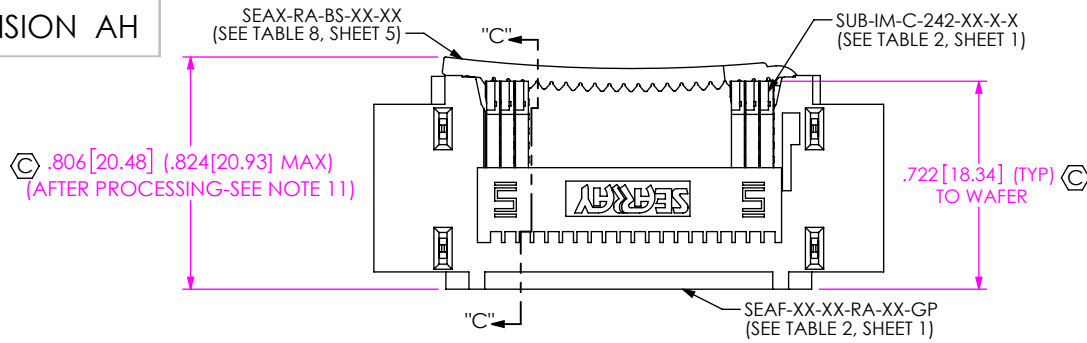

FIG 5
(SEAF-20-01-X-08-X-RA-GP)
(SAME AS FIG 1 EXCEPT AS NOTED)
(SOME DETAIL REMOVED FOR CLARITY)

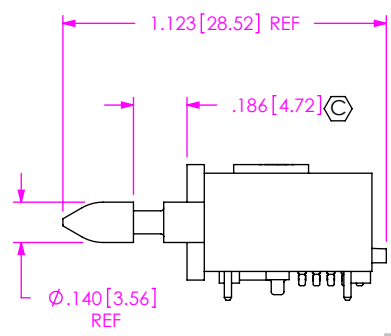
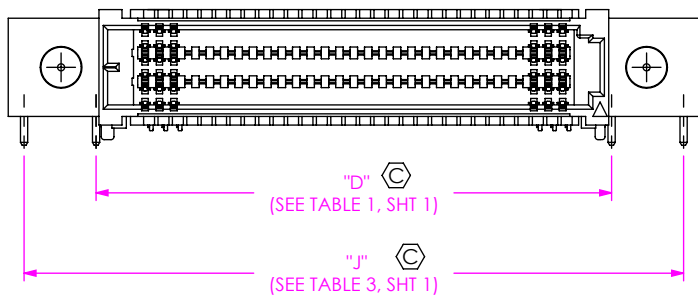
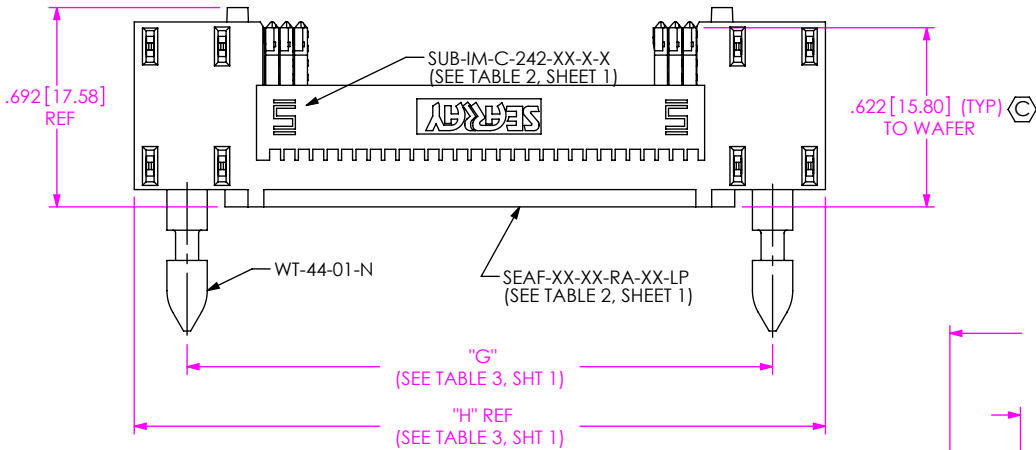

FIG 6
(SEAF-30-01-X-06-X-RA-LP)
(SOME DETAIL OMITTED FOR CLARITY)
(SAME AS FIG 3 EXCEPT AS SHOWN)

<p>DO NOT SCALE DRAWING</p> <p>SHEET SCALE: 1:1</p>	<p>PROPRIETARY NOTE</p> <p>THIS DOCUMENT CONTAINS CONFIDENTIAL AND PROPRIETARY INFORMATION AND ALL DESIGN, MANUFACTURING, REPRODUCTION, USE, PATENT RIGHTS AND SALES RIGHTS ARE EXPRESSLY RESERVED BY SAMTEC, INC. THIS DOCUMENT SHALL NOT BE DISCLOSED, IN WHOLE OR PART, TO ANY UNAUTHORIZED PERSON OR ENTITY NOR REPRODUCED, TRANSFERRED OR INCORPORATED IN ANY OTHER PROJECT IN ANY MANNER WITHOUT THE EXPRESS WRITTEN CONSENT OF SAMTEC, INC.</p>	<p>samtec</p> <p>520 PARK EAST BLVD, NEW ALBANY, IN 47150 PHONE: 812-944-6733 FAX: 812-948-5047 e-Mail info@SAMTEC.com code 55322</p>
	<p>DESCRIPTION: SEAF-RA ASSEMBLY</p>	
	<p>DWG. NO. SEAF-XX-XX-X-XX-X-RA-XX-X-XR</p>	
	<p>BY: C. PIERCE 12/15/2007</p>	<p>SHEET 4 OF 5</p>

ROWS	TABLE 5																
	"L"		"P" ϕ		"K" NO -GP OPTION				"K" WITH -GP OPTION				"K" WITH -LP OPTION				"Q"
				20 POS	30 POS	40 POS	50 POS	20 POS	30 POS	40 POS	50 POS	20 POS	30 POS	40 POS	50 POS		
-04	.276	[7.01]	.295	[7.49]	.538 [13.65]	.788 [20.00]	1.038 [26.35]	1.288 [32.70]	.738 [18.73]	.988 [25.08]	1.238 [31.43]	1.488 [37.78]	N/A	N/A	N/A	N/A	.124 [3.15]
-06	.376	[9.55]	.295	[7.49]	.538 [13.65]	.788 [20.00]	1.040 [26.40]	1.288 [32.70]	.738 [18.73]	.988 [25.08]	1.238 [31.43]	1.488 [37.78]	.803 [20.38]	1.053 [26.73]	1.303 [33.08]	1.553 [39.43]	.124 [3.15]
-08	.483	[12.27]	.649	[16.48]	.361 [9.16]	.611 [15.51]	.861 [21.86]	1.111 [28.21]	.561 [14.24]	.811 [20.59]	1.061 [26.94]	1.311 [33.29]	.626 [15.89]	.876 [22.24]	1.126 [28.59]	1.376 [34.94]	.030 [0.76]
-10	.583	[14.81]	.649	[16.48]	.361 [9.16]	.611 [15.51]	.861 [21.86]	1.111 [28.21]	.561 [14.24]	.811 [20.59]	1.061 [26.94]	1.311 [33.29]	N/A	N/A	N/A	N/A	.030 [0.76]

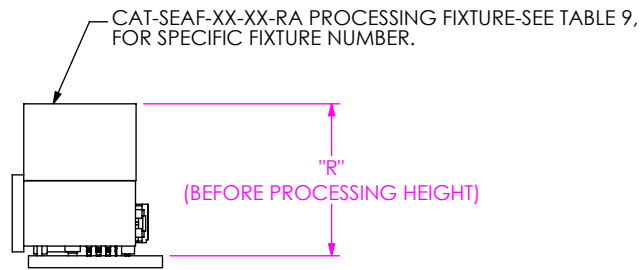
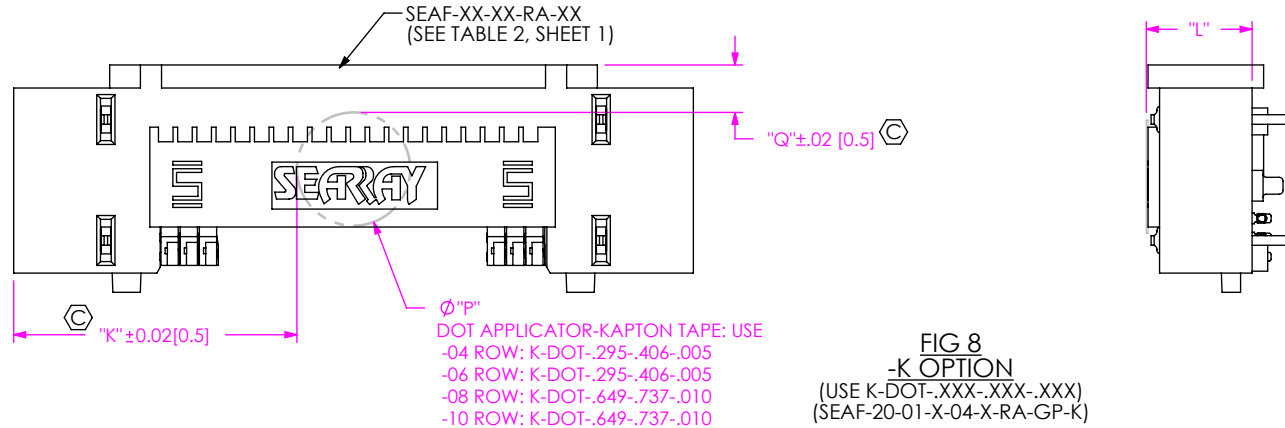

TABLE 7	
ROW	"R"
-08	.892 [22.66]
-10	.992 [25.20]

NOTE:
 FIG 10, DIMENSION "R" INDICATES CONNECTOR/FIXTURE HEIGHT ON PCB. TO GUARANTEE ENOUGH REFLOW OVEN WORKING SPACE, DIMENSION "R", PCB THICKNESS, AND THE HEIGHT OF THE COMPONENTS ON THE OPPOSITE SIDE OF THE BOARD NEED TO BE CONSIDERED.

FIG 10
 SEAF-RA PROCESSING FIXTURE
 (USE CAT-SEAF-XX-XX-RA FIXTURE)

TABLE 9		
SEARAY™ FIXTURE TOOLS		
PART NUMBER	POSITIONS	ROW
CAT-SEAF-20-01-RA	20	-08 AND -10
CAT-SEAF-30-01-RA	30	-08 AND -10
CAT-SEAF-40-01-RA	40	-08 AND -10
CAT-SEAF-50-01-RA	50	-08 AND -10

TABLE 8	
No. OF POSITIONS	"BACKSTRAP"
-20	SEAX-RA-BS-20-01
-30	SEAX-RA-BS-30-01
-40	SEAX-RA-BS-40-01
-50	SEAX-RA-BS-50-01

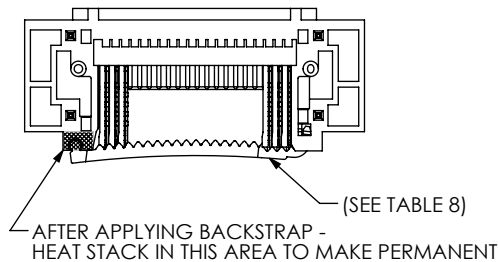

FIG 11
 HEAT STAKING BACKSTRAP

PROPRIETARY NOTE
 THIS DOCUMENT CONTAINS CONFIDENTIAL AND PROPRIETARY INFORMATION AND ALL DESIGN, MANUFACTURING, REPRODUCTION, USE, PATENT RIGHTS AND SALES RIGHTS ARE EXPRESSLY RESERVED BY SAMTEC, INC. THIS DOCUMENT SHALL NOT BE DISCLOSED, IN WHOLE OR PART, TO ANY UNAUTHORIZED PERSON OR ENTITY NOR REPRODUCED, TRANSFERRED OR INCORPORATED IN ANY OTHER PROJECT IN ANY MANNER WITHOUT THE EXPRESS WRITTEN CONSENT OF SAMTEC, INC.

samtec
 520 PARK EAST BLVD, NEW ALBANY, IN 47150
 PHONE: 812-944-6733 FAX: 812-948-5047
 e-Mail info@SAMTEC.com code 55322

DO NOT SCALE DRAWING
 SHEET SCALE: 2:1

DESCRIPTION:
 SEAF-RA ASSEMBLY

DWG. NO.
 SEAF-XX-XX-X-XX-X-RA-XX-X-XR

BY: C. PIERCE 12/15/2007 SHEET 5 OF 5