



BMB60N076UC1

N-Channel Power MOSFET

600 V, 52 A, 76 mΩ

Description

BMB60N076UC1 is power MOSFET using bestirpower's advanced super junction technology that can realize very low on resistance and gate charge.

It will provide much high efficiency by using optimized charge coupling technology. These user friendly devices give an advantage of Low EMI to designers as well as low switching loss.

Applications

- PC power.
- Server power supply.
- Telecom.
- Solar inverter.
- Super charger for automobiles.

Features

$BV_{DSS}@T_{J,max}$	I_D	$R_{DS(on),max}$	$Q_{g,typ}$
650 V	52 A	76 mΩ	80 nC

- Ultra-fast body diode.
- Extremely low losses due to very low FOM $R_{dson} * Q_g$ and E_{oss} .
- Very high commutation ruggedness.

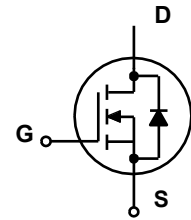
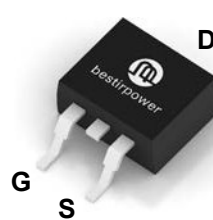

Absolute Maximum Ratings ($T_C = 25^\circ\text{C}$ unless otherwise noted)

Symbol	Parameter	Value	Unit
V_{DSS}	Drain to Source Voltage ¹⁾	600	V
V_{GSS}	Gate to Source Voltage	± 30	V
I_D	Drain Current ²⁾	Continuous ($T_C = 25^\circ\text{C}$)	52
		Continuous ($T_C = 125^\circ\text{C}$)	23
I_{DM}	Drain Current	Pulsed	155
E_{AS}	Single Pulsed Avalanche Energy ³⁾	625	mJ
I_{AR}	Avalanche Current	5	A
dv/dt	MOSFET dv/dt	50	V/ns
	Peak Diode Recovery dv/dt ⁴⁾	50	
P_D	Power Dissipation ($T_C = 25^\circ\text{C}$)	500	W
T_J, T_{STG}	Operating and Storage Temperature Range	-55 to 150	$^\circ\text{C}$
T_L	Maximum Lead Temperature for Soldering, 1/8" from Case for 10 Seconds	260	$^\circ\text{C}$

1) Limited by T_j max. Maximum duty cycle $D=0.75$.

2) Pulse width t_p limited by T_j,max .

3) $V_{DD}=50\text{V}$, $R_G=25\Omega$, Starting $T_j=25^\circ\text{C}$.

4) $V_{DClkink}=400\text{V}$; $V_{DS,peak} < V_{(BR)DSS}$; identical low side and high side switch with identical R_G .

Thermal Characteristics

Symbol	Parameter	Value	Unit
$R_{\theta JC}$	Thermal Resistance, Junction to Case, Max.	0.25	$^\circ\text{C/W}$
$R_{\theta JA}$	Thermal Resistance, Junction to Ambient, Max.	62	

Package Marking and Ordering Information

Part Number	Top Marking	Package	Packing Method	Quantity
BMB60N076UC1	BMB60N076UC1	TO-263(D ² PAK)	Tape & Reel	800units

Electrical Characteristics (T_C = 25°C unless otherwise noted)

Symbol	Parameter	Test Conditions	Min	Typ	Max	Unit
--------	-----------	-----------------	-----	-----	-----	------

Off Characteristics

BV _{DSS}	Drain to Source Breakdown Voltage	V _{GS} = 0 V, I _D = 1 mA	600	-	-	V
I _{DSS}	Zero Gate Voltage Drain Current	V _{DS} = 600 V, V _{GS} = 0 V, T _J = 25°C	-	-	10	μA
I _{GSS}	Gate-Source Leakage Current	V _{GS} = ±30 V, V _{DS} = 0 V	-	-	±100	nA

On Characteristics

V _{GS(th)}	Gate Threshold Voltage	V _{GS} = V _{DS} , I _D = 1 mA	3.0	4.0	5.0	V
R _{DS(on)}	Static Drain to Source On Resistance	V _{GS} = 10 V, I _D = 23 A, T _J = 25°C	-	70	76	mΩ

Dynamic Characteristics

C _{iss}	Input Capacitance	V _{GS} = 0 V, V _{DS} = 50V, f = 250 kHz	-	3440	-	pF
C _{oss}	Output Capacitance		-	162	-	pF
C _{rss}	Reverse transfer capacitance		-	7	-	pF
C _{o(tr)}	Time Related Output Capacitance ¹⁾	V _{DS} = 0 V to 400 V, V _{GS} = 0 V	-	557	-	pF
C _{o(er)}	Energy Related Output Capacitance ²⁾		-	107	-	pF
Q _{g(tot)}	Total Gate Charge at 10 V	V _{DD} = 400 V, I _D = 23 A, V _{GS} = 0 to 10 V	-	80	-	nC
Q _{gs}	Gate to Source Charge		-	19	-	nC
Q _{gd}	Gate to Drain "Miller" Charge		-	34	-	nC
V _{plateau}	Gate plateau voltage		-	6	-	V

Switching Characteristics

t _{d(on)}	Turn-On Delay Time	V _{DD} = 400 V, I _D = 23 A, V _{GS} = 10 V	-	85	-	ns
t _r	Turn-On Rise Time		-	14	-	ns
t _{d(off)}	Turn-Off Delay Time		-	130	-	ns
t _f	Turn-Off Fall Time		-	14	-	ns

Source-Drain Diode Characteristics

V _{SD}	Diode Forward Voltage	V _{GS} = 0 V, I _F = 23 A, T _F = 25°C	-	0.89	-	V
t _{rr}	Reverse Recovery Time	V _R = 400 V, I _F = 23 A, di _F /dt = 100 A/μs	-	145	-	ns
Q _{rr}	Reverse Recovery Charge		-	1.15	-	μC
I _{rrm}	Peak reverse recovery current		-	14	-	A

- 1) C_{o(tr)} is a fixed capacitance that gives the same charging time as C_{oss} while V_{DS} is rising from 0 to 400V.
- 2) C_{o(er)} is a fixed capacitance that gives the same stored energy as C_{oss} while V_{DS} is rising from 0 to 400

Typical Performance Characteristics

Figure 1. Power dissipation

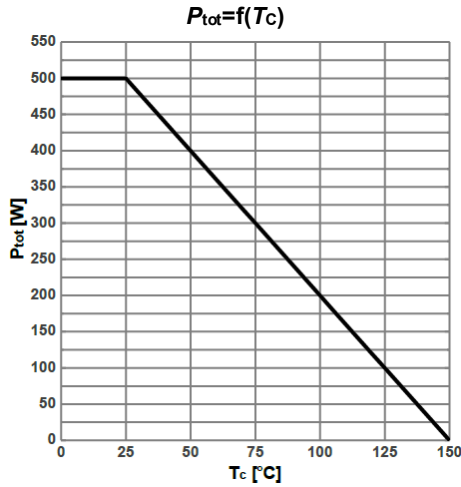

Figure 2. Max. transient thermal impedance

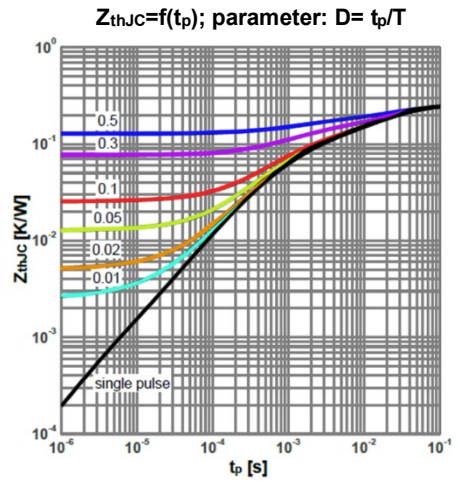

Figure 3. Safe operating area

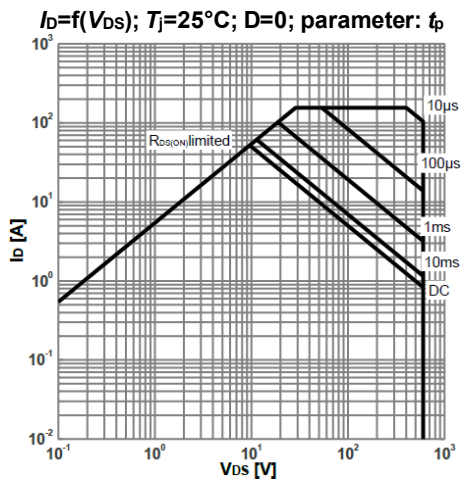

Figure 4. Typ. Output characteristics

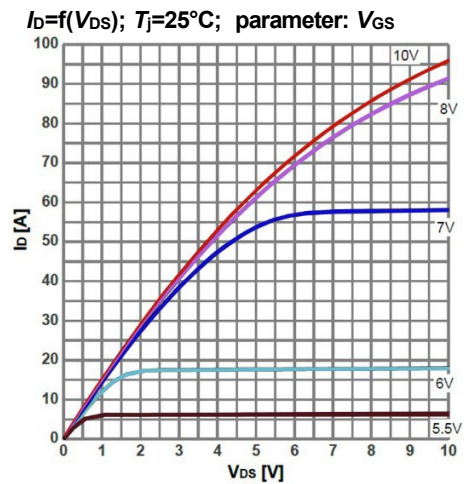

Figure 5. Typ. Output characteristics

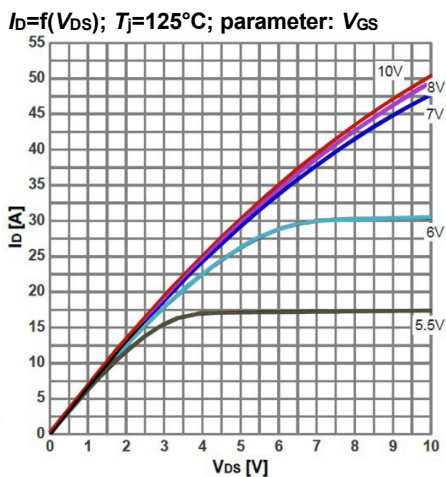
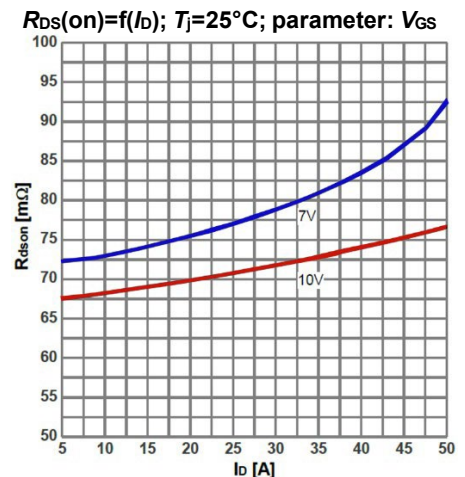

Figure 6. Typ. drain-source on-state resistance



Typical Performance Characteristics

Figure 7. Typ. drain-source on-state resistance

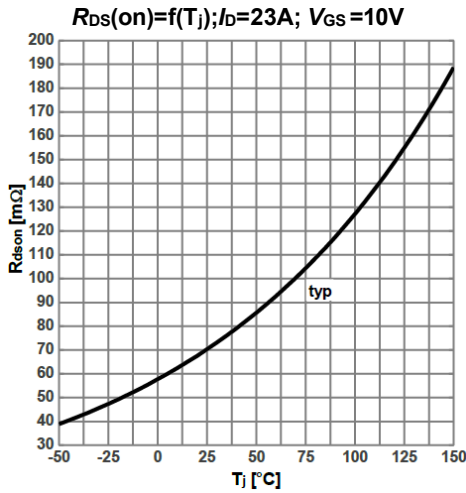

Figure 8. Typ. Transfer characteristics

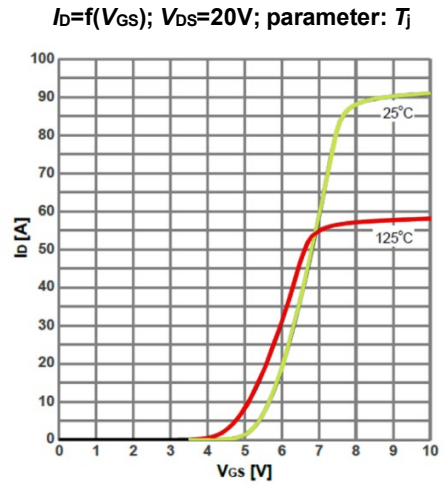

Figure 9. Typ. gate charge

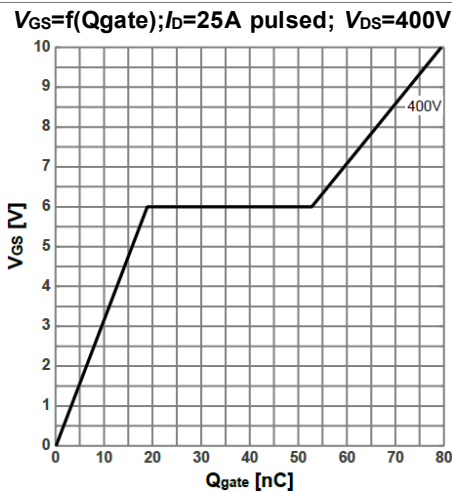

Figure 10. Typ. forward characteristics of reverse diode

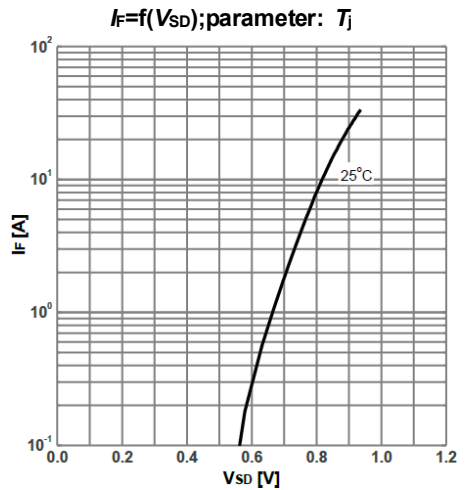

Figure 11. Typ. drain-source breakdown voltage

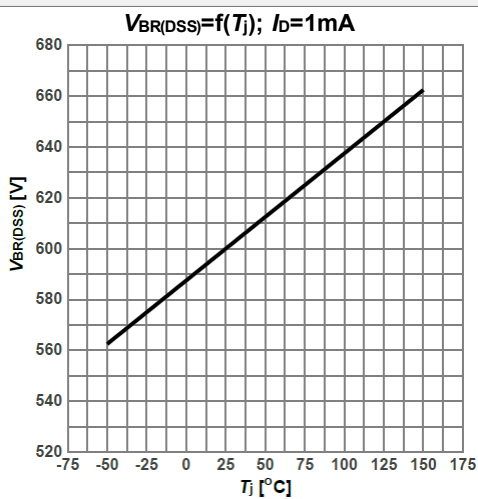
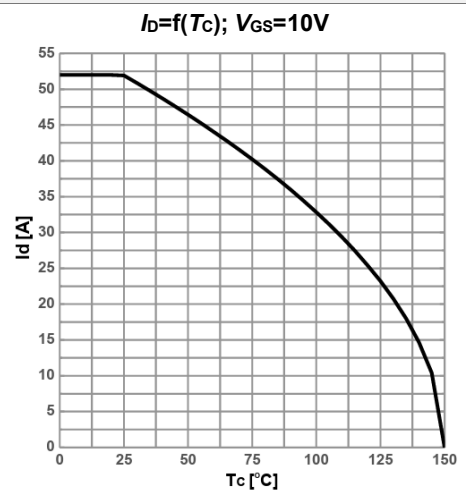

Figure 12. Maximum drain current



Typical Performance Characteristics

Figure 13. Typ. Capacitances

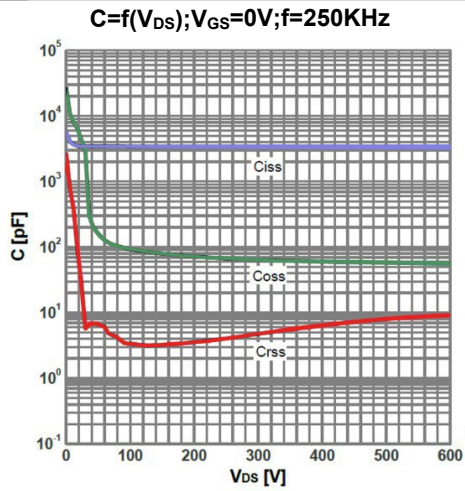
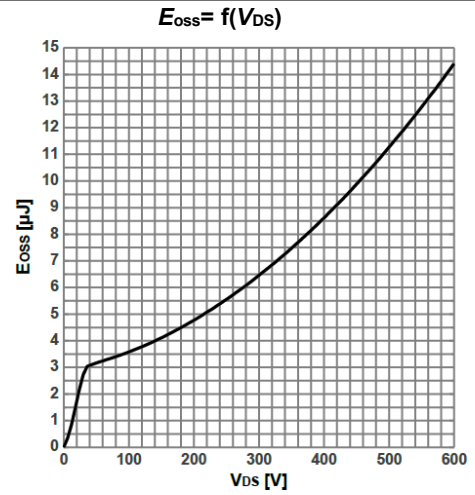

Figure 14. Typ. c_{oss} stored energy



Test Circuits

Figure 15. Diode Characteristics

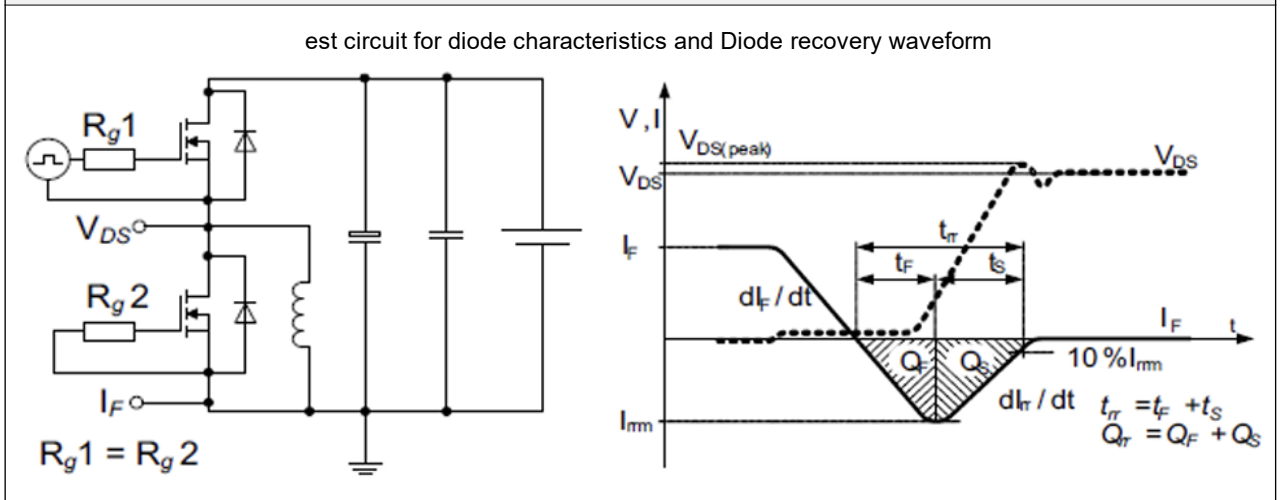

Figure 16. Switching Times

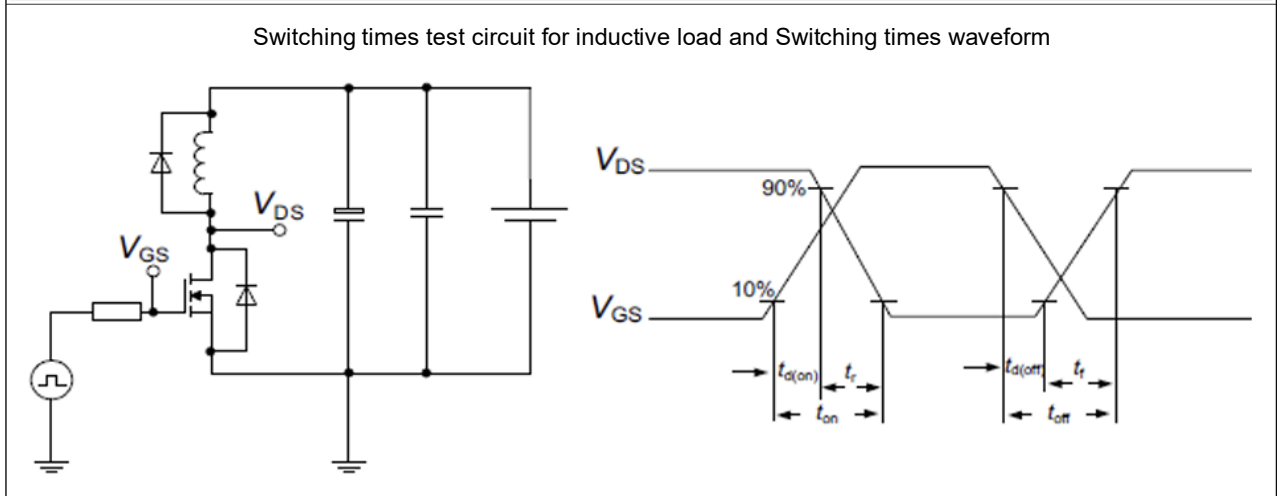
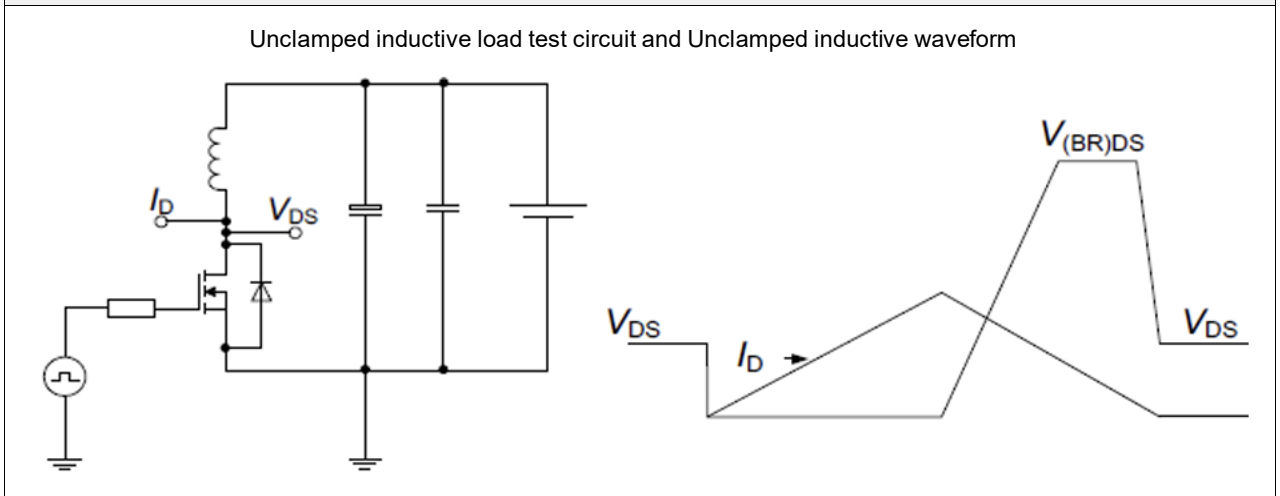
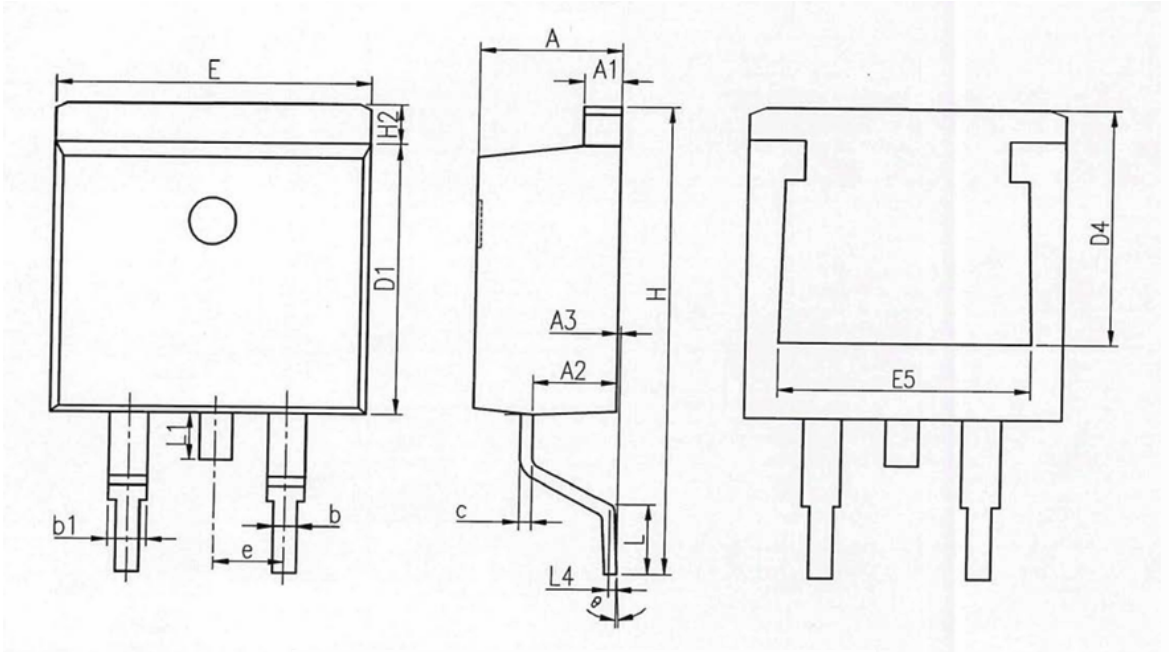

Figure 17. Unclamped Inductive Load



Package Outlines

TO263-2L



COMMON DIMENSIONS

SYMBOL	MM		
	MIN	NOM	MAX
A	4.37	4.57	4.77
A1	1.22	1.27	1.42
A2	2.49	2.69	2.89
A3	0.00	0.13	0.25
b	0.70	0.81	0.96
b1	1.17	1.27	1.47
c	0.30	0.38	0.53
D1	8.50	8.70	8.90
D4	6.60	-	-
E	9.86	10.16	10.36
E5	7.06	-	-
e	2.54 BSC		
H	14.70	15.10	15.50
H2	1.07	1.27	1.47
L	2.00	2.30	2.60
L1	1.40	1.55	1.70
L4	0.25 BSC		
θ	0°	5°	9°

* Dimensions in millimeters

Disclaimer

Bestirpower reserve the right to make changes, corrections, enhancements, modifications, and improvements to Bestirpower products and/or to this document at any time without notice.

The information given in this document shall in no event be regarded as a guarantee of conditions or characteristics. Bestirpower does not assume any liability for infringement of patents, copyrights, or other intellectual property rights of third parties by or arising from the use of Products or technical information described in this document.

This document is the property of Bestirpower Co., LTD., and not allowed to copy or transformed to other format if not under the authority approval.

© 2024 bestirpower – All rights Reserved