

Three Phase Solid State Relays

SIT865390
 24-520 VAC - 3 x 50A
 (AC-51 : 3 x 22 ARMS)
 (AC-53 : 3 x 12 ARMS)

- Solid State Relay for all type of loads with integrated heatsink
- DIN rail or panel mounting
- Back to back thyristors with TMS² technology
- 50A Thyristors size with $I^2t > 1500A^2s$ (*)
- 8,5-30 VDC or 10-30VAC control voltage with input status LED
- RC+ Overvoltage protection by integrated VDR
- IP20
- Designed in conformity with UL, EN60950 and IEC60947-4-3

(*) : on request : model with I^2t 5000A²s up to 20000A²s

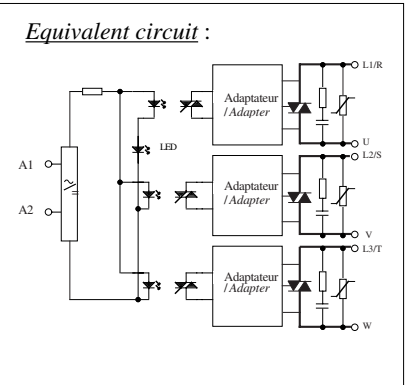
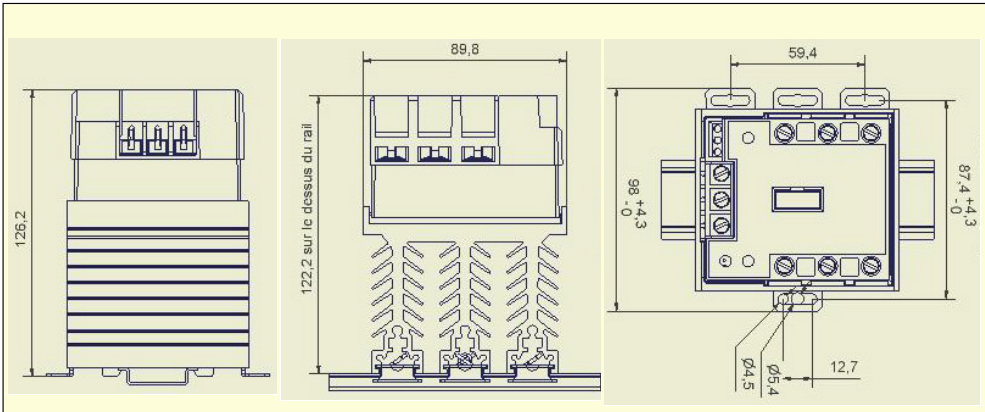

Caractéristiques de commande (à 20°C) / Control characteristics (at 20°C)

Paramètre / Parameter	Symbol	AC-DC			Unit
		Min	Nom	Max	
Tension de commande / Control voltage : DC	Uc	8,5	24	30	VDC
Tension de commande / Control voltage : AC	Uc	10	24	30	VAC
Courant de commande / Control current (@ Uc)	Ic	15	50	65	mA
Tension de relachement/Release voltage	Uc off	4			V
Résistance interne / Input internal resistor fig.1	Rc		410		Ω
Tension inverse / Reverse voltage	Urv	polarity free			V

Caractéristiques d'entrée-sortie (à 20°C) / Input-output characteristics (at 20°C)

Isolement entrée-sortie/Input-output isolation @500m	Ui	4000		VRMS
Isolement sortie-semelle/Output-case isolation @500m	Ui	3300		VRMS
Tension assignée isolement/ Rated impulse voltage	Uimp	4000		V

fig. 1 :Caractéristique d'entrée / Control characteristic

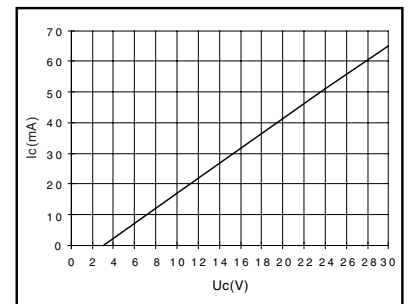

General characteristics

Parameter	Conditions	Symbol	Typ.	Unit
Poids/Weight			1000	g
Storage temperature range			-40 / +100	°C
Operating temperature range			-40 / +80	°C

Proud to serve you

All technical characteristics are subject to change without previous notice.
 Caractéristiques sujettes à modifications sans préavis.

Output characteristics (at 20°C)

Parameter	Conditions	Symbol	Value	Unit
Load voltage		Ue	400	V rms
Minimum Operating range		Uemin	24	V rms
Maximum Operating range	(480Vrms + 10%)	Uemax	520 (*)	V rms
Peak voltage		Up	1200 (*)	V
(*) Clamping voltage	by VDR	Uclamp	850	V
Synchronizing level		Usync	12	V
Latching voltage	Ie nom	Ua	10	V
AC-51 no permanent nominal current	(see Fig. 2)	Ie AC-51	3x50	A rms
AC-51 nominal current	(see Fig. 2)	Ie AC-51	3x22	A rms
AC-53 nominal current		Ie AC-53	3x12	A rms
Non repetitive overload current	tp=10ms (Fig. 3)	Itsm	550 (typ 720)	A
On state voltage drop	@ Ie nom	Vd	1,4	V
Off state leakage current	@Ue, 50Hz	Ilk	1	mA
Minimum load current		Ie min	5	mA
Turn on time	Uc nom DC ,f=50Hz	ton max	30	ms
Turn off time	Uc nom DC ,f=50Hz	toff max	30	ms
Operating frequency range		f	10-400	Hz
Off state dv/dt		dv/dt	500	V/μs
Maximum di/dt non repetitive		di/dt	50	A/μs
I2t (<10ms)		I2t	1500 (typ 2600)	A2s
Conducted immunity level in conformity with IEC 1000-4-4 (burst)	IEC 1000-4-4 (burst)		2kV criterion B	
Conducted immunity level in conformity with IEC 1000-4-5(schocks)	IEC 1000-4-5(schocks)		2kV criterion A	

thermal curves :

- curve 1 :**
with ventilation in the heatsink (> 1m/s)
- curve 2 :**
working in normal conditions with a small ventilation in the cabinet
- curve 3 :**
according with IEC60947-4-2 in a closed cabinet without any ventilation.

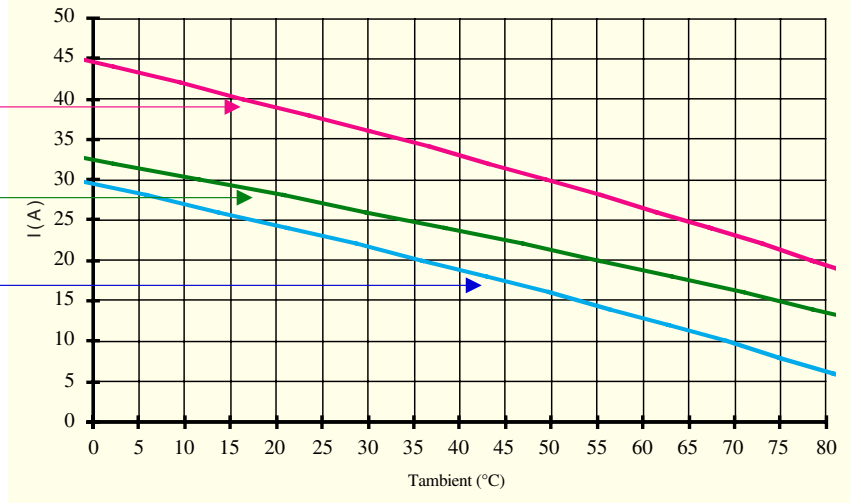
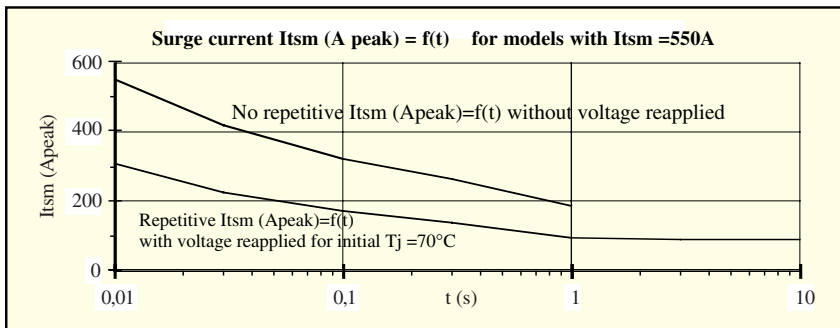

Fig.3 : Overload current curves



- 1 -No repetitive Itsm is given without voltage reapplied for the determination of the protection.
- 2 -Repetitive Itsm is given for inrush current with initial Tj = 70°C. The repetition of the surge current decrease the lifetime SSR's .





Cautions :



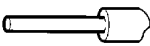

* Semiconductor relays don't provide any galvanic insulation between the load and the mains.

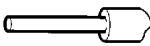
Proud to serve you

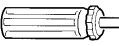
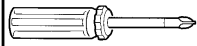

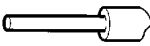
All technical characteristics are subject to change without previous notice.
Caractéristiques sujettes à modifications sans préavis.

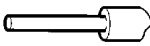
SVT						Wiring of the control circuit:	
NUMBER OF WIRES				SCREWDRIVER TYPE		MINIMUM TORQUE	
1		2					
SOLID (No ferrule)	FINE STRANDED (With ferrule)	SOLID (No ferrule)	FINE STRANDED (With ferrule)				
						N.m	
0,75 ... 2,5 mm ²	0,75 ... 2,5 mm ²	0,75 ... 2,5 mm ²	0,75 ... 2,5 mm ²	0,8 x 5,5 mm	POZIDRIV 2	1,2	

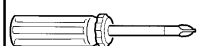
SVT						Wiring of the power circuit:	
NUMBER OF WIRES				SCREWDRIVER TYPE		MINIMUM TORQUE	
1		2					
SOLID (No ferrule)	FINE STRANDED (With ferrule)	SOLID (No ferrule)	FINE STRANDED (With ferrule)				
						N.m	
1,5 ... 10 mm ²	1,5 ... 6 mm ²	1,5 ... 10 mm ²	1,5 ... 6 mm ²	0,8 x 5,5 mm	POZIDRIV 2	1,8	

