

GENERAL DESCRIPTION

The LM2904DR consists of two independent, high gain and internally frequency compensated operational amplifiers, they are specifically designed to operate from a single power supply. Operation from split power supply is also possible and the low power and the low power supply current drain is independent of the magnitude of the power supply voltages. Typical applications include transducer amplifiers, DC gain blocks and most conventional operational amplifier circuits.

The LM2904DR is available in SOP-8 package.

FEATURES

- Internally Frequency Compensated for Unity Gain
- Large Voltage Gain: 100dB (Typical)
- Low Input Bias Current: 20nA (Typical)
- Low Input Offset Voltage: 2mV (Typical)
- Low Supply Current: 0.5mA (Typical)
- Wide Power Supply Voltage:
Single Supply: 3V to 36V
Dual Supplies: $\pm 1.5V$ to $\pm 18V$
- Input Common Mode Voltage Range Includes Ground
- Large Output Voltage Swing: 0V to $V_{CC} - 1.5V$
- Lead-Free Packages: SOP-8

Applications

- Battery Charger
- Cordless Telephone
- Switching Power Supply

Reference News

Type No	MARKING
LM2904DR	

Pin Assignments

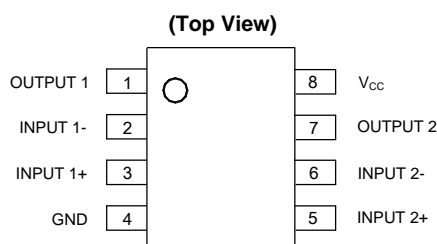

Typical Applications Circuit

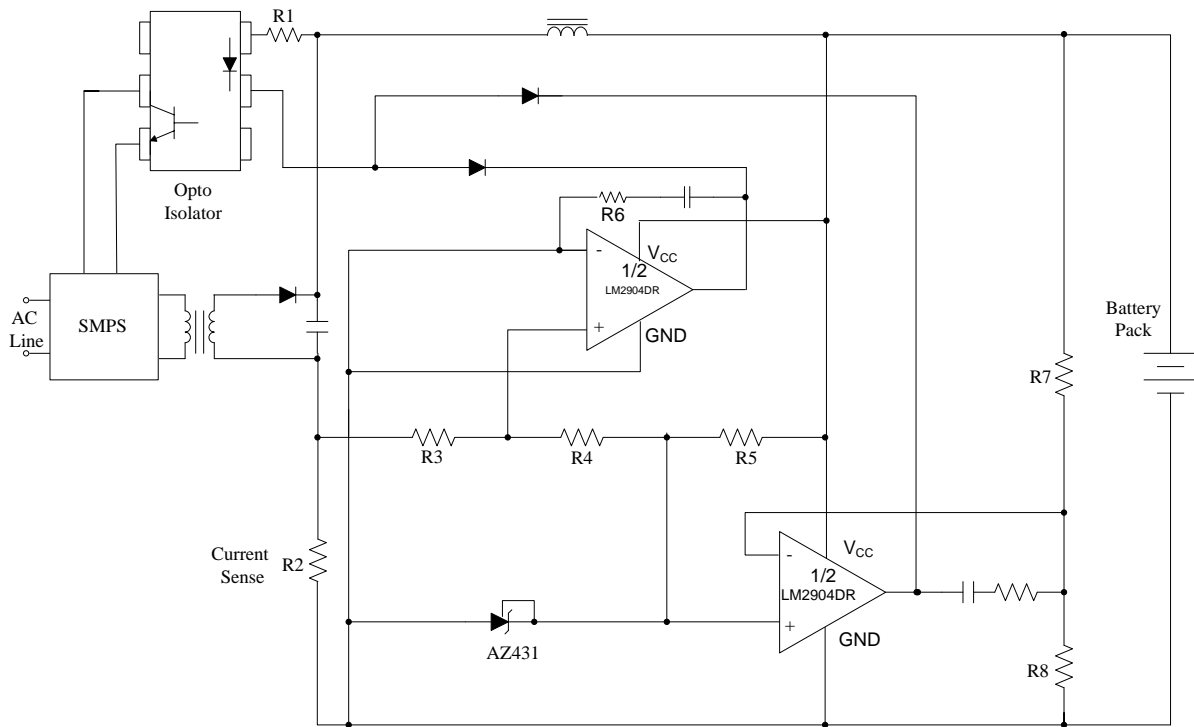

Battery Charger

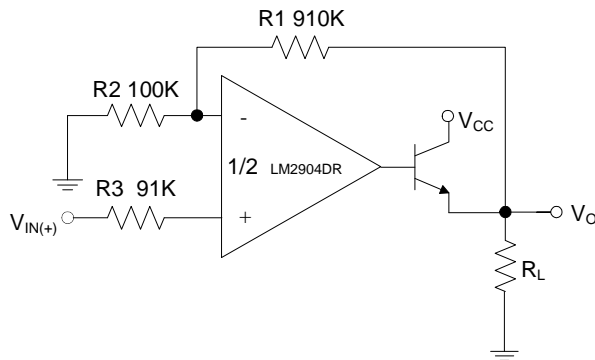

Power Amplifier

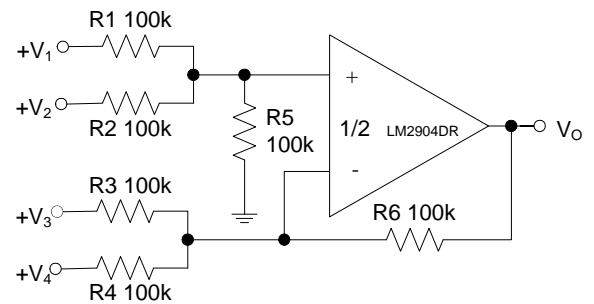

DC Summing Amplifier

Typical Applications Circuit (Cont.)

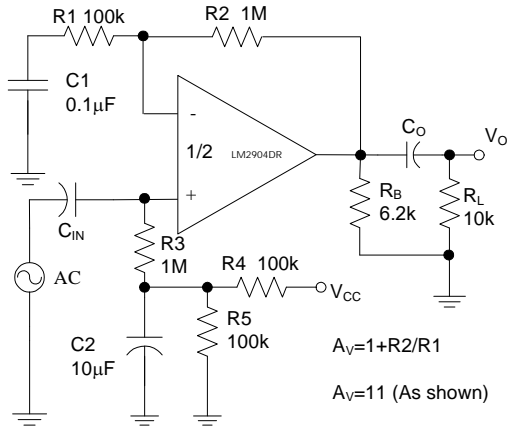

AC Coupled Non-Inverting Amplifier

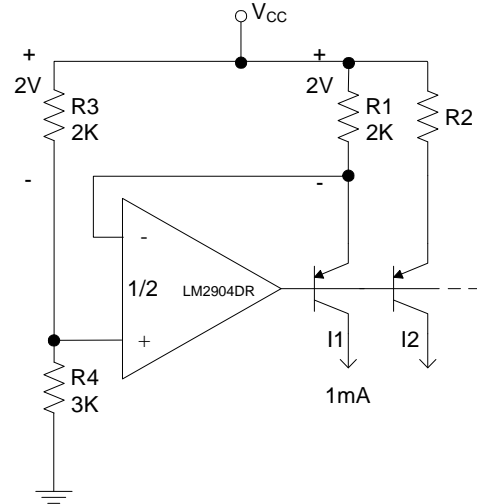

Fixed Current Sources

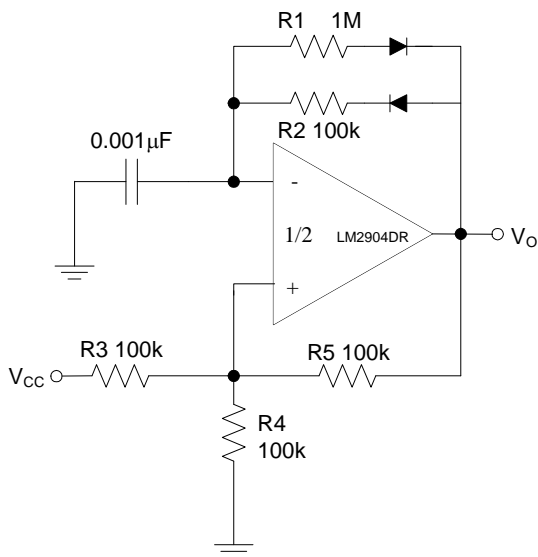

Pulse Generator

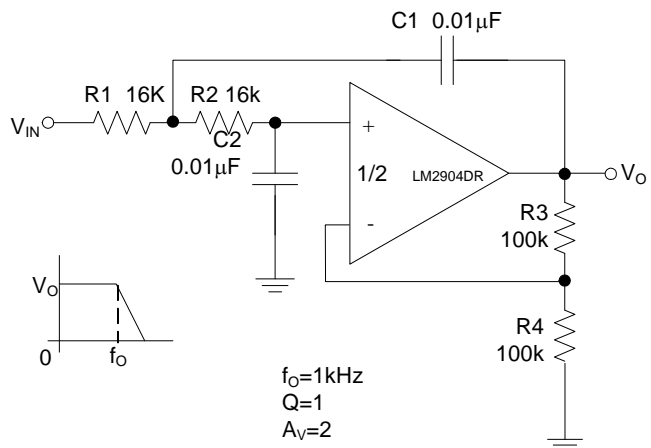

DC Coupled Low-Pass Active Filter

Functional Block Diagram

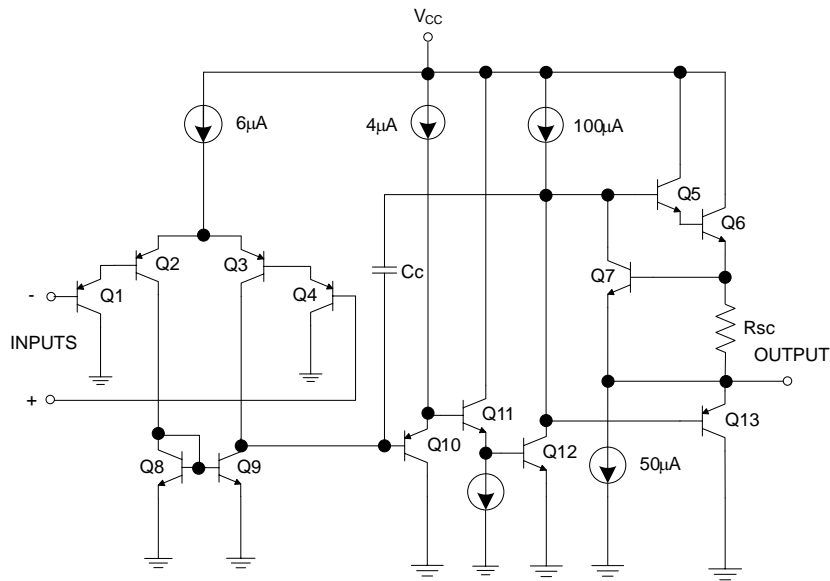

Absolute Maximum Ratings (Notes 1 & 2)

Symbol	Parameter	Rating	Unit
V _{CC}	Power Supply Voltage	40	V
V _{ID}	Differential Input Voltage	40	V
V _{IC}	Input Voltage	-0.3 to 40	V
P _D	Power Dissipation (T _A = +25°C)	550	mW
T _J	Operating Junction Temperature	+85	°C
T _{STG}	Storage Temperature Range	-65 to +150	°C
T _{LEAD}	Lead Temperature (Soldering, 10 Seconds)	+260	°C

- Notes:
1. Stresses greater than those listed under "Absolute Maximum Ratings" may cause permanent damage to the device. These are stress ratings only, and functional operation of the device at these or any other conditions beyond those indicated under "Recommended Operating Conditions" is not implied. Exposure to "Absolute Maximum Ratings" for extended periods may affect device reliability.
 2. ESD sensitivity.

Recommended Operating Conditions

Symbol	Parameter	Min	Max	Unit
V _{CC}	Supply Voltage	3	36	V
T _A	Ambient Operating Temperature Range	-40	+85	°C

Electrical Characteristics

(Limits in standard typeface are for $T_A = +25^\circ\text{C}$, bold typeface applies over -40°C to $+85^\circ\text{C}$ (Note 6), $V_{CC} = 5\text{V}$, $\text{GND} = 0\text{V}$, unless otherwise specified.)

Symbol	Parameter		Conditions	Min	Typ	Max	Unit
V_{IO}	Input Offset Voltage		$V_O = 1.4\text{V}$, $R_S = 0\Omega$, $V_{CC} = 5\text{V}$ to 30V	—	2	5	mV
				—	—	7	
$\Delta V_{IO}/\Delta T$	Average Temperature Coefficient of Input Offset Voltage		$T_A = -40^\circ\text{C}$ to $+85^\circ\text{C}$	—	7	—	$\mu\text{V}/^\circ\text{C}$
I_{BIAS}	Input Bias Current		I_{IN+} or I_{IN-} , $V_{CM} = 0\text{V}$	—	20	200	nA
				—	—	200	
I_{IO}	Input Offset Current		$I_{IN+} - I_{IN-}$, $V_{CM} = 0\text{V}$	—	5	30	nA
				—	—	100	
V_{IR}	Input Common Mode Voltage Range (Note 2)		$V_{CC} = 30\text{V}$	0	—	$V_{CC} - 1.5$	V
I_{CC}	Supply Current		$T_A = -40^\circ\text{C}$ to $+85^\circ\text{C}$, $R_L = \infty$, $V_{CC} = 30\text{V}$	—	0.7	2	mA
			$T_A = -40^\circ\text{C}$ to $+85^\circ\text{C}$, $R_L = \infty$, $V_{CC} = 5\text{V}$	—	0.5	1.2	
G_V	Large Signal Voltage Gain		$V_{CC} = 15\text{V}$, $V_O = 1\text{V}$ to 11V , $R_L \geq 2\text{k}\Omega$	85	100	—	dB
				80	—	—	
CMRR	Common Mode Rejection Ratio		DC, $V_{CM} = 0\text{V}$ to $(V_{CC}-1.5)\text{V}$	60	70	—	dB
				60	—	—	
PSRR	Power Supply Rejection Ratio		$V_{CC} = 5\text{V}$ to 30V	70	100	—	dB
				60	—	—	
CS	Channel Separation		$f = 1\text{kHz}$ to 20kHz	—	-120	—	dB
I_{SOURCE}	Output Current	Source	$V_{IN+} = 1\text{V}$, $V_{IN-} = 0\text{V}$, $V_{CC} = 15\text{V}$, $V_O = 2\text{V}$	20	40	—	mA
		Sink	$V_{IN+} = 0\text{V}$, $V_{IN-} = 1\text{V}$, $V_{CC} = 15\text{V}$, $V_O = 2\text{V}$	10	15	—	
I_{SINK}	Output Current	Sink	$V_{IN+} = 0\text{V}$, $V_{IN-} = 1\text{V}$, $V_{CC} = 15\text{V}$, $V_O = 2\text{V}$	5	—	—	mA
			$V_{IN+} = 0\text{V}$, $V_{IN-} = 1\text{V}$, $V_{CC} = 15\text{V}$, $V_O = 0.2\text{V}$	12	50	—	
I_{SC}	Output Short Circuit Current to Ground		$V_{CC} = 15\text{V}$	—	40	60	mA
V_{OH}	Output Voltage Swing		$V_{CC} = 30\text{V}$, $R_L = 2\text{k}\Omega$	26	—	—	V
				26	—	—	
V_{OL}	Output Voltage Swing		$V_{CC} = 30\text{V}$, $R_L = 10\text{k}\Omega$	27	28	—	mV
				27	—	—	
θ_{JC}	Thermal Resistance (Junction to Case)		$V_{CC} = 5\text{V}$, $R_L = 10\text{k}\Omega$	—	5	20	$^\circ\text{C}/\text{W}$
				—	—	30	
θ_{JA}	Thermal Resistance (Junction to Ambient)			—	17	—	$^\circ\text{C}/\text{W}$
				—	115	—	

Notes: 1. Limits over the full temperature are guaranteed by design, but not tested in production.

2. The input common-mode voltage of either input signal voltage should not be allowed to go negatively by more than 0.3V (at $+25^\circ\text{C}$). The upper end of the common-mode voltage range is $V_{CC}-1.5\text{V}$ (at $+25^\circ\text{C}$), but either or both inputs can go to $+36\text{V}$ without damages, independent of the magnitude of the V_{CC} .

Performance Characteristics

Input Voltage Range

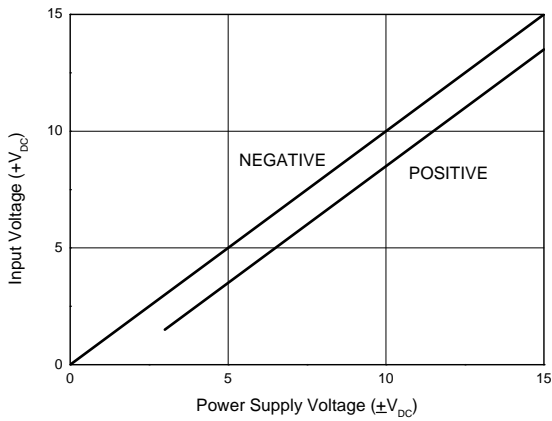

Input Current

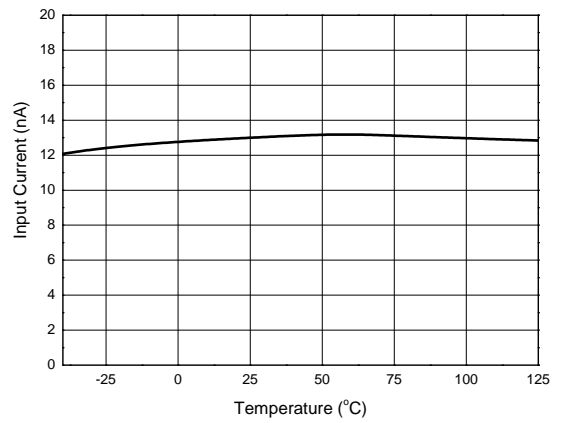

Supply Current

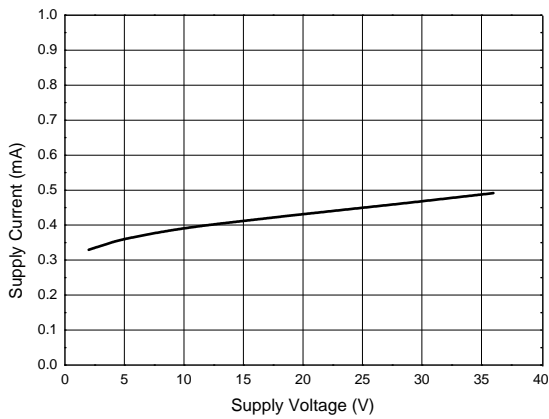

Voltage Gain

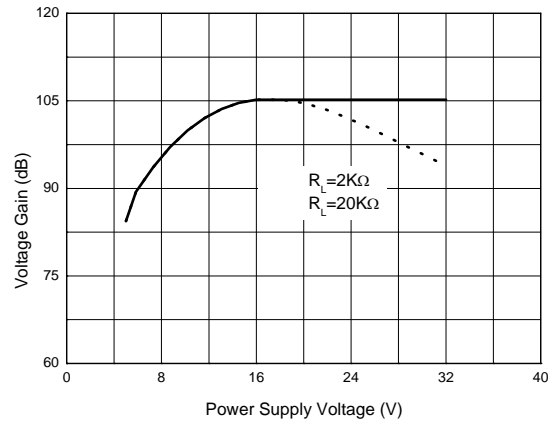

Open Loop Frequency Response

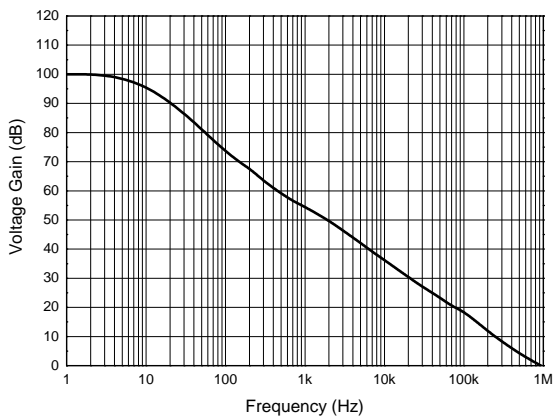

Voltage Follower Pulse Response

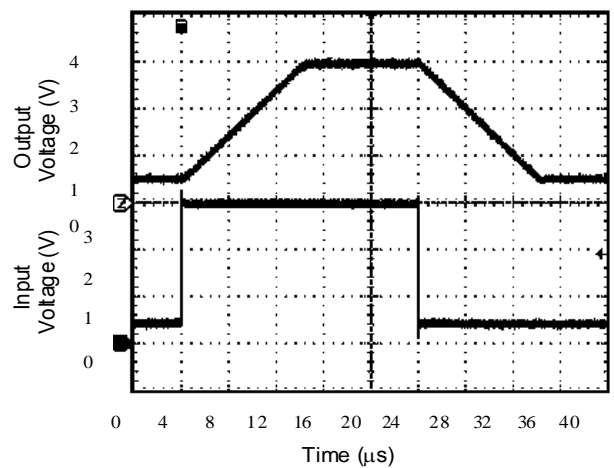

Performance Characteristics (Cont.)

Voltage Follower Pulse Response (Small Signal)

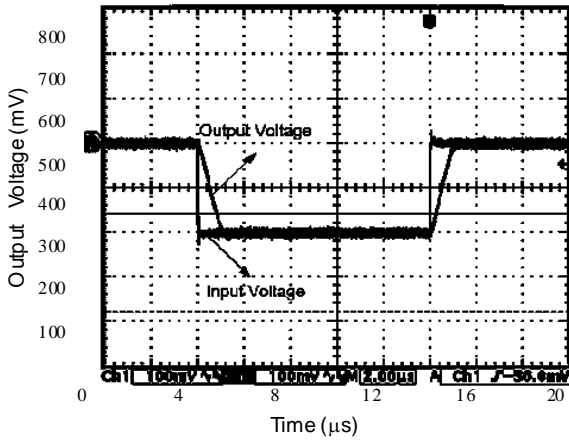

Large Signal Frequency Response

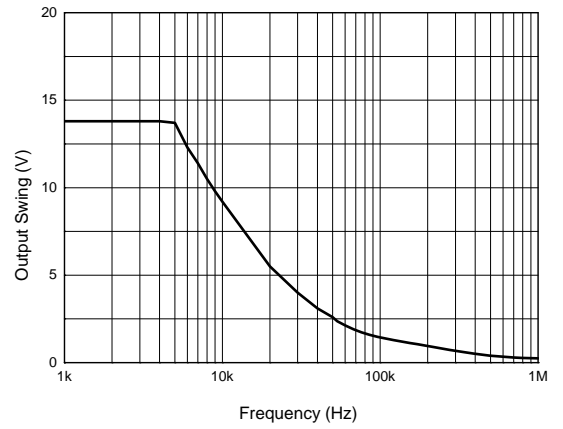

Output Characteristics: Current Sourcing

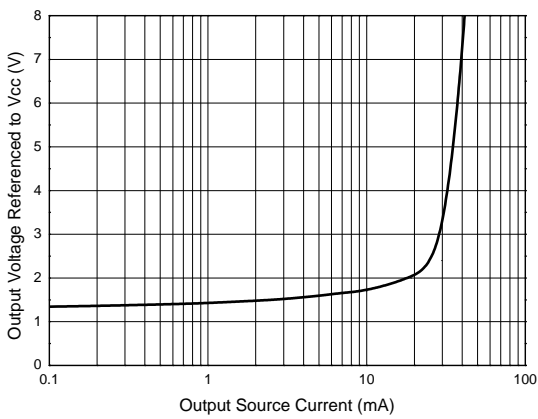

Output Characteristics: Current Sinking

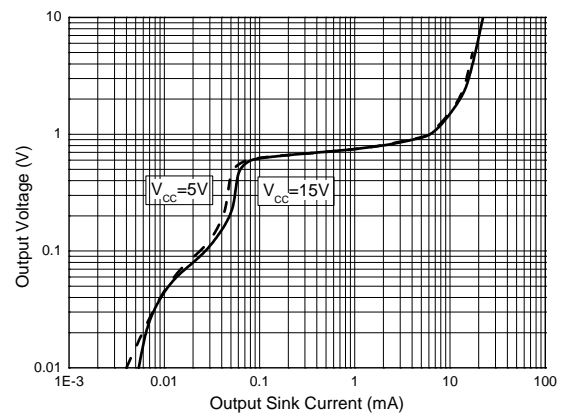

Current Limiting

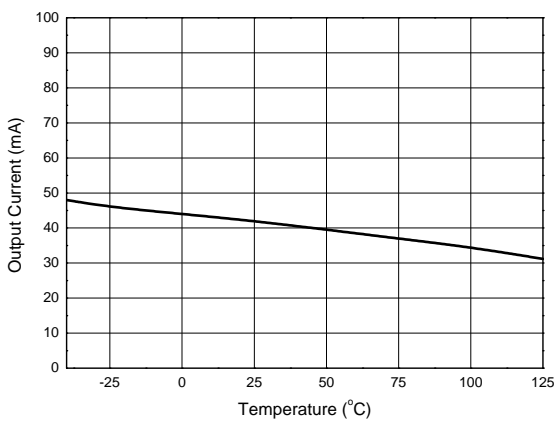

Physical Dimensions

SOP-8

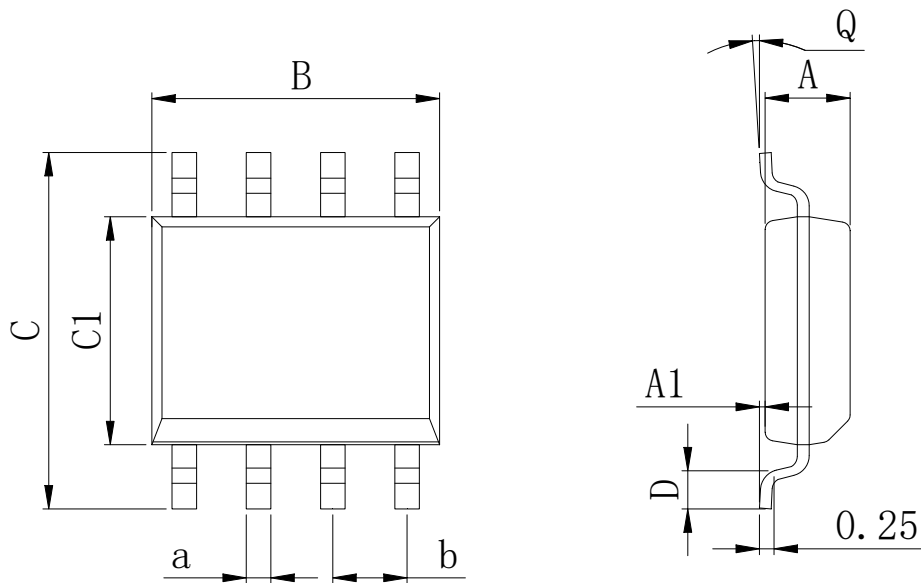

Dimensions In Millimeters(SOP-8)									
Symbol:	A	A1	B	C	C1	D	Q	a	b
Min:	1.35	0.05	4.90	5.80	3.80	0.40	0°	0.35	1.27 BSC
Max:	1.55	0.20	5.10	⁹ 6.20	4.00	0.80	8°	0.45	

ORDER INFORMATION

P/N	PKG	QTY
LM2904DR	SOP-8	2500