

PCA2V3223

Automotive power-over-coax inductors for decoupling circuits



Product features

- AEC-Q200
- High reliability
- Ferrite core wire wound construction
- 1210 (3225 metric) package in 2.5 mm height
- Weight: 0.079 grams typical
- Moisture sensitivity level (MSL): 1

Applications

- ADAS camera
- SRR (Short range radar)
- LiDAR (Light detection and ranging)
- Vehicle communications
- Autonomous driving (3D mapping)
- Transmitting signal and power over single cable
- Decoupling circuits

Environmental compliance and general specifications

- Operating temperature range: -55 °C to +150 °C (ambient plus self-temperature rise)
- Storage temperature (component): -55 °C to +150 °C



Product specifications

Part number ¹	OCL ¹ (μH)	DCR (Ω) maximum @ +25 °C	I _{sat} ² (mA) typical			I _{rms} ³ (mA) typical		
			+25 °C	+105 °C	+125 °C	+25 °C	+105 °C	+125 °C
PCA2V3223-2R2-R	2.2±20%	0.18	1100	1000	950	1350	1220	1045
PCA2V3223-4R7-R	4.7±20%	0.10	720	650	600	1500	1400	1300
PCA2V3223-100-R	10±20%	0.15	450	400	350	1300	1200	1100
PCA2V3223-150-R	15±20%	0.40	400	350	310	825	725	625

1. Open Circuit Inductance (OCL): Test frequency parameters: 100 kHz, 0.1 V @ 25 °C

2. I_{sat}: DC current that causes ≤ 30% inductance drop from its initial value.

3. I_{rms}: Rated current that will cause an approximate temperature rise of 40 °C. The part temperature (ambient + temp rise) should not exceed +150 °C

4. Part number definition: PCA2V3223-xxx-R

PCA2V3223= Product code and size

xxx= inductance value in μH, R= decimal point, if no R is present

then last character equals number of zeros

-R suffix = RoHS compliant

Mechanical parameters (mm)

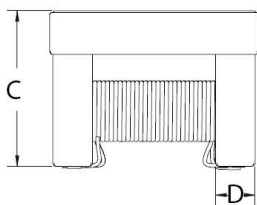
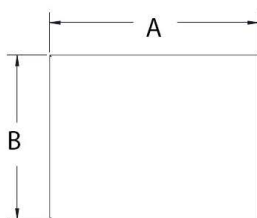

Recommended pad layout

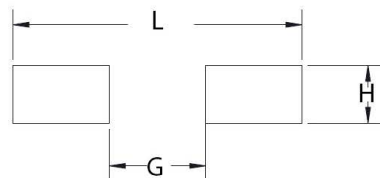

Schematic

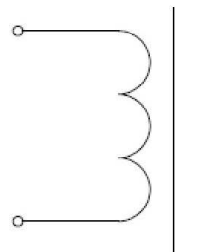

Part number	A	B	C	D	L	G	H
PCA2V3223-XXX-R	3.20 ± 0.20	2.50 ± 0.20	2.30 ± 0.20	0.58 ± 0.10	3.80 ref	2.20 ref	2.80 ref

Part marking: No marking

All soldering surfaces to be coplanar within 0.1 millimeters

Pad layout dimensions are reference only

Traces or vias underneath the inductor is not recommended

Packaging information (mm)

Drawing not to scale

Supplied in tape and reel packaging, 1500 parts per 7" diameter reel (EIA-481 compliant)

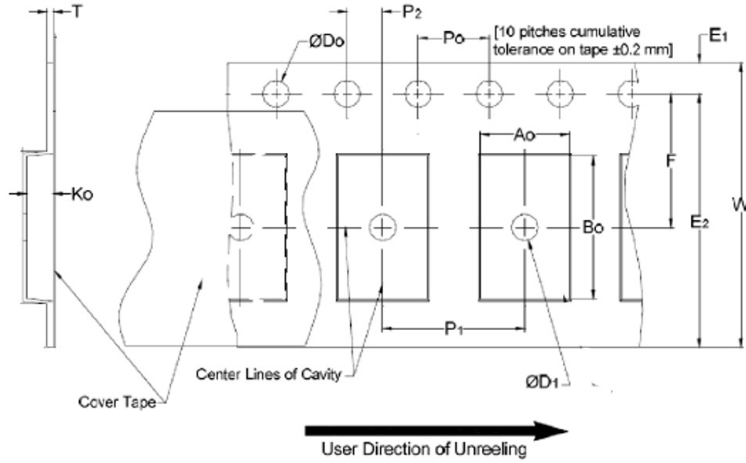

Ao	2.7 ± 0.1
Bo	3.5 ± 0.1
Ko	2.75 ± 0.1
T	0.3 ± 0.05
W	8 ± 0.1
F	3.5 ± 0.05
E1	1.75 ± 0.1
E2	N/A
P0	4 ± 0.1
P1	4 ± 0.1
P2	2 ± 0.05
D0	1.5 + 0.1/-0
D1	1 ± 0.1

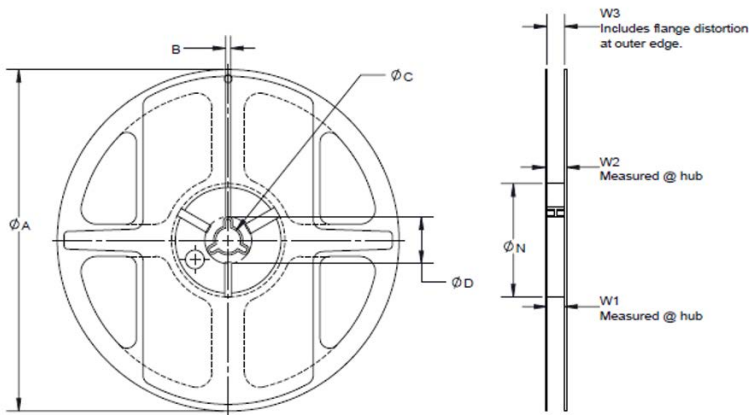

Shape & Appearance For Reference Only

Type	7" * 8
A	178 ± 2
B	2 ± 0.5
C	13.5 ± 0.5
D	21
N	60 ± 2
W1	9 ± 0.5
W2	N/A
W3	N/A

Impedance vs frequency

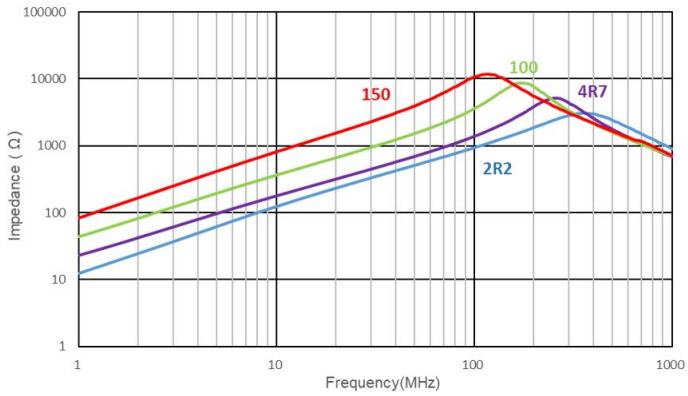

Inductance vs DC current

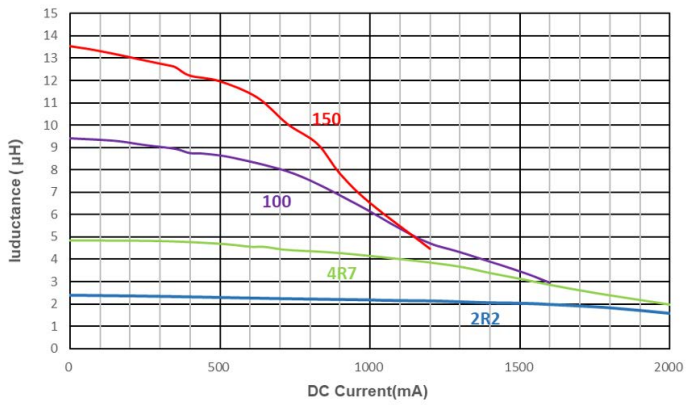

Solder reflow profile

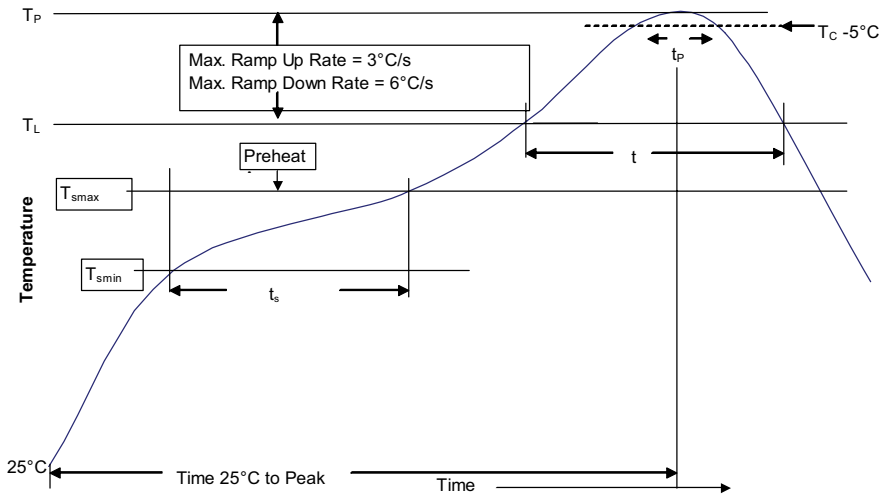

Table 1 - Standard SnPb solder (T_c)

Package thickness	Volume mm ³ <350	Volume mm ³ ≥350
<2.5 mm	235 °C	220 °C
≥2.5 mm	220 °C	220 °C

Table 2 - Lead (Pb) free solder (T_c)

Package thickness	Volume mm ³ <350	Volume mm ³ 350 - 2000	Volume mm ³ >2000
<1.6 mm	260 °C	260 °C	260 °C
1.6 – 2.5 mm	260 °C	250 °C	245 °C
>2.5 mm	250 °C	245 °C	245 °C

Reference J-STD-020

Profile feature	Standard SnPb solder	Lead (Pb) free solder
Preheat and soak		
• Temperature min. (T_{smin})	100 °C	150 °C
• Temperature max. (T_{smax})	150 °C	200 °C
• Time (T_{smin} to T_{smax}) (t_s)	60-120 seconds	60-120 seconds
Ramp up rate T_L to T_p	3 °C/ second max.	3 °C/ second max.
Liquidous temperature (T_L)	183 °C	217 °C
Time (t_L) maintained above T_L	60-150 seconds	60-150 seconds
Peak package body temperature (T_p)*	Table 1	Table 2
Time (t_p)* within 5 °C of the specified classification temperature (T_c)	20 seconds*	30 seconds*
Ramp-down rate (T_p to T_L)	6 °C/ second max.	6 °C/ second max.
Time 25 °C to peak temperature	6 minutes max.	8 minutes max.

* Tolerance for peak profile temperature (T_p) is defined as a supplier minimum and a user maximum.

Life Support Policy: Eaton does not authorize the use of any of its products for use in life support devices or systems without the express written approval of an officer of the Company. Life support systems are devices which support or sustain life, and whose failure to perform, when properly used in accordance with instructions for use provided in the labeling, can be reasonably expected to result in significant injury to the user.

Eaton reserves the right, without notice, to change design or construction of any products and to discontinue or limit distribution of any products. Eaton also reserves the right to change or update, without notice, any technical information contained in this bulletin.

Eaton
Electronics Division
1000 Eaton Boulevard
Cleveland, OH 44122
United States
Eaton.com/electronics

© 2023 Eaton
All Rights Reserved
Printed in USA
Publication No. ELX1351 BU-ELX22217
June 2023

Eaton is a registered trademark.
All other trademarks are property of their respective owners.

Follow us on social media to get the latest product and support information.

