

## Application



The general purpose ultrasonic level transmitter provides continuous level measurement up to 49.2" (1.25m) with a 4-20 mA signal output, and is configured via our free Webcal software. The embedded level controller can lower cost by replacing external control hardware. This non-contact liquid level sensor is ideally suited for corrosive, sticky or dirty liquids, and is widely selected for small day tank, skid, IBC, sump and process tank level applications.



## Features

- ✓ Level detection, switch and control functions up to 49.2" (1.25m)
- ✓ Configuration is fast and easy via WebCal software and USB adapter
- ✓ Narrow 2" beam width and short 2" dead band optimized for small tanks
- ✓ Four (4) programmable relays rated @ 1A / 60VA for switch, pump or valve control and fail-safety
  - 1 pump or valve with 3 alarms
  - 2 pumps (lead-lag) with 2 alarms
  - 2 pumps (duplexing) with 2 alarms
  - 4 independent switch point alarms
- ✓ PVDF transducer and 6P polycarbonate enclosure for corrosive liquids
- ✓ Automatic temperature compensation for accurate measurement

## Success



EchoPod is featured in what FOX News calls, "The greenest house in the world". Florida's Green House spotlights residential conservation technologies for EPA, university, engineer and architect study. As the nations water resources

further decline, reclamation is core to the solution. The average US citizen consumes 88 gallons of water per day. About 65% of indoor use occurs in the bathroom and 1/3 of that flushes down the toilet. Reclamation systems collect and filter grey water from sinks, showers, baths, laundry and the yard for reuse in flushing toilets and irrigation. The system includes a 30-120 gallon underground water cistern. Each tank is plumbed with an overflow drain, freshwater inlet, fill valve, recirculating pump and level control. EchoPod measures the level, and when necessary, opens the fill valve to ensure that water is available to the system.

## Compatible Products

**DataLoop™**  
Level Indicator



LI25

**DataView™**  
Level Controller



LI55

**Commander™**  
Multi-Tank Level Controller



LI90

**DataPoint™**  
Level Controller



LC52

### Specifications

**Range:** 49.2" (1.25m)  
**Accuracy:** 0.125" (3mm)  
**Resolution:** 0.019" (0.5mm)  
**Dead band:** 2" (5cm)  
**Beam width:** 2" (5cm)  
**Configuration:** WebCal® PC  
 Windows® USB 2.0  
**Memory:** Non-volatile  
**Supply voltage:** 24 VDC (loop)  
**Consumption:** 0.5W  
**Loop resist.:** 400Ω max  
**Signal output:** 4-20 mA, two-wire  
**Signal invert:** 4-20 mA or 20-4 mA  
**Signal fail-safe:** 4 mA, 20 mA, 21 mA, 22 mA or hold last  
**Contact type:** (4) SPST relays, 1A  
**Contact fail-safe:** Power loss: Hold last  
 Power on: Open, close or hold last  
**Hysteresis:** Selectable  
**Process temp.:** F: 20° to 140°  
 C: -7° to 60°  
**Temp. comp.:** Automatic  
**Ambient temp.:** F: -31° to 140°  
 C: -35° to 60°  
**Pressure:** MWP = 30 PSI (2 bar)  
**Enclosure rating:** Type 6P, encapsulated, corrosion resistant & submersible  
**Encl. material:** Polycarbonate  
**Strain relief mat.:** Santoprene  
**Trans. material:** PVDF  
**Cable jacket mat.:** Polyurethane  
**Cable type:** 9-conductor, shielded  
**Cable length:** 48" (1.2m)  
**Process mount:** 1" NPT (1" G)  
**Mount gasket:** Viton®  
**Classification:** General purpose  
**Compliance:** CE, RoHS  
**Approvals:** cFMus

### Dimensions

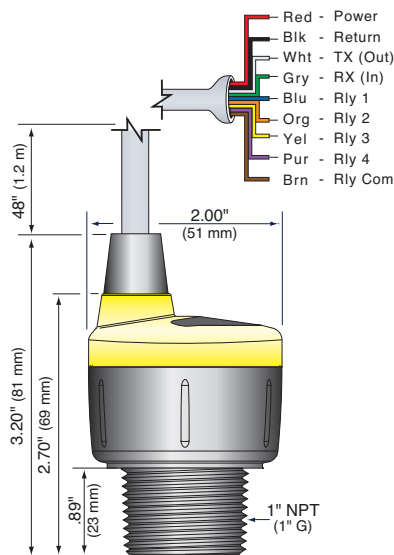

### Configuration



The level sensor is configurable via our free WebCal PC software and Fob USB adapter. The sensors are offered with and without Fobs. Fobs are universal and can be used to configure any WebCal compatible product.

Download your free copy of WebCal in English or Chinese at [www.flowline.com/webcal.php](http://www.flowline.com/webcal.php).

### Fittings

For optimum performance, install the level sensor using the below recommended or direct equivalent fittings.

	P/N	Description
	LM52-1400	2" NPT x 1" NPT (Sch. 40)
	LM52-1800	2" NPT x 1" NPT (Sch. 80)
	LM52-1410	2" Socket x 1" NPT (Sch. 40)
	LM52-1810	2" Socket x 1" NPT (Sch. 80)
	LM52-1850	1" NPT Flange - 150# (Sch. 80)
	LM50-1001-1	1" NPT Bracket, Polypropylene

### Ordering

DL14-

**Process mount (1)**

- 0 NPT (US)
- 1 G (Metric)

**Fob USB interface (2)**

- 0 Without Fob
- 1 With Fob

#### Notes

- 1) Install the level sensor using Flowline installation fittings or equivalents.
- 2) The level sensor is configured via our WebCal software and one LI99-1001 Fob USB adapter. The level sensor is offered with and without a Fob. Fobs are universal and can be used to configure any WebCal compatible product. WebCal is a free download from our website at [www.flowline.com/webcal.php](http://www.flowline.com/webcal.php).