

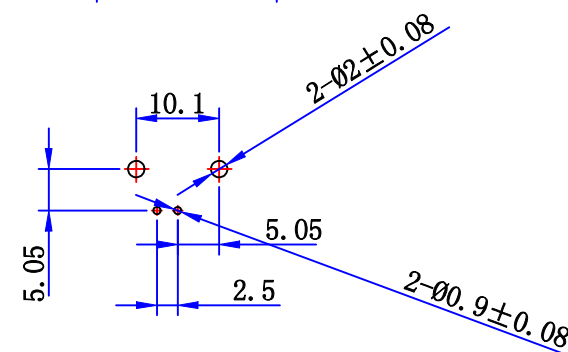

Product NO.		DOSIN-801-0035		
REV	DESCRIPTION	DWN	DATE	APPROVEN
A	First issue	CHEN	2016/2/25	John kine

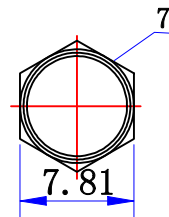
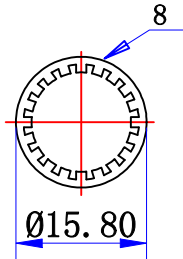
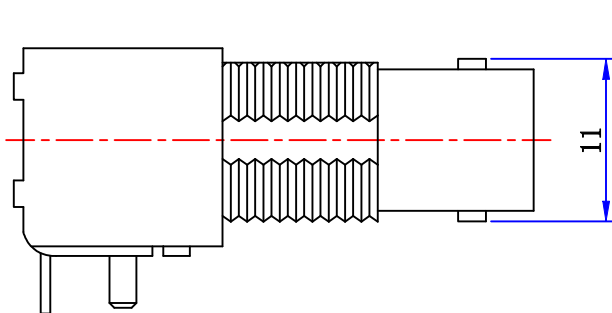
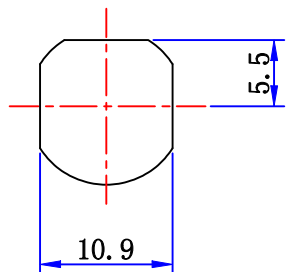
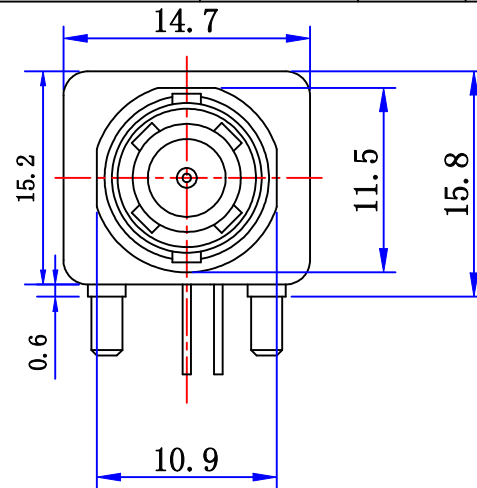
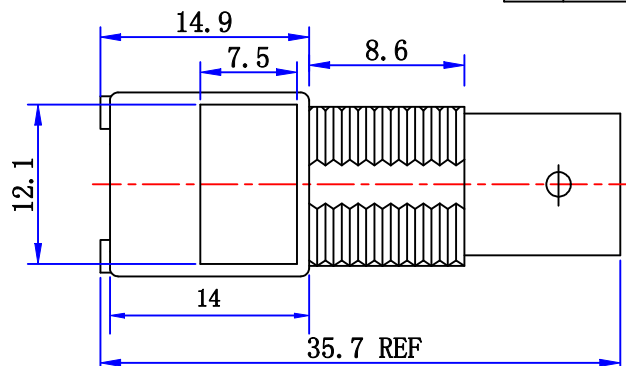
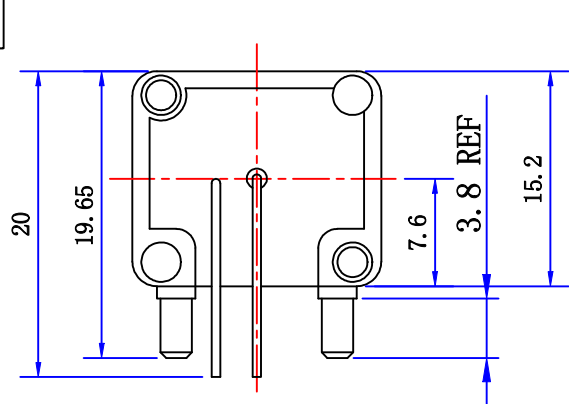

Specifications

Impedance: 75 Ohms
 Frequency Range: DC~3G
 VSWR: 1.3MAX
 Working Voltage: 500V rms @ sea level
 Insulation Resistance: 5000 Ohms min
 Temperature Range: -55°C TO +155°C
 Relative Temperature: ≤95% (40°C ±2°C)
 Drawings products are in line with ROHS standards

PCB HOLE CONFIGURATION
RECOMMENDED PANEL CUTOUTS

NOTE:

NO	DESCRIPTION	MATERIAL	FINISHED	QTY
E	LOCK WASHER	BRASS	NICKEL	1
D	HEX NUT	BRASS	NICKEL	1
C	INSULATOR	POM	NONE	1
B	CONTACT	BRASS	GOLD	1
A	BODY	ZINC	NICKEL	1

DRAWN	2016/2/25
Zelin. CHEN	
CHECKED	
APPROVALS	29.2.2016
John Kine	

Tolerance	0-6 ±0.15 6-30 ±0.20 30-120 ±0.5 Angular ±2°
View	
UNIT	MM
SCALE	1:1

Dosin Industrial(H.K)Co.Ltd 东莞市德索五金电子制品有限公司 Dosin Hardware Electronics Co.,Ltd		E-mail: dosin2005@163.com dosin2005@dosin-china.com Web: http://www.dosinconn.com TEL: (0086) 769-81153906 FAX: (0086) 769-81875836	
Name: BNC CONNECTOR DNN			
SIZE A	Product NO.	REV B	
	DOSIN-801-0035		
DateTime	CAD FILE	SHEET: 1 OF 1	
2016/2/25	D/company drawings/BD		