

THIS DOCUMENT IS THE PROPERTY OF KEYSTONE ELECTRONICS CORP. AND SHALL NOT BE REPRODUCED, DISTRIBUTED OR USED AS A BASIS FOR MANUFACTURE WITHOUT PRIOR WRITTEN PERMISSION FROM KEYSTONE ELECTRONICS CORP.

ACTUAL SIZE

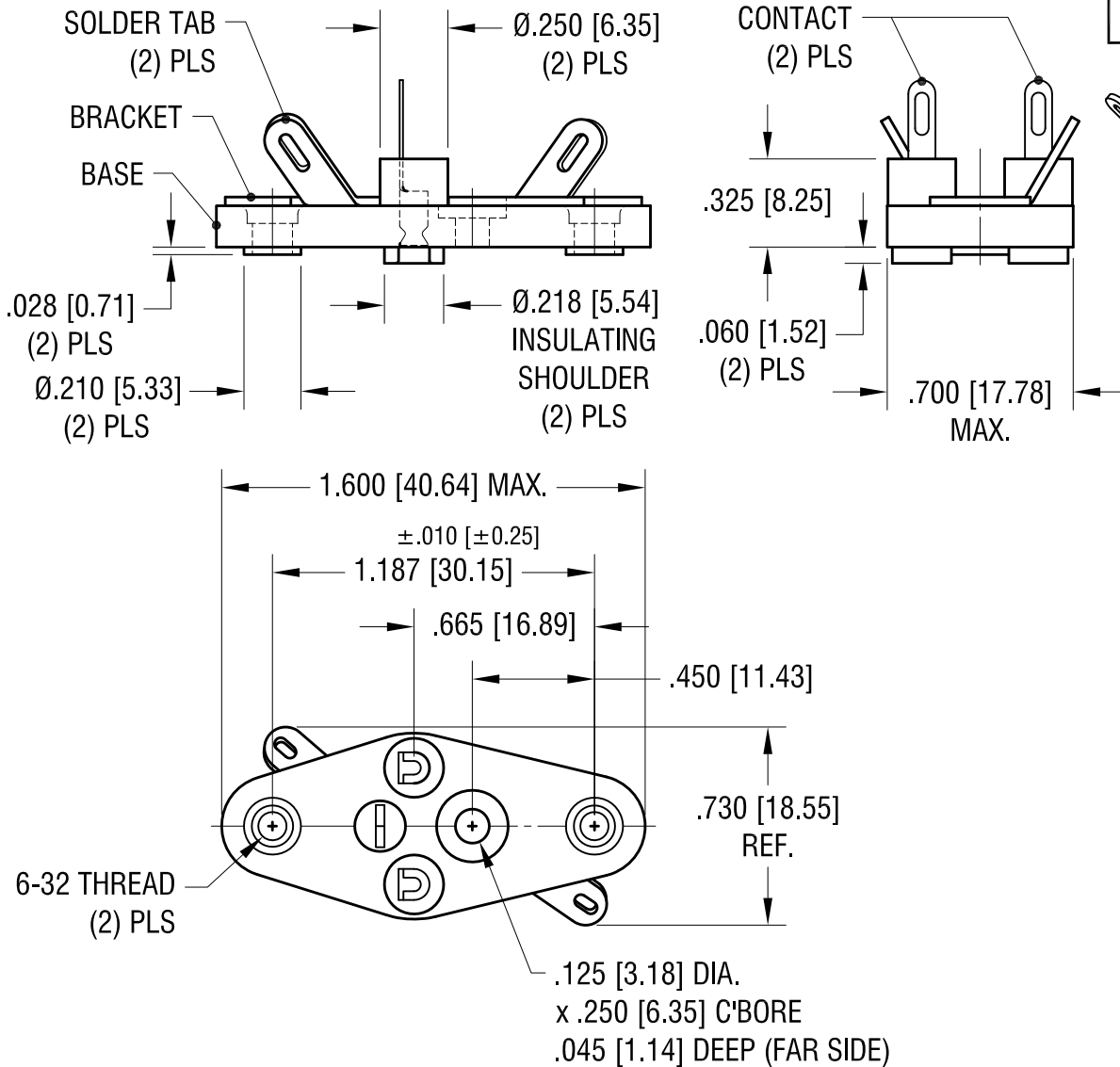

NOTES:

- 1. BASE, INSULATING:
MAT'L - PBT (BLACK COLOR) UL 94V-0
- 2. BRACKET, MOUNTING:
MAT'L - .032 [0.81] TH'K BRASS
FINISH - TIN PLATE

- 3. CONTACT:
MAT'L - .012 [0.30] TH'K BRASS
FINISH - TIN PLATE
- 4. PART SUPPLIED ON TRAY
10.24 [260.0] x 9.84 [250.0] x .788 [20.0] TRAY
50 PIECES PER TRAY - 450 PIECES PER BOX

DATE	DESCRIPTION	REV.
12.05.23	ADD PACKAGING CHANGE AS PER ECN23-304	C
3.23.15	BASE MAT'L WAS POLYESTER CHANGE AS PER ECN15-034	B
5.18.04	CHANGE AS PER ECN 04-038	A

KEYSTONE ELECTRONICS CORP.			
www.keyelco.com • NEW HYDE PARK NY 11040 • Tel (516)328-7500			
PART NAME TO-3 DUAL TAB TRANSISTOR SOCKET			
MATERIAL AS NOTED			
FINISH AS NOTED		DRN BY BOONE	DATE 10.08.82
		APP'D RH	SCALE 1.5X
TOLERANCES	INCH [MM]	CODE	DWG NO.
DECIMAL	± .005 [± 0.13]	C	4514
ANGULAR	± 1°		
UNLESS OTHERWISE SPECIFIED			