

REVISIONS			
REV	DESCRIPTION	DATE	APPV
A	INITIAL RELEASE OF INTERNAL DOCUMENT	2-FEB-12	SAH
B	ADDED PART NUMBER TABLE AND SECOND SHEET; UPDATED NOTE 3	23-JUL-18	CLL

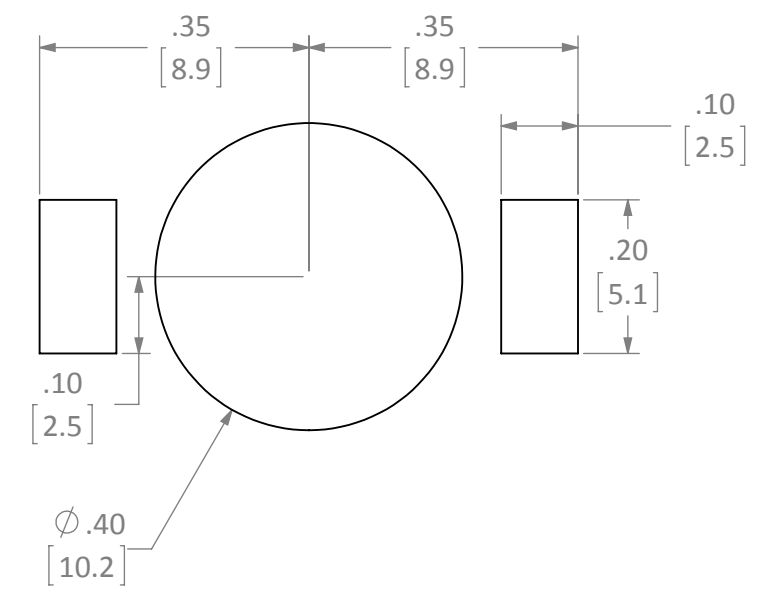

RECOMMENDED FOOTPRINT

- NOTES: (UNLESS OTHERWISE SPECIFIED)
1. ALL DIMENSIONS ARE IN INCHES [mm].
 2. DIMENSIONS APPLY AFTER FINISHING.
 3. MANUFACTURE TO BE COMPLIANT WITH EU RoHS DIRECTIVE, USE MATERIALS THAT DO NOT CONTAIN REACH SUBSTANCES OF VERY HIGH CONCERN >1000ppm, AND USE DRC CONFLICT-FREE SOURCED MATERIALS.
 4. SAFETY BREAK ALL SHARP CORNERS AND EDGES .02 MAXIMUM.

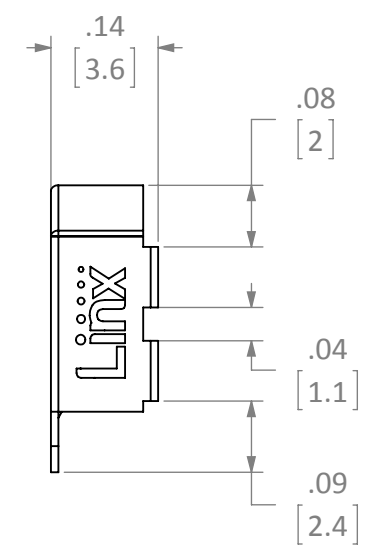
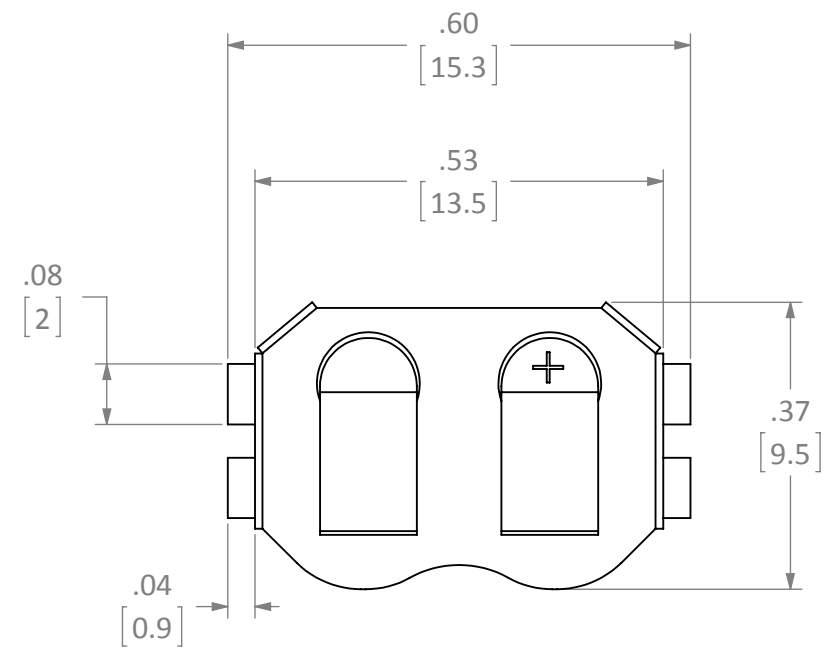
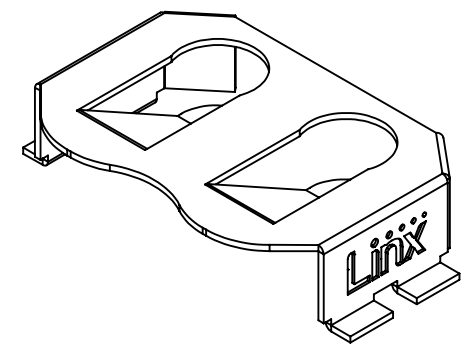

PART NUMBER	PACKAGING
BAT-HLD-012-SMT	BULK
BAT-HLD-012-SMT-TR	TAPE & REEL

<p>WARNING: THIS DRAWING CONTAINS PROPRIETARY INFORMATION THAT IS THE SOLE PROPERTY OF LINX TECHNOLOGIES, AND SHALL BE TREATED AS SUCH. NO DISCLOSURE OR REPRODUCTION OF THIS DOCUMENT IS PERMITTED, IN WHOLE OR IN PART, WITHOUT THE EXPRESS WRITTEN PERMISSION OF LINX TECHNOLOGIES OR ITS DESIGNATED AGENTS.</p>			
<p>MATERIAL: INTERPRET DIMENSIONS AND TOLERANCES PER ASME Y14.5.</p>		<p>PROJECTION: </p>	
<p>FINISH: SURFACE FINISH: $\sqrt{32}$ ANGLES: $\pm 1^\circ$</p>		<p>SIZE DWG. NO. REV</p>	
<p>TOLERANCES: .X $\pm .1$.XX $\pm .01$.XXX $\pm .005$</p>		<p>B BAT-HLD-012-SMT-OTL B</p>	
<p>DRAWN: B.MURPHY DT: 2-FEB-12</p>		<p>SCALE: 4:1 DO NOT SCALE DRAWING SHEET 1 OF 2</p>	
<p>ENGR: S.HOGAN DT: 2-FEB-12</p>		<p>LDCDFB_C</p>	

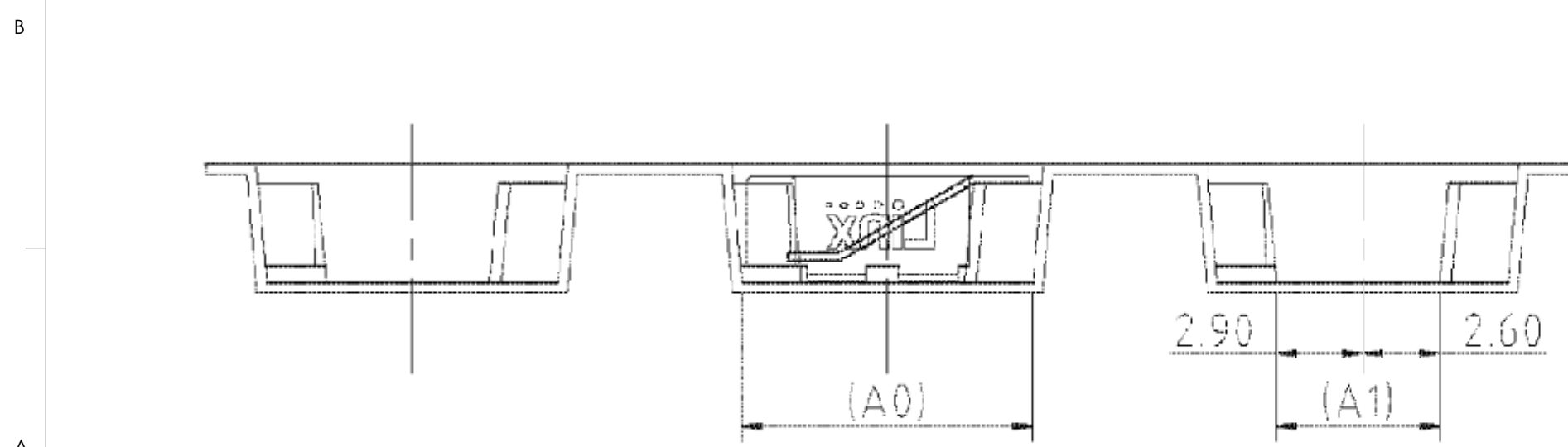
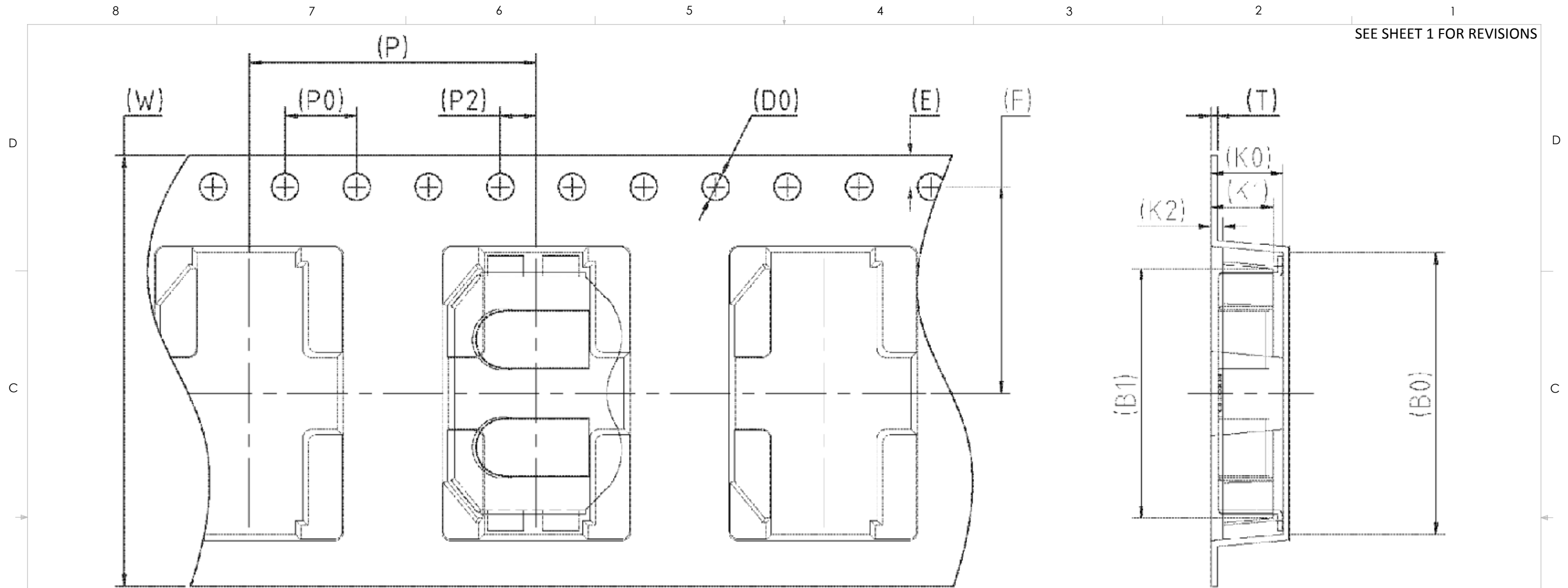

- NOTES: (UNLESS OTHERWISE SPECIFIED)
1. ALL DIMENSIONS ARE IN MILLIMETERS [INCHES].
 2. 10 SPROCKET HOLE PITCH CUMULATIVE TOLERANCE $\pm 0.2\text{mm}$.
 3. MATERIAL: BLACK POLYSTYRENE.
 4. PACKING LENGTH PER 22" REEL: 51.0 m.
 5. COMPONENT LOAD PER 13" REEL: 1000.
 6. ANGLE TOLERANCE: $\pm 1^\circ$
 7. CARRIER CAMBER IS WITHIN 1 mm IN 250 mm.

W	24.00 ± 0.30	P	16.00 ± 0.10	A0	9.80 ± 0.10	B0	15.70 ± 0.10
S		P0	4.00 ± 0.10	A1	5.50 ± 0.10	B1	13.90 ± 0.10
E	1.75 ± 0.10	P2	2.00 ± 0.10	A2		B2	
F	11.50 ± 0.10	D0	$\phi 1.50^{+0.10}_{-0.00}$	K0	4.00 ± 0.10	K2	0.65 ± 0.10
T	0.35 ± 0.05	D1		K1	3.45 ± 0.10	COLOR: BK/ANT	

SIZE	DWG. NO.	REV
B	BAT-HLD-012-SMT-TR	B
SCALE: 4:1	DO NOT SCALE DRAWING	SHEET 2 OF 2