

TOLERANCE			
LINEAR	ANGLES		
X ± 0.40	X° ± 5°		
.X ± 0.30	.X° ± 3°		
.XX ± 0.20	.XX° ± 2°		
.XXX ± 0.10	.XXX° ± 1°		
REV	ECN NO.	NAME	DATE

UMax conn 东莞市友贸实业有限公司
 DONGGUAN UMAX ENTERPRISE LIMITED
 APPD: Jason MAT'L:
 CHKD: Schumi FINISH:
 DRWN: Lei Songping Q' TY:

TITLE: PCI-E CARD EDGE GEN5 SMT
 PART NO. 21650-XXXXXX
 DWG NO. C-21650
 UNITS: MM SCALE: 1:1 SHEET: 1 OF 3 REV: 0

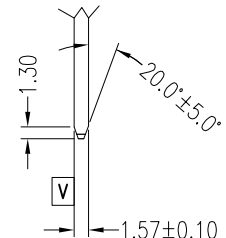
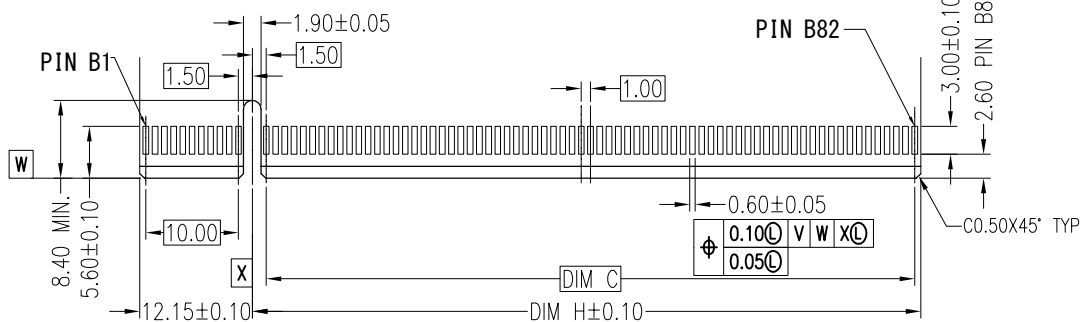

NOTES:
CHAMFER EDGE MUST BE FREE OF CUTTING BURRS

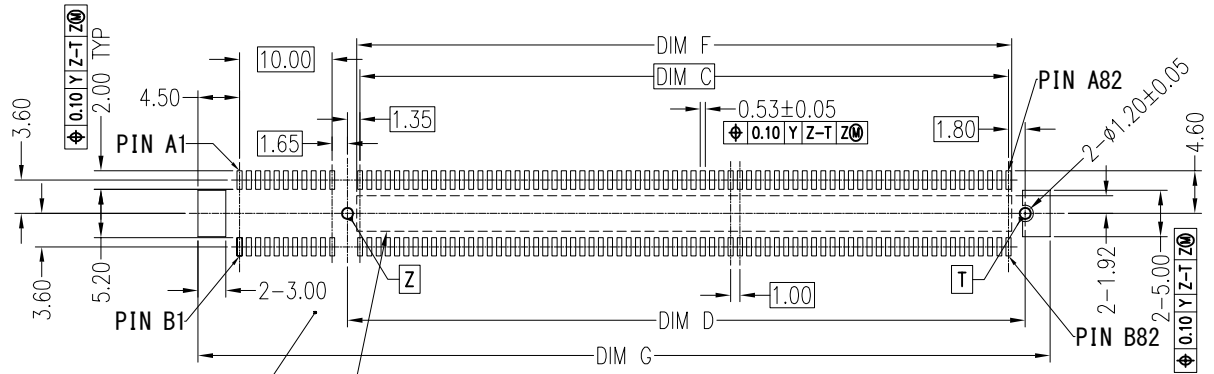
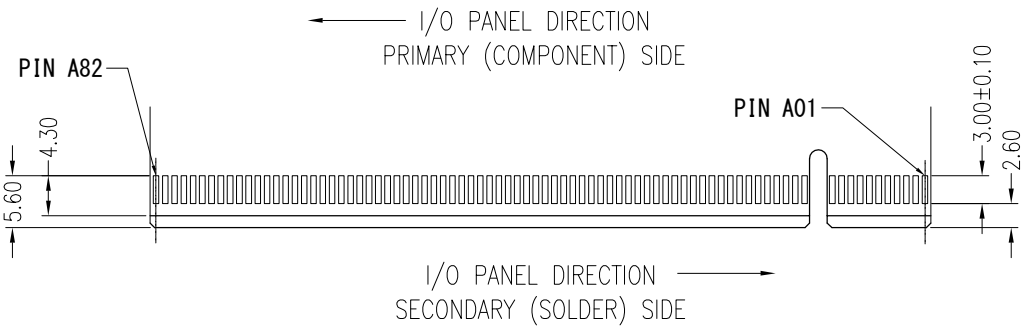

DIMENSIONS								
POSITION	DIM A	DIM B	DIM C	DIM D	DIM E	DIM F	DIM G	DIM H
98	56.00	38.65	37.00	40.15	58	37.70	59	39.15
164	89.00	71.65	70.00	73.15	91	70.70	92	72.15

RECOMMENDED PCB LAYOUT
TOLERANCE ±0.05

TOLERANCE	
LINEAR	ANGLES
X ± 0.40	X° ± 5°
.X ± 0.30	.X° ± 3°
.XX ± 0.20	.XX° ± 2°
.XXX ± 0.10	.XXX° ± 1°

UMax conn 东莞市友贸实业有限公司
DONGGUAN UMAX ENTERPRISE LIMITED

APPD: Jason MAT'L:
CHKD: Schumi FINISH:
DRWN: Lei Songping Q' TY:

TITLE: PCI-E CARD EDGE GEN5 SMT

PART NO. 21650-XXXXXX

DWG NO. C-21650

UNITS	SCALE	SHEET	REV
MM	1 : 1	2 OF 3	0

REV	ECN NO.	NAME	DATE

NOTE:

1.MATERIAL:

HOUSING: THERMOPLASTIC, HIGH TEMP, UL94V-0, BLACK.
 TERMINAL: COPPER ALLOY.
 GND PIN: SUS304 1/2H.
 STATOR: SUS304 1/2H.

2.FINISH:

TERMINAL:
 CONTACT AREA: SELECTIVE GOLD PLATING.
 SOLDERING AREA: TIM PITING 100u"MIN THICKNESS
 UNDER PLATING: NICKEL PLATING 50u"MIN THICKNESS.
 GND PIN: NO PLATING.
 STATOR:
 MATTE TIN PLATING 100u"MIN THICKNESS.OVERALL
 UNDER PLATING: NICKEL PLATING 50u"MIN THICKNESS.

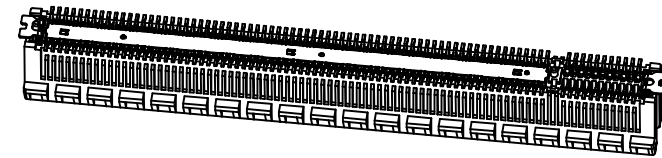

PART NO.

21650 - X 1 X X X X

Ridge Options
 0: Non Ridge
 1: With Ridge

HSG Color
 1: Black

Post Options
 0: With Post
 1: Without Post

Contact Plating
 0: 30u" Gold
 1: 15u" Gold
 2: Gold Flash

Packing Options
 T-Tray Packaging
 C-Tray Packaging With Cap

No. of Pins
 2: 98P
 3: 164P

TOLERANCE	
LINEAR	ANGLES
X. ±0.40	X° ± 5°
.X ±0.30	.X° ± 3°
.XX ±0.20	.XX° ± 2°
.XXX ±0.10	.XXX° ± 1°

UMax conn 东莞市友贸实业有限公司
 DONGGUAN UMAX ENTERPRISE LIMITED

TITLE: PCI-E CARD EDGE GEN5 SMT

PART NO. 21650-XXXXXX

DWG NO. C-21650

APPD: Jason MAT'L:
 CHKD: Schumi FINISH:
 DRWN: Lei Songping Q'TY:

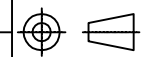

UNITS	SCALE	SHEET	REV
MM	1 : 1	3 OF 3	0

REV	ECN NO.	NAME	DATE