

THIS DRAWING IS UNPUBLISHED. RELEASED FOR PUBLICATION 20
 © COPYRIGHT 20 BY - ALL RIGHTS RESERVED.

| REVISIONS | | | | |
|-----------|-----|----------------------|-----------|-------|
| P | LTR | DESCRIPTION | DATE | APVD |
| | A | INITIAL RELEASE | 21SEP2019 | AJ SH |
| | A1 | ADDED NEW DASH -5 | 18NOV2019 | AJ SH |
| | A2 | ADDED NEW DASH -6/-7 | 16MAR2020 | AJ SH |

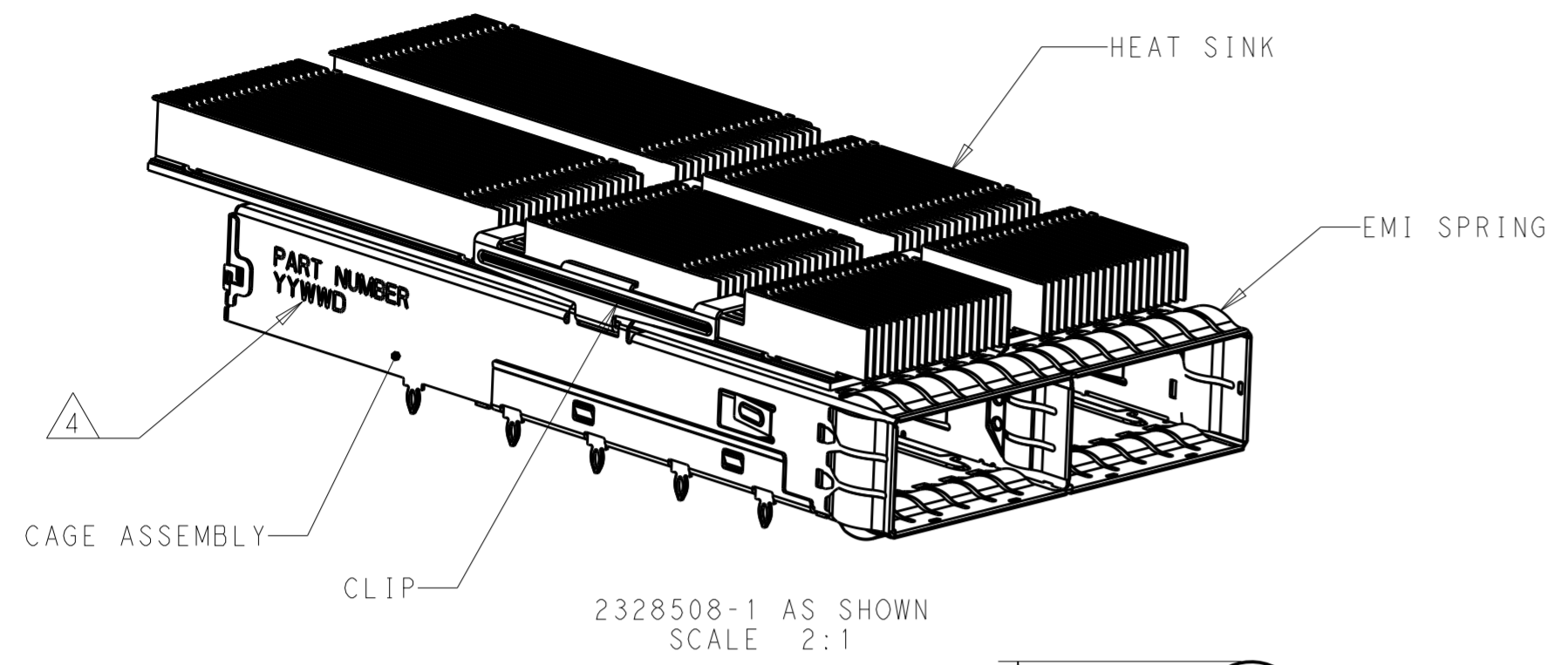

NOTES:

- ① CAGE ASSEMBLY: STAINLESS STEEL.
HEAT SINK: ALUMINUM/BLACK ANODIZE.
HEAT SINK CLIP: STAINLESS STEEL.
EMI SPRING: COPPER ALLOY/NICKEL PLATE.
SEAL SHEET: STAINLESS STEEL.
- ② REFERENCE APPLICATION SPECIFICATION 114-60025 FOR RECOMMENDED DRILL HOLE DIAMETER AND PLATING THICKNESS. BOARD LAYOUT PER THIS PRINT.
- ③ DATUM AND BASIC DIMENSION ESTABLISHED BY CUSTOMER.
- ④ PART NUMBER AND DATE CODE (YYWWD) MARKED APPROXIMATELY AS SHOWN.
- 5. MATES WITH QSFP DD MSA COMPATIBLE TRANSCEIVER.
- 6. MINIMUM PC BOARD THICKNESS: SINGLE SIDED: 1.57 MIN
DOUBLE SIDED: 3.00 MIN
- ⑦ DIMENSION APPLIES WITH MODULE INSERTED.

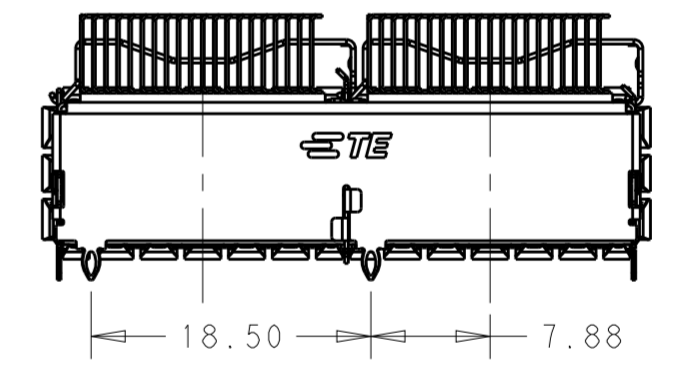
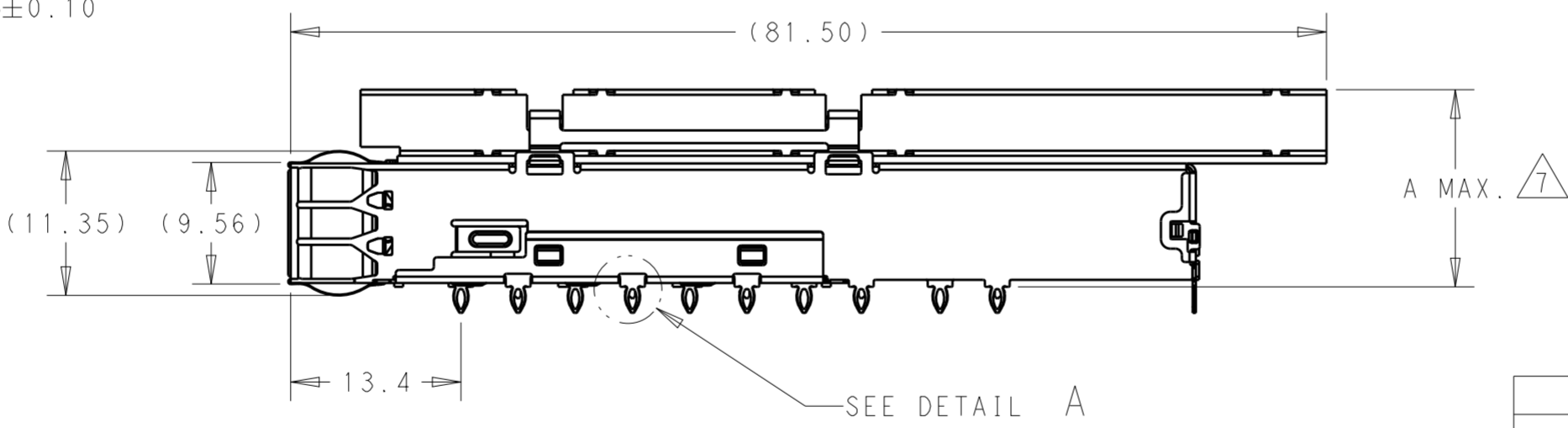
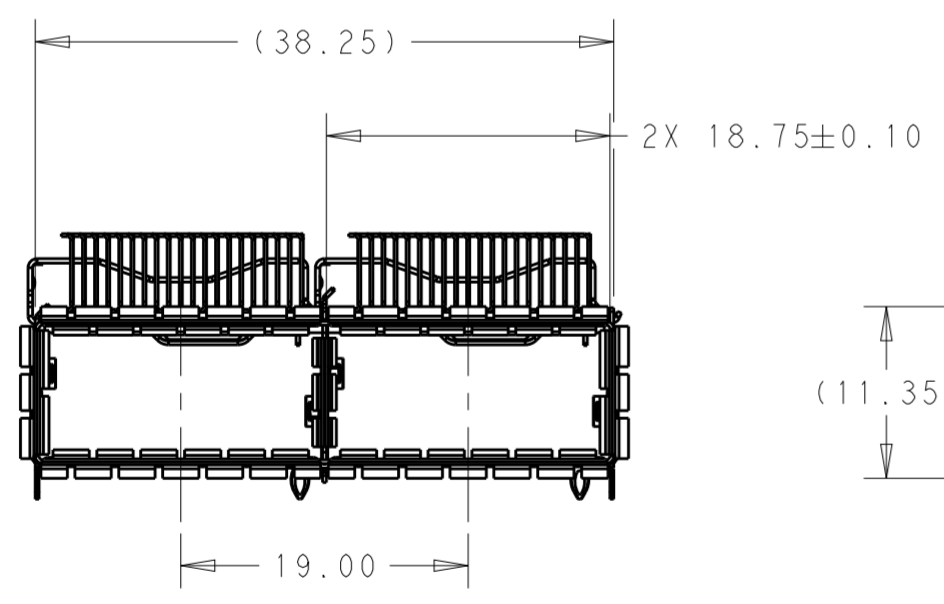
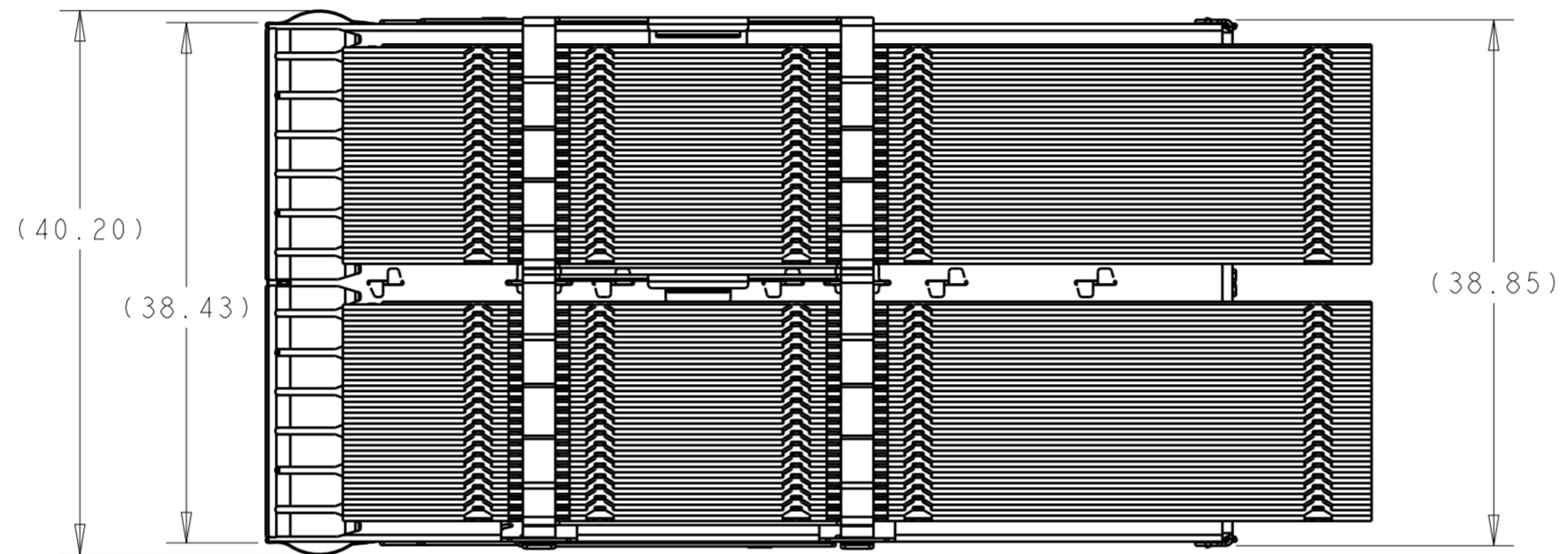

2328508-1 AS SHOWN

| | | | | |
|------------|----------------|------------|-------|-------------|
| NO | CUSTOMIZED FIN | 2 | 30.0 | 2328508-7 |
| NO | CUSTOMIZED FIN | 2 | 19.5 | 2328508-6 |
| YES | HIGHER FIN | 2 | 31.7 | 2328508-5 |
| YES | LONGER FIN | 2 | 19.5 | 2328508-4 |
| NO | WIDER FIN | 0 | 16.0 | 2328508-3 |
| NO | STANDARD | 0 | 16.0 | 2328508-2 |
| NO | STANDARD | 2 | 16.0 | 2328508-1 |
| SEAL SHEET | HEAT SINK | REAR PIN # | DIM.A | PART NUMBER |

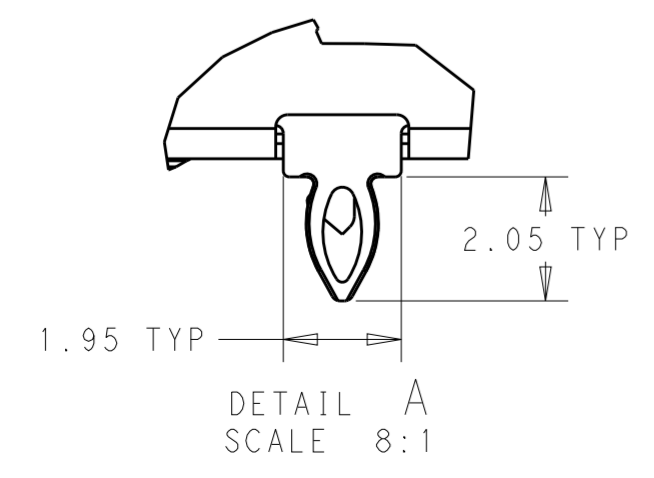

| | | | | |
|--|--|--------------------------------|------------------------------------|--------------------|
| THIS DRAWING IS A CONTROLLED DOCUMENT. | | DWN ARTHUR JIN 21NOV2017 | TE Connectivity | |
| DIMENSIONS: mm | | CHK SEAN HAN 21NOV2017 | | |
| TOLERANCES UNLESS OTHERWISE SPECIFIED: | | APVD SEAN HAN 21NOV2017 | NAME QSFP-DD, 1X2 CAGE ASSEMBLY | |
| 0 PLC ±0.25 | | PRODUCT SPEC 108-60122 | WITH EMI SPRING, HEAT SINK | |
| 1 PLC ±0.25 | | APPLICATION SPEC 114-60025 | SIZE A2 | CAGE CODE - |
| 2 PLC ±0.20 | | WEIGHT - | DRAWING NO C-2328508 | RESTRICTED TO - |
| 3 PLC ±0.10 | | CUSTOMER DRAWING | SCALE 1:1 | SHEET 1 OF 7 |
| 4 PLC ± | | | REV A2 | |
| ANGLES ± | | | | |
| FINISH SEE NOTE | | | | |

THIS DRAWING IS UNPUBLISHED. RELEASED FOR PUBLICATION 20
 © COPYRIGHT 20 BY - ALL RIGHTS RESERVED.

| REVISIONS | | | | |
|-----------|-----|-------------|------|------|
| P | LTR | DESCRIPTION | DATE | APVD |
| - | | SEE SHEET 1 | - | - |
| | | | | |
| | | | | |

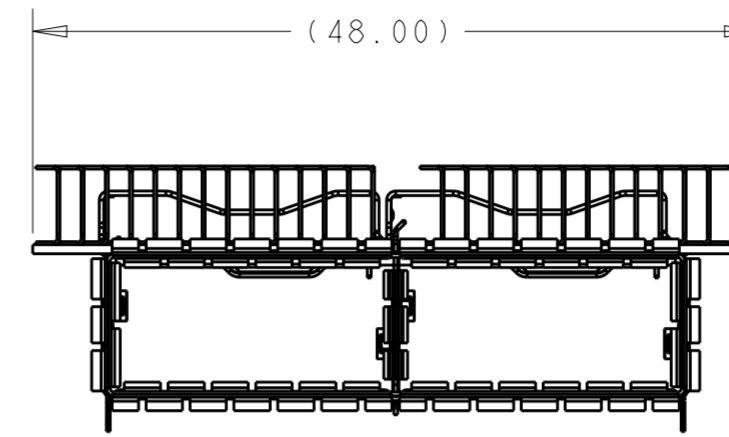
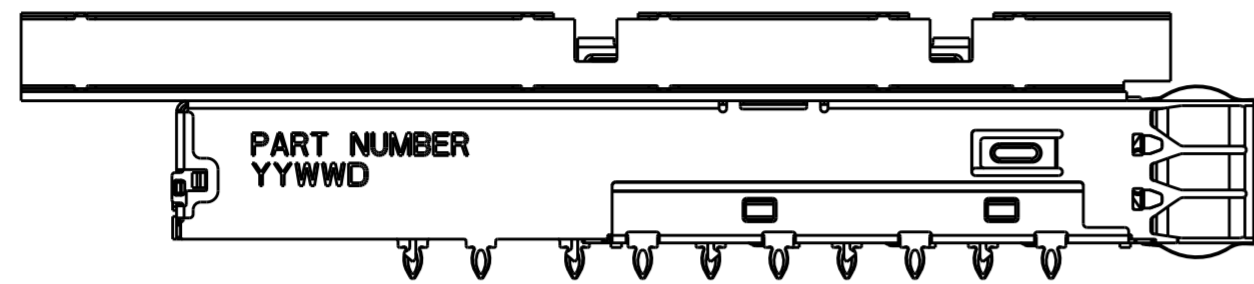

2328508-3
 UNSPECIFIED PROFILE SAME AS 2328508-2
 SCALE 2:1

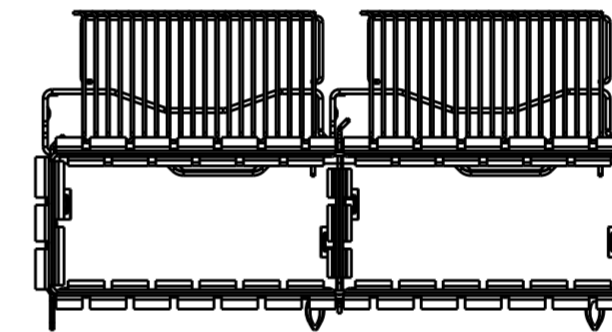
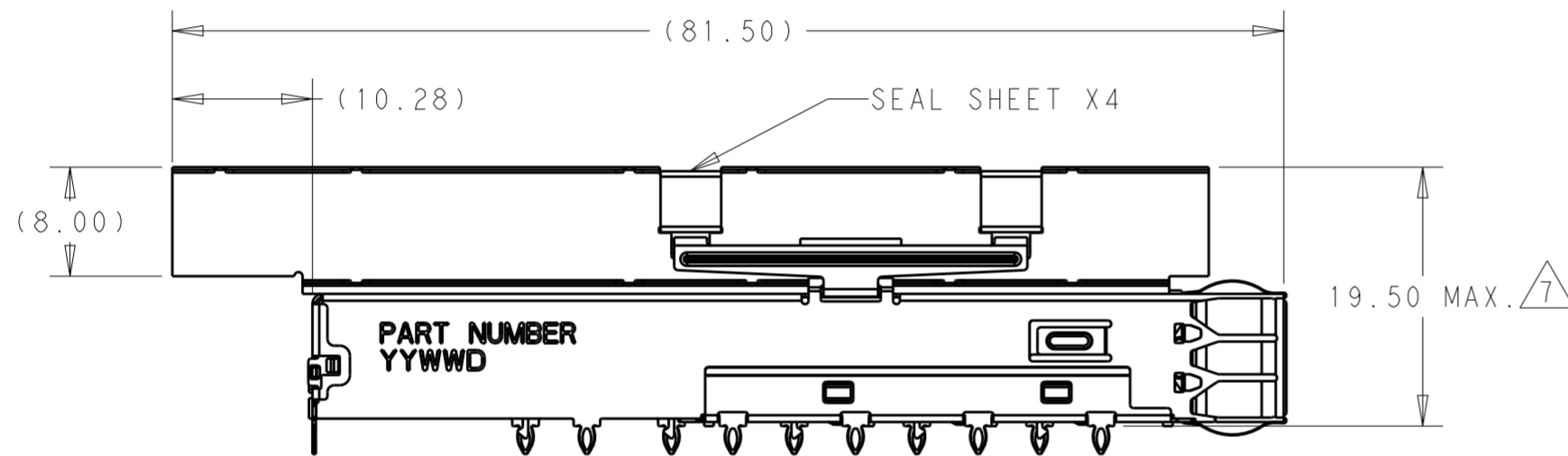

2328508-4
 UNSPECIFIED DIMENSIONS SAME AS -1
 SCALE 2:1

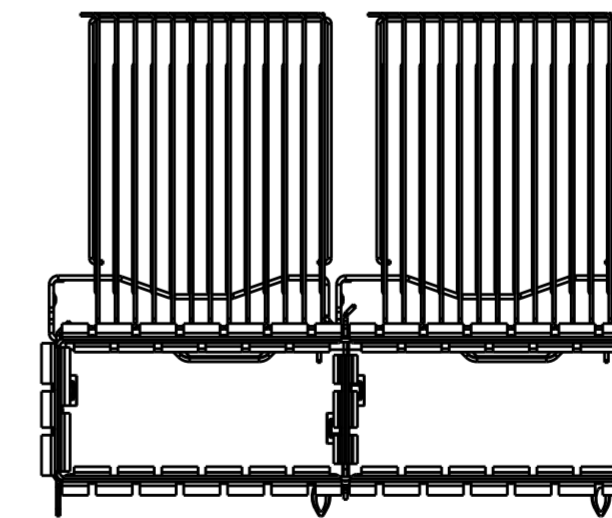
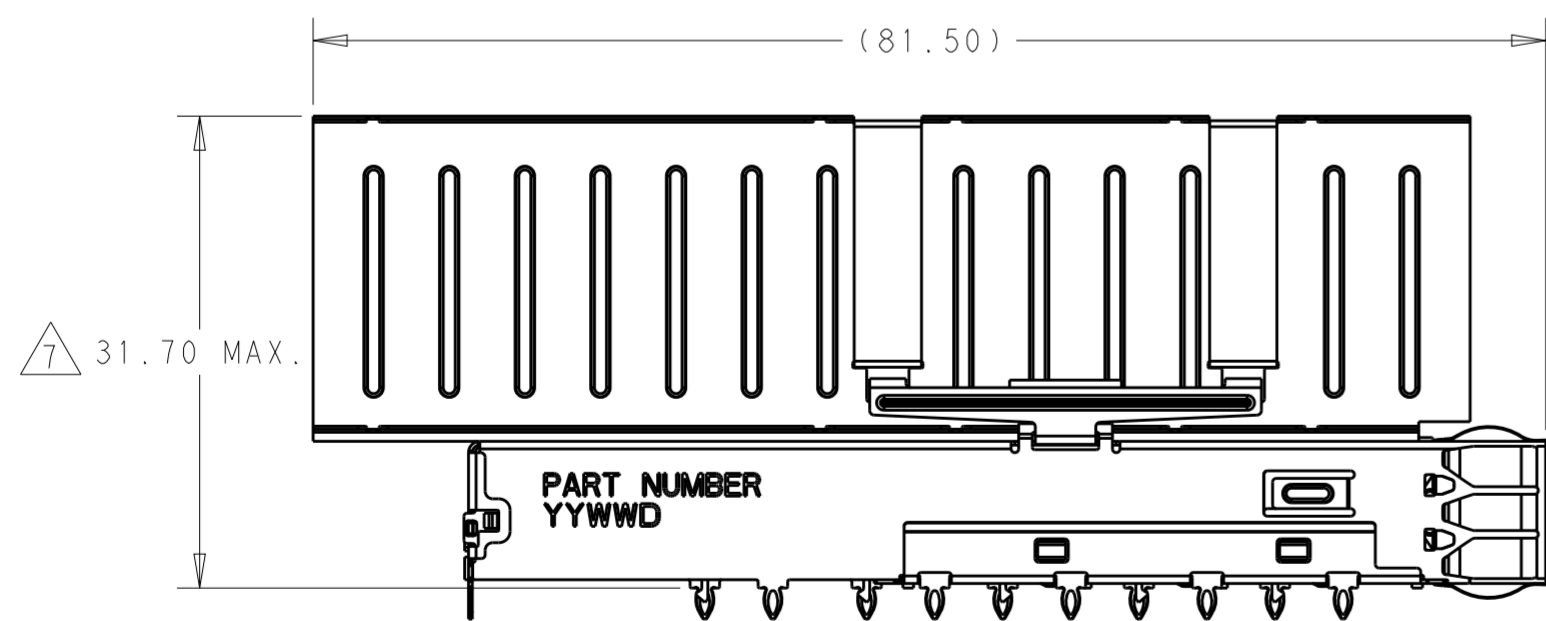

2328508-5 AS SHOWN
 W/ HIGH HEAT SINK
 SCALE 2:1

| | | | | |
|---|--|--------------------------------|------------------------------------|-------------------------|
| THIS DRAWING IS A CONTROLLED DOCUMENT. | | DWN ARTHUR JIN 21NOV2017 | TE Connectivity | |
| DIMENSIONS: mm | | CHK SEAN HAN 21NOV2017 | | |
| TOLERANCES UNLESS OTHERWISE SPECIFIED: | | APVD SEAN HAN 21NOV2017 | NAME QSFP-DD, 1X2 CAGE ASSEMBLY | |
| 0 PLC ±0.25 1 PLC ±0.25 2 PLC ±0.20 3 PLC ±0.10 4 PLC ± ANGLES ± FINISH | | PRODUCT SPEC 108-60122 | WITH EMI SPRING, HEAT SINK | |
| MATERIAL SEE NOTE | | APPLICATION SPEC 114-60025 | SIZE A2 | RESTRICTED TO |
| | | WEIGHT - | CAGE CODE - | DRAWING NO C-2328508 |
| | | CUSTOMER DRAWING | SCALE 1:1 | SHEET 2 OF 7 |
| | | | | REV A2 |

THIS DRAWING IS UNPUBLISHED. RELEASED FOR PUBLICATION 20
 © COPYRIGHT 20 BY - ALL RIGHTS RESERVED.

| REVISIONS | | | | |
|-----------|-----|-------------|------|------|
| P | LTR | DESCRIPTION | DATE | APVD |
| - | | SEE SHEET 1 | - | - |
| | | | | |
| | | | | |

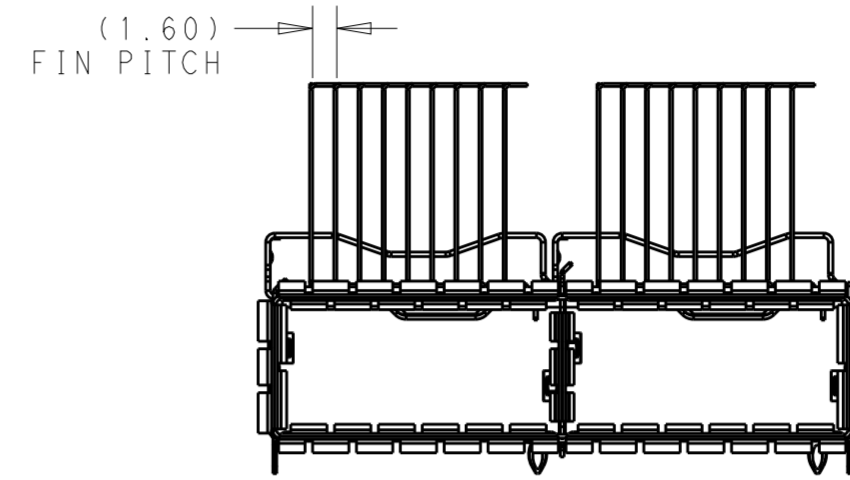
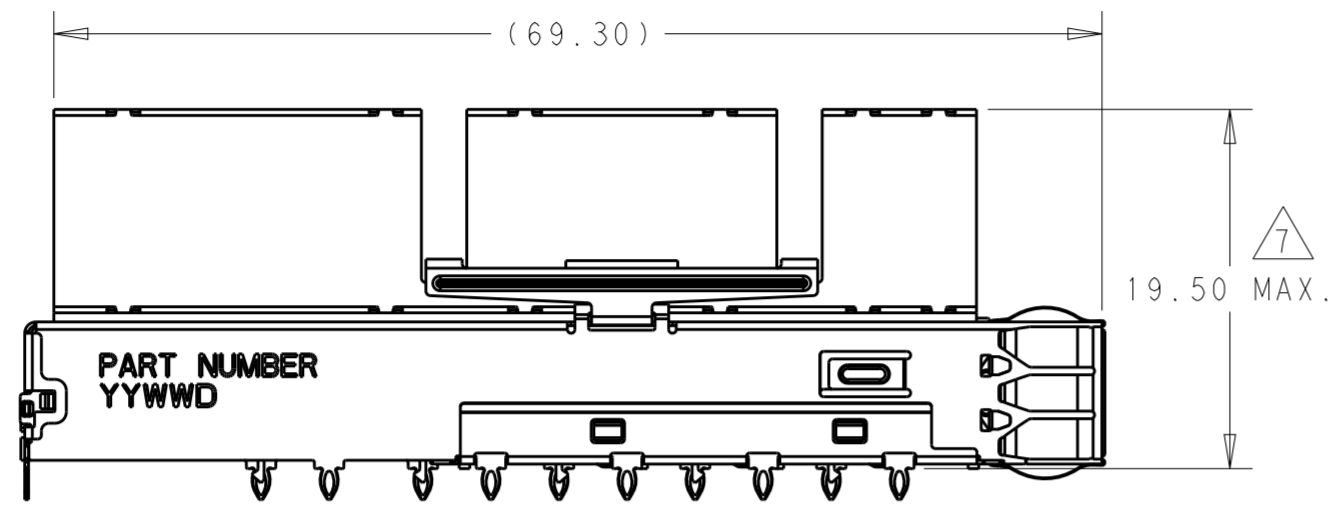

2328508-6 AS SHOWN
 UNSPECIFIED DIMENSIONS SAME AS -1
 SCALE 2:1

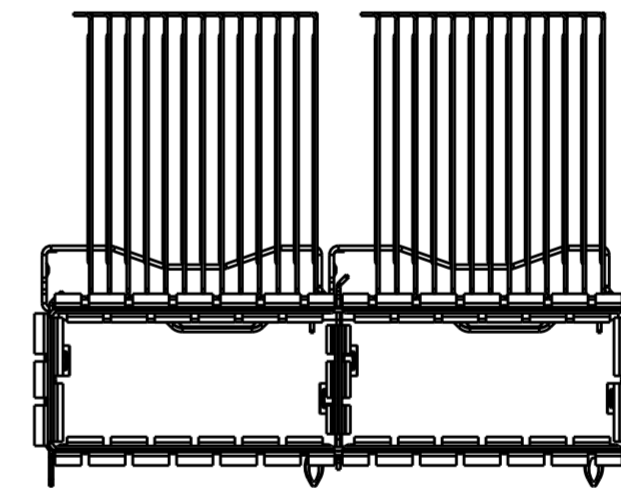
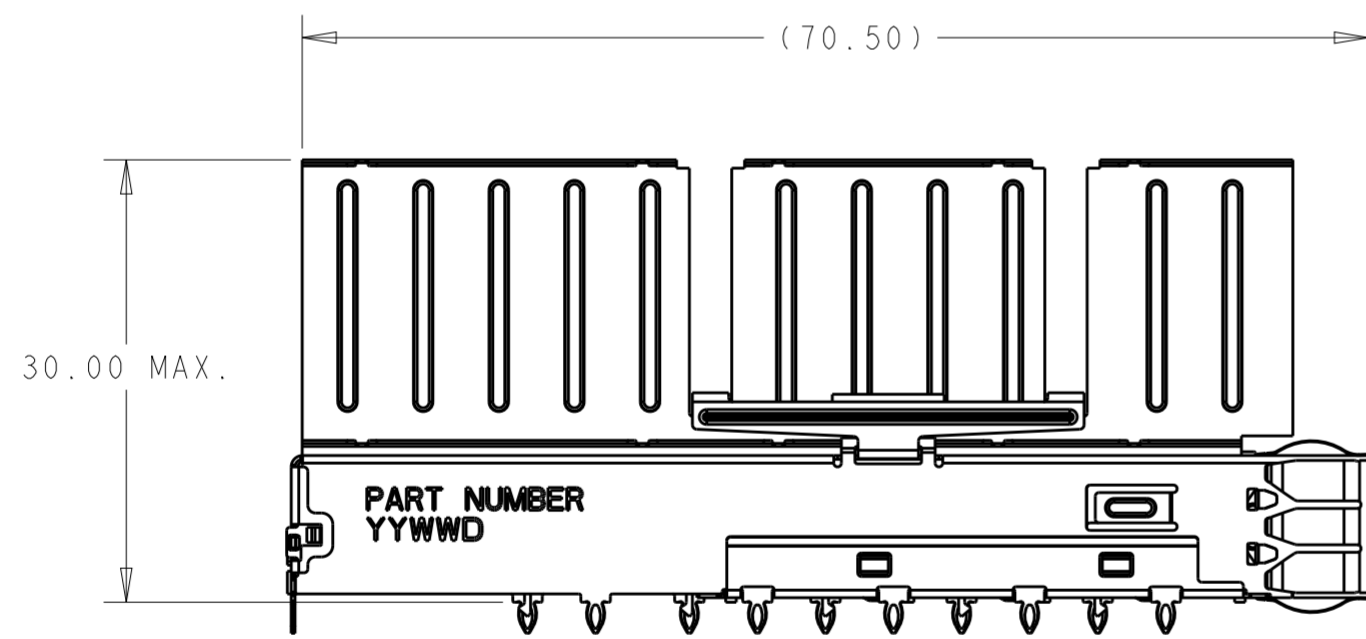

2328508-7 AS SHOWN
 UNSPECIFIED DIMENSIONS SAME AS -1
 SCALE 2:1

| | | | | |
|---|--|--------------------------------|------------------------------------|--------------------|
| THIS DRAWING IS A CONTROLLED DOCUMENT. | | DWN ARTHUR JIN 21NOV2017 | TE Connectivity | |
| | | CHK SEAN HAN 21NOV2017 | | |
| | | APVD SEAN HAN 21NOV2017 | NAME QSFP-DD, 1X2 CAGE ASSEMBLY | |
| DIMENSIONS: mm | | PRODUCT SPEC 108-60122 | WITH EMI SPRING, HEAT SINK | |
| TOLERANCES UNLESS OTHERWISE SPECIFIED: | | APPLICATION SPEC 114-60025 | SIZE A2 | CAGE CODE - |
| 0 PLC ±0.25 1 PLC ±0.25 2 PLC ±0.20 3 PLC ±0.10 4 PLC ± ANGLES ± FINISH | | WEIGHT - | DRAWING NO C-2328508 | RESTRICTED TO - |
| MATERIAL SEE NOTE | | CUSTOMER DRAWING | SCALE 1:1 | SHEET 3 OF 7 |
| | | | | REV A2 |

THIS DRAWING IS UNPUBLISHED. RELEASED FOR PUBLICATION 20
 © COPYRIGHT 20 BY - ALL RIGHTS RESERVED.

| REVISIONS | | | | | |
|-----------|-----|-------------|------|-----|------|
| P | LTR | DESCRIPTION | DATE | DWN | APVD |
| - | | SEE SHEET 1 | - | - | - |
| | | | | | |
| | | | | | |

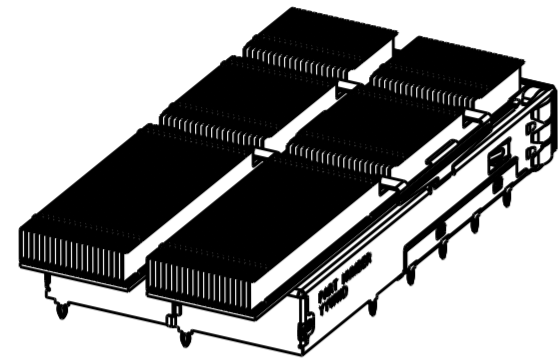

2328508-1 AS SHOWN
2 REAR PINS
SCALE 1:1

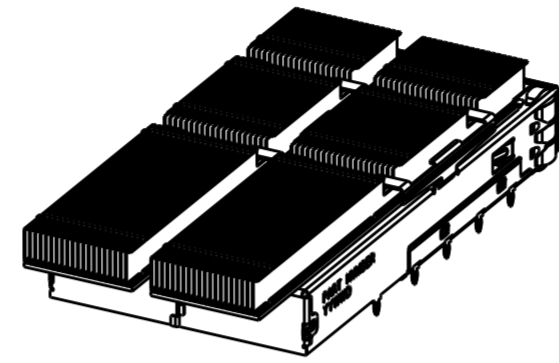

2328508-2 AS SHOWN
0 REAR PINS
SCALE 1:1

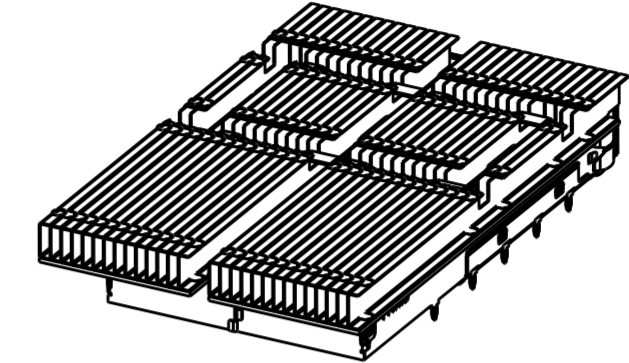

2328508-3 AS SHOWN
0 REAR PINS
SCALE 1:1

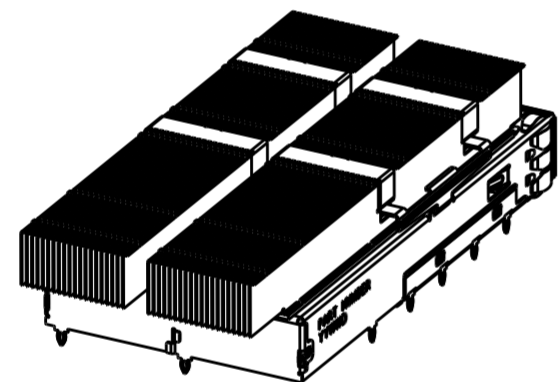

2328508-4 AS SHOWN
SCALE 1:1

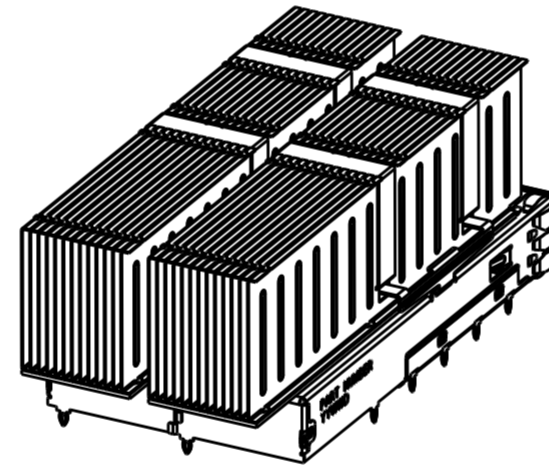

2328508-5 AS SHOWN
SCALE 1:1

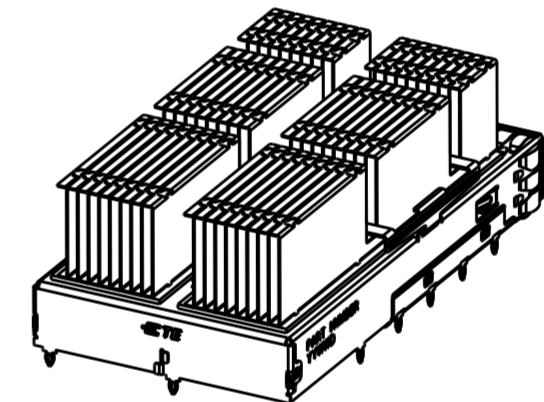

2328508-6 AS SHOWN
SCALE 1:1

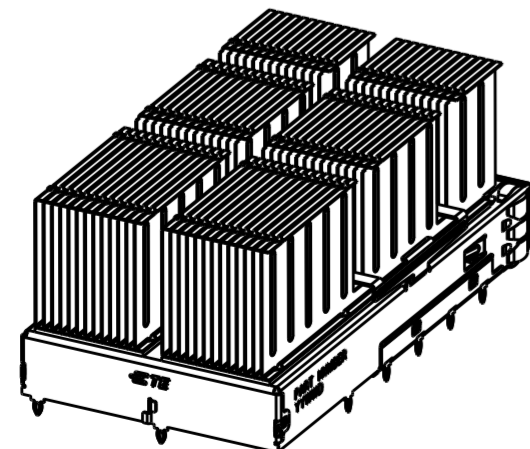

2328508-7 AS SHOWN
SCALE 1:1

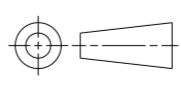
| | | | | |
|---|--|--------------------------------|---|-------------------------|
| THIS DRAWING IS A CONTROLLED DOCUMENT. | | DWN ARTHUR JIN 21NOV2017 |  TE Connectivity | |
| DIMENSIONS: mm | | CHK SEAN HAN 21NOV2017 | | |
| TOLERANCES UNLESS OTHERWISE SPECIFIED: | | APVD SEAN HAN 21NOV2017 | NAME QSFP-DD, 1X2 CAGE ASSEMBLY | |
|  | | PRODUCT SPEC 108-60122 | WITH EMI SPRING, HEAT SINK | |
| MATERIAL SEE NOTE | | APPLICATION SPEC 114-60025 | SIZE A2 | RESTRICTED TO - |
| FINISH SEE NOTE | | WEIGHT - | CAGE CODE - | DRAWING NO G-2328508 |
| | | CUSTOMER DRAWING | SCALE 1:1 | SHEET 4 OF 7 |
| | | | | REV A2 |

THIS DRAWING IS UNPUBLISHED. RELEASED FOR PUBLICATION 20
 © COPYRIGHT 20 BY - ALL RIGHTS RESERVED.

| REVISIONS | | | | |
|-----------|-----|-------------|------|------|
| P | LTR | DESCRIPTION | DATE | APVD |
| - | - | SEE SHEET 1 | - | - |
| | | | | |
| | | | | |

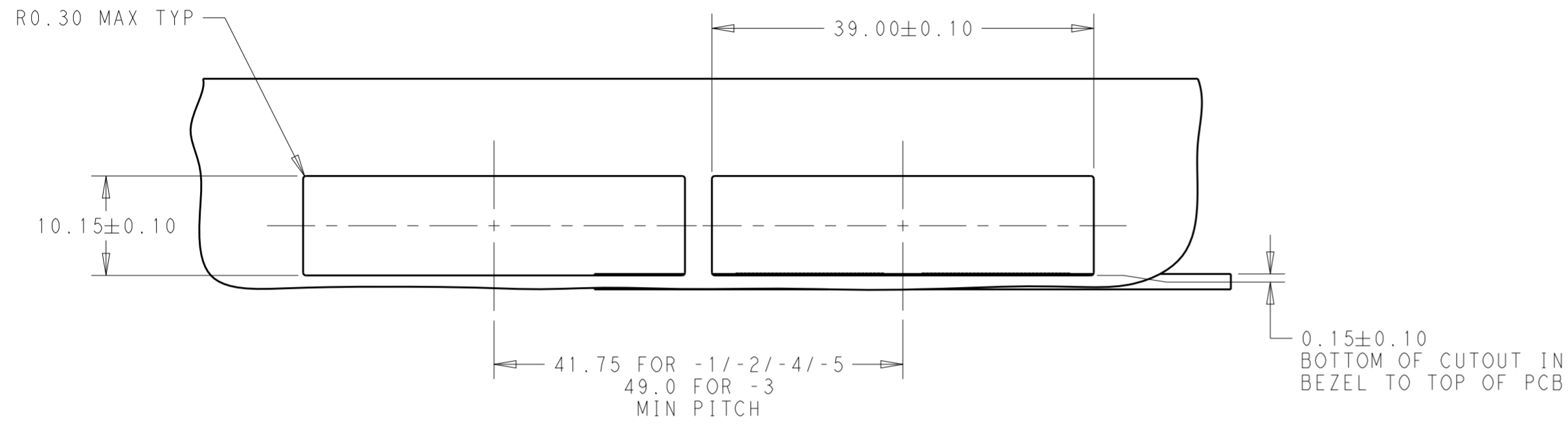

CAGE ASSEMBLY OMITTED FOR CLARITY

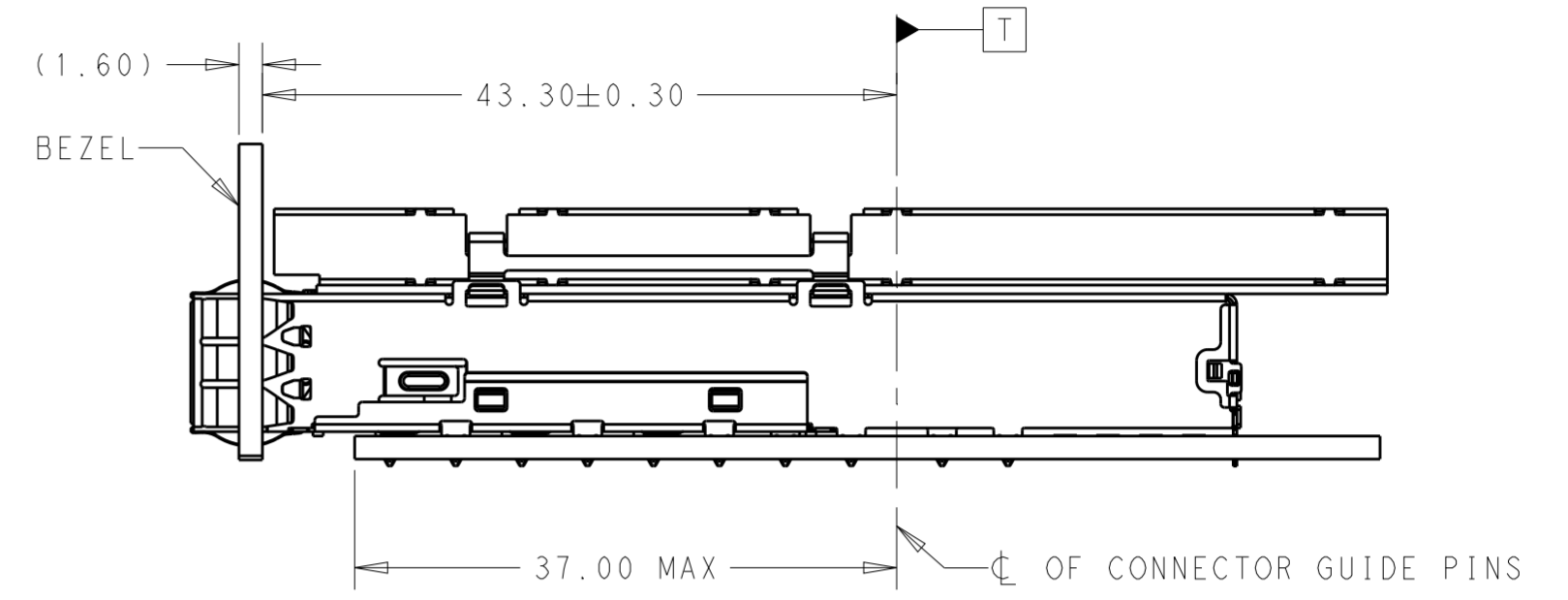

SINGLE SIDE MOUNTING

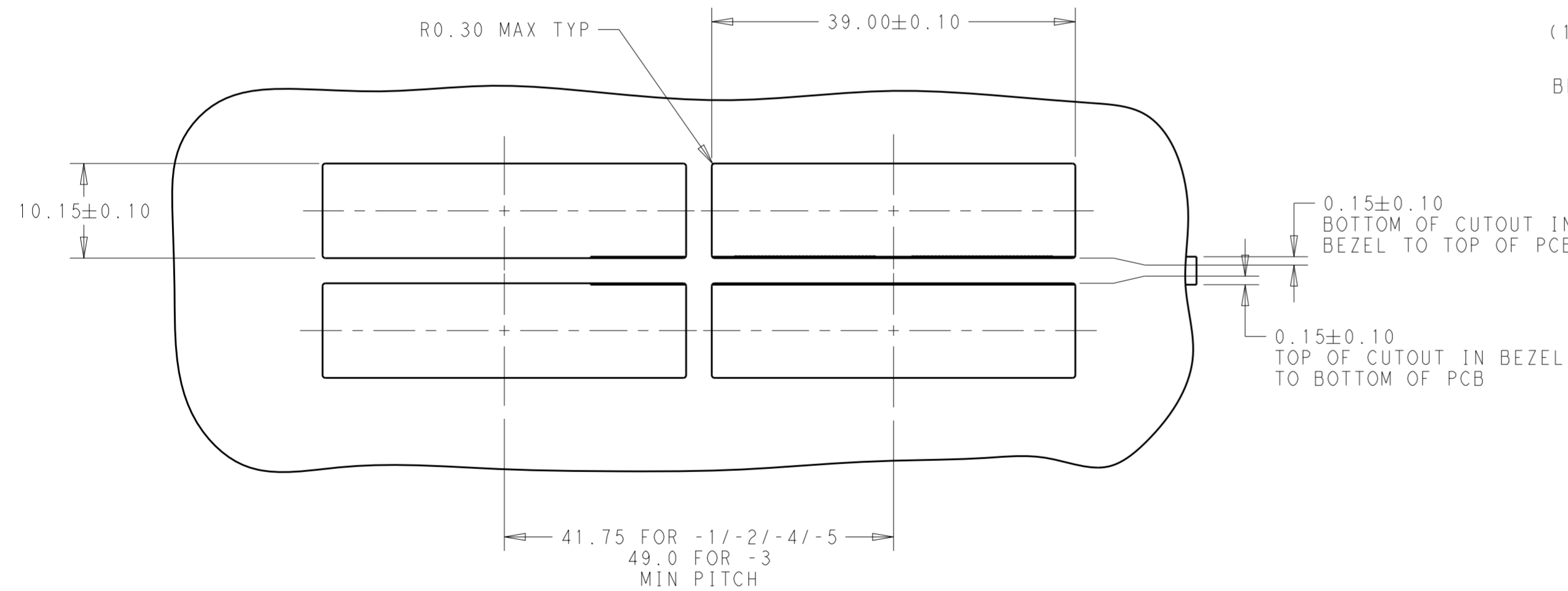

CAGE ASSEMBLY OMITTED FOR CLARITY

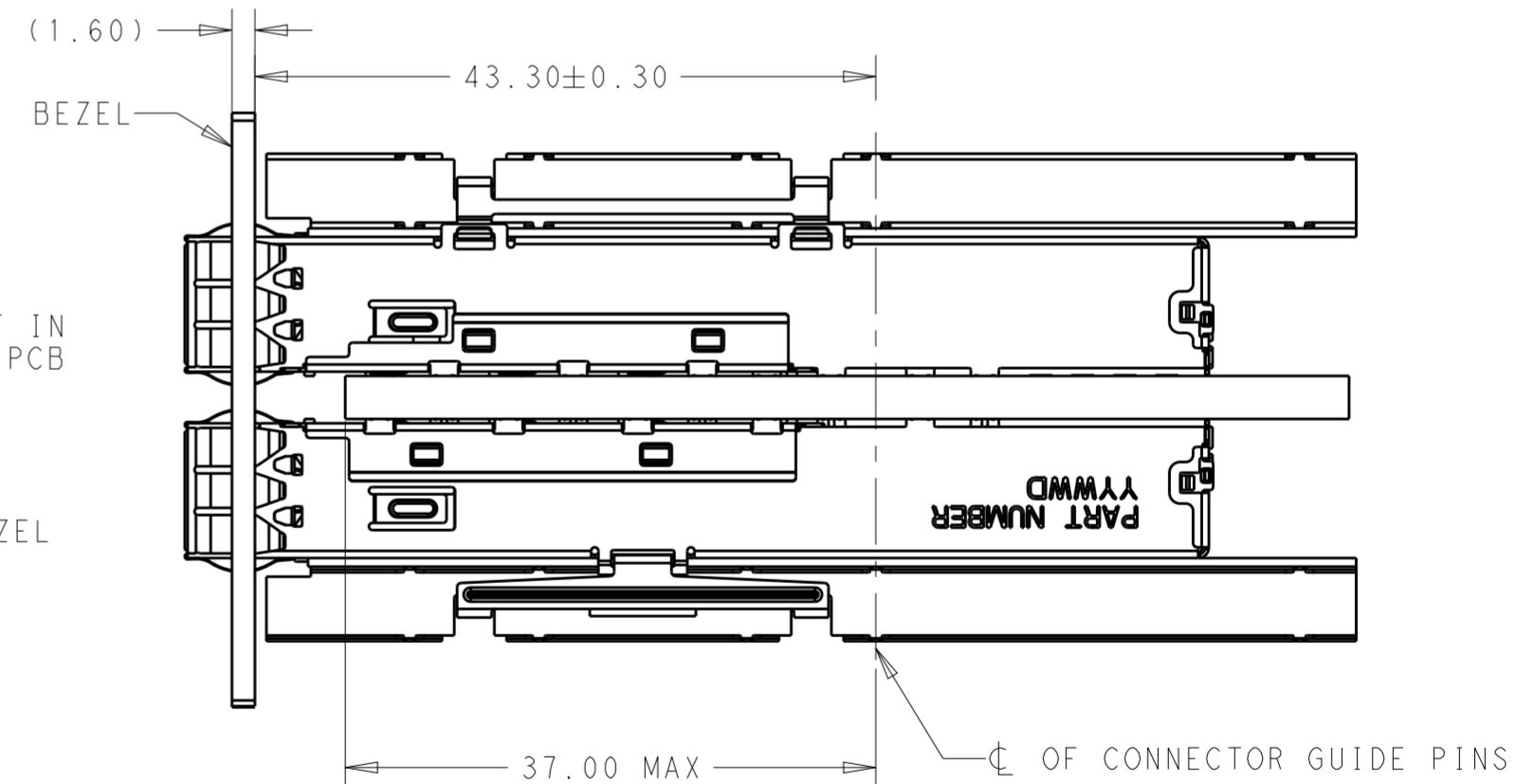

BELLY TO BELLY MOUNTING

| | | | | |
|--|--|--------------------------------|------------------------------------|--------------------|
| THIS DRAWING IS A CONTROLLED DOCUMENT. | | DWN ARTHUR JIN 21NOV2017 | TE Connectivity | |
| DIMENSIONS: mm | | CHK SEAN HAN 21NOV2017 | | |
| TOLERANCES UNLESS OTHERWISE SPECIFIED: | | APVD SEAN HAN 21NOV2017 | NAME QSFP-DD, 1X2 CAGE ASSEMBLY | |
| 0 PLC ±0.25 | | PRODUCT SPEC | WITH EMI SPRING, HEAT SINK | |
| 1 PLC ±0.25 | | 108-60122 | SIZE A2 | CAGE CODE - |
| 2 PLC ±0.20 | | APPLICATION SPEC | DRAWING NO C-2328508 | RESTRICTED TO - |
| 3 PLC ±0.10 | | 114-60025 | SCALE 1:1 | SHEET 5 OF 7 |
| 4 PLC ± | | WEIGHT - | REV A2 | |
| ANGLES ± | | CUSTOMER DRAWING | | |
| FINISH | | | | |
| MATERIAL SEE NOTE | | | | |
| SEE NOTE | | | | |

THIS DRAWING IS UNPUBLISHED. RELEASED FOR PUBLICATION 20
 © COPYRIGHT 20 BY - ALL RIGHTS RESERVED.

| REVISIONS | | | | |
|-----------|-----|-------------|------|------|
| P | LTR | DESCRIPTION | DATE | APVD |
| - | - | SEE SHEET 1 | - | - |

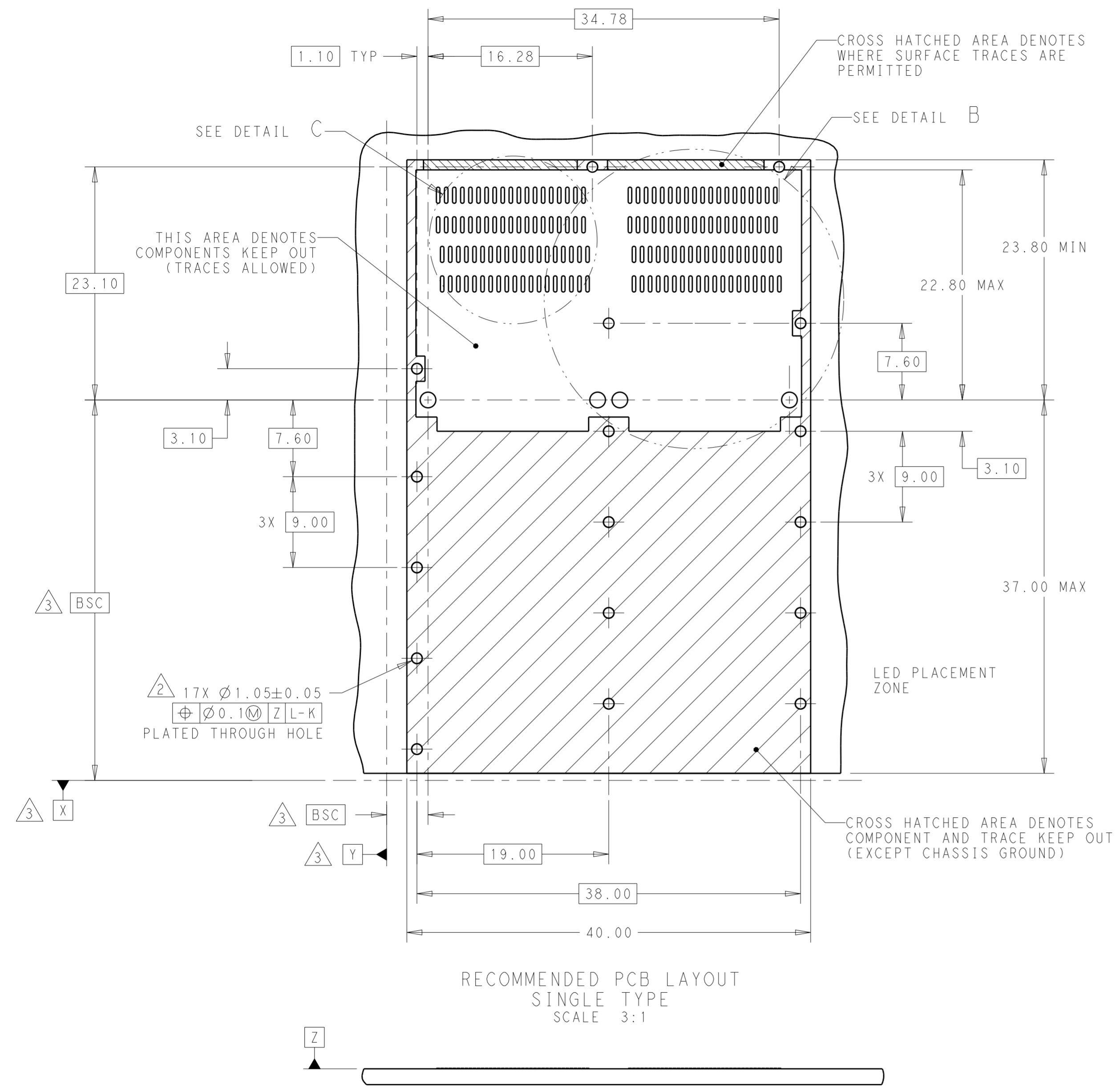

RECOMMENDED PCB LAYOUT
 SINGLE TYPE
 SCALE 3:1

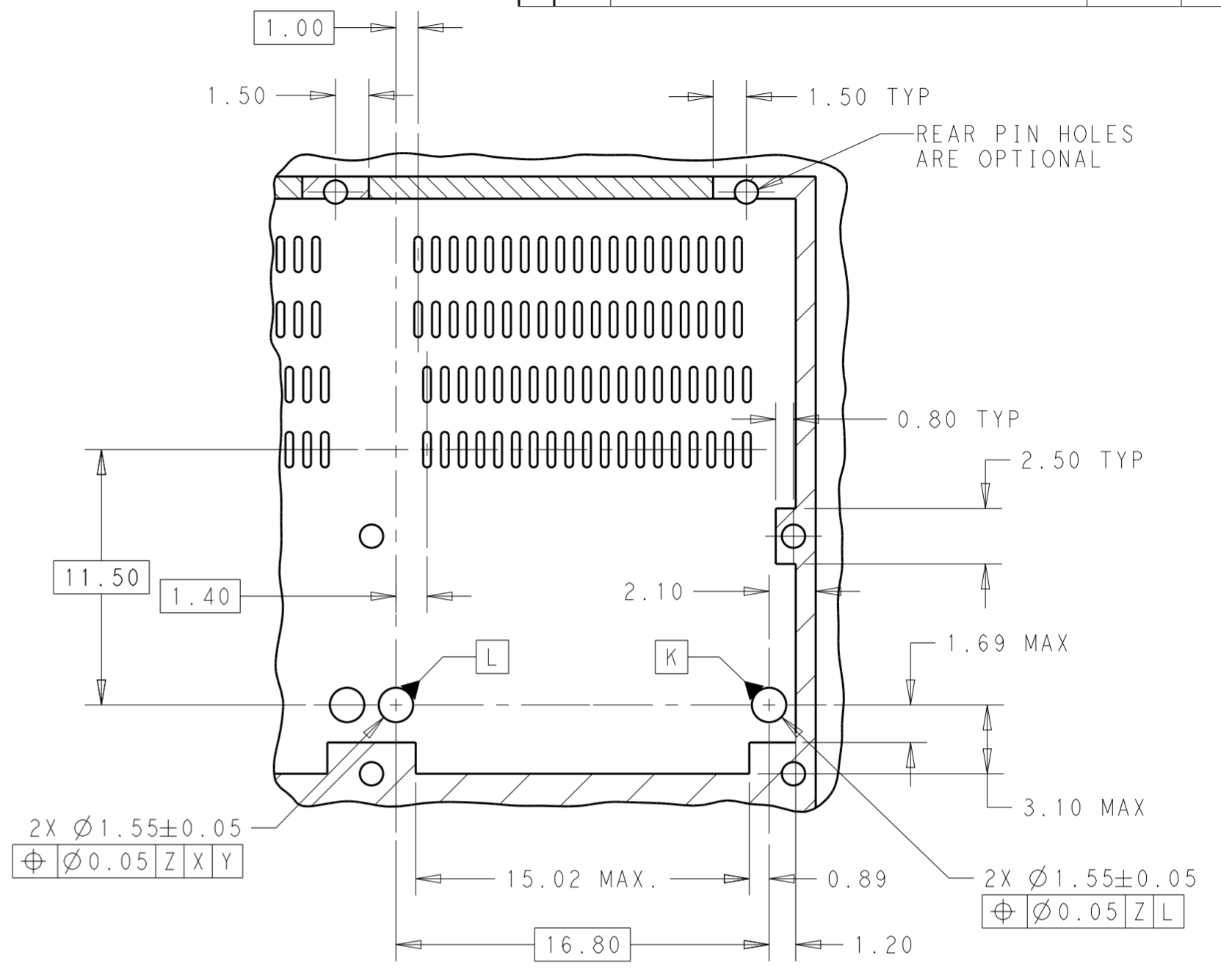

DETAIL B
 SCALE 4:1

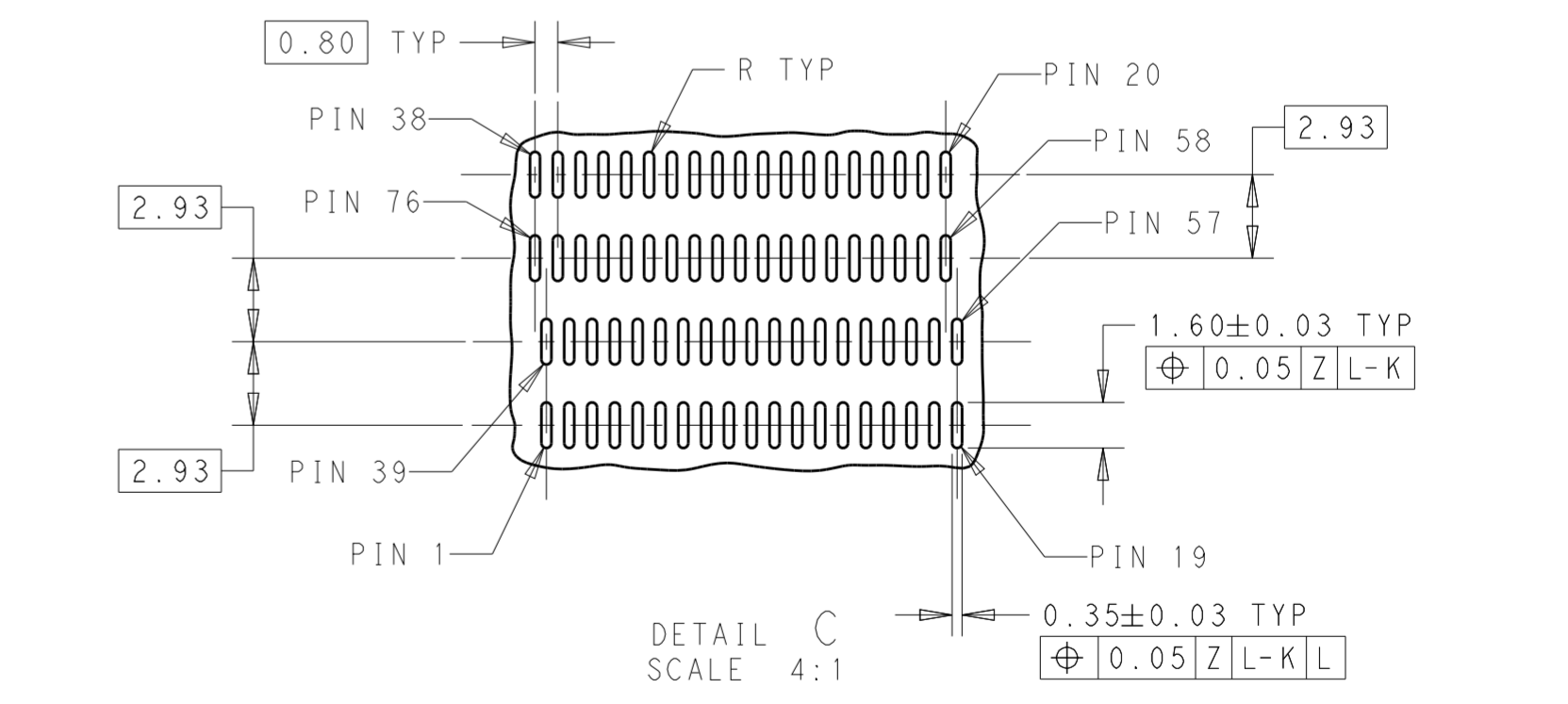

DETAIL C
 SCALE 4:1

| | | | | |
|--|--|-------------------------------|------------------------------------|--------------------|
| THIS DRAWING IS A CONTROLLED DOCUMENT. | | DWN 21NOV2017 ARTHUR JIN | TE Connectivity | |
| | | CHK 21NOV2017 SEAN HAN | | |
| DIMENSIONS: mm | | APVD 21NOV2017 SEAN HAN | NAME QSFP-DD, 1X2 CAGE ASSEMBLY | |
| TOLERANCES UNLESS OTHERWISE SPECIFIED: | | PRODUCT SPEC 108-60122 | WITH EMI SPRING, HEAT SINK | |
| 0 PLC ±0.25 | | APPLICATION SPEC 114-60025 | SIZE A2 | CAGE CODE - |
| 1 PLC ±0.25 | | WEIGHT - | DRAWING NO C-2328508 | RESTRICTED TO - |
| 2 PLC ±0.20 | | CUSTOMER DRAWING | SCALE 1:1 | SHEET 6 OF 7 |
| 3 PLC ±0.10 | | | | REV A2 |
| 4 PLC ± | | | | |
| ANGLES ± | | | | |
| FINISH SEE NOTE | | | | |

THIS DRAWING IS UNPUBLISHED. RELEASED FOR PUBLICATION 20
 © COPYRIGHT 20 BY - ALL RIGHTS RESERVED.

| REVISIONS | | | | |
|-----------|-----|-------------|------|------|
| P | LTR | DESCRIPTION | DATE | APVD |
| - | - | SEE SHEET 1 | - | - |
| | | | | |
| | | | | |

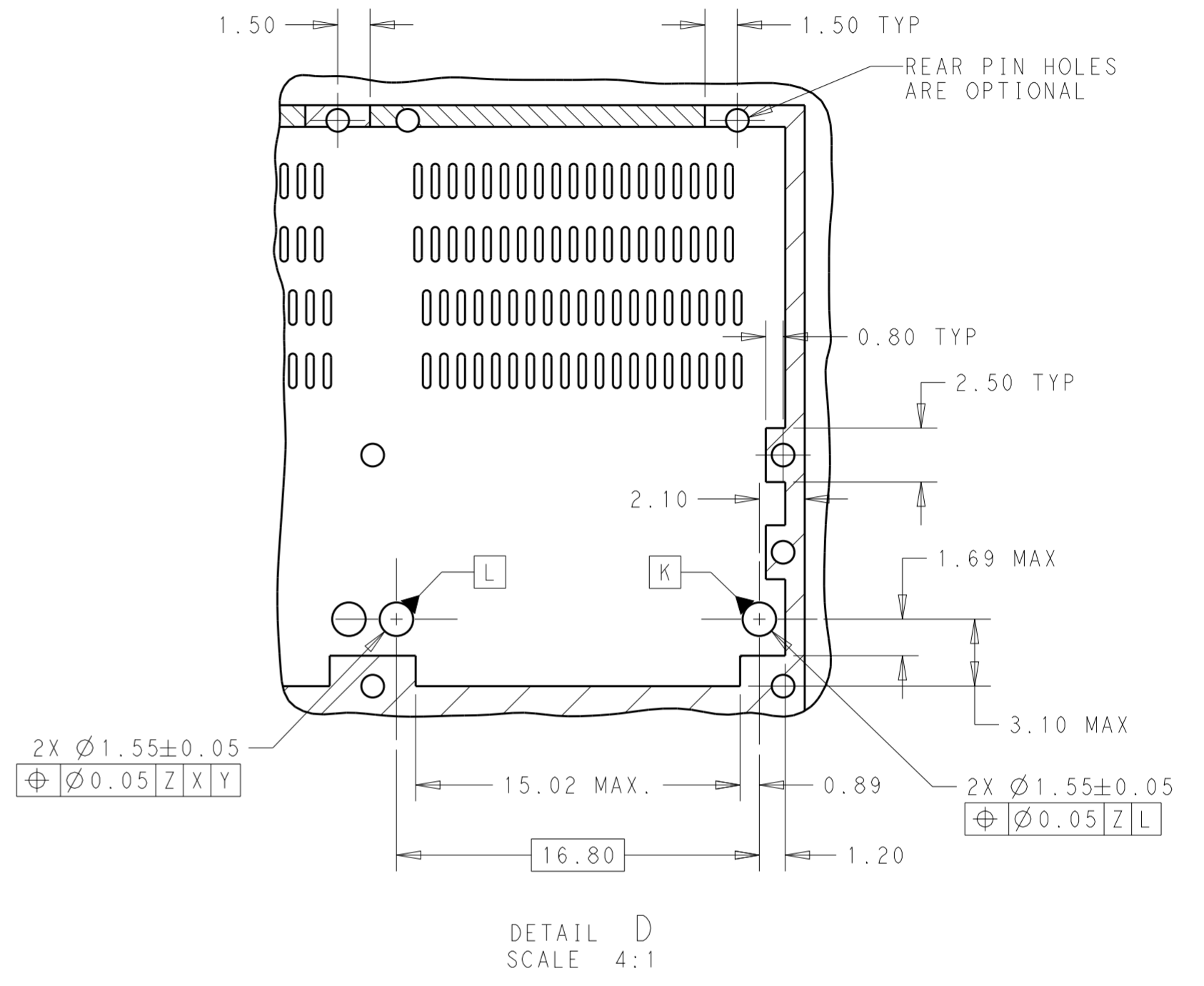
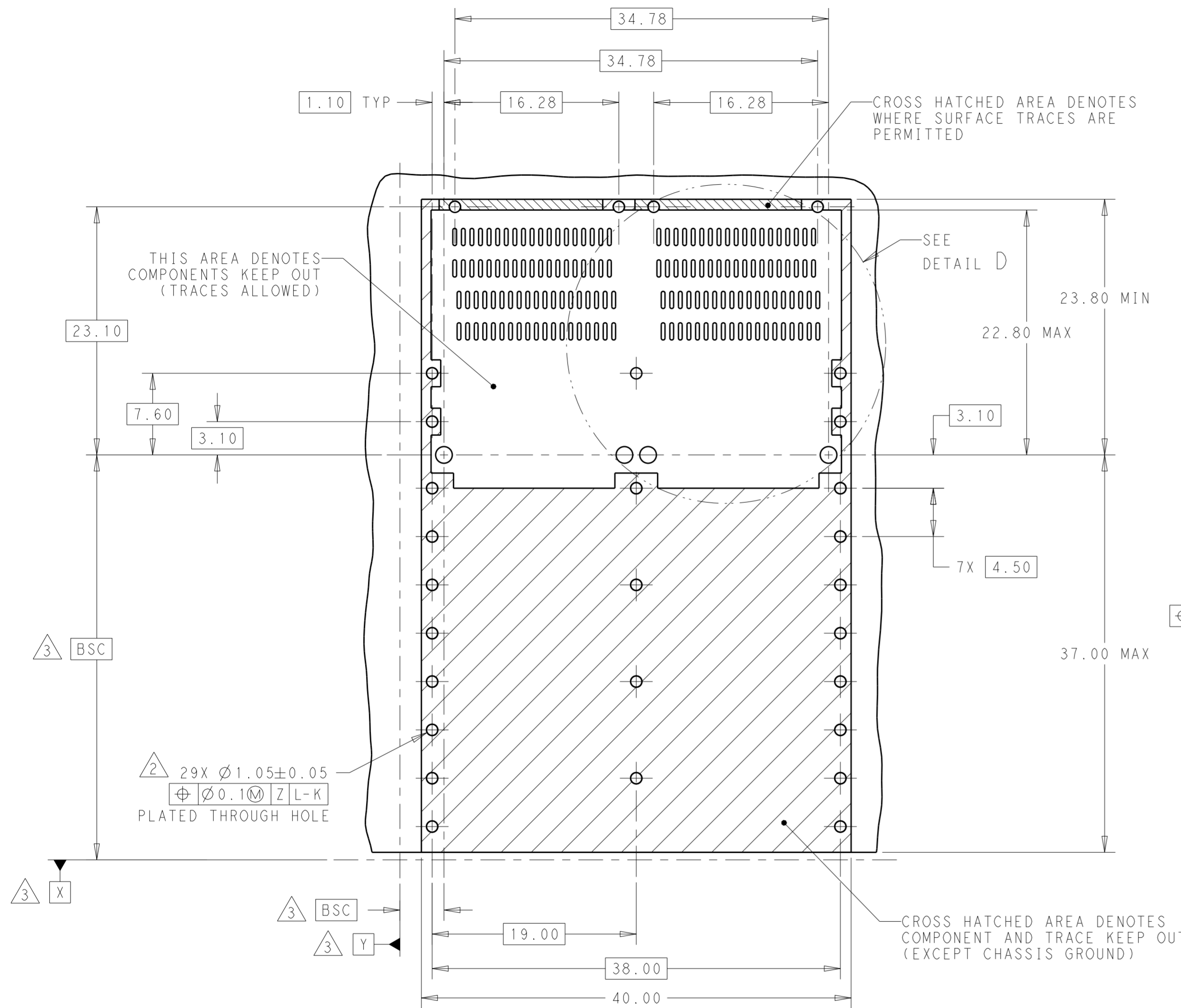

RECOMMENDED PCB LAYOUT
 BELLY TO BELLY
 SCALE 3:1

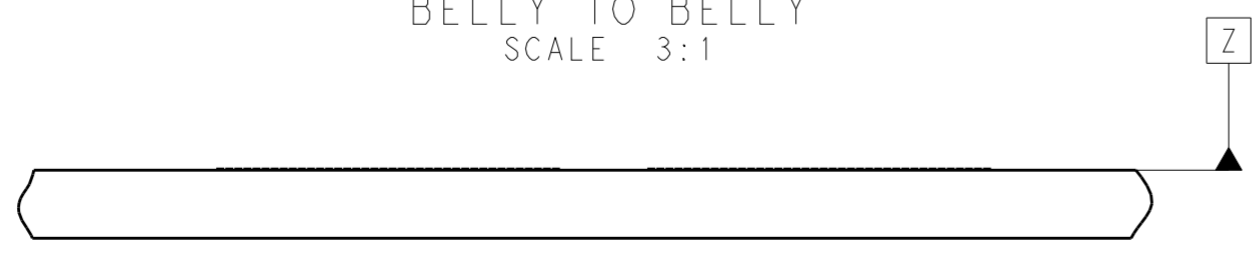

| | | | | |
|--|--------------------|-------------------------------|------------------------------------|--------------------|
| THIS DRAWING IS A CONTROLLED DOCUMENT. | | DWN 21NOV2017 ARTHUR JIN | TE Connectivity | |
| DIMENSIONS: mm | | CHK 21NOV2017 SEAN HAN | | |
| TOLERANCES UNLESS OTHERWISE SPECIFIED: | | APVD 21NOV2017 SEAN HAN | NAME QSFP-DD, 1X2 CAGE ASSEMBLY | |
| 0 PLC ±0.25 | 1 PLC ±0.25 | PRODUCT SPEC 108-60122 | WITH EMI SPRING, HEAT SINK | |
| 2 PLC ±0.20 | 3 PLC ±0.10 | APPLICATION SPEC 114-60025 | SIZE A2 | CAGE CODE - |
| 4 PLC ± | ANGLES ± | WEIGHT - | DRAWING NO C-2328508 | RESTRICTED TO - |
| MATERIAL SEE NOTE | FINISH SEE NOTE | CUSTOMER DRAWING | SCALE 1:1 | SHEET 7 OF 7 |
| | | | REV A2 | |