

USB-B-S-X-X-TH-X-XX

DO NOT SCALE FROM THIS PRINT

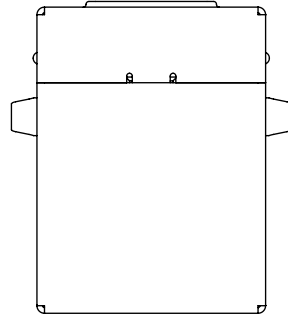

- TYPE
-B
- CONFIGURATION
-S: SINGLE
- PLATING SPECIFICATION
-F: 3µ" SELECTIVE GOLD IN MATTE AREA, MATTE TIN ON TAIL.
-S: 30µ" SELECTIVE GOLD IN MATTE AREA, MATTE TIN ON TAIL.
- PACKAGING
BLANK: TRAY (SEE NOTE 3)
-TR: TAPE & REEL (SEE NOTES 3 & 4)
-FR: FULL REEL QTY TAPE & REEL (SEE NOTES 3 & 4)
- E&I OPTION
-R: RoHS COMPLIANT (SEE NOTE 2)
- TERMINATION
-TH: THRU HOLE
- COLOR
-B: BLACK
-W: WHITE

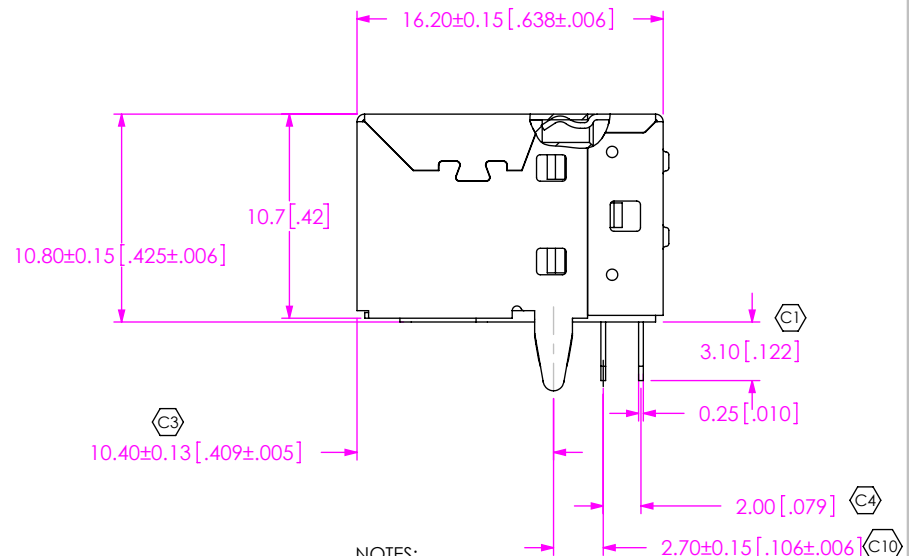
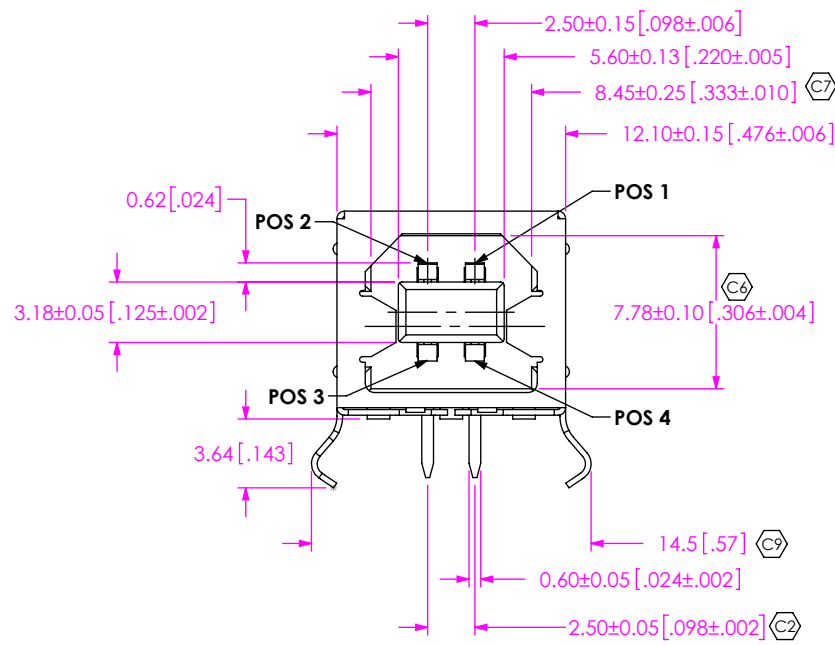
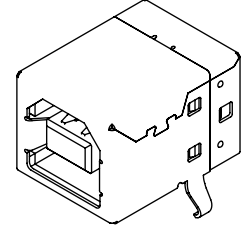

- NOTES:
1. Ⓢ REPRESENTS A CRITICAL DIMENSION.
 2. ALL PARTS ARE RoHS COMPLIANT WITH OR WITHOUT -R.
 3. ORDERS WILL BE PACKAGED ACCORDING TO THE SAMTEC PACKAGING EFFICIENCY STANDARDS (SPES) FOUND ON WWW.SAMTEC.COM
 4. ATTACH LABEL TO EACH REEL.
 5. TRAYS ARE STANDARD PACKAGING.

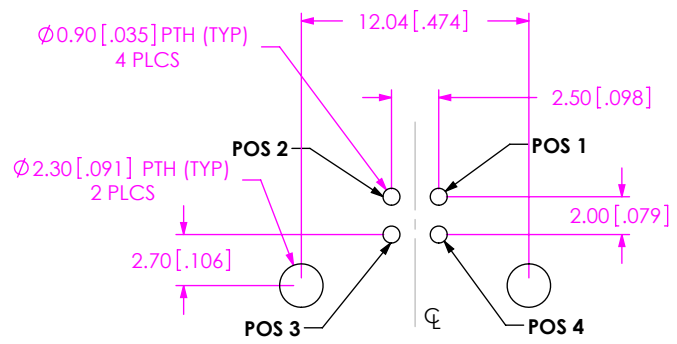

RECOMMENDED PCB LAYOUT

UNLESS OTHERWISE SPECIFIED, DIMENSIONS ARE IN MILLIMETERS.
TOLERANCES ARE:
DECIMALS ANGLES
X.X: ±0.3 [.01] 2°
X.XX: ±0.20 [.008]
X.XXX: ±0.051 [.0020]

PROPRIETARY NOTE
THIS DOCUMENT CONTAINS CONFIDENTIAL AND PROPRIETARY INFORMATION AND ALL DESIGN, MANUFACTURING, REPRODUCTION, USE, PATENT RIGHTS AND SALES RIGHTS ARE EXPRESSLY RESERVED BY SAMTEC, INC. THIS DOCUMENT SHALL NOT BE DISCLOSED, IN WHOLE OR PART, TO ANY UNAUTHORIZED PERSON OR ENTITY NOR REPRODUCED, TRANSFERRED OR INCORPORATED IN ANY OTHER PROJECT IN ANY MANNER WITHOUT THE EXPRESS WRITTEN CONSENT OF SAMTEC, INC.



520 PARK EAST BLVD, NEW ALBANY, IN 47150
PHONE: 812-944-6733 FAX: 812-948-5047
e-Mail: info@SAMTEC.com code: 55322

MATERIAL: DO NOT SCALE DRAWING SHEET SCALE: 2:1	DESCRIPTION: USB TYPE B RIGHT ANGLE THRU HOLE
INSULATOR: PBT, UL94-V0 CONTACT: PHOSPHOR BRONZE SHELL: STEEL; NICKEL PLATED	DWG. NO. USB-B-S-X-X-TH-X-XX
	BY: B.HARPENAU 2/06/06 SHEET 1 OF 1