

UM11349

Introduction to BATT-14CEMULATOR 14-cell slider battery pack emulator kit

Rev. 3.1 — 14 June 2022

User manual

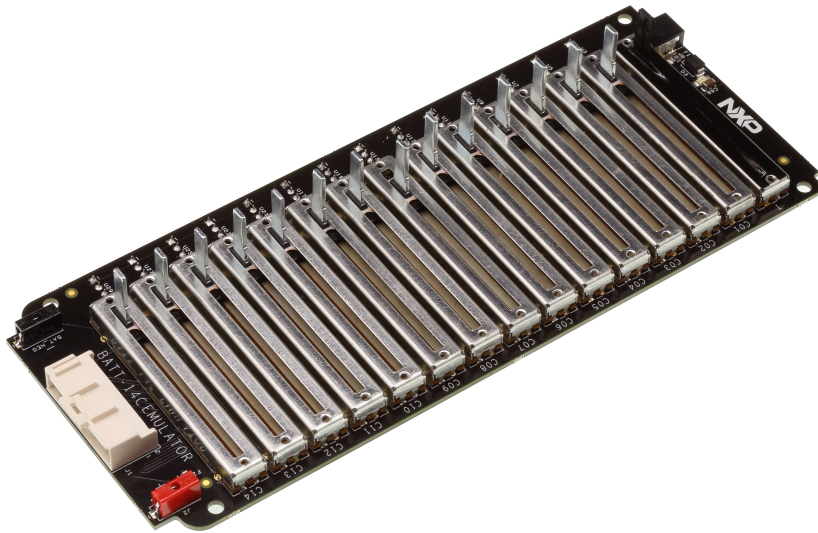

aaa-036424

NXP provides the enclosed product(s) under the following conditions:

This reference design is intended for use of ENGINEERING DEVELOPMENT OR EVALUATION PURPOSES ONLY. It is provided as a sample IC pre-soldered to a printed circuit board to make it easier to access inputs, outputs, and supply terminals. This reference design may be used with any development system or other source of I/O signals by simply connecting it to the host MCU or computer board via off-the-shelf cables. Final device in an application will be heavily dependent on proper printed circuit board layout and heat sinking design as well as attention to supply filtering, transient suppression, and I/O signal quality.

The goods provided may not be complete in terms of required design, marketing, and or manufacturing related protective considerations, including product safety measures typically found in the end product incorporating the goods. Due to the open construction of the product, it is the user's responsibility to take any and all appropriate precautions with regard to electrostatic discharge. In order to minimize risks associated with the customers applications, adequate design and operating safeguards must be provided by the customer to minimize inherent or procedural hazards. For any safety concerns, contact NXP sales and technical support services.

Should this reference design not meet the specifications indicated in the kit, it may be returned within 30 days from the date of delivery and will be replaced by a new kit.

NXP reserves the right to make changes without further notice to any products herein. NXP makes no warranty, representation or guarantee regarding the suitability of its products for any particular purpose, nor does NXP assume any liability arising out of the application or use of any product or circuit, and specifically disclaims any and all liability, including without limitation consequential or incidental damages. "Typical" parameters can and do vary in different applications and actual performance may vary over time. All operating parameters, including "Typical", must be validated for each customer application by customer's technical experts.

NXP does not convey any license under its patent rights nor the rights of others. NXP products are not designed, intended, or authorized for use as components in systems intended for surgical implant into the body, or other applications intended to support or sustain life, or for any other application in which the failure of the NXP product could create a situation where personal injury or death may occur. Should the Buyer purchase or use NXP products for any such unintended or unauthorized application, the Buyer shall indemnify and hold NXP and its officers, employees, subsidiaries, affiliates, and distributors harmless against all claims, costs, damages, and expenses, and reasonable attorney fees arising out of, directly or indirectly, any claim of personal injury or death associated with such unintended or unauthorized use, even if such claim alleges NXP was negligent regarding the design or manufacture of the part.

1 Finding kit resources and information on the NXP web site

NXP Semiconductors provides online resources for this evaluation board and its supported device(s) on <http://www.nxp.com>.

The information page for BATT-14CEMULATOR, 14-cell slider battery pack emulator is at <http://www.nxp.com/products/:BATT-14CEMULATOR>. The information page provides overview information, documentation, software and tools, parametrics, ordering information and a Getting Started tab. The Getting Started tab provides quick-reference information applicable to using the BATT-14CEMULATOR, 14-cell slider battery pack emulator, including the downloadable assets referenced in this document.

1.1 Collaborate in the NXP Community

The NXP Community is for sharing ideas and tips, asking and answering technical questions, and receiving input on just about any embedded design topic.

The NXP Community is at <http://community.nxp.com>.

2 Getting started

2.1 Kit contents

The **BATT-14CEMULATOR** contents include:

- BATT-14CEMULATOR, 14-cell slider battery pack emulator

2.2 Additional hardware

To use this kit, you need:

- Power supply 12 VDC with current capability 1.5 A

3 Getting to know the hardware

3.1 General description: BATT-14CEMULATOR

The BATT-14CEMULATOR board can emulate a multi-cell battery pack that can be easily hooked-up to the evaluation boards for MC33771C battery cell controllers (BCC):

- RD33771CNTREVM
- FRDM33771BSPIEVb

The user can connect the BATT-14CEMULATOR board for a quick evaluation of NXP BCC ICs, or to help the users in their software development. These boards basically provide a very intuitive way to change the voltage across any of the 14 cells of an emulated battery pack as well as the voltage across some analog inputs of the BCC IC that are typically used as temperature sensors.

This product has not undergone formal EU EMC assessment. As a component used in a research environment, it is the responsibility of the user to ensure the finished assembly does not cause undue interference when used and cannot be CE marked unless assessed.

3.2 Features: BATT-14CEMULATOR

- 14 slider potentiometers
- Each slider can modify the cell voltage between 1.25 V and 4.6 V
- Current capability of the cell output voltage is 110 mA
- Up to three evaluation boards can be connected in parallel
- Temperature sensor output voltage can vary from 0 V to +4.95 V
- Two output terminals to allow stack-up of several emulators

3.3 Board functions

These boards have been designed and optimized for the operating conditions described below. Usage of these boards beyond these conditions can lead to malfunction and damage.

Table 1. Maximum ratings

Description	Min	Max	Unit
Supply input voltage	10.8	13.2	V
Cell output current	—	110	mA
Operating ambient temperature	-10	+40	°C

Table 2. Electrical characteristics

Description	Min	Typ	Max	Unit
Minimum cell voltage output (slider down)	—	1.25	—	V
Maximum cell voltage output (slider up)	—	4.9	—	V
Minimum temperature sensor voltage output (slider down)	—	0	—	mV
Maximum temperature sensor voltage output (slider up)	—	4.95	—	mV
Voltage isolation between input power supply and battery emulator outputs	—	1	—	kV

3.4 BATT-14CEMULATOR featured components

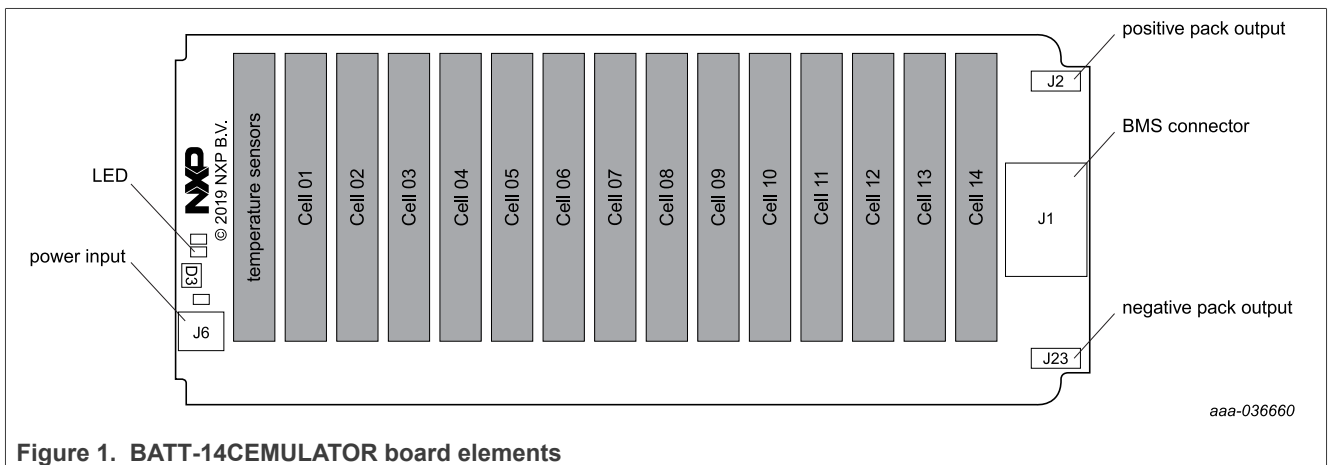

Figure 1. BATT-14CEMULATOR board elements

Introduction to BATT-14CEMULATOR 14-cell slider battery pack emulator kit

The emulator board requires a 12 V DC power supply with 1.5 A current capability. The power supply is to be connected to the board via J6, a Ø3.5 mm jack connector. The center pin is to be connected to the positive voltage and the ring terminal to the ground. The input of the board is protected in case of wrong polarity. An LED allows the user to check that the board is powered up. If the voltage is present to the jack connector but the LED is off, then check the fuse F1.

Each of the sliders allows the user to change independently the differential voltage between two cell terminals (or cell voltage). A separate slider allows the variation of the voltage across the temperature sensors.

Using the slider potentiometers, the user can modify each cell voltage between 1.25 V and 4.6 V. The current capability of the cell output voltage is 110 mA, which allows the user to connect up to three evaluation boards in parallel to the same battery emulator.

The temperature sensor output voltage can vary from 0 V to +4.95 V. It can mimic the temperature variation from -48 °C to 200 °C of a 10 K NTC sensor. Note that this output voltage is connected to four different analog inputs on the BCC IC (GPIO-3) and that each of them has a 6.8 K pull-up resistor to VCOM (5 V typ.).

The emulator board features two output terminals, a red and a black 2 mm banana plug. The plugs can be used to connect several emulator boards in series. The isolation voltage between the power input and the cells is higher than 1000 V. If several emulator boards are connected in series, the voltage of the packs may exceed 75 V. The user has to take adequate precautions related to the high-voltage risks.

3.5 Schematics

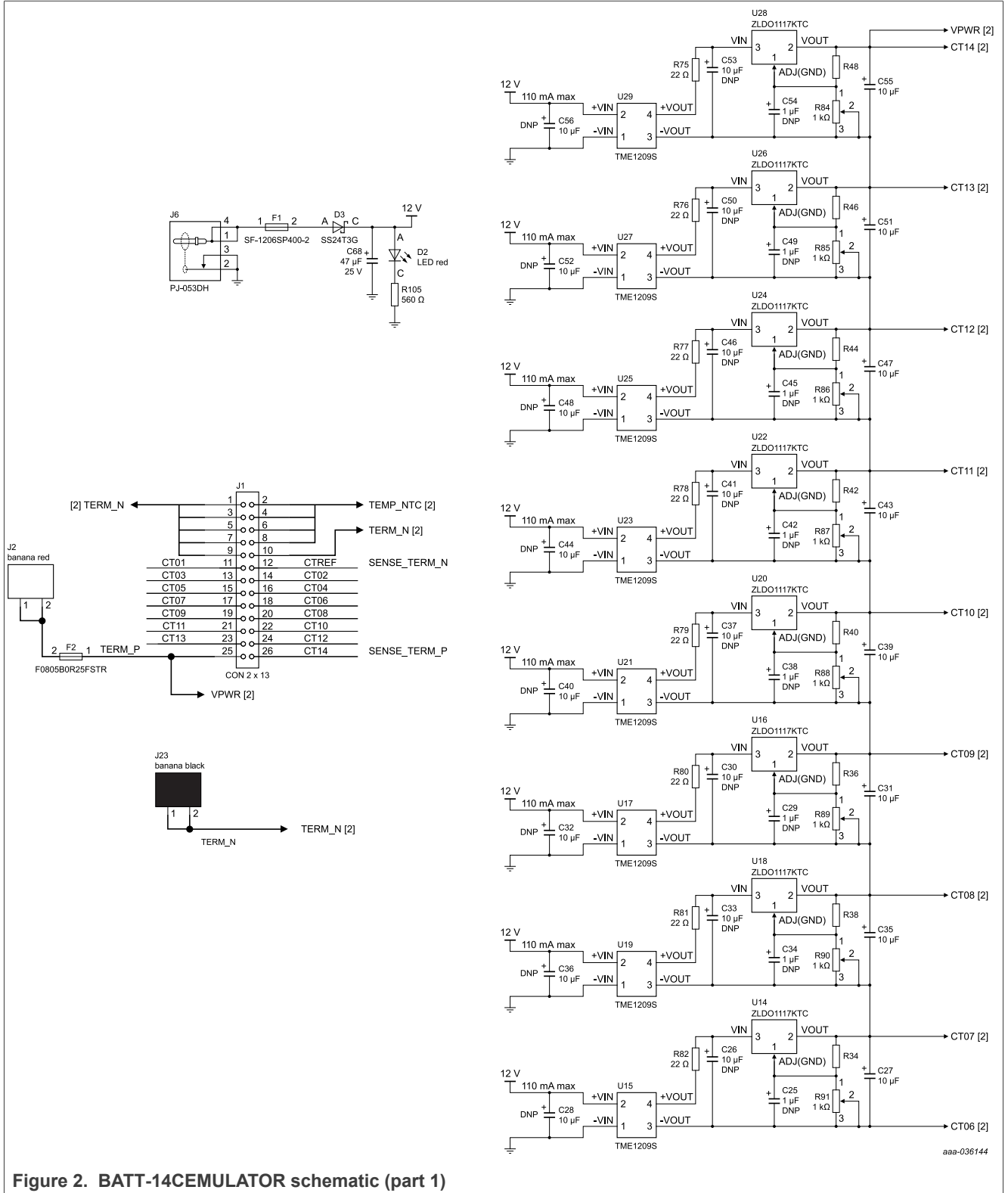
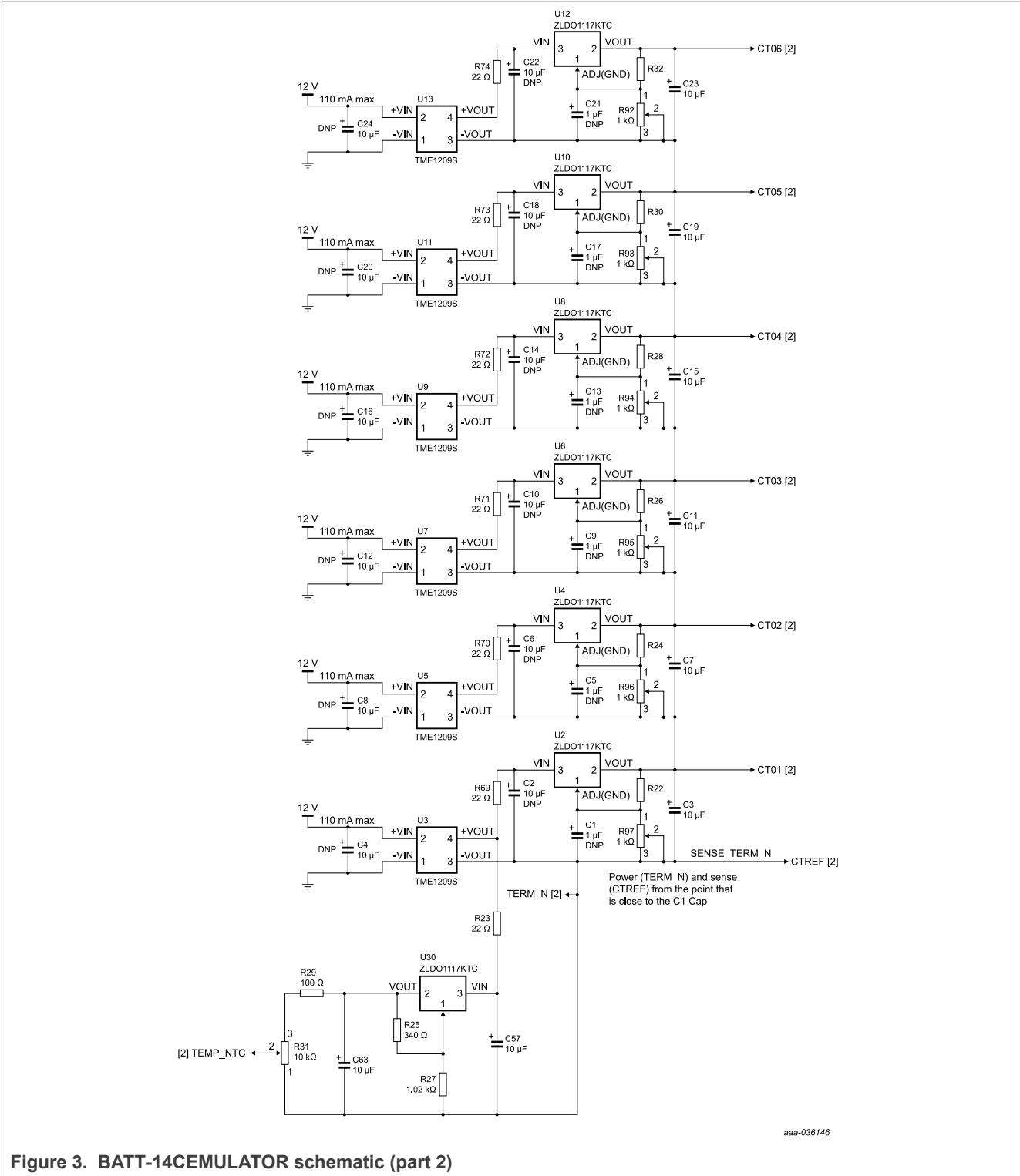

Figure 2. BATT-14CEMULATOR schematic (part 1)

Introduction to BATT-14CEMULATOR 14-cell slider battery pack emulator kit



3.6 Board bill of materials

Table 3. BATT-14CEMULATOR bill of materials

NXP does not assume liability, endorse, or warrant components from external manufacturers are referenced in circuit drawings or tables. While NXP offers component recommendations in this configuration, it is the responsibility of the customer to validate.

Item	Qty	Assembly option	Reference	Value	Manufacturing part number	Description
1	14	DNP	C1,C5,C9,C13,C17,C21,C25,C29,C34,C38,C42,C45,C49,C54	1 μ F		50 V capacitor 1206
2	28	DNP	C2,C4,C6,C8,C10,C12,C14,C16,C18,C20,C22,C24,C26,C28,C30,C32,C33,C36,C37,C40,C41,C44,C46,C48,C50,C52,C53,C56	10 μ F		50 V capacitor 1206
3	14		C3,C7,C11,C15,C19,C23,C27,C31,C35,C39,C43,C47,C51,C55	10 μ F		10 V capacitor 1206
4	2		C57,C58	10 μ F		50 V capacitor 1206
5	1		C68	47 μ F		25 V capacitor 1206
6	1		D2		APT3216SURCK	LED red
7	1		D3	40 V	SS24T3G	diode 2 A 40 V SMB
8	1		F1	4 A	SF-1206SP400-2	fuse 4 A SMD 1206
9	1		F2	0.25 A	F0805B0R25FSTR	fuse 0.25 A SMD 0805
10	1		J1		MOLEX 501876-2640	CON 2X13
11	1		J2		930224101	banana red
12	1		J6		PJ-053DH	PWR jack 1.3 mm
13	1		J23		930224100	banana black
14	15		R22,R24,R25,R26,R28,R30,R32,R34,R36,R38,R40,R42,R44,R46,R48	360 Ω		RES 0.125 W 1 % 0603
15	15		R23,R69,R70,R71,R72,R73,R74,R75,R76,R77,R78,R79,R80,R81,R82	22 Ω		RES 0.25 W 5 % 1206
16	1		R27	1.02 K Ω		RES 0.1 W 1 % 0603
17	1		R29	100 Ω		RES 0.1 W 1 % 0603
18	1		R31	10 K Ω	PTA4553-2215CIB103	RES POT 10 k Ω 0.25 W
19	14		R84,R85,R86,R87,R88,R89,R90,R91,R92,R93,R94,R95,R96,R97	1 k Ω	PTA4543-2015CPB102	RES POT 1 k Ω 0.25 W
20	2		R101, R104	3.3 k Ω		RES 0.1 W 0.1 % 0603
21	1		R105	560 Ω		RES 0.125 W 1 % 0603
22	15		U1,U2,U4,U6,U8,U10,U12,U14,U16,U18,U20,U22,U24,U26,U28		LM2596-ADJ	voltage regulator
23	14		U3,U5,U7,U9,U11,U13,U15,U17,U19,U21,U23,U25,U27,U29		TME1209S	9 V DC-to-DC converter

4 References

The following are URLs where the user can obtain information on related NXP products and application solutions.

Table 4. References

Item	Description	Link
BATT-14CEMULATOR	tool summary page	http://www.nxp.com/BATT-14CEMULATOR
MC33771C	battery cell controllers page	http://www.nxp.com/MC33771C
FRDM33771CSPEVB	evaluation kit	http://www.nxp.com/FRDM33771CSPEVB
RD33771CDSTEVB	evaluation kit	http://www.nxp.com/RD33771CDSTEVB

5 Revision history

Revision history

Revision number	Date	Description
3.1	2022mmdd	<ul style="list-style-type: none"> • Section 4, Changed to FRDM33771CSPEVB from FRDM33771CSPIEBV, two places
3	20220601	<ul style="list-style-type: none"> • Table 3, Item 14: Changed Value to 360 from 340
2	20200128	<ul style="list-style-type: none"> • Section 3.1, added paragraph "This product has not undergone formal EU EMC assessment..." • Updated Figure 1
1	20200110	Initial release

6 Legal information

6.1 Definitions

Draft — A draft status on a document indicates that the content is still under internal review and subject to formal approval, which may result in modifications or additions. NXP Semiconductors does not give any representations or warranties as to the accuracy or completeness of information included in a draft version of a document and shall have no liability for the consequences of use of such information.

6.2 Disclaimers

Limited warranty and liability — Information in this document is believed to be accurate and reliable. However, NXP Semiconductors does not give any representations or warranties, expressed or implied, as to the accuracy or completeness of such information and shall have no liability for the consequences of use of such information. NXP Semiconductors takes no responsibility for the content in this document if provided by an information source outside of NXP Semiconductors.

In no event shall NXP Semiconductors be liable for any indirect, incidental, punitive, special or consequential damages (including - without limitation - lost profits, lost savings, business interruption, costs related to the removal or replacement of any products or rework charges) whether or not such damages are based on tort (including negligence), warranty, breach of contract or any other legal theory.

Notwithstanding any damages that customer might incur for any reason whatsoever, NXP Semiconductors' aggregate and cumulative liability towards customer for the products described herein shall be limited in accordance with the Terms and conditions of commercial sale of NXP Semiconductors.

Right to make changes — NXP Semiconductors reserves the right to make changes to information published in this document, including without limitation specifications and product descriptions, at any time and without notice. This document supersedes and replaces all information supplied prior to the publication hereof.

Applications — Applications that are described herein for any of these products are for illustrative purposes only. NXP Semiconductors makes no representation or warranty that such applications will be suitable for the specified use without further testing or modification.

Customers are responsible for the design and operation of their applications and products using NXP Semiconductors products, and NXP Semiconductors accepts no liability for any assistance with applications or customer product design. It is customer's sole responsibility to determine whether the NXP Semiconductors product is suitable and fit for the customer's applications and products planned, as well as for the planned application and use of customer's third party customer(s). Customers should provide appropriate design and operating safeguards to minimize the risks associated with their applications and products.

NXP Semiconductors does not accept any liability related to any default, damage, costs or problem which is based on any weakness or default in the customer's applications or products, or the application or use by customer's third party customer(s). Customer is responsible for doing all necessary testing for the customer's applications and products using NXP Semiconductors products in order to avoid a default of the applications and the products or of the application or use by customer's third party customer(s). NXP does not accept any liability in this respect.

Suitability for use in automotive applications — This NXP product has been qualified for use in automotive applications. If this product is used by customer in the development of, or for incorporation into, products or services (a) used in safety critical applications or (b) in which failure could lead to death, personal injury, or severe physical or environmental damage (such products and services hereinafter referred to as "Critical Applications"), then customer makes the ultimate design decisions regarding its products and is solely responsible for compliance with all legal, regulatory, safety, and security related requirements concerning its products, regardless of any information or support that may be provided by NXP. As such, customer assumes all risk related to use of any products in Critical Applications and NXP and its suppliers shall not be liable for any such use by customer. Accordingly, customer will indemnify and hold NXP harmless from any claims, liabilities, damages and associated costs and expenses (including attorneys' fees) that NXP may incur related to customer's incorporation of any product in a Critical Application.

Export control — This document as well as the item(s) described herein may be subject to export control regulations. Export might require a prior authorization from competent authorities.

Evaluation products — This product is provided on an "as is" and "with all faults" basis for evaluation purposes only. NXP Semiconductors, its affiliates and their suppliers expressly disclaim all warranties, whether express, implied or statutory, including but not limited to the implied warranties of non-infringement, merchantability and fitness for a particular purpose. The entire risk as to the quality, or arising out of the use or performance, of this product remains with customer.

In no event shall NXP Semiconductors, its affiliates or their suppliers be liable to customer for any special, indirect, consequential, punitive or incidental damages (including without limitation damages for loss of business, business interruption, loss of use, loss of data or information, and the like) arising out of the use of or inability to use the product, whether or not based on tort (including negligence), strict liability, breach of contract, breach of warranty or any other theory, even if advised of the possibility of such damages.

Notwithstanding any damages that customer might incur for any reason whatsoever (including without limitation, all damages referenced above and all direct or general damages), the entire liability of NXP Semiconductors, its affiliates and their suppliers and customer's exclusive remedy for all of the foregoing shall be limited to actual damages incurred by customer based on reasonable reliance up to the greater of the amount actually paid by customer for the product or five dollars (US\$5.00). The foregoing limitations, exclusions and disclaimers shall apply to the maximum extent permitted by applicable law, even if any remedy fails of its essential purpose.

Safety of high-voltage evaluation products — The non-insulated high voltages that are present when operating this product, constitute a risk of electric shock, personal injury, death and/or ignition of fire. This product is intended for evaluation purposes only. It shall be operated in a designated test area by personnel that is qualified according to local requirements and labor laws to work with non-insulated mains voltages and high-voltage circuits.

The product does not comply with IEC 60950 based national or regional safety standards. NXP Semiconductors does not accept any liability for damages incurred due to inappropriate use of this product or related to non-insulated high voltages. Any use of this product is at customer's own risk and liability. The customer shall fully indemnify and hold harmless NXP Semiconductors from any liability, damages and claims resulting from the use of the product.

Translations — A non-English (translated) version of a document, including the legal information in that document, is for reference only. The English version shall prevail in case of any discrepancy between the translated and English versions.

6.3 Trademarks

Notice: All referenced brands, product names, service names, and trademarks are the property of their respective owners.

Introduction to BATT-14CEMULATOR 14-cell slider battery pack emulator kit

NXP — wordmark and logo are trademarks of NXP B.V.

SafeAssure — is a trademark of NXP B.V.

Tables

Tab. 1.	Maximum ratings	3	Tab. 3.	BATT-14CEMULATOR bill of materials	7
Tab. 2.	Electrical characteristics	3	Tab. 4.	References	8

Figures

Fig. 1.	BATT-14CEMULATOR board elements	3	Fig. 3.	BATT-14CEMULATOR schematic (part 2)	6
Fig. 2.	BATT-14CEMULATOR schematic (part 1)	5			

Contents

1	Finding kit resources and information on the NXP web site	2
1.1	Collaborate in the NXP Community	2
2	Getting started	2
2.1	Kit contents	2
2.2	Additional hardware	2
3	Getting to know the hardware	2
3.1	General description: BATT-14CEMULATOR	2
3.2	Features: BATT-14CEMULATOR	3
3.3	Board functions	3
3.4	BATT-14CEMULATOR featured components	3
3.5	Schematics	5
3.6	Board bill of materials	7
4	References	8
5	Revision history	8
6	Legal information	9

Please be aware that important notices concerning this document and the product(s) described herein, have been included in section 'Legal information'.
