



Please note that Cypress is an Infineon Technologies Company.

The document following this cover page is marked as “Cypress” document as this is the company that originally developed the product. Please note that Infineon will continue to offer the product to new and existing customers as part of the Infineon product portfolio.

Continuity of document content

The fact that Infineon offers the following product as part of the Infineon product portfolio does not lead to any changes to this document. Future revisions will occur when appropriate, and any changes will be set out on the document history page.

Continuity of ordering part numbers

Infineon continues to support existing part numbers. Please continue to use the ordering part numbers listed in the datasheet for ordering.



CY8CKIT-042

PSoC 4 Pioneer Kit Guide

Doc. # 001-86371 Rev. *K

Cypress Semiconductor
198 Champion Court
San Jose, CA 95134-1709
www.cypress.com

Copyrights

© Cypress Semiconductor Corporation, 2013–2019. This document is the property of Cypress Semiconductor Corporation and its subsidiaries, including Spansion LLC ("Cypress"). This document, including any software or firmware included or referenced in this document ("Software"), is owned by Cypress under the intellectual property laws and treaties of the United States and other countries worldwide. Cypress reserves all rights under such laws and treaties and does not, except as specifically stated in this paragraph, grant any license under its patents, copyrights, trademarks, or other intellectual property rights. If the Software is not accompanied by a license agreement and you do not otherwise have a written agreement with Cypress governing the use of the Software, then Cypress hereby grants you a personal, non-exclusive, nontransferable license (without the right to sublicense) (1) under its copyright rights in the Software (a) for Software provided in source code form, to modify and reproduce the Software solely for use with Cypress hardware products, only internally within your organization, and (b) to distribute the Software in binary code form externally to end users (either directly or indirectly through resellers and distributors), solely for use on Cypress hardware product units, and (2) under those claims of Cypress's patents that are infringed by the Software (as provided by Cypress, unmodified) to make, use, distribute, and import the Software solely for use with Cypress hardware products. Any other use, reproduction, modification, translation, or compilation of the Software is prohibited.

TO THE EXTENT PERMITTED BY APPLICABLE LAW, CYPRESS MAKES NO WARRANTY OF ANY KIND, EXPRESS OR IMPLIED, WITH REGARD TO THIS DOCUMENT OR ANY SOFTWARE OR ACCOMPANYING HARDWARE, INCLUDING, BUT NOT LIMITED TO, THE IMPLIED WARRANTIES OF MERCHANTABILITY AND FITNESS FOR A PARTICULAR PURPOSE. No computing device can be absolutely secure. Therefore, despite security measures implemented in Cypress hardware or software products, Cypress does not assume any liability arising out of any security breach, such as unauthorized access to or use of a Cypress product. In addition, the products described in these materials may contain design defects or errors known as errata which may cause the product to deviate from published specifications. To the extent permitted by applicable law, Cypress reserves the right to make changes to this document without further notice.

Cypress does not assume any liability arising out of the application or use of any product or circuit described in this document. Any information provided in this document, including any sample design information or programming code, is provided only for reference purposes. It is the responsibility of the user of this document to properly design, program, and test the functionality and safety of any application made of this information and any resulting product. Cypress products are not designed, intended, or authorized for use as critical components in systems designed or intended for the operation of weapons, weapons systems, nuclear installations, life-support devices or systems, other medical devices or systems (including resuscitation equipment and surgical implants), pollution control or hazardous substances management, or other uses where the failure of the device or system could cause personal injury, death, or property damage ("Unintended Uses"). A critical component is any component of a device or system whose failure to perform can be reasonably expected to cause the failure of the device or system, or to affect its safety or effectiveness. Cypress is not liable, in whole or in part, and you shall and hereby do release Cypress from any claim, damage, or other liability arising from or related to all Unintended Uses of Cypress products. You shall indemnify and hold Cypress harmless from and against all claims, costs, damages, and other liabilities, including claims for personal injury or death, arising from or related to any Unintended Uses of Cypress products.

Cypress, the Cypress logo, Spansion, the Spansion logo, and combinations thereof, WICED, PSoC, CapSense, EZ-USB, F-RAM, and Traveo are trademarks or registered trademarks of Cypress in the United States and other countries. For a more complete list of Cypress trademarks, visit cypress.com. Other names and brands may be claimed as property of their respective owners.

PSoC Designer, PSoC Creator, SmartSense, and CapSense Express are trademarks of Cypress Semiconductor Corporation.

Contents



Safety Information	5
1. Introduction	7
1.1 Kit Contents	7
1.2 PSoC Creator™	9
1.3 Getting Started.....	9
1.4 Additional Learning Resources	10
1.4.1 PSoC Creator.....	11
1.4.2 PSoC Creator Code Examples	12
1.4.3 PSoC Creator Help	12
1.4.4 Technical Support.....	13
1.5 Documentation Conventions.....	13
2. Software Installation	14
2.1 Install Kit Software	14
2.2 Uninstall Software	16
3. Kit Operation	17
3.1 KitProg USB Connection	18
3.2 Programming and Debugging PSoC 4	19
3.2.1 Using the Onboard PSoC 5LP Programmer and Debugger	19
3.2.2 Using CY8CKIT-002 MiniProg3 Programmer and Debugger.....	21
3.3 USB-UART Bridge	22
3.4 USB-I2C Bridge	24
3.5 Updating the Onboard Programmer Firmware	25
4. Hardware	27
4.1 Board Details	27
4.2 Theory of Operation.....	29
4.3 Functional Description	30
4.3.1 PSoC 4.....	30
4.3.2 PSoC 5LP	31
4.3.3 Power Supply System.....	33
4.3.4 Programming Interface.....	35
4.3.5 Arduino Compatible Headers (J1, J2, J3, J4, and J12 - unpopulated).....	36
4.3.6 Digilent Pmod Compatible Header (J5 - unpopulated).....	38
4.3.7 PSoC 5LP GPIO Header (J8)	39
4.3.8 CapSense Slider	40
4.3.9 Pioneer Board LEDs	41
4.3.10 Push Buttons.....	42

5. Code Examples	43
5.1 Using the Kit Code Examples	43
5.2 Blinking LED	46
5.2.1 Project Description	46
5.2.2 Hardware Connections.....	46
5.2.3 Flow Chart.....	47
5.2.4 Verify Output	47
5.3 PWM.....	48
5.3.1 Project Description	48
5.3.2 Hardware Connections.....	48
5.3.3 Flow Chart.....	49
5.3.4 Verify Output	49
5.4 Deep Sleep	50
5.4.1 Project Description	50
5.4.2 Hardware Connections.....	50
5.4.3 Flow Chart.....	52
5.4.4 Verify Output	52
5.5 CapSense	53
5.5.1 CapSense (Without Tuning).....	53
5.5.2 CapSense (With Tuning).....	56
6. Advanced Topics	64
6.1 Using PSoC 5LP as a USB-UART Bridge	64
6.2 Using PSoC 5LP as USB-I2C Bridge	78
6.3 Developing Applications for PSoC 5LP	87
6.3.1 Building a Bootloadable Project for PSoC 5LP	87
6.3.2 Building a Normal Project for PSoC 5LP.....	96
6.4 PSoC 5LP Factory Program Restore Instructions	99
6.4.1 PSoC 5LP is Programmed with a Bootloadable Application	99
6.4.2 PSoC 5LP is Programmed with a Standard Application.....	104
A. Appendix	107
A.1 CY8CKIT-042 Schematics.....	107
A.2 Pin Assignment Table.....	111
A.3 Program and Debug Headers.....	114
A.4 Use of Zero-ohm Resistors and No Load	115
A.5 Error in Firmware/Status Indication in Status LED	115
A.6 Bill of Materials (BOM).....	116
A.7 Regulatory Compliance Information	118
A.8 Migrating projects across different Pioneer series kits	119
Revision History	123

Safety Information



Regulatory Compliance

The CY8CKIT-042 PSoC[®] 4 Pioneer Kit is intended for use as a development platform for hardware or software in a laboratory environment. The board is an open system design, which does not include a shielded enclosure. Due to this reason, the board may cause interference to other electrical or electronic devices in close proximity. In a domestic environment, this product may cause radio interference. In such cases, the user may be required to take adequate preventive measures. Also, this board should not be used near any medical equipment or RF devices.

Attaching additional wiring to this product or modifying the product operation from the factory default may affect its performance and cause interference with other apparatus in the immediate vicinity. If such interference is detected, suitable mitigating measures should be taken.

The CY8CKIT-042 as shipped from the factory has been verified to meet with requirements of CE as a Class A product.



The CY8CKIT-042 contains electrostatic discharge (ESD) sensitive devices. Electrostatic charges readily accumulate on the human body and any equipment, and can discharge without detection. Permanent damage may occur on devices subjected to high-energy discharges. Proper ESD precautions are recommended to avoid performance degradation or loss of functionality. Store unused CY8CKIT-042 boards in the protective shipping package.



End-of-Life/Product Recycling

This kit has an end-of-life cycle five years from the date of manufacturing mentioned on the back of the box. Contact your nearest recycler for discarding the kit.

General Safety Instructions

ESD Protection

ESD can damage boards and associated components. Cypress recommends that the user perform procedures only at an ESD workstation. If an ESD workstation is not available, use appropriate ESD protection by wearing an antistatic wrist strap attached to the chassis ground (any unpainted metal surface) on the board when handling parts.

Handling Boards

CY8CKIT-042 boards are sensitive to ESD. Hold the board only by its edges. After removing the board from its box, place it on a grounded, static free surface. Use a conductive foam pad if available. Do not slide board over any surface.

1. Introduction



Thank you for your interest in the PSoC[®] 4 Pioneer Kit. The kit is designed as an easy-to-use and inexpensive development kit, showcasing the unique flexibility of the PSoC 4 architecture. Designed for flexibility, this kit offers footprint-compatibility with several third-party Arduino[™] shields. This kit has a provision to populate an extra header to support Digilent[®] Pmod[™] peripheral modules. In addition, the board features a CapSense[®] slider, an RGB LED, a push button switch, an integrated USB programmer, a program and debug header, and USB-UART/I2C bridges. This kit supports either 5 V or 3.3 V as power supply voltages.

The PSoC 4 Pioneer Kit is based on the PSoC 4200 device family, delivering a programmable platform for a wide range of embedded applications. The PSoC 4 is a scalable and reconfigurable platform architecture for a family of mixed-signal programmable embedded system controllers with an Arm[®] Cortex[™]-M0 CPU. It combines programmable and reconfigurable analog and digital blocks with flexible automatic routing.

1.1 Kit Contents

The CY8CKIT-042 PSoC 4 Pioneer Kit contains:

- PSoC 4 Pioneer board
- Quick Start Guide
- USB Standard-A to Mini-B cable
- Six jumper wires

Figure 1-1. Kit Contents

CY8CKIT-042 PSoC® 4 PIONEER KIT

CYPRESS PROGRAMMABLE SYSTEM-ON-CHIP SOLUTION

CY8CKIT-042 PSoC® 4 PIONEER KIT

Featuring:

- The most flexible and lowest power Arm® Cortex™-M0 Solution
- Cypress's industry-leading CapSense® technology
- Arduino™ Shield compatible expansion ports

PSoC Architectures Supported:

1

3

4

5

www.cypress.com/PSoC4

CY8CKIT-042 QUICK START GUIDE

PSoC® 4 PIONEER KIT

1

Download and install the latest kit software and examples from www.cypress.com/CY8CKIT-042

2

Connect the board to your computer using the provided USB cable

3

Blue LED Blinks

4

Design with PSoC® Creator™



Inspect the contents of the kit; if you find any part missing, contact your nearest Cypress sales office for help: www.cypress.com/support.

1.2 PSoC Creator™

PSoC Creator is a state-of-the-art, easy-to-use integrated design environment (IDE). It introduces revolutionary hardware and software co-design, powered by a library of pre-verified and pre-characterized PSoC Components™.

With PSoC Creator, you can:

- Drag and drop PSoC components to build a schematic of your custom design
- Automatically place and route components and configure GPIOs
- Develop and debug firmware using the included component APIs

PSoC Creator also enables you to tap into an entire tools ecosystem with integrated compiler chains and production programmers for PSoC devices.

For more information, visit www.cypress.com/creator.

1.3 Getting Started

This guide helps you to get acquainted with the PSoC 4 Pioneer Kit.

- The [Software Installation chapter on page 14](#) describes the installation of the kit software.
- The [Kit Operation chapter on page 17](#) explains how to program the PSoC 4 with a programmer and debugger – either the onboard PSoC 5LP or the external MiniProg3 (CY8CKIT-002).
- The [Hardware chapter on page 27](#) details the hardware operation.
- The [Code Examples chapter on page 43](#) describes the code examples.
- The [Advanced Topics chapter on page 64](#) deals with topics such as building projects for PSoC 5LP, USB-UART functionality, and USB-I2C functionality of PSoC 5LP.
- The [Appendix on page 107](#) provides the schematics, pin assignment, use of zero-ohm resistors, troubleshooting, and the bill of materials (BOM).

1.4 Additional Learning Resources

Cypress provides a wealth of data at www.cypress.com to help you to select the right PSoC device for your design, and to help you to quickly and effectively integrate the device into your design. For a comprehensive list of resources, see [KBA86521](#), [How to Design with PSoC 3](#), [PSoC 4](#), and [PSoC 5LP](#). The following is an abbreviated list for PSoC 4:

- **Overview:** [PSoC Portfolio](#), [PSoC Roadmap](#)
- **Product Selectors:** [PSoC 1](#), [PSoC 3](#), [PSoC 4](#), or [PSoC 5LP](#). In addition, PSoC Creator includes a device selection tool.
- **Datasheets:** Describe and provide electrical specifications for the [PSoC 4000](#), [PSoC 4100](#), and [PSoC 4200](#) device families.
- **CapSense Design Guide:** Learn how to design capacitive touch-sensing applications with the PSoC 4 family of devices.
- **Application Notes and Code Examples:** Cover a broad range of topics, from basic to advanced level. Many of the application notes include code examples. Visit the [PSoC 3/4/5 Code Examples](#) webpage for a list of all available PSoC Creator code examples. For accessing code examples from within PSoC Creator – see [PSoC Creator Code Examples on page 12](#).
- **Technical Reference Manuals (TRM):** Provide detailed descriptions of the architecture and registers in each PSoC 4 device family.
- **Development Kits:**
 - [CY8CKIT-042](#) and [CY8CKIT-040](#), PSoC 4 Pioneer Kits, are easy-to-use and inexpensive development platforms. These kits include connectors for Arduino compatible shields and Digilent Pmod daughter cards.
 - [CY8CKIT-049](#) is a very low-cost prototyping platform for sampling PSoC 4 devices.
 - [CY8CKIT-001](#) is a common development platform for all PSoC family devices.
- The [MiniProg3](#) device provides an interface for flash programming and debug.
- **Knowledge Base Articles (KBA):** Provide design and application tips from experts on the devices/kits. For instance, [KBA93541](#), explains how to use [CY8CKIT-049](#) to program another PSoC 4.
- For a list of trainings on PSoC Creator, visit www.cypress.com/training.

1.4.1 PSoC Creator

PSoC Creator is a free Windows-based integrated design environment (IDE). It enables concurrent hardware and firmware design of systems based on PSoC 3, PSoC 4, and PSoC 5LP. See [Figure 1-2](#) – with PSoC Creator, you can:

1. Drag and drop Components to build your hardware system design in the main design workspace
2. Co-design your application firmware with the PSoC hardware
3. Configure Components using configuration tools
4. Explore the library of 100+ Components
5. Access Component datasheets

Figure 1-2. PSoC Creator Features

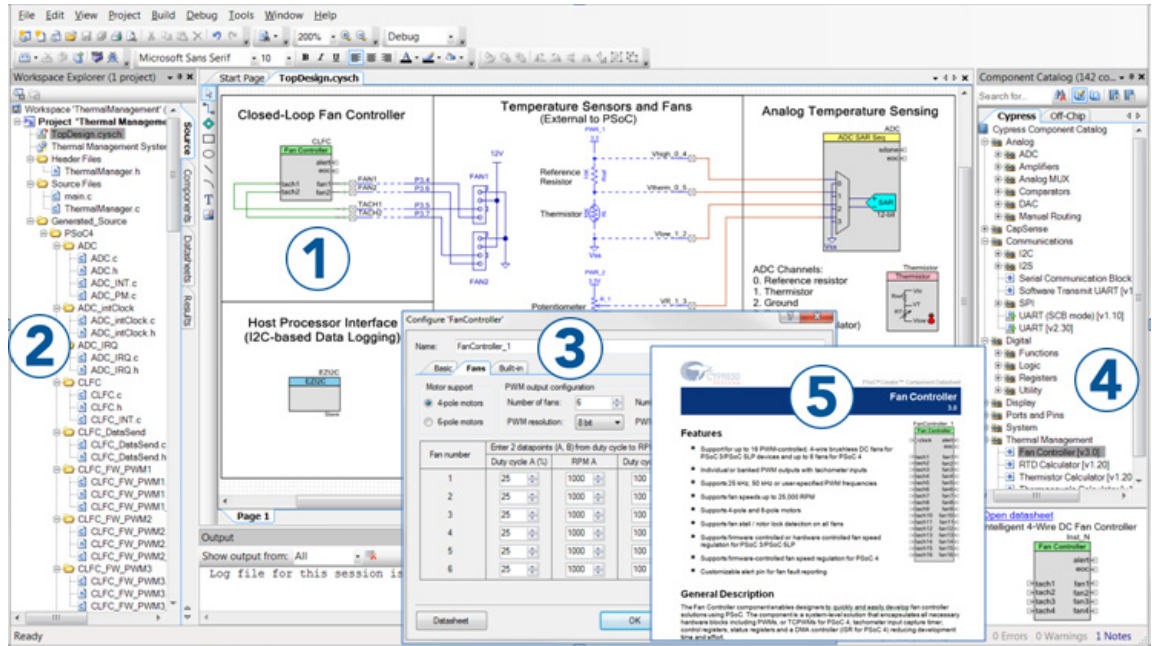

Visit [PSoC Creator training page](#) for video tutorials on learning and using PSoC Creator.

1.4.2 PSoC Creator Code Examples

PSoC Creator includes a large number of code examples. These examples are accessible from the PSoC Creator Start Page, as [Figure 1-3](#) shows.

Code examples can speed up your design process by starting you off with a complete design, instead of a blank page. They also show how PSoC Creator Components can be used for various applications.

In the **Find Code Example** dialog, you have several options:

- Filter for examples based on device family or keyword.
- Select from the list of examples offered based on the **Filter Options**.
- View the project documentation for the selection (on the **Documentation** tab).
- View the code for the selection on the **Sample Code** tab. You can copy the code from this window and paste to your project, which can help speed up code development.
- Create a new workspace for the code example or add to your existing workspace. This can speed up your design process by starting you off with a complete, basic design. You can then adapt that design to your application.

Figure 1-3. Code Examples in PSoC Creator

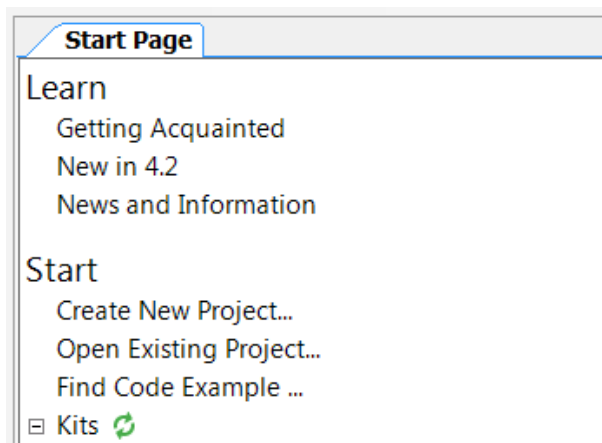

1.4.3 PSoC Creator Help

Visit the [PSoC Creator home page](#) to download the latest version of PSoC Creator. Then, launch PSoC Creator and navigate to the following items:

- **Quick Start Guide:** Choose **Help > Documentation > Quick Start Guide**. This guide gives you the basics for developing PSoC Creator projects.
- **Simple Component Code Examples:** Choose **File > Code Example**. These code examples demonstrate how to configure and use PSoC Creator Components. To access code examples related to a specific Component, place the Component on the TopDesign schematic and right-click on the Component. Select the **Find Code Example** option in the context menu that appears.
- **System Reference Guide:** Choose **Help > System Reference Guide**. This guide lists and describes the system functions provided by PSoC Creator.
- **Component Datasheets:** Right-click a Component and select **Open Datasheet**. Visit the [PSoC 4 Component Datasheets page](#) for a list of all PSoC 4 Component datasheets.

1.4.4 Technical Support

If you have any questions, our technical support team is happy to assist you. You can create a support request on the [Cypress Technical Support](#) page.

If you are in the United States, you can talk to our technical support team by calling our toll-free number: +1-800-541-4736. Select option 3 at the prompt.

You can also use the following support resources if you need quick assistance.

- [Self-help](#)
- [Local Sales Office Locations](#)

1.5 Documentation Conventions

Table 1-1. Document Conventions for Guides

Convention	Usage
Courier New	Displays file locations, user entered text, and source code: C:\ ...cd\icc\
<i>Italics</i>	Displays file names and reference documentation: Read about the <i>sourcefile.hex</i> file in the <i>PSoC Creator User Guide</i> .
[Bracketed, Bold]	Displays keyboard commands in procedures: [Enter] or [Ctrl] [C]
File > Open	Represents menu paths: File > Open > New Project
Bold	Displays commands, menu paths, and icon names in procedures: Click the File icon and then click Open .
Times New Roman	Displays an equation: $2 + 2 = 4$
Text in gray boxes	Describes cautions or unique functionality of the product.

2. Software Installation



2.1 Install Kit Software

Follow these steps to install the CY8CKIT-042 PSoC 4 Pioneer Kit software:

1. Download the kit software from www.cypress.com/CY8CKIT-042. The kit software is available for download in three formats.
 - a. **CY8CKIT-042 Kit Complete Setup**: This installation package contains the files related to the kit including PSoC Creator and PSoC Programmer. However, it does not include the Windows Installer or Microsoft .NET framework packages. If these packages are not on your computer, the installer directs you to download and install them from the Internet.
 - b. **CY8CKIT-042 Kit Only**: This executable file installs only the kit contents, which include kit code examples, hardware files, and user documents. This package can be used if all the software prerequisites (listed in [step 5](#)) are installed on your computer.
 - c. **CY8CKIT-042 DVD ISO**: This file is a complete package, stored in a DVD-ROM image format, which you can use to create a DVD or extract using an ISO extraction program such as WinZip[®] or WinRAR. The file can also be mounted similar to a virtual CD/DVD using virtual drive programs such as Virtual CloneDrive and MagicISO. This file includes all the required software, utilities, drivers, hardware files, and user documents.
2. If you have downloaded the ISO file, mount it in a virtual drive. Extract the ISO contents if you do not have a virtual drive to mount. Double-click *cyautorun.exe* in the root directory of the extracted content or mounted ISO if "Autorun from CD/DVD" is not enabled on the computer. The installation window will appear automatically.

Note: If you are using the "Kit Complete Setup" or "Kit Only" file, then go to [step 4](#) for installation.

- Click **Install CY8CKIT-042 PSoC 4 Pioneer Kit** to start the kit installation, as shown in [Figure 2-1](#).

Figure 2-1. Kit Installer Screen



- Select the directory in which you want to install the files related to the CY8CKIT-042 PSoC 4 Pioneer Kit. Choose the directory and click **Next**.
- The CY8CKIT-042 PSoC 4 Pioneer Kit installer automatically installs the required software, if it is not present on your computer. Following are the required software:
 - PSoC Creator 4.2 or later: This software is also available at www.cypress.com/psoccreator.
 - PSoC Programmer 3.27.1 or later: This is installed as part of PSoC Creator installation (www.cypress.com/programmer).
- Choose the **Typical**, **Custom**, or **Complete** installation type (select **Typical** if you do not know which one to select) in the Product Installation Overview window, as shown in [Figure 2-2](#). Click **Next** after you select the installation type.

Figure 2-2. Product Installation Overview

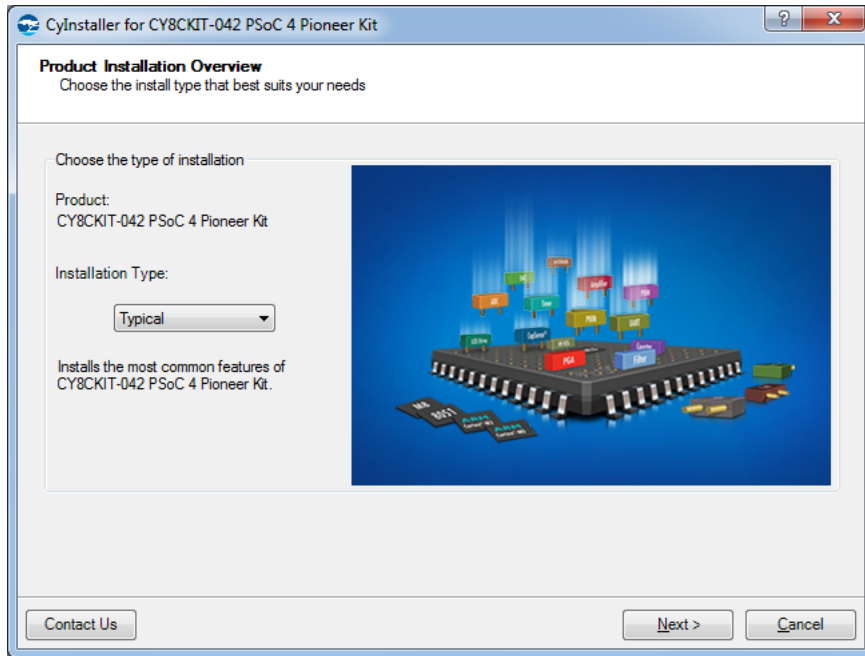

7. Read the License agreement and select **I accept the terms in the license agreement** to continue with the installation. Click **Next**.
8. When the installation begins, a list of packages appears on the installation page. A green check mark appears next to each package after successful installation.
9. Enter your contact information or select the **Continue Without Contact Information** check box. Click **Finish** to complete the kit installation.
10. After the installation is complete, the kit contents are available at the following location:
`<Install_Directory>\CY8CKIT-042 PSoC 4 Pioneer Kit`

Default location:

Windows OS (64-bit):

`C:\Program Files (x86)\Cypress\CY8CKIT-042 PSoC 4 Pioneer Kit`

Windows OS (32-bit):

`C:\Program Files\Cypress\CY8CKIT-042 PSoC 4 Pioneer Kit`

Note: For Windows 7/8/8.1/10 users, the installed files and the folder are read-only. To use the installed code examples, follow the steps outlined in the [Code Examples chapter on page 43](#). These steps will create an editable copy of the example in a path that you choose, so the original installed example is not modified.

2.2 Uninstall Software

The software can be uninstalled using one of the following methods:

1. Go to **Start > All Programs > Cypress > Cypress Update Manager** and select the **Uninstall** button next to the product that needs to be uninstalled.
2. Go to **Start > Control Panel > Programs and Features** for Windows 7 or **Add/Remove Programs** for Windows XP and select the **Uninstall** button.

3. Kit Operation



The PSoC 4 Pioneer Kit can be used to develop applications using the PSoC 4 family of devices and the Arduino shields and Digilent Pmod daughter cards. Figure 3-1 is an image of the PSoC 4 Pioneer board with a markup of the onboard components.

Figure 3-1. PSoC 4 Pioneer Board

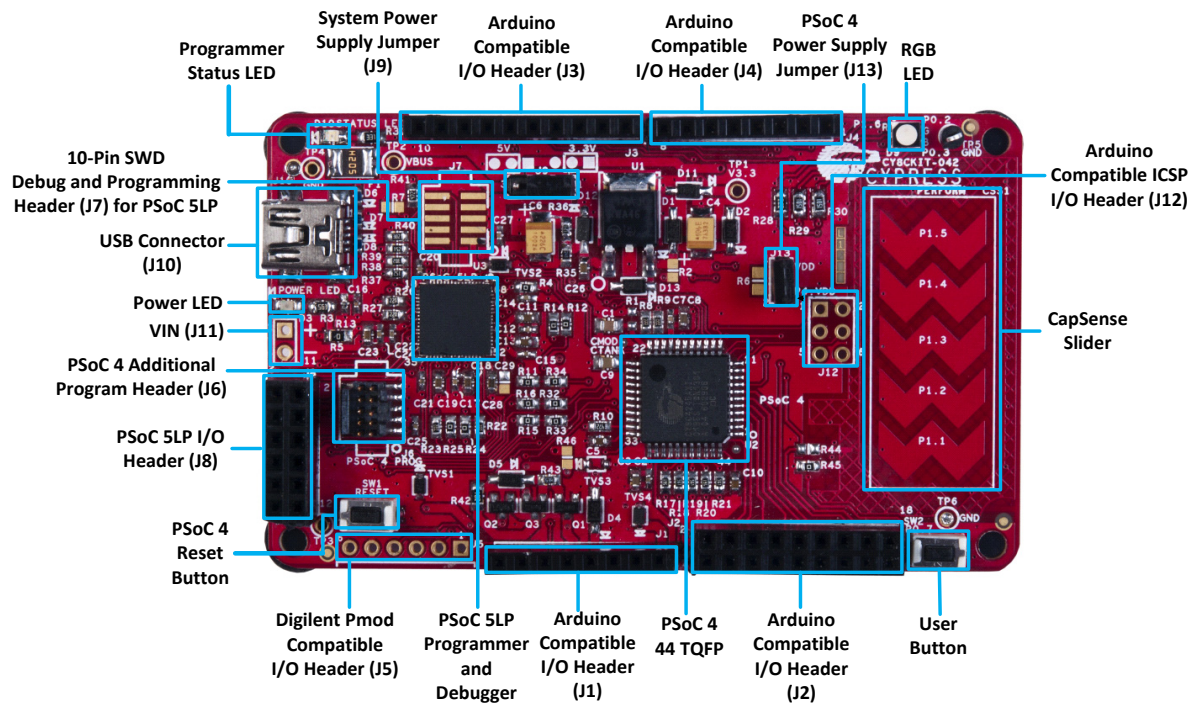

3.1 KitProg USB Connection

The PSoC 4 Pioneer Kit connects to the PC over a USB interface. The kit enumerates as a composite device and three separate devices appear under the Device Manager window in the Windows operating system.

Table 3-1. PSoC 4 Pioneer Kit in Device Manager After Enumeration

Port	Description
USB Composite Device	Composite device
USB Input Device	USB-I ² C bridge, KitProg command interface
KitProg	Programmer and debugger
KitProg USB-UART	USB-UART bridge, which appears as the COM# port

Figure 3-2. KitProg Driver Installation

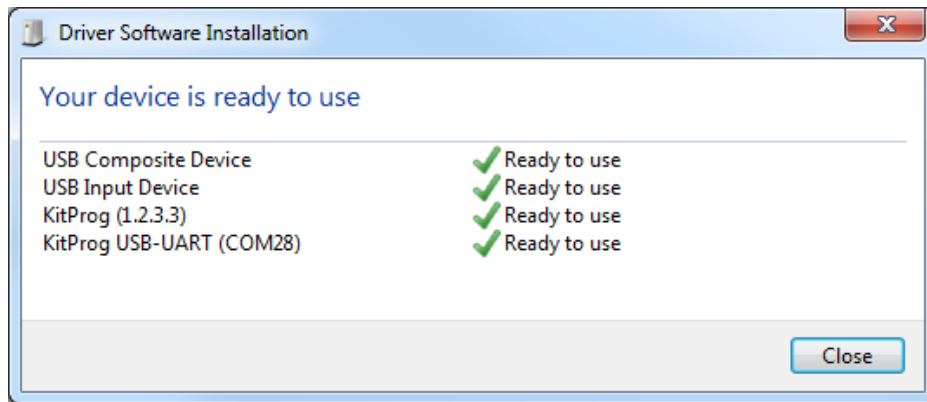

3.2 Programming and Debugging PSoC 4

The kit allows programming and debugging of the PSoC 4 device in two modes:

- Using the onboard PSoC 5LP programmer and debugger
- Using a CY8CKIT-002 MiniProg3 programmer and debugger

3.2.1 Using the Onboard PSoC 5LP Programmer and Debugger

The default programming interface for the kit is a USB-based, onboard programming interface. Before trying to program the device, PSoC Creator and PSoC Programmer must be installed. See [Install Kit Software on page 14](#) for information on installing the kit software.

1. To program the device, plug the USB cable into the programming USB connector J10, as shown in [Figure 3-3](#). The kit will enumerate as a composite device. See [KitProg USB Connection on page 18](#) for details.

Figure 3-3. Connect USB Cable to J10

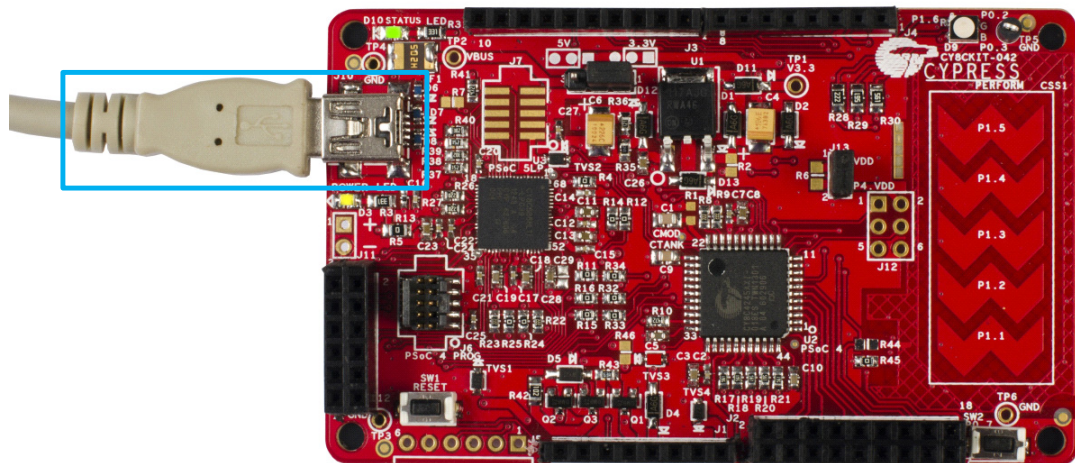

2. The onboard PSoC 5LP uses serial wire debug (SWD) to program the PSoC 4 device. See [Figure 3-4](#) for this implementation.

Figure 3-4. SWD Programming PSoC 4 Using PSoC 5LP

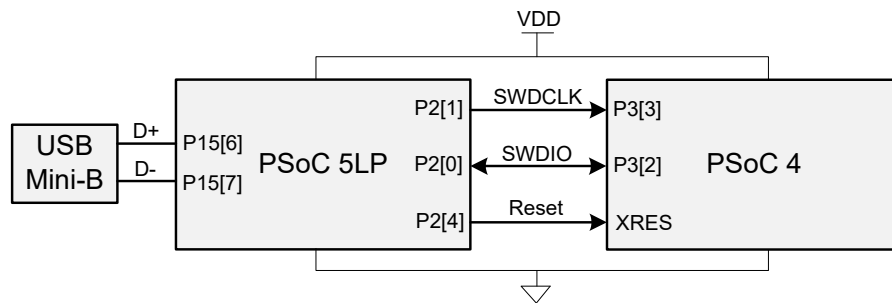

- The Pioneer Kit's onboard programmer will enumerate on the PC and in the software tools as **KitProg**. Load a code example in PSoC Creator (such as the examples described in the [Code Examples chapter on page 43](#)) and initiate the build by clicking **Build > Build Project** or **[Shift]+[F6]**.

Figure 3-5. Build Project in PSoC Creator

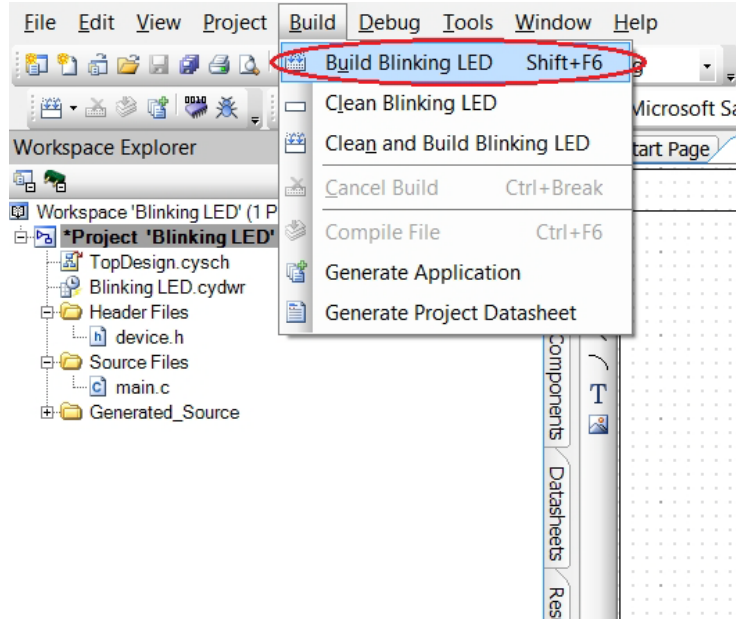

- After the project is built without errors and warnings, select **Debug > Program** or **[Ctrl]+[F5]** to program the device.

Figure 3-6. Program Device from PSoC Creator

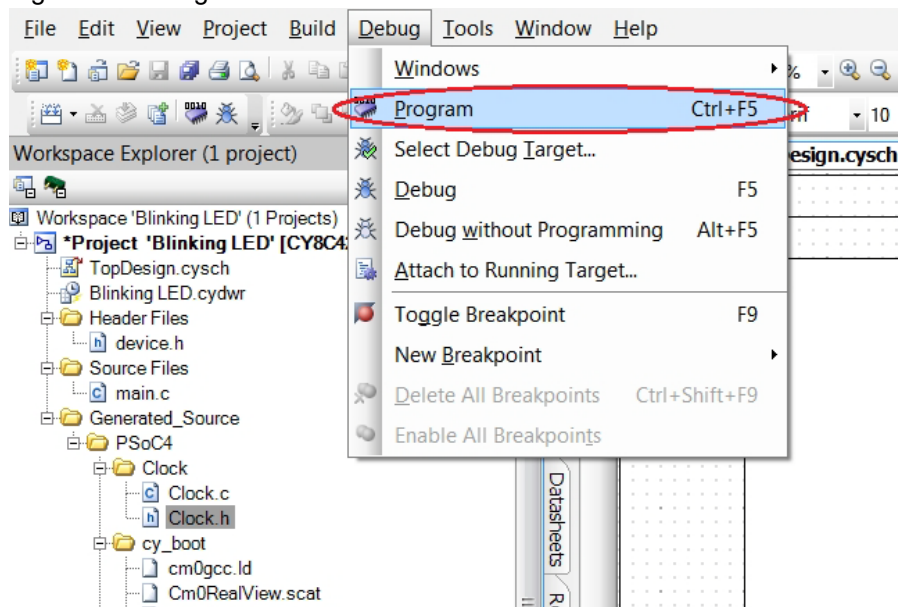

The onboard programmer supports only the RESET programming mode. When using the onboard programmer, the board can either be powered by the USB (VBUS) or by an external source such as an Arduino shield. If the board is already powered from another source, plugging in the USB programmer does not damage the board.

3.2.2 Using CY8CKIT-002 MiniProg3 Programmer and Debugger

The PSoC 4 on the Pioneer Kit can also be programmed using a MiniProg3 (CY8CKIT-002). To use MiniProg3 for programming, use the J6 connector on the board, as shown in [Figure 3-7](#).

The board can also be powered from the MiniProg3. To do this, select **Tool > Options**. In the Options window, expand **Program and Debug > Port Configuration**; click **MiniProg3** and select the settings shown in [Figure 3-8](#). Click **Debug > Program** to program and power the board.

Note: The CY8CKIT-002 MiniProg3 is not part of the PSoC 4 Pioneer Kit contents. It can be purchased from the [Cypress Online Store](#).

Figure 3-7. PSoC 4 Programming/Debugging Using MiniProg3

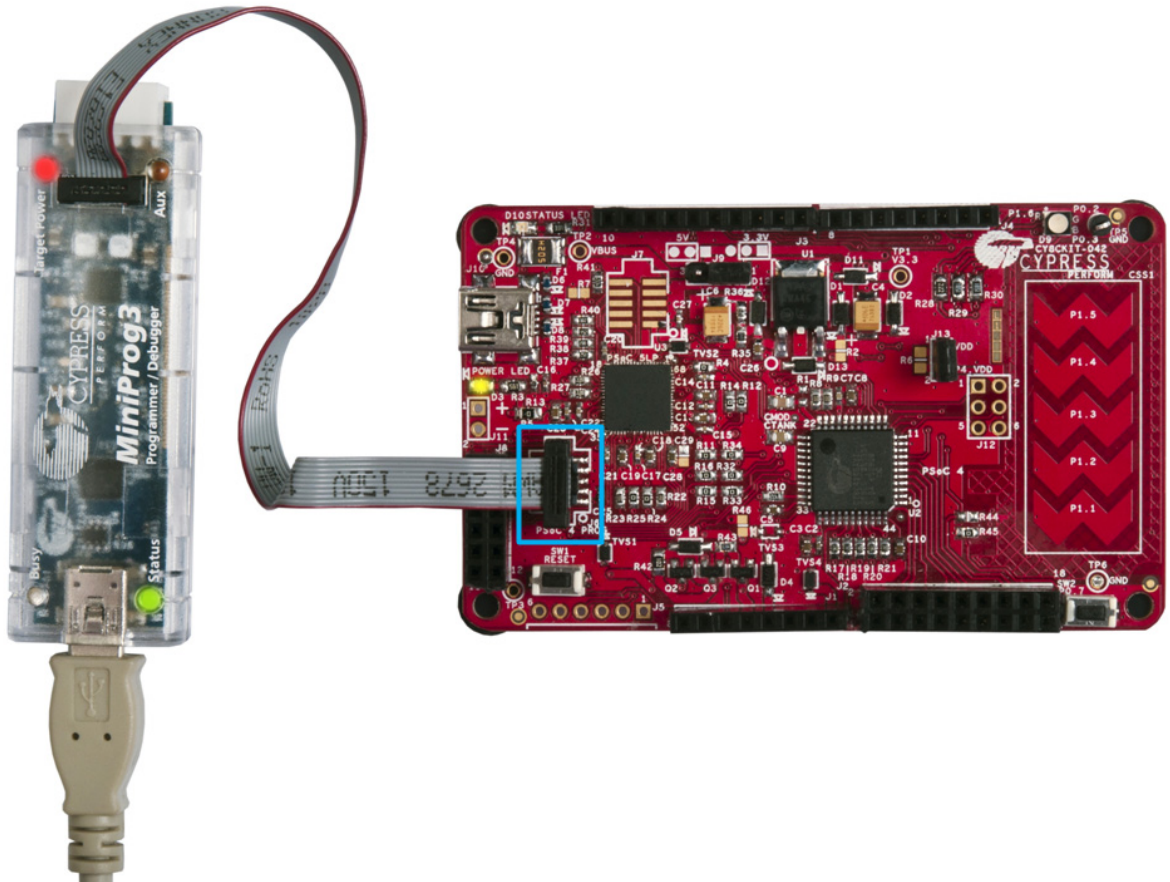
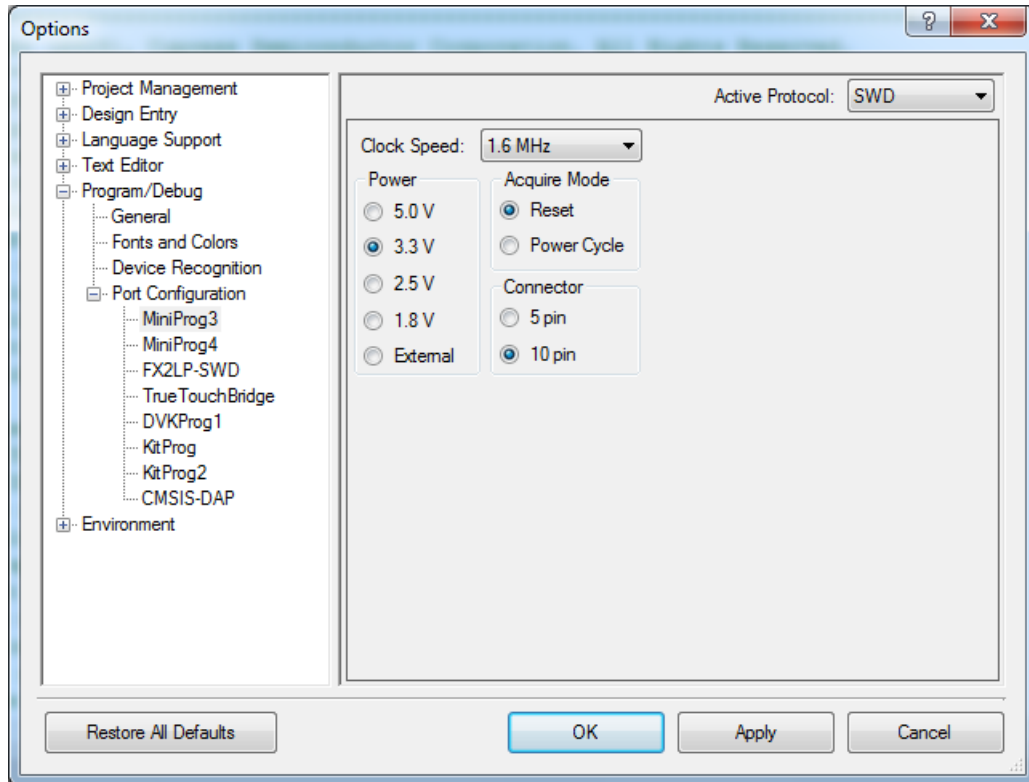

Figure 3-8. MiniProg3 Configuration



Note: See the [Programmer User Guide](#) for more information on programming using a MiniProg3.

3.3 USB-UART Bridge

The onboard PSoC 5LP can also act as a USB-UART bridge to transfer and receive data from the PSoC 4 device to the PC via the COM terminal software. When the USB mini-B cable is connected to J10 of the PSoC 4 Pioneer Kit, a device named **KitProg USB-UART** is available under Ports (COM & LPT) in the device manager. For more details about the USB-UART functionality, see [Using PSoC 5LP as a USB-UART Bridge on page 64](#).

To use the USB-UART functionality in the COM terminal software, select the corresponding COM port as the communication port for transferring data to and from the COM terminal software.

The UART lines from PSoC 5LP are brought to the P12[6] (J8.9) and P12[7] (J8.10) pins of header J8. This interface can be used to send or receive data from any PSoC 4 design that has a UART by connecting the pins on header J8 to the RX and TX pins assigned in PSoC 4. The UART can be used as an additional interface to debug designs. This bridge can also be used to interface with other external UART-based devices. [Figure 3-9](#) shows the connection between the RX and TX lines of the PSoC 5LP and PSoC 4. In this example, the PSoC 4 UART has been routed to the J4 header; the user must connect the wires between the PSoC 5LP RX and TX lines available on header J8.

Figure 3-9. Example RX and TX Line Connection of PSoC 5LP and PSoC 4

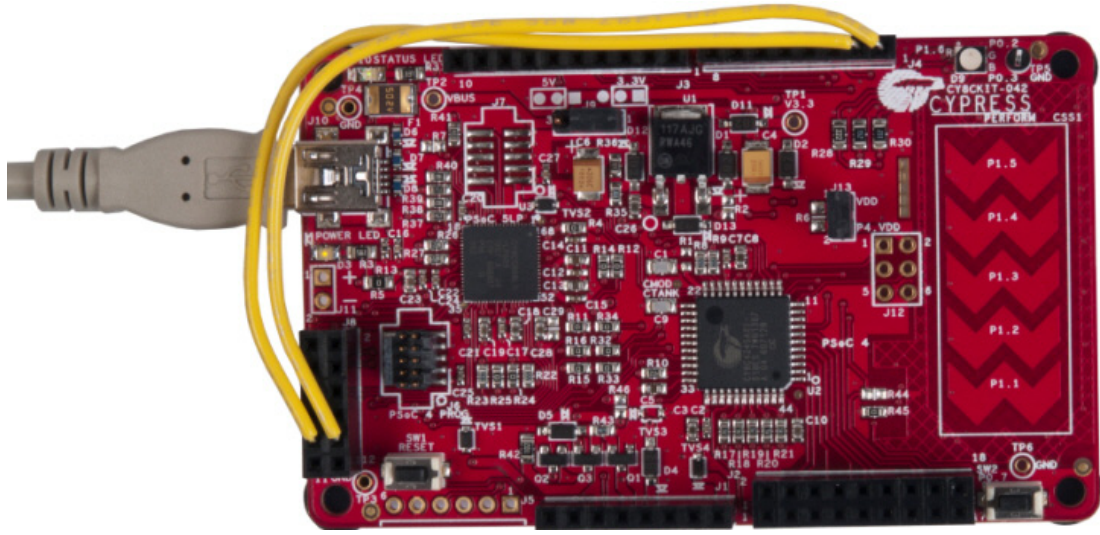

Table 3-2 lists the specifications supported by the USB-UART bridge.

Table 3-2. Specifications Supported by USB-UART Bridge

Parameter	Supported Values
Baud Rate	1200, 2400, 4800, 9600, 19200, 38400, 57600, and 115200
Data Bits	8
Parity	None
Stop Bits	1
Flow Control	None
File transfer protocols supported	Xmodem, 1K Xmodem, Ymodem, Kermit, and Zmodem (only speeds greater than 2400 baud).

3.4 USB-I2C Bridge

The PSoC 5LP also functions as a USB-I2C bridge. The PSoC 4 communicates with the PSoC 5LP using an I2C interface and the PSoC 5LP transfers the data over the USB to the USB-I2C software utility on the PC, called the Bridge Control Panel (BCP).

The BCP is available as part of the PSoC Programmer installation. This software can be used to send and receive USB-I2C data from the PSoC 5LP. When the USB mini-B cable is connected to header J10 on the PSoC 4 Pioneer Kit, the **KitProg/<serial_number>** is available under **Connected I2C/SPI/RX8 Ports** in the BCP.

Figure 3-10. Bridge Control Panel

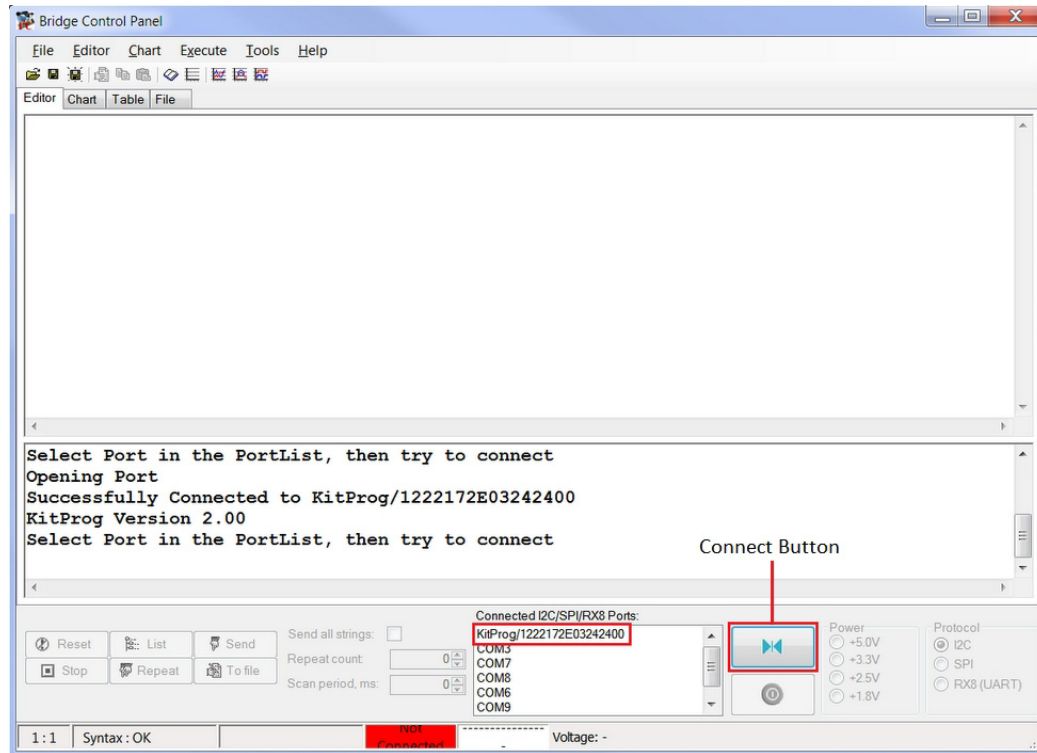

To use the USB_I2C functionality, select the **KitProg/<serial_number>** in the BCP. On successful connection, the **Connected** and **Powered** tabs turn green.

Figure 3-11. KitProg USB-I2C Connected in Bridge Control Panel

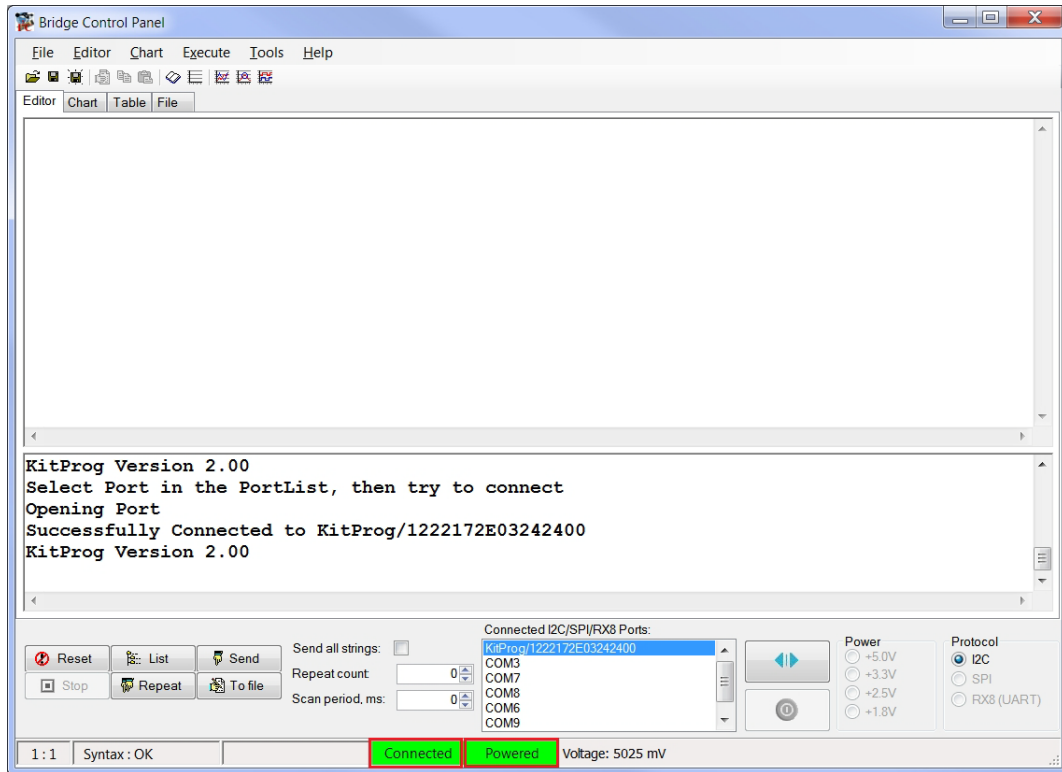

USB-I2C is implemented using the USB and I2C components of PSoC 5LP. The SCL (P12_0) and SDA (P12_1) lines from the PSoC 5LP are connected to SCL (P3_0) and SDA (P3_1) lines of the PSoC 4 I2C. The USB-I2C bridge currently supports I2C speed of 50 kHz, 100 kHz, 400 kHz, and 1 MHz.

Refer to [Using PSoC 5LP as USB-I2C Bridge on page 78](#) for building a project, which uses USB-I2C Bridge functionality.

3.5 Updating the Onboard Programmer Firmware

The firmware of the onboard programmer and debugger, PSoC 5LP, can be updated from PSoC Programmer. When a new firmware is available or when the KitProg firmware is corrupt (see [Error in Firmware/Status Indication in Status LED on page 115](#)), PSoC Programmer displays a warning indicating that new firmware is available.

Open PSoC Programmer from **Start > All Programs > Cypress > PSoC Programmer<version>**. When PSoC Programmer opens, a WARNING! window pops up saying that the programmer is currently out of date.

Figure 3-12. Firmware Update Warning

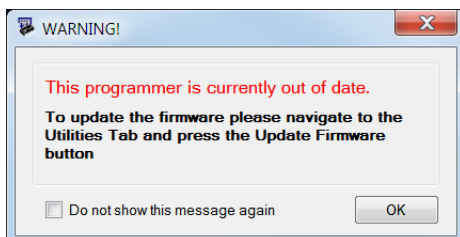

Click **OK** to close the window. On closing the warning window, the **Action and Results** window displays “Please navigate to the Utilities tab and click the Upgrade Firmware button”.

Figure 3-13. Upgrade Firmware Message in PSoC Programmer

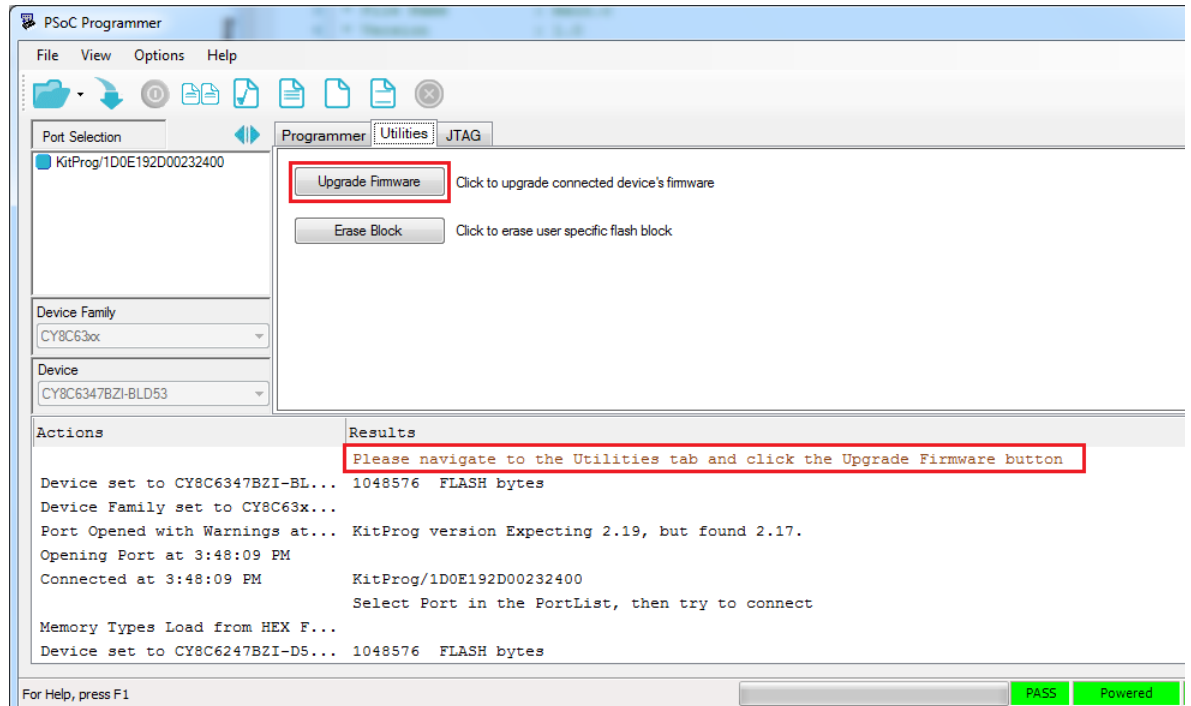

Click the **Utilities** tab and click the **Upgrade Firmware** button. On successful upgrade, the **Action and Results** window displays the firmware update message with the KitProg version.

Figure 3-14. Firmware Updated in PSoC Programmer

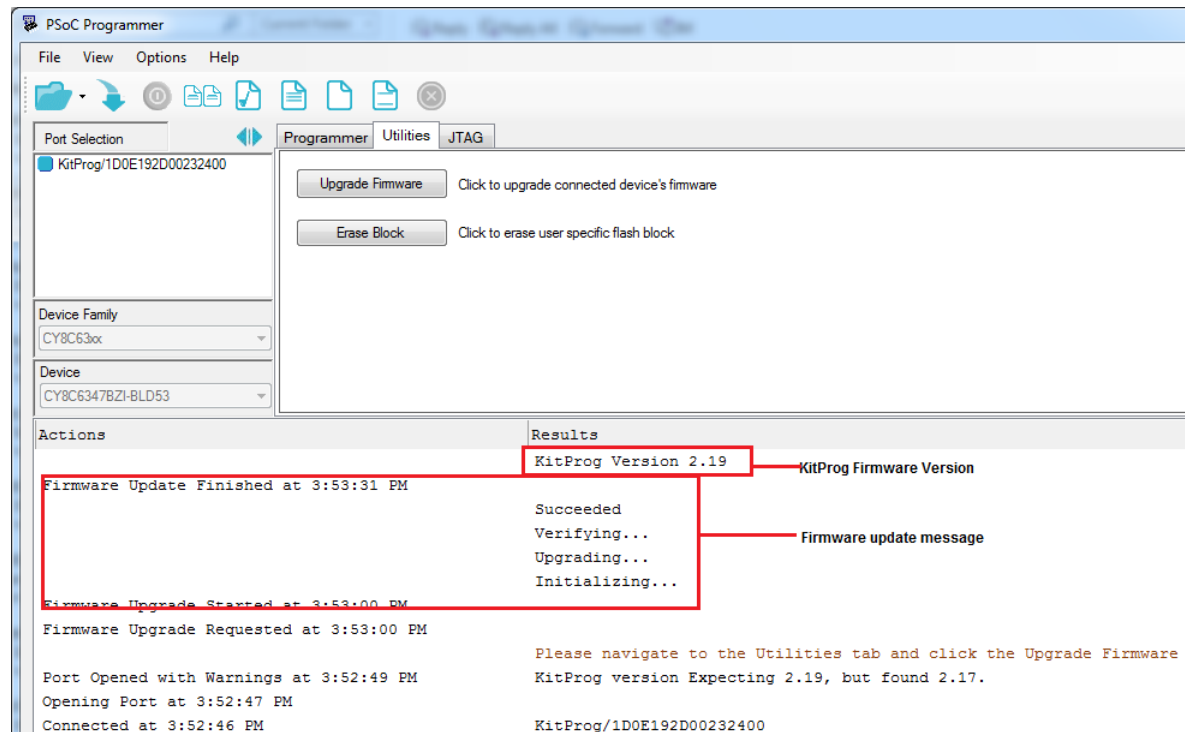

4. Hardware



4.1 Board Details

The PSoC 4 Pioneer Kit consists of the following blocks:

- PSoC 4
- PSoC 5LP
- Power supply system
- Programming interfaces (J6, J7 - unpopulated, J10)
- Arduino compatible headers (J1, J2, J3, J4, and J12 - unpopulated)
- Digilent Pmod compatible header (J5 - unpopulated)
- PSoC 5LP GPIO header (J8)
- CapSense slider
- Pioneer board LEDs
- Push buttons (Reset and User buttons)

Figure 4-1. PSoC 4 Pioneer Kit Details

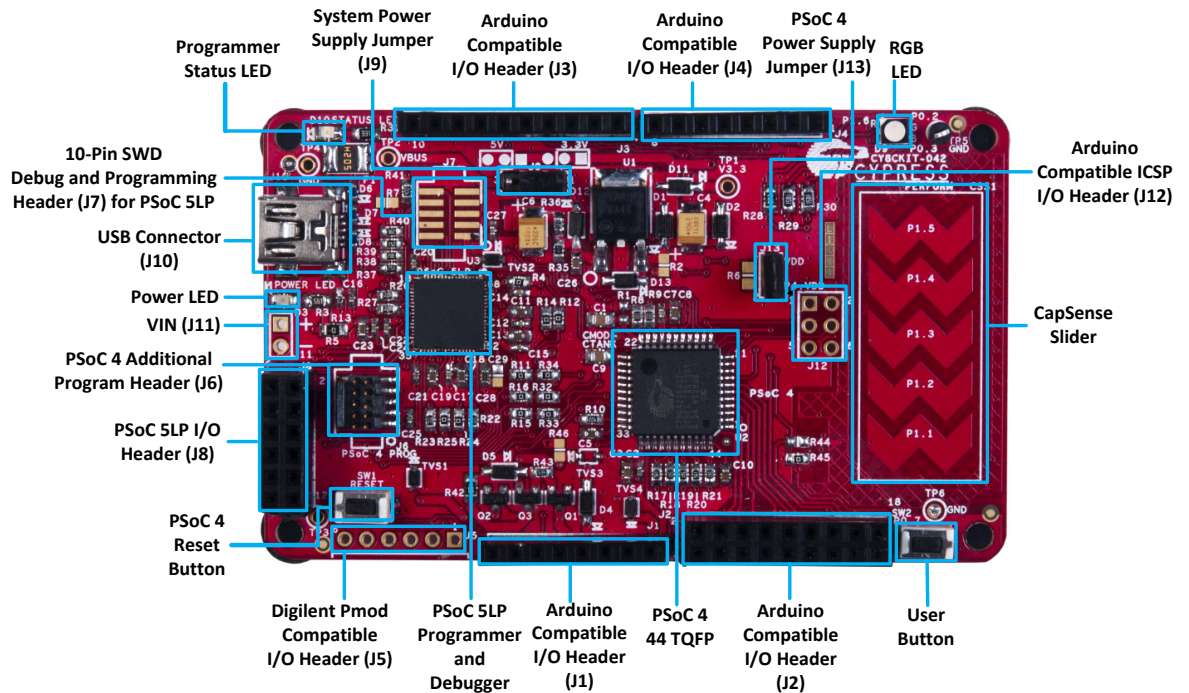
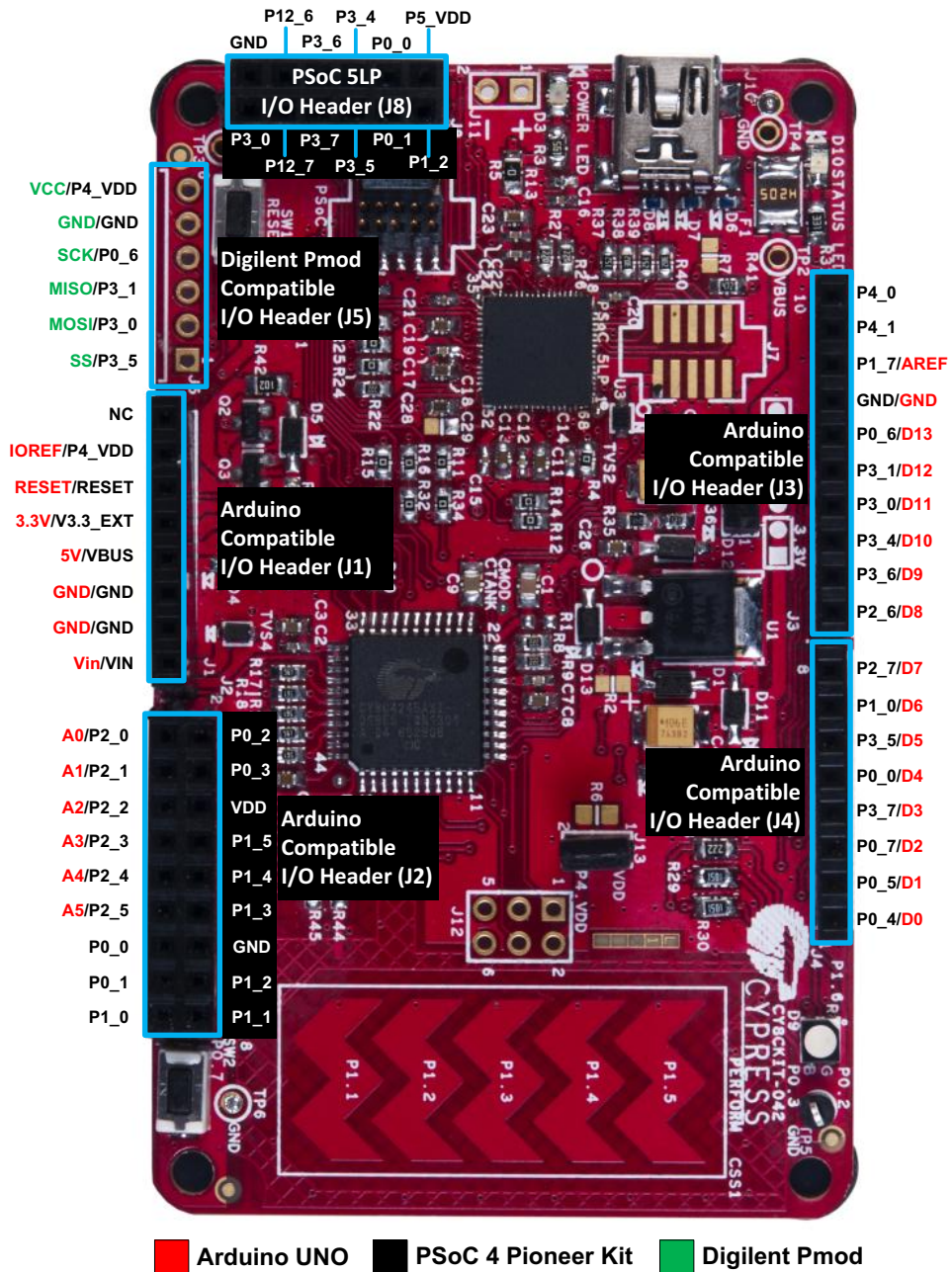

Figure 4-2. PSoC 4 Pioneer Kit Pin Mapping



4.2 Theory of Operation

This section provides the block-level description of the PSoC 4 Pioneer Kit.

Figure 4-3. Block Diagram

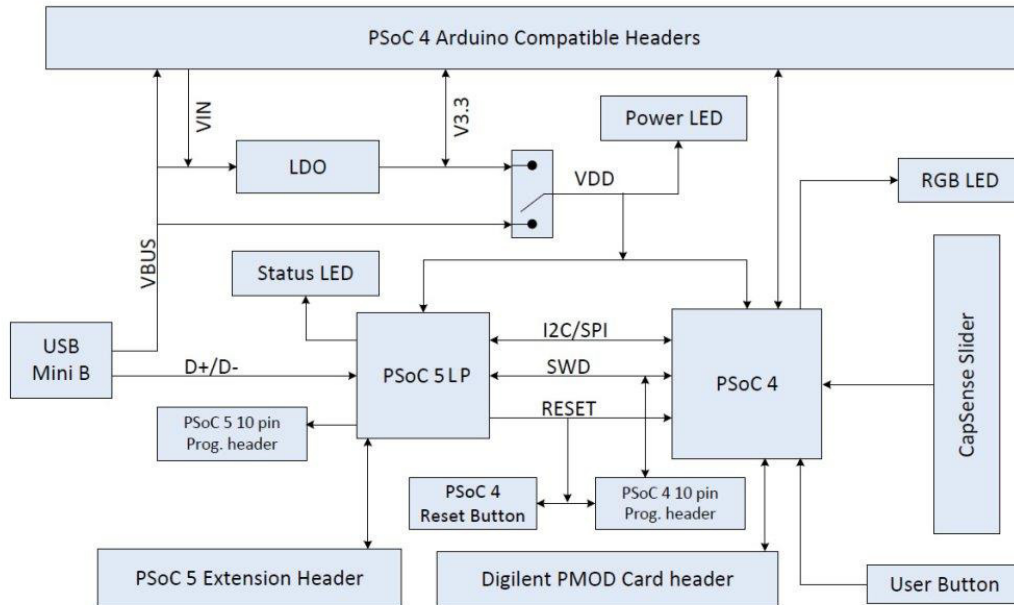

The PSoC 4 is a new generation of programmable system-on-chip devices from Cypress for embedded applications. It combines programmable analog, programmable digital logic, programmable I/O, and a high-performance Arm Cortex-M0 subsystem. With the PSoC 4, you can create the combination of peripherals required to meet the application specifications.

The PSoC 4 Pioneer Kit features an onboard PSoC 5LP, which communicates through the USB to program and debug the PSoC 4 using serial wire debug (SWD). The PSoC 5LP also functions as a USB-I2C bridge and USB-UART bridge.

The PSoC 4 Pioneer Kit has an RGB LED, a status LED, and a power LED. The RGB LED is connected to the PSoC 4 and the status LED is connected to the PSoC 5LP. For more information on the status LED, see section [Error in Firmware/Status Indication in Status LED on page 115](#). This kit also includes a reset button that connects to the PSoC 4 XRES, a user button, and a five-segment CapSense slider, which can be used to develop touch-based applications. The PSoC 4 pins are brought out onto headers J1 to J4 on the kit to support Arduino shields. The PSoC 5LP pins are brought out onto header J8 to enable using the onboard PSoC 5LP to develop custom applications.

The PSoC 4 Pioneer Kit can be powered from the USB Mini B, the Arduino compatible header, or an external power supply. The input voltage is regulated by a low drop-out (LDO) regulator to 3.3 V. You can select between VBUS (5 V) and 3.3 V by suitably plugging the jumper onto the voltage selection header VDD.

4.3 Functional Description

4.3.1 PSoC 4

This kit uses the PSoC 4200 family device. PSoC 4200 devices are a combination of a microcontroller with programmable logic, high-performance analog-to-digital conversion, two opamps with comparator mode, and commonly used fixed-function peripherals. For more information, refer to the [PSoC 4 webpage](#) and the [PSoC 4200 family datasheet](#).

Features

- 32-bit MCU subsystem
 - 48 MHz Arm Cortex-M0 CPU with single cycle multiply
 - Up to 32 KB of flash with read accelerator
 - Up to 4 KB of SRAM
- Programmable analog
 - Two opamps with reconfigurable high-drive external and high-bandwidth internal drive, comparator modes, and ADC input buffering capability
 - 12-bit 1-Msps SAR ADC with differential and single-ended modes; channel sequencer with signal averaging
 - Two current DACs (IDACs) for general-purpose or capacitive sensing applications on any pin
 - Two low-power comparators that operate in deep sleep
- Programmable digital
 - Four programmable logic blocks called universal digital blocks (UDBs), each with eight Macro-cells and data path
 - Cypress-provided peripheral component library, user-defined state machines, and Verilog input
- Low power 1.71 to 5.5 V operation
 - 20-nA Stop mode with GPIO pin wakeup
 - Hibernate and Deep-Sleep modes allow wakeup-time versus power trade-offs
- Capacitive sensing
 - Cypress Capacitive Sigma-Delta (CSD) provides best-in-class SNR (greater than 5:1) and water tolerance
 - Cypress-supplied software component makes capacitive sensing design easy
 - Automatic hardware tuning (SmartSense™)
- Segment LCD drive
 - LCD drive supported on all pins (common or segment)
 - Operates in Deep-Sleep mode with 4 bits per pin memory
- Serial communication
 - Two independent run-time reconfigurable serial communication blocks (SCBs) with re-configurable I2C, SPI, or UART functionality
- Timing and pulse-width modulation
 - Four 16-bit Timer/Counter Pulse-Width Modulator (TCPWM) blocks
 - Center-aligned, Edge, and Pseudo-random modes
 - Comparator-based triggering of Kill signals for motor drive and other high-reliability digital logic applications
- Up to 36 programmable GPIOs
 - 44-pin TQFP, 40-pin QFN, and 28-pin SSOP packages
 - Any GPIO pin can be CapSense, LCD, analog, or digital
 - Drive modes, strengths, and slew rates are programmable
- PSoC Creator design environment
 - Integrated development environment (IDE) provides schematic design entry and build (with analog and digital automatic routing)

- Applications Programming Interface (API) component for all fixed-function and programmable peripherals
- Industry-standard tool compatibility
 - After schematic entry, development can be done with Arm-based industry-standard development tools

For more information see the [CY8C42 family datasheet](#).

4.3.2 PSoC 5LP

An onboard PSoC 5LP is used to program and debug PSoC 4. The PSoC 5LP connects to the USB port of the PC through a USB Mini B connector and to the SWD interface of the PSoC 4 device.

PSoC 5LP is a true system-level solution providing MCU, memory, analog, and digital peripheral functions in a single chip. The CY8C58LPxx family offers a modern method of signal acquisition, signal processing, and control with high accuracy, high bandwidth, and high flexibility. Analog capability spans the range from thermocouples (near DC voltages) to ultrasonic signals. For more information, refer to the [PSoC 5LP webpage](#).

Features

- 32-bit Arm Cortex-M3 CPU core
 - DC to 67-MHz operation
 - Flash program memory, up to 256 KB, 100,000 write cycles, 20-year retention, and multiple security features
 - Up to 32-KB flash error correcting code (ECC) or configuration storage
 - Up to 64 KB SRAM
 - 2-KB electrically erasable programmable read-only memory (EEPROM) memory, 1 M cycles, and 20 years retention
 - 24-channel direct memory access (DMA) with multilayer AHB bus access
 - a. Programmable chained descriptors and priorities
 - b. High bandwidth 32-bit transfer support
- Low voltage, ultra low power
 - Wide operating voltage range: 0.5 V to 5.5 V
 - High-efficiency boost regulator from 0.5 V input to 1.8 V to 5.0 V output
 - 3.1 mA at 6 MHz
 - Low power modes including:
 - a. 2- μ A sleep mode with real time clock (RTC) and low-voltage detect (LVD) interrupt
 - b. 300-nA hibernate mode with RAM retention
- Versatile I/O system
 - 28 to 72 I/Os (62 GPIOs, 8 SIOs, 2 USBIOs)
 - Any GPIO to any digital or analog peripheral routability
 - LCD direct drive from any GPIO, up to 46 \times 16 segments
 - CapSense support from any GPIO[3]
 - 1.2 V to 5.5 V I/O interface voltages, up to 4 domains
 - Maskable, independent IRQ on any pin or port
 - Schmitt-trigger transistor-transistor logic (TTL) inputs
 - All GPIOs configurable as open drain high/low, pull-up/pull-down, High-Z, or strong output
 - Configurable GPIO pin state at power-on reset (POR)
 - 25 mA sink on SIO
- Digital peripherals
 - 20 to 24 programmable logic device (PLD) based universal digital blocks (UDBs)
 - Full CAN 2.0b 16 RX, 8 TX buffers
 - Full-Speed (FS) USB 2.0 12 Mbps using internal oscillator

- Four 16-bit configurable timers, counters, and PWM blocks
- 67-MHz, 24-bit fixed point digital filter block (DFB) to implement finite impulse response (FIR) and infinite impulse response (IIR) filters
- Library of standard peripherals
 - a. 8-, 16-, 24-, and 32-bit timers, counters, and PWMs
 - b. Serial peripheral interface (SPI), universal asynchronous transmitter receiver (UART), and I2C
 - c. Many others available in catalog
- Library of advanced peripherals
 - a. Cyclic redundancy check (CRC)
 - b. Pseudo random sequence (PRS) generator
 - c. Local interconnect network (LIN) bus 2.0
 - d. Quadrature decoder
- Analog peripherals ($1.71\text{ V} \leq V_{DDA} \leq 5.5\text{ V}$)
- $1.024\text{ V} \pm 0.1\%$ internal voltage reference across $-40\text{ }^{\circ}\text{C}$ to $+85\text{ }^{\circ}\text{C}$
- Configurable delta-sigma ADC with 8- to 20-bit resolution
- Sample rates up to 192 ksps
- Programmable gain stage: $\times 0.25$ to $\times 16$
- 12-bit mode, 192 ksps, 66-dB signal to noise and distortion ratio (SINAD), ± 1 -bit INL/DNL
- 16-bit mode, 48 ksps, 84-dB SINAD, ± 2 -bit INL, ± 1 -bit DNL
- Up to two SAR ADCs, each 12-bit at 1 Msps
- Four 8-bit 8 Msps current IDACs or 1-Msps voltage VDACS
- Four comparators with 95-ns response time
- Four uncommitted opamps with 25-mA drive capability
- Four configurable multifunction analog blocks. Example configurations are programmable gain amplifier (PGA), transimpedance amplifier (TIA), mixer, and sample and hold
- CapSense support
- Programming, debug, and trace
 - JTAG (4 wire), SWD (2 wire), single wire viewer (SWV), and TRACEPORT interfaces
 - Cortex-M3 flash patch and breakpoint (FPB) block
 - Cortex-M3 Embedded Trace Macrocell™ (ETM™) generates an instruction trace stream
 - Cortex-M3 data watchpoint and trace (DWT) generates data trace information
 - Cortex-M3 Instrumentation Trace Macrocell (ITM) can be used for printf-style debugging
 - DWT, ETM, and ITM blocks communicate with off-chip debug and trace systems via the SWV or TRACEPORT
 - Bootloader programming supportable through I2C, SPI, UART, USB, and other interfaces
- Precision, programmable clocking
 - 3- to 62-MHz internal oscillator over full temperature and voltage range
 - 4- to 25-MHz crystal oscillator for crystal PPM accuracy
 - Internal PLL clock generation up to 67 MHz
 - 32.768-kHz watch crystal oscillator
 - Low-power internal oscillator at 1, 33, and 100 kHz

For more, see the [CY8C58LPxx family datasheet](#).

4.3.3 Power Supply System

The power supply system on this board is versatile, allowing the input supply to come from the following sources:

- 5-V power from onboard USB programming header J10
- 5-V to 12-V power from Arduino shield using J1.1 header
- VTARG - power from the onboard SWD programming using J6 or J7
- VIN - J11

The PSoC 4 and PSoC 5LP are powered with either a 3.3 V or 5 V source. The selection between 3.3 V and 5 V is made through the J9 jumper. The board can supply 3.3 V and 5 V to the I/O headers and receive 3.3 V from the I/O headers. The board can also be powered with an external power supply through the VIN (J11) header; the allowed voltage range for the VIN is 5 V to 12 V. The LDO regulator regulates the VIN down to 3.3 V. Figure 4-4 shows the power supply block diagram and protection circuitry.

Note: The 5-V domain is directly powered by the USB (VBUS). For this reason, this domain is unregulated.

Figure 4-4. Power Supply Block Diagram with Protection Circuits

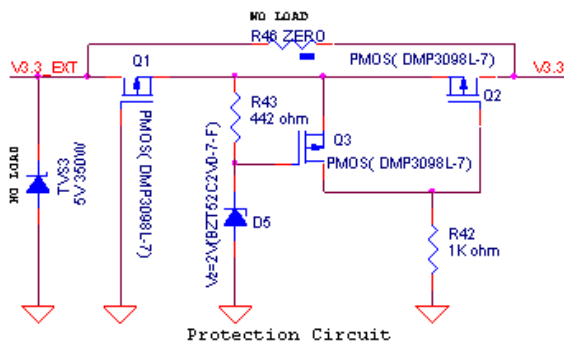
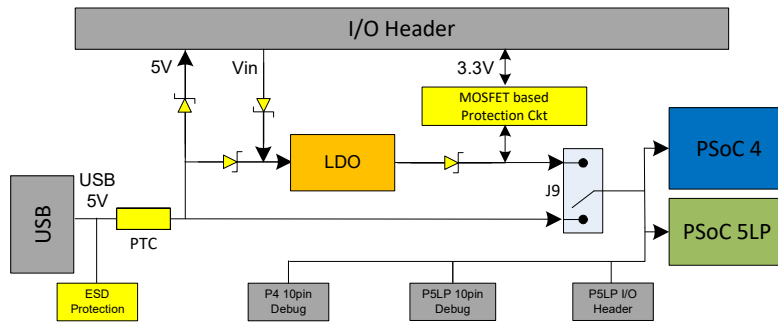

4.3.3.1 Protection Circuit

The power supply rail has reverse-voltage, over-voltage, short circuits, and excess current protection features, as seen in [Figure 4-4](#).

- The Schottky diode (D4) ensures power cannot be supplied to the 5-V domain of the board from the I/O header.
- The series protection diode (D2) ensures VIN (power supply from the I/O header) does not back power the USB.
- The Schottky diode (D11) ensures 3.3 V from I/O header does not back power the LDO.
- The series protection diode (D13) ensures that the reverse-voltage cannot be supplied from the VIN to the regulator input.
- A PTC resettable fuse is connected to protect the computer's USB ports from shorts and over-current.
- The MOSFET-based protection circuit provides over-voltage and reverse-voltage protection to the 3.3-V rail. The PMOS Q1 protects the board components from a reverse-voltage condition. The PMOS Q2 protects the PSoC from an over-voltage condition. The PMOS Q2 will turn off when a voltage greater than 4.2 V is applied, protecting the PSoC 4.
- The output voltage of the LDO is adjusted such that it takes into account the voltage drop across the Schottky diode and provides 3.3 V.

4.3.3.2 Procedure to Measure PSoC 4 Current Consumption

The following three methods are supported for measuring current consumption of the PSoC 4 device.

- When the board is powered through the USB port (J10), remove jumper J13 and connect an ammeter, as shown in [Figure 4-5](#).

Figure 4-5. PSoC 4 Current Measurement when Powered from USB Port

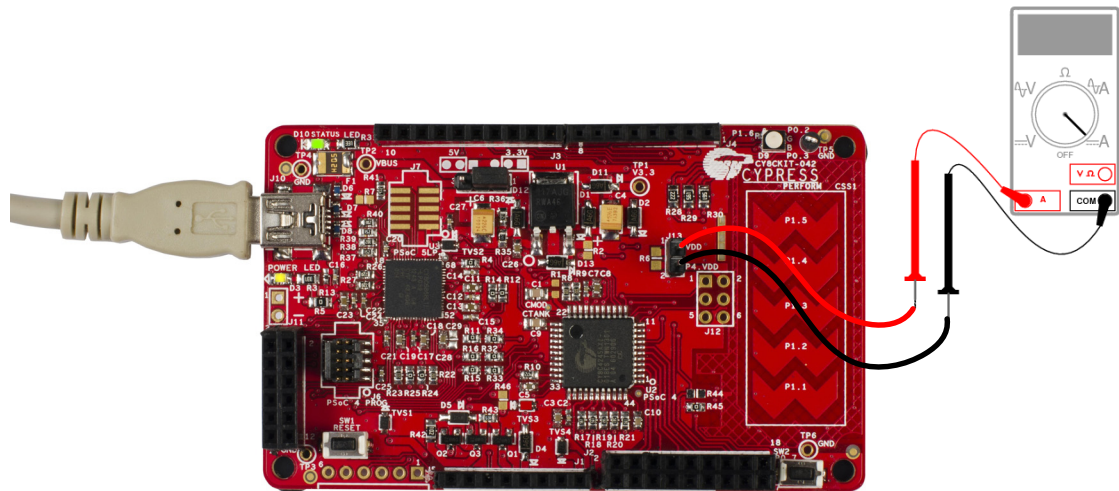

- When using a separate power supply for the PSoC 4 with USB powering (regulator output on the USB supply must be within 0.5 V of the separate power supply).
 - Remove jumper J13. Connect the positive terminal of voltage supply to the positive terminal of the ammeter and the negative terminal of the ammeter to the lower pin of J13. [Figure 4-6](#) shows the required connections.

Figure 4-6. PSoC 4 Current Measurement when Powered Separately

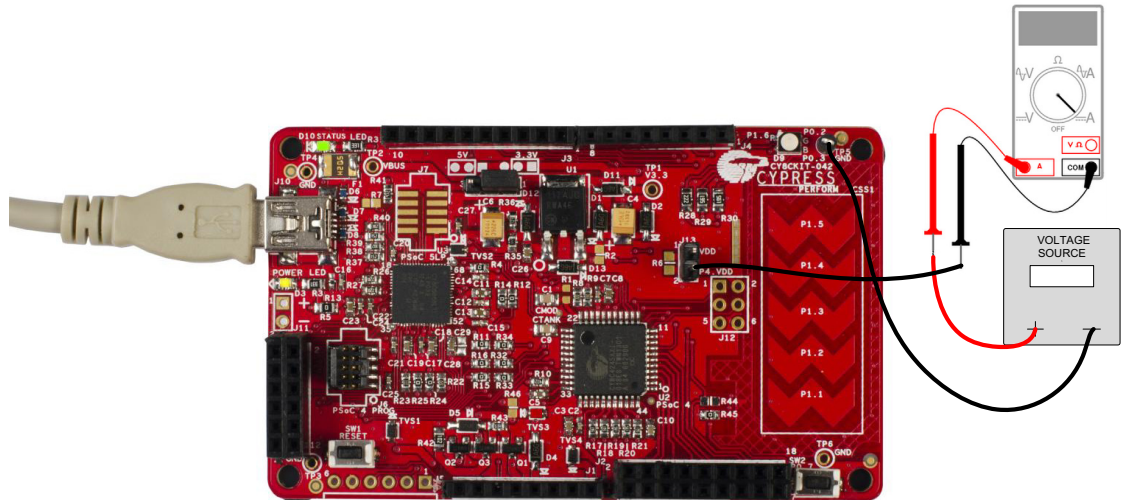

- When the PSoC 4 is powered separately and the PSoC 5LP is not powered, make these changes to avoid leakage while measuring current:
 - Remove the zero-ohm resistors R24 and R25. Removing these resistors will affect the USB-I2C functionality.
 - Remove R32, R33, and R34, which are meant for programming the PSoC 4. Removing these resistors disables the PSoC 5LP capability for programming.
 - Connect an ammeter between pins 1 and 2 of header J13 to measure current.

Figure 4-7. Zero-ohm Resistor Position

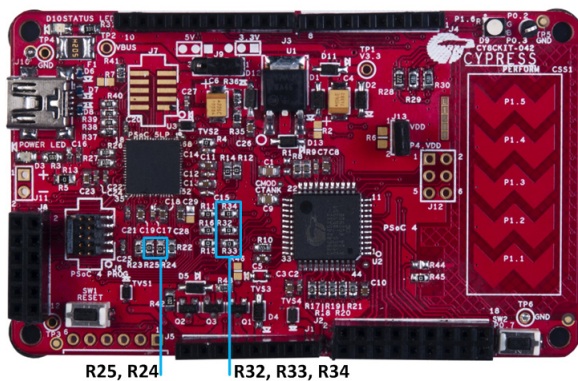

4.3.4 Programming Interface

The kit allows programming and debugging of the PSoC 4 in two modes:

- [Using the Onboard PSoC 5LP Programmer and Debugger on page 19](#)
- [Using CY8CKIT-002 MiniProg3 Programmer and Debugger on page 21](#)

4.3.5 Arduino Compatible Headers (J1, J2, J3, J4, and J12 - unpopulated)

This kit has five Arduino compatible headers; J1, J2, J3, J4 and J12. You can develop applications based on the Arduino shield's hardware.

Figure 4-8. Arduino Header

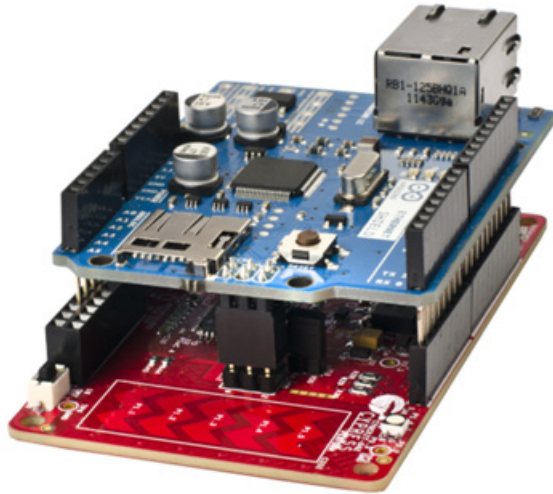

The J1 header contains I/O pins for reset, internal reference voltage (IOREF), and power supply line. The J2 header is an analog port. It contains I/O pins for SAR ADC, comparator, and opamp. The J3 header is primarily a digital port. It contains I/O pins for PWM, I2C, SPI, and analog reference. The J4 header is also a digital port. It contains I/O pins for UART and PWM. The J12 header is an Arduino ICSP compatible header for the SPI interface. This header is not populated. Refer to the “No Load Components” section of [Bill of Materials \(BOM\) on page 116](#) for the header part number.

Note: The PSoC 4 pin P0[0] is connected to both pin 13 of the J2 header and pin 5 of the J4 header. Similarly, the PSoC 4 pin P1[0] is connected to both pin 17 of the J2 header and pin 7 of the J4 header. Therefore, when using P0[0] or P1[0] from either the J2 or J4 header, there should not be any external signal connected to the other header.

Figure 4-9. Arduino Compatible Headers

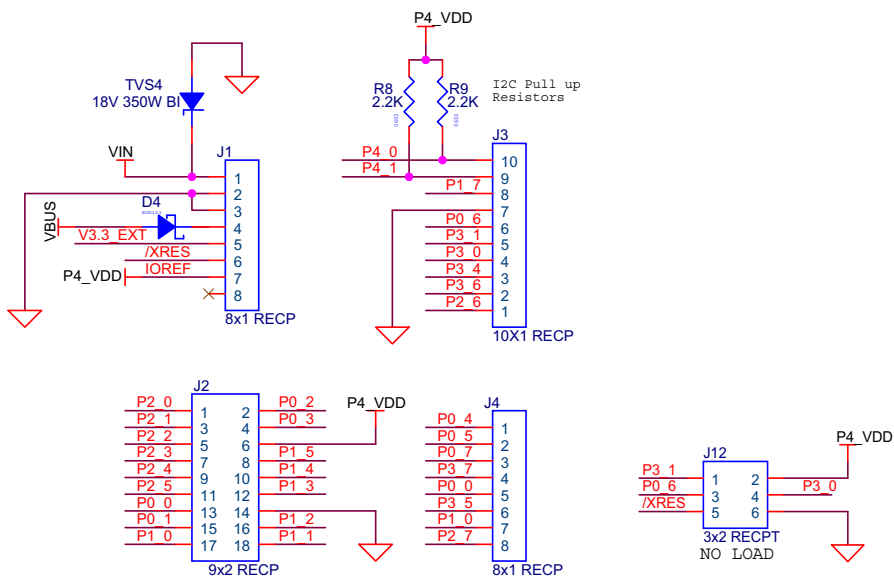
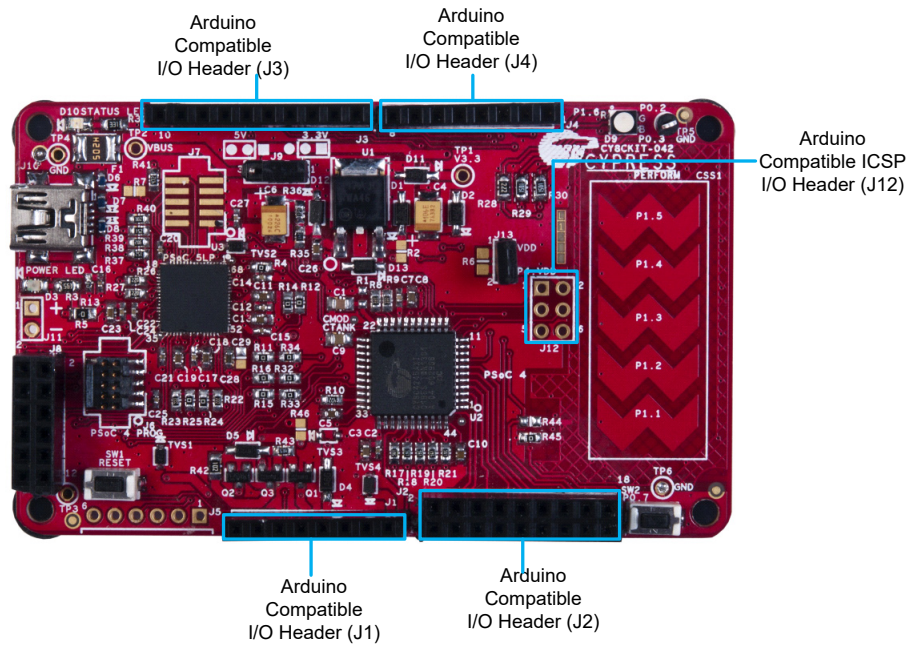

(J1-J4) Arduino Compatible Headers

4.3.5.1 Additional Functionality of Header J2

The J2 header is a 9×2 header that supports Arduino shields. The port 0, port 1, and port 2 pins of PSoC 4 are brought to this header. The port 1 pins additionally connect to the onboard CapSense slider through 560-Ω resistors. When the CapSense feature is not used, remove these resistors to ensure a better performance with these pins.

4.3.5.2 *Functionality of Unpopulated Header J12*

The J12 header is a 2×3 header that supports Arduino shields. This header is used on a small subset of shields and is unpopulated on the PSoC 4 Pioneer Kit. Note that the J12 header only functions in 5.0 V mode. To ensure proper shield functionality, ensure the power jumper is connected in 5.0 V mode.

4.3.6 Digilent Pmod Compatible Header (J5 - unpopulated)

This port supports Digilent Pmod peripheral modules. Pmods are small I/O interfaces, which connect with the embedded control boards through either 6- or 12-pin connectors. The PSoC 4 Pioneer Kit supports the 6-pin Pmod type 2 (SPI) interface. For Digilent Pmod cards, go to www.digilentinc.com.

This header is not populated on the PSoC 4 Pioneer Kit. You must populate this header before connecting the Pmod daughter cards. Refer to the “No Load Components” section of [Bill of Materials \(BOM\) on page 116](#) for the header part number.

Figure 4-10. Pmod Connection

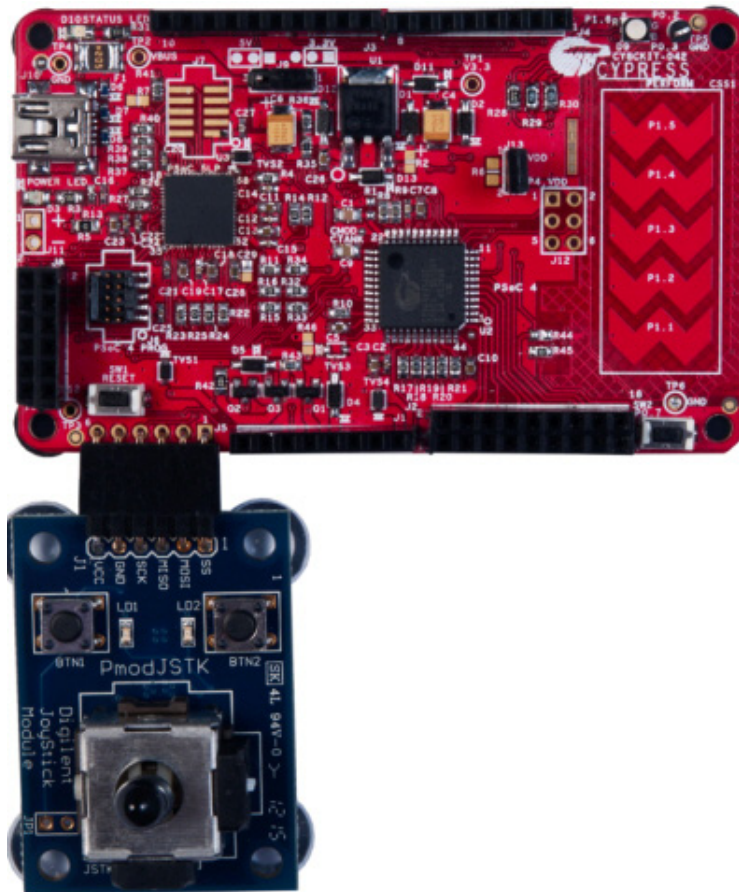
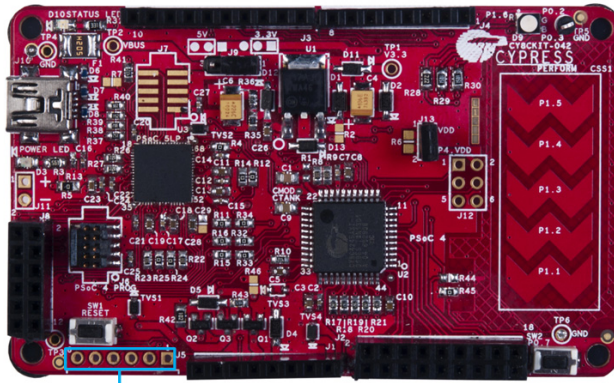
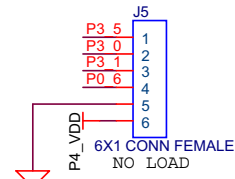

Figure 4-11. Digilent Pmod Interface



Digilent® Pmod™ Compatible I/O Header (J5)



J5 Digilent Pmod Cards Compatible Headers

See [Pin Assignment Table](#) on page 111 for details on the pin descriptions for the J5 header.

4.3.7 PSoC 5LP GPIO Header (J8)

A limited set of PSoC 5LP pins are brought to this header. Refer to [Developing Applications for PSoC 5LP](#) on page 87 for details on how to develop custom applications. See [Pin Assignment Table](#) on page 111 for pin details.

Figure 4-12. PSoC 5LP GPIO Header (J8)

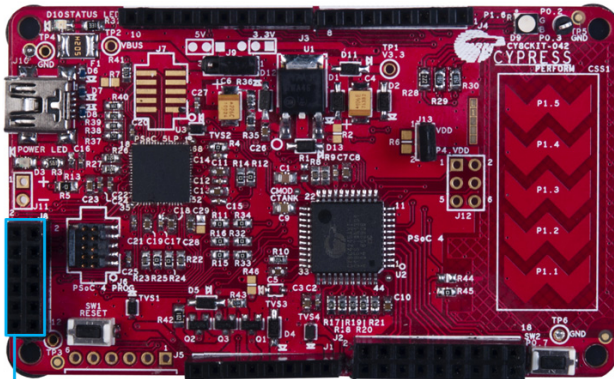

PSoC 5LP I/O Header (J8)

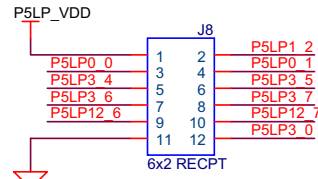

PSoC 5LP GPIO Extension Header

4.3.8 CapSense Slider

The kit has a five-segment linear capacitive touch slider on the board, which is connected to pins P1[1] to P1[5] of the PSoC 4 device.

The modulation capacitor (Cmod) is connected to pin P4[2] and an optional bleeder resistor (R1) can be connected across the Cmod. This board supports CapSense designs that enable waterproofing.

The waterproofing design uses a concept called shield, which is a conductor placed around the sensors. This shield must be connected to a designated shield pin on the device to function. The shield must be connected to the ground when not used. On the PSoC 4 Pioneer Kit, the connection of the shield to the pin or to the ground is made by resistors R44 and R45, respectively. By default, R45 is mounted on the board, which connects the shield to the ground. Populate R44 when evaluating waterproofing designs, which will connect the shield to the designated pin, P0[1]. This shield is different from the Arduino shields, which are boards that connect over the Arduino header. Refer to the [CapSense Design Guide](#) for further details related to CapSense.

Figure 4-13. CapSense Slider

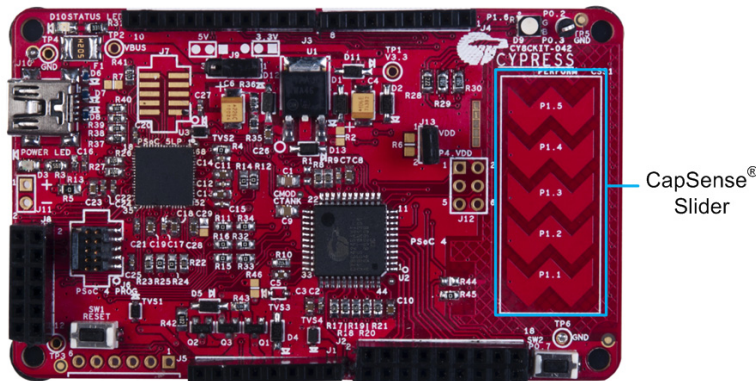
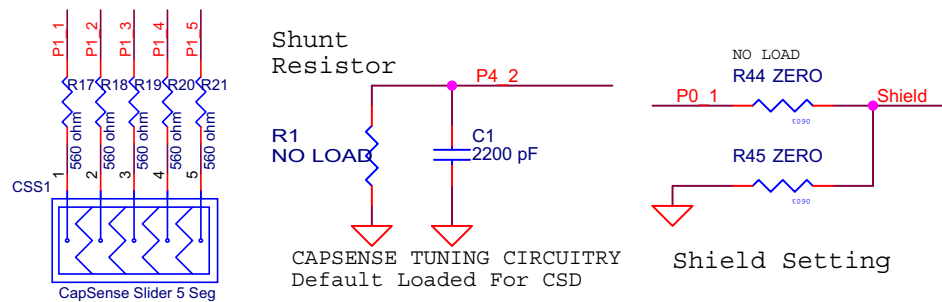

Figure 4-14. CapSense Slider Connection



4.3.9 Pioneer Board LEDs

The PSoC 4 Pioneer board has three LEDs. A green LED (D10) indicates the status of the programmer. See [Error in Firmware/Status Indication in Status LED on page 115](#) for a detailed list of LED indications. An amber LED (D3) indicates status of power supplied to the board. The kit also has a general-purpose tricolor LED (D9) for user applications that connect to specific PSoC 4 pins.

[Figure 4-15](#) shows the indication of all these LEDs on the board. [Figure 4-16](#) and [Figure 4-17](#) detail the LED schematic.

Figure 4-15. PSoC 4 Pioneer Board LEDs

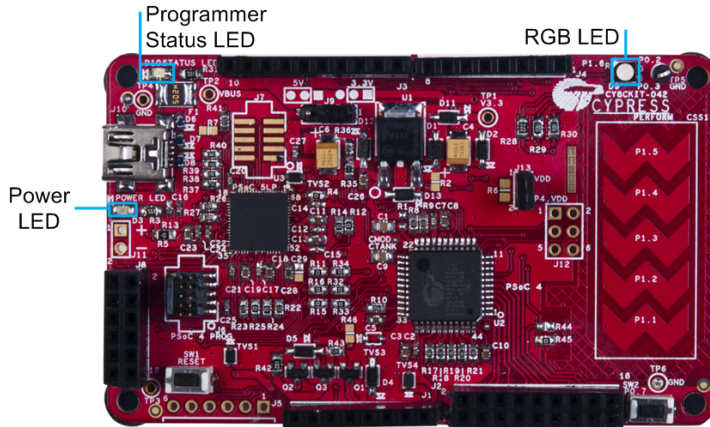
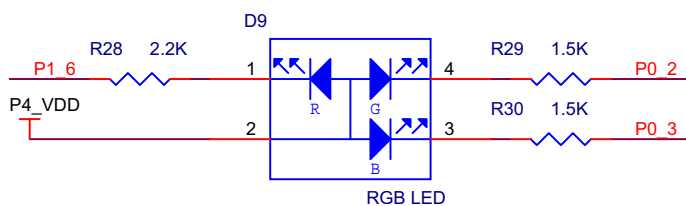

Figure 4-16. Status LED and Power LED



Figure 4-17. RGB LED



4.3.10 Push Buttons

The kit contains a Reset push button and a User push button, as shown in [Figure 4-18](#).

The Reset button is connected to the XRES pin of PSoC 4 and is used to reset the onboard PSoC 4 device. The User button is connected to P0[7] of PSoC 4 device. Both the push buttons connect to ground on activation (active low).

Figure 4-18. Push Buttons

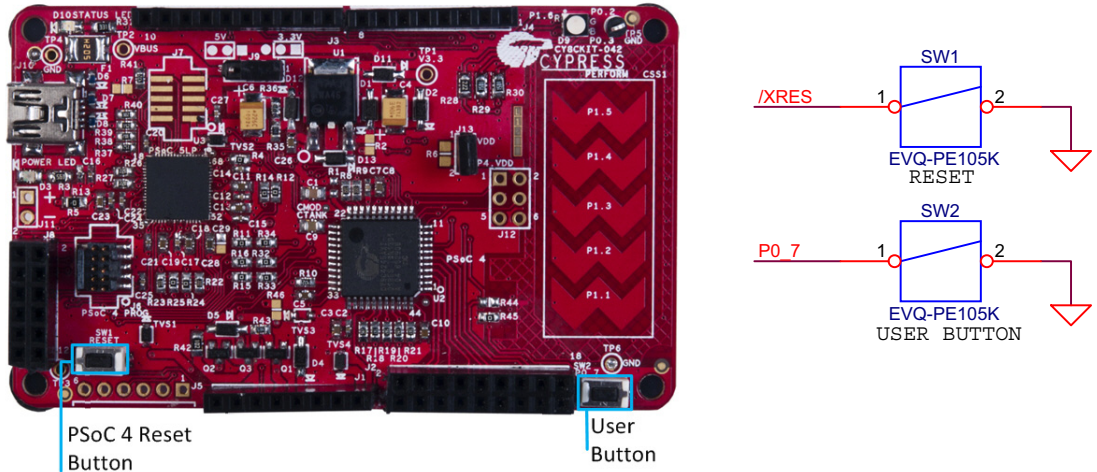

Note: The PSoC 4 Reset pin (XRES) has an internal pull-up resistor. However, an external pull-up resistor R10 is connected to the PSoC 4 Reset pin on the kit, which is optional and required only in a noisy system.

5. Code Examples



The code examples described in this chapter introduce the functionality of the PSoC 4 device and the onboard components. To access the examples, download the CD ISO image or setup files from the kit [webpage](#). After installation, the code examples will be available from **Start > Kits** on the PSoC Creator Start Page. For a list of all code examples available with PSoC Creator visit [PSoC 3/ PSoC 4/PSoC 5LP Code Examples webpage](#).

5.1 Using the Kit Code Examples

Follow these steps to open and program code examples:

1. Launch PSoC Creator from **Start > All Programs > Cypress > PSoC Creator<version> > PSoC Creator <version>**.
2. On the Start page, click **CY8CKIT-042** under **Start > Kits**. A list of code examples appears, as shown in [Figure 5-1](#).

Figure 5-1. Open Code Example from PSoC Creator

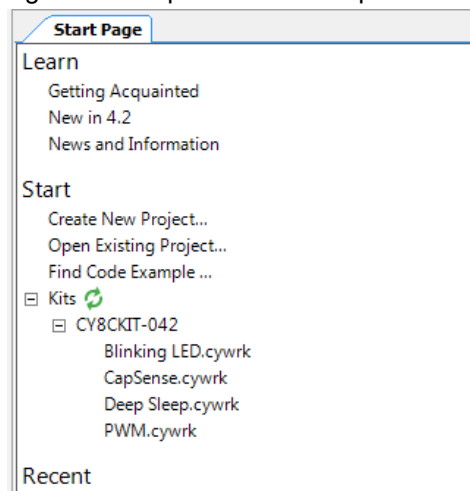

3. Build the code example by choosing **Build > Build <Project name>**. After the build process is successful, a `.hex` file is generated.

Figure 5-2. Build Code Example from PSoC Creator

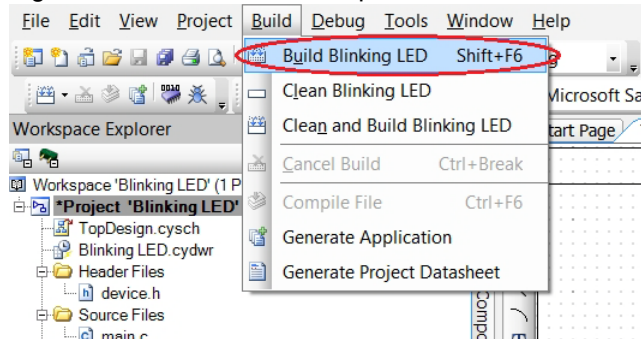

4. To program, connect the PSoC 4 Pioneer Kit to the computer using the USB cable connected to port J10, as described in section [Programming and Debugging PSoC 4 on page 19](#). The board is detected as **KitProg**.
5. Choose **Debug > Program** in PSoC Creator.

Figure 5-3. Program Device from PSoC Creator

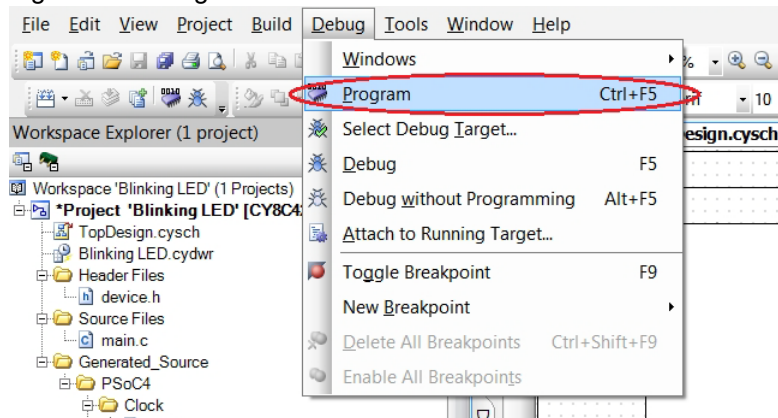

6. If the device is yet to be acquired, the Select Debug Target window will appear. Select **KitProg/ <serial_number>** and click **Port Acquire**, as shown in [Figure 5-4](#).

Figure 5-4. Acquire Device from PSoC Creator

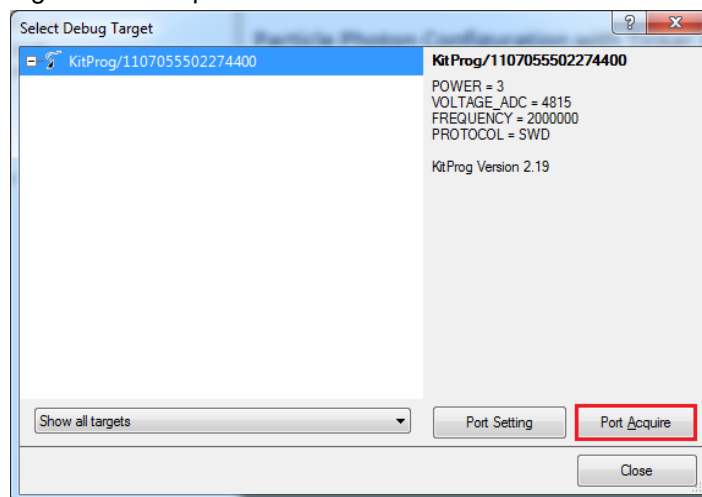

- After the device is acquired, it is shown in a tree structure below the **KitProg/<serial_number>**. Now, click the **Connect** button.

Figure 5-5. Connect Device from PSoC Creator

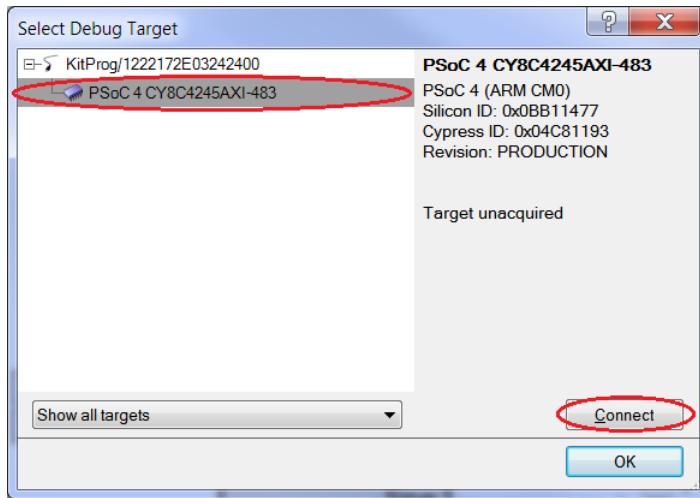

- Click **OK** to exit the window and start programming.

Figure 5-6. Program Device from PSoC Creator

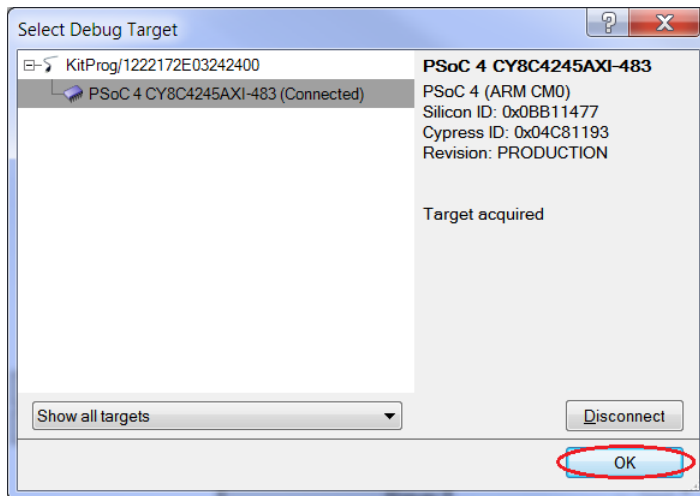

5.2 Blinking LED

5.2.1 Project Description

This code example uses a pulse-width modulator (PWM) to illuminate the RGB LED. The PWM output is connected to pin P0_3 (blue) of the RGB LED. The frequency of blinking is set to 1 Hz with a duty cycle of 50 percent. The blinking frequency and duty cycle can be varied by varying the period and compare value respectively.

Note: The PSoC 4 Pioneer Kit is factory-programmed with this example.

Figure 5-7. PSoC Creator Schematic Design of Blinking LED Project

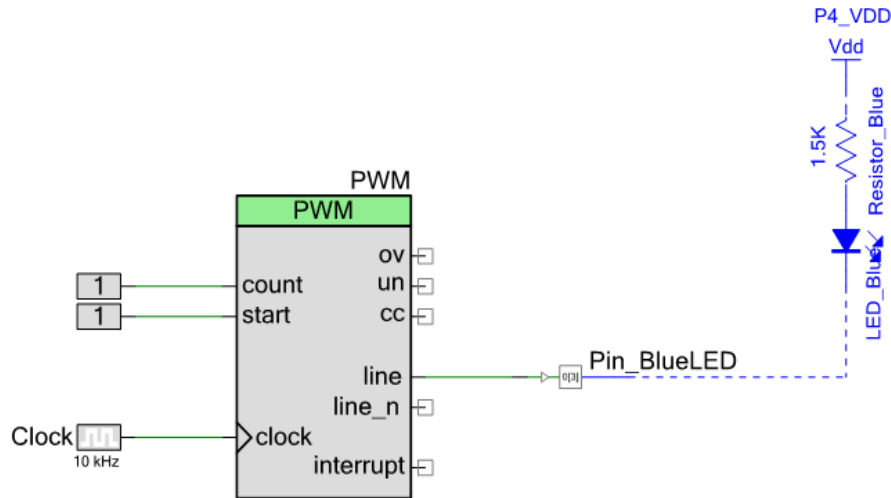

5.2.2 Hardware Connections

No specific hardware connections are required for this example because all connections are hard-wired on the board. Open *Blinking LED.cydwr* in the Workspace Explorer and select the suitable pin.

Table 5-1. Pin Connection

Pin Name	Port Name
Pin_BlueLED	P0_3 (Blue)

Figure 5-8. Pin Selection for Blinking LED Project

Name	Port	Pin	Lock
Pin_BlueLED	P0 [3]	27	<input checked="" type="checkbox"/>

5.2.3 Flow Chart

Figure 5-9 shows the flow chart of code implemented in *main.c*.

Figure 5-9. Blinking LED Code Example Flow Chart

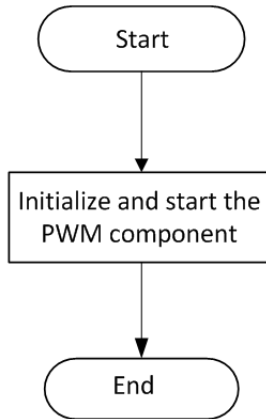

5.2.4 Verify Output

Build and program the code example onto the device. Observe the frequency and duty cycle of the blinking LED. Change the period and compare value in the PWM component, as shown in Figure 5-10. Rebuild and reprogram the device to vary the frequency and duty cycle.

Figure 5-10. PWM Component Configuration Window

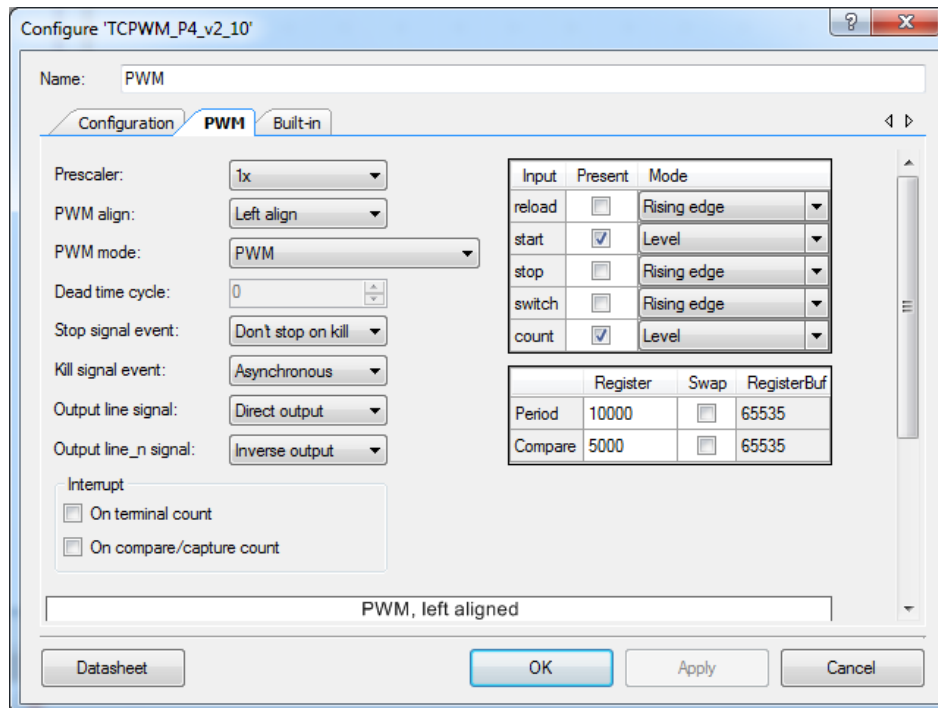

5.3 PWM

5.3.1 Project Description

This code example demonstrates the use of the PWM component. The project uses three PWM outputs to set the color of RGB LED on the kit. The LED cycles through seven colors – violet > indigo > blue > green > yellow > orange > red (VIBGYOR). Each color is maintained for a duration of one second. The different colors are achieved by changing the pulse width of the PWMs.

Figure 5-11. PSoC Creator Schematic Design of PWM Code Example

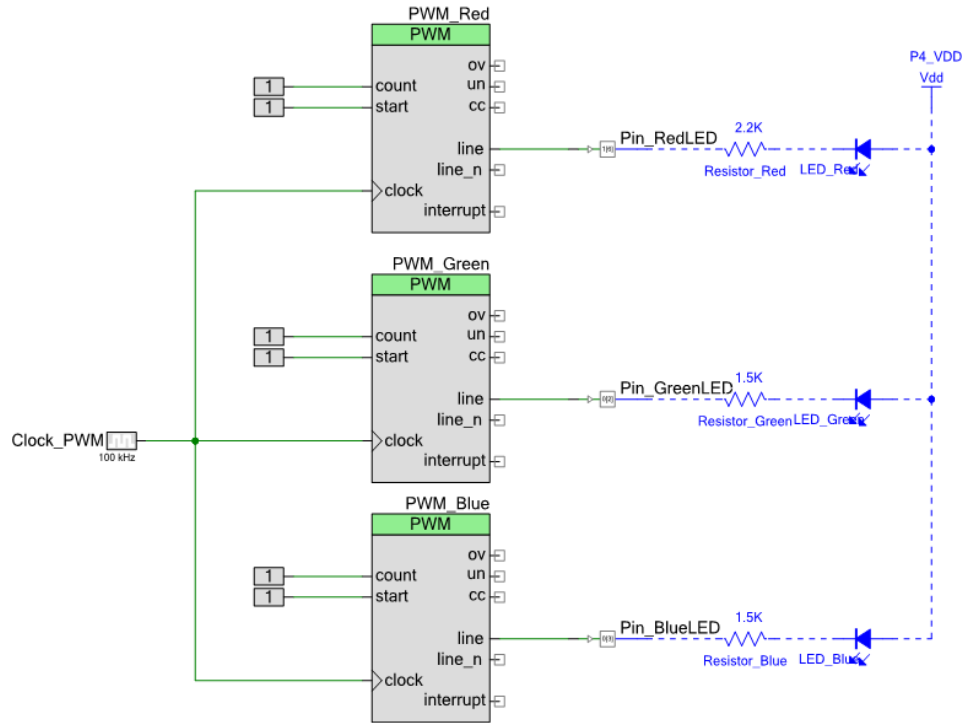

5.3.2 Hardware Connections

No specific hardware connections are required for this code example because all connections are hard-wired on the board. Open *PWM.cydwr* in the Workspace Explorer and select the suitable pins.

Table 5-2. Pin Connections

Pin Name	Port Name
Pin_RedLED	P1_6 (Red)
Pin_GreenLED	P0_2 (Green)
Pin_BlueLED	P0_3 (Blue)

Figure 5-12. Pin Selection for PWM Project

Name	Port	Pin	Lock
Pin_RedLED	P1 [6]	43	<input checked="" type="checkbox"/>
Pin_BlueLED	P0 [3]	27	<input checked="" type="checkbox"/>
Pin_GreenLED	P0 [2]	26	<input checked="" type="checkbox"/>

5.3.3 Flow Chart

Figure 5-13 shows the flow chart of code implemented in *main.c*.

Figure 5-13. PWM Code Example Flow Chart

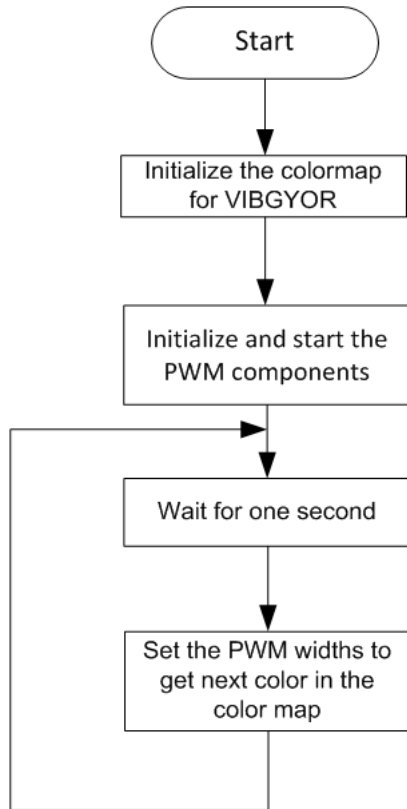

5.3.4 Verify Output

Build and program the code example, and reset the device. Observe the RGB LED cycles through the following color pattern:

violet > indigo > blue > green > yellow > orange > red (VIBGYOR)

5.4 Deep Sleep

5.4.1 Project Description

This code example demonstrates the low-power functionality of the PSoC 4. The LED is turned on for one second to indicate Active mode; then, the device enters Deep-Sleep mode. When switch SW2 is pressed, the device wakes up and the LED is turned on for one second and then goes back into Deep-Sleep mode.

Figure 5-14. PSoC Creator Schematic Design of Deep-Sleep Project

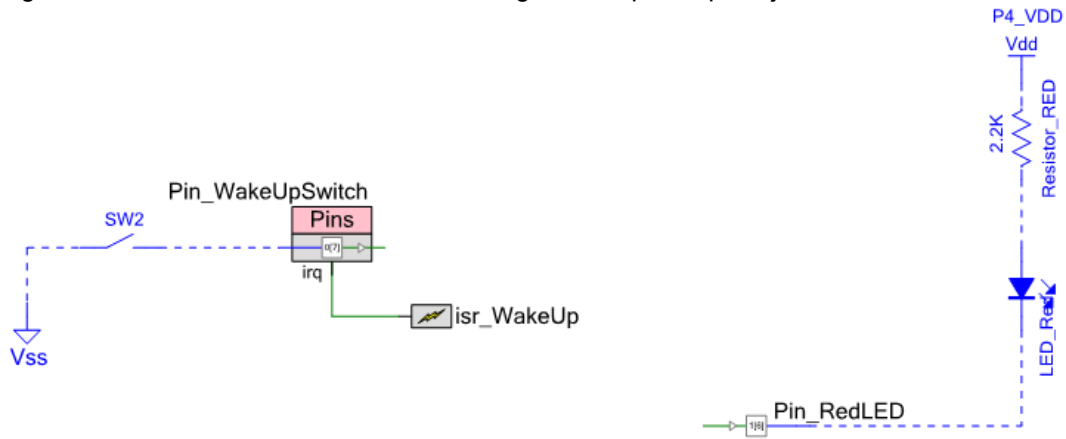

5.4.2 Hardware Connections

No extra connections are required for the code example functionality because the connections are hard-wired onto the board. To make low-power measurements using this project, refer to the use case detailed in section [Procedure to Measure PSoC 4 Current Consumption on page 34](#).

Open *Deep Sleep.cydwr* in the Workspace Explorer and select the suitable pin.

Table 5-3. Pin Connection

Pin Name	Port Name
Pin_RedLED	P1_6 (Red)
Pin_WakeUpSwitch	P0_7

Figure 5-15. Pin Selection for Deep-Sleep Project

	Name	Port	Pin	Lock
<input checked="" type="checkbox"/>	Pin_RedLED	P1 [6]	43	<input checked="" type="checkbox"/>
<input checked="" type="checkbox"/>	Pin_WakeUpSwitch	P0 [7]	31	<input checked="" type="checkbox"/>

Note that the Debug (SWD) port is disabled in the example to reduce power consumption during Deep-Sleep power mode. The Debug port can be enabled by setting the **Debug Select** option to **SWD** in the **System** tab of the *.cydwr* file, as shown in [Figure 5-16](#). Disabling the debug port disables the ability to debug the code example through SWD.

Figure 5-16. Enable Debug Select

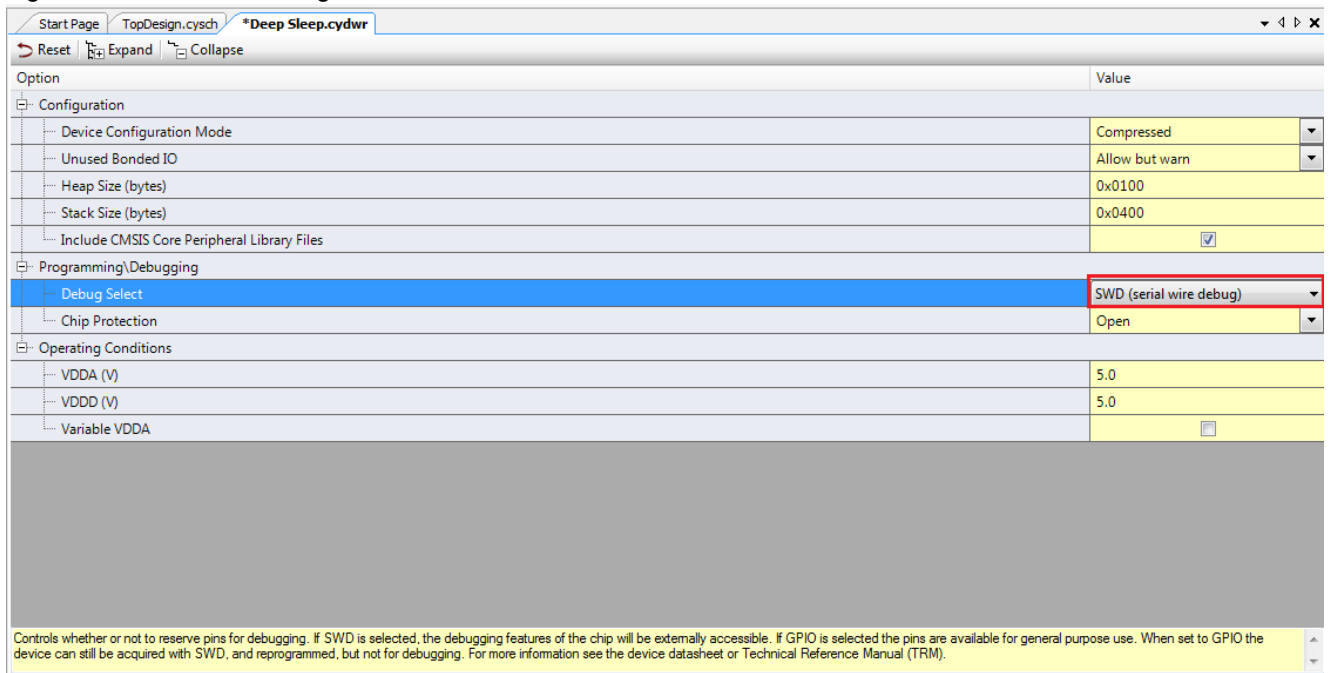

Option	Value
[-] Configuration	
Device Configuration Mode	Compressed
Unused Bonded IO	Allow but warn
Heap Size (bytes)	0x0100
Stack Size (bytes)	0x0400
Include CMSIS Core Peripheral Library Files	<input checked="" type="checkbox"/>
[-] Programming\Debugging	
Debug Select	SWD (serial wire debug)
Chip Protection	Open
[-] Operating Conditions	
VDDA (V)	5.0
VDDD (V)	5.0
Variable VDDA	<input type="checkbox"/>

Controls whether or not to reserve pins for debugging. If SWD is selected, the debugging features of the chip will be externally accessible. If GPIO is selected the pins are available for general purpose use. When set to GPIO the device can still be acquired with SWD, and reprogrammed, but not for debugging. For more information see the device datasheet or Technical Reference Manual (TRM).

5.4.3 Flow Chart

Figure 5-17 shows the flow chart of code implemented in *main.c*.

Figure 5-17. Deep-Sleep Project Flow Chart

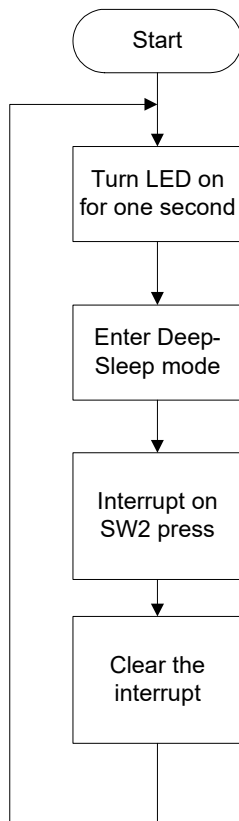

5.4.4 Verify Output

Build and program the code example, and reset the device. LED is on for one second and turns off, which indicates that the device has entered Deep-Sleep mode. Press SW2 switch to wake up the device from Deep-Sleep mode and enter Active mode. The device goes back to Deep-Sleep mode after one second.

Note: When the device is in Deep-Sleep mode, the programmer must reacquire the device before programming can start.

5.5 CapSense

This code example can be executed in two ways – with and without CapSense tuning. The same project can be used to demonstrate the CapSense functionality as well as CapSense tuning using the Tuner Helper GUI in PSoC Creator. This is done by commenting and uncommenting the line `#define ENABLE_TUNER` in the `main.c` file of the code example. PSoC Creator does not compile the code under the `#ifdef` (if defined) statement when the `#define` statement is commented (`/*.....*/` or `//`). Similarly, when the `#define` statement is uncommented, the code required for working with Tuner GUI is compiled. By default, the project is set to work without CapSense tuning by commenting the `#define`.

5.5.1 CapSense (Without Tuning)

5.5.1.1 Project Description

This code example demonstrates CapSense on PSoC 4. The example uses the five-segment CapSense slider on the board. Each capacitive sensor on the slider is scanned using Cypress’s CapSense Sigma Delta (CSD) algorithm implemented in the CapSense component. This project is pre-tuned to take care of the board parasitics. For more information on the CapSense component and CapSense tuning, see the CapSense component datasheet in PSoC Creator.

In this code example, the brightness of the green and red LEDs are varied, based on the position of the user’s finger on the CapSense slider.

Figure 5-18. PSoC Creator Schematic Design of CapSense Code Example

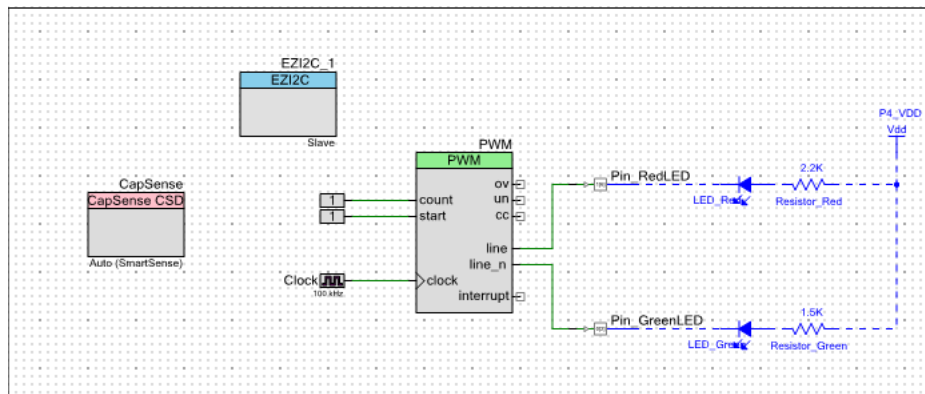

Note: The Ez12C component is not used when tuning is disabled.

5.5.1.2 Hardware Connections











No specific hardware connections are required for this code example because all connections are hard-wired on the board. Open *CapSense.cydwr* in the Workspace Explorer and select the suitable pins.

Table 5-4. Pin Connection

Pin Name	Port Name
CapSense:Cmod	P4_2
CapSense:Sns[0]	P1_1
CapSense:Sns[1]	P1_2
CapSense:Sns[2]	P1_3
CapSense:Sns[3]	P1_4
CapSense:Sns[4]	P1_5
Pin_GreenLED	P0_2 (Green)
Pin_RedLED	P1_6 (Red)
EZI2C_1:scl	P3_0 (SCL)
EZI2C_1:sda	P3_1 (SDA)

Note: The I2C communication lines are not used when tuning is disabled.

Figure 5-19. Pin Selection for CapSense Code Example

	Name	Port	Pin
	\CapSense:Cmod\ (Cmod)	P4[2]	22
	\CapSense:Sns[0]\ (LinearSlider0_e0_LS)	P1[1]	38
	\CapSense:Sns[1]\ (LinearSlider0_e1_LS)	P1[2]	39
	\CapSense:Sns[2]\ (LinearSlider0_e2_LS)	P1[3]	40
	\CapSense:Sns[3]\ (LinearSlider0_e3_LS)	P1[4]	41
	\CapSense:Sns[4]\ (LinearSlider0_e4_LS)	P1[5]	42
	\EZI2C_1:scl\	P3[0]	11
	\EZI2C_1:sda\	P3[1]	12
	Pin_GreenLED	P0[2]	26
	Pin_RedLED	P1[6]	43

5.5.1.3 Flow Chart

Figure 5-20 shows the flow chart of code implemented in *main.c*.

Figure 5-20. CapSense Project Flow Chart

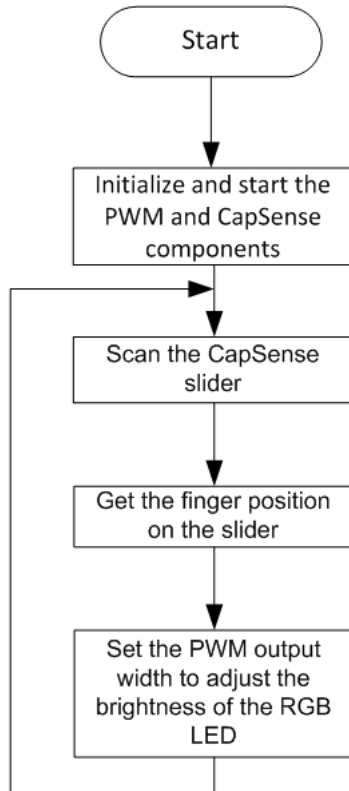

5.5.1.4 Verify Output

The brightness of the green and red LEDs are varied based on the position of the user’s finger on the CapSense slider. When the finger is on segment 5 (P1[5]) of the slider, the green LED is brighter than the red LED; when the finger is on segment 1 (P1[1]) of the slider, the red LED is brighter than the green LED.

5.5.2 CapSense (With Tuning)

5.5.2.1 *Project Description*

This code example demonstrates CapSense tuning on PSoC 4 using the “Tuner” to monitor CapSense outputs. The CapSense outputs such as rawcounts, baseline, and signal (difference count) can be monitored on the Tuner GUI. The project uses the auto-tuning feature, which sets all CapSense parameters to the optimum values automatically. The parameter settings can be monitored in the GUI but cannot be altered. In the manual tuning method, parameter settings can be changed in the GUI and the resulting output can be seen.

The code example uses the five-segment CapSense slider on the board. Each capacitive sensor on the slider is scanned using Cypress's CapSense Sigma Delta (CSD) algorithm implemented in the CapSense component. The code uses tuner APIs. The tuner API `CapSense_TunerComm()` is used in the main loop to scan sensors, which also sends the CapSense variables RawCounts, Baseline, and Difference Counts (Signal) to the PC GUI through I2C communication.

In this example, the brightness of the green and red LEDs are varied, based on the position of the user's finger on the CapSense slider.

See [Figure 5-18](#) for the project schematic.

5.5.2.2 *Hardware Connections*

No specific hardware connections are required for this code example because all connections are hard-wired on the board. Open `CapSense.cydwr` in the Workspace Explorer and select the suitable pins.

See [Table 5-4](#) and [Figure 5-19](#) for the CapSense project pin connections.

5.5.2.3 Flow Chart

Figure 5-21. CapSense with Tuning Flow Chart

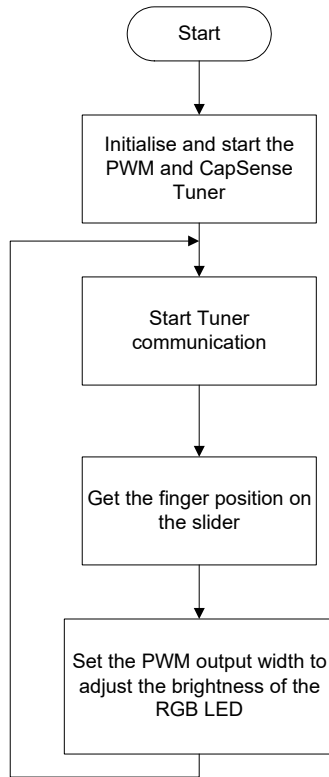

5.5.2.4 Launching Tuner GUI

The Tuner GUI from PSoC Creator should be up and running for the code example to work. To launch the GUI follow these steps:

1. Go to the project's *TopDesign.cysch* file.

Figure 5-22. Top Design File

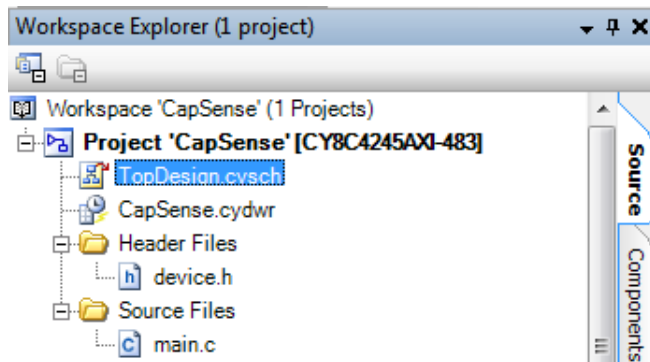

2. To open the tuner, right-click on the CapSense_CSD component in PSoC Creator and click **Launch Tuner**.

Figure 5-23. Launch Tuner

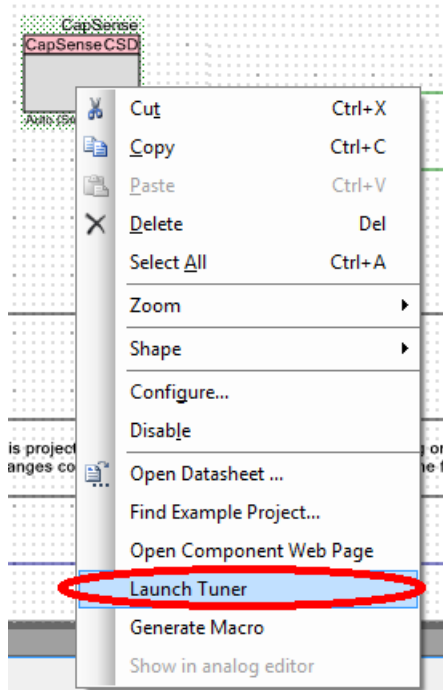

3. The Tuner GUI opens. Click **Configuration** to open the configuration window.

Figure 5-24. Tuner GUI

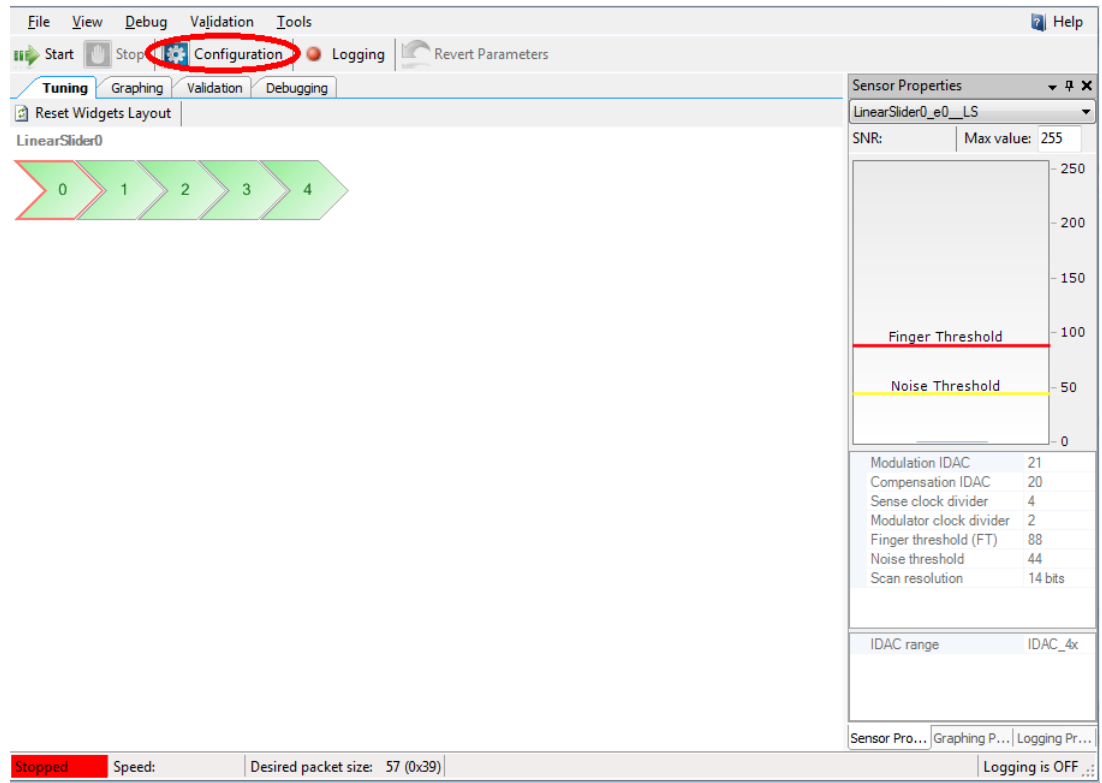

4. Set the I2C communication parameters, as shown in the following figure.

Figure 5-25. I2C Communication

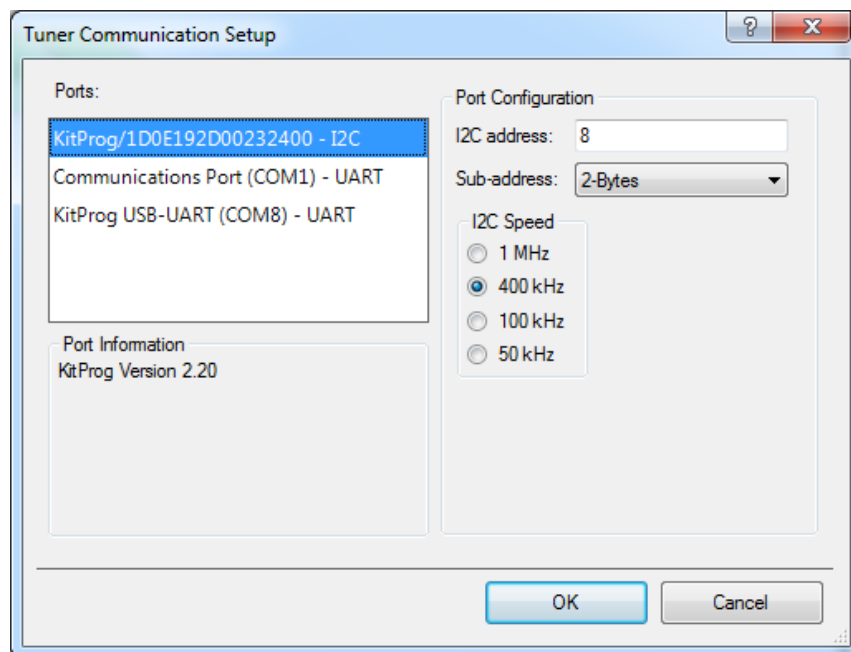

5. Click **OK** to apply the settings.

5.5.2.5 Verify Output

1. To start the scanning and communication process, click **Start**.

Figure 5-26. Start Communication

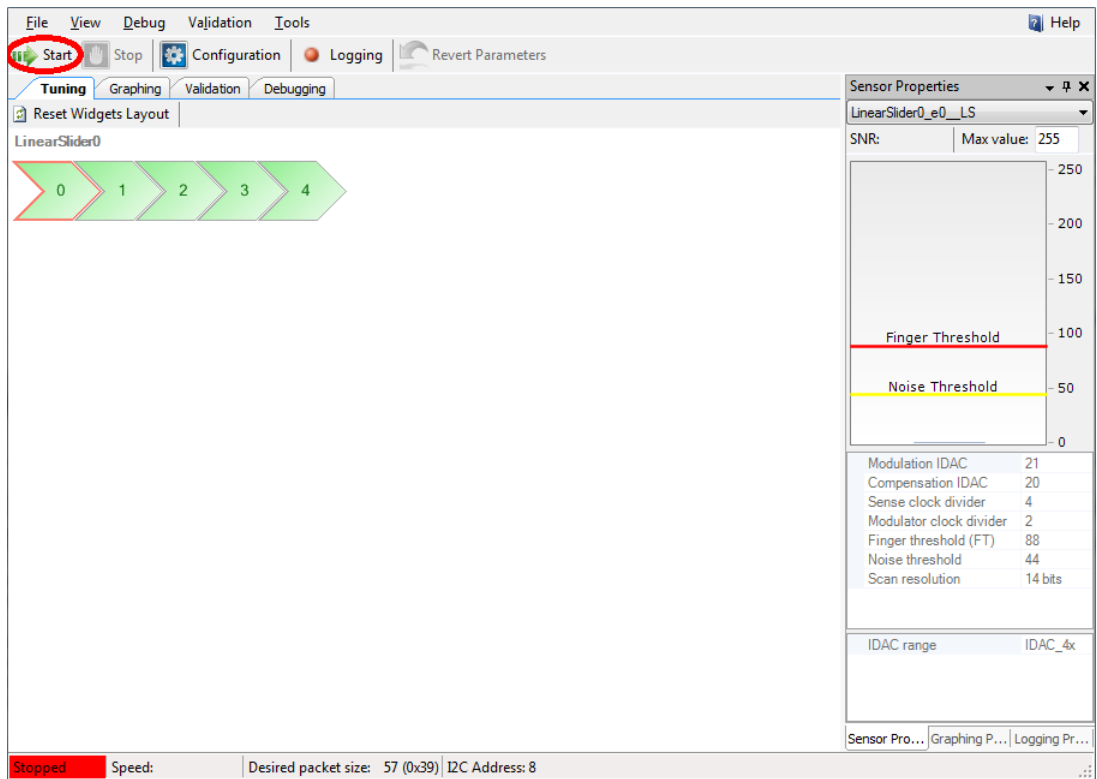

2. Select a sensor in the Tuning tab. A red outline is seen on the selected sensor. Different CapSense parameters are shown in Sensor Properties tab on the bottom-right. You cannot edit the settings because auto-tuning is used in this project; auto-tuning automatically sets all the parameters. Touch the selected sensor and observe the response in the tuner window.

Note: The board is designed according to layout guidelines for CapSense (best practices) for 1.5-mm overlay. Therefore, it is recommended that an overlay (not shipped with the kit) be used while using the CapSense code example with tuning.

Figure 5-27. Sensor Tuning

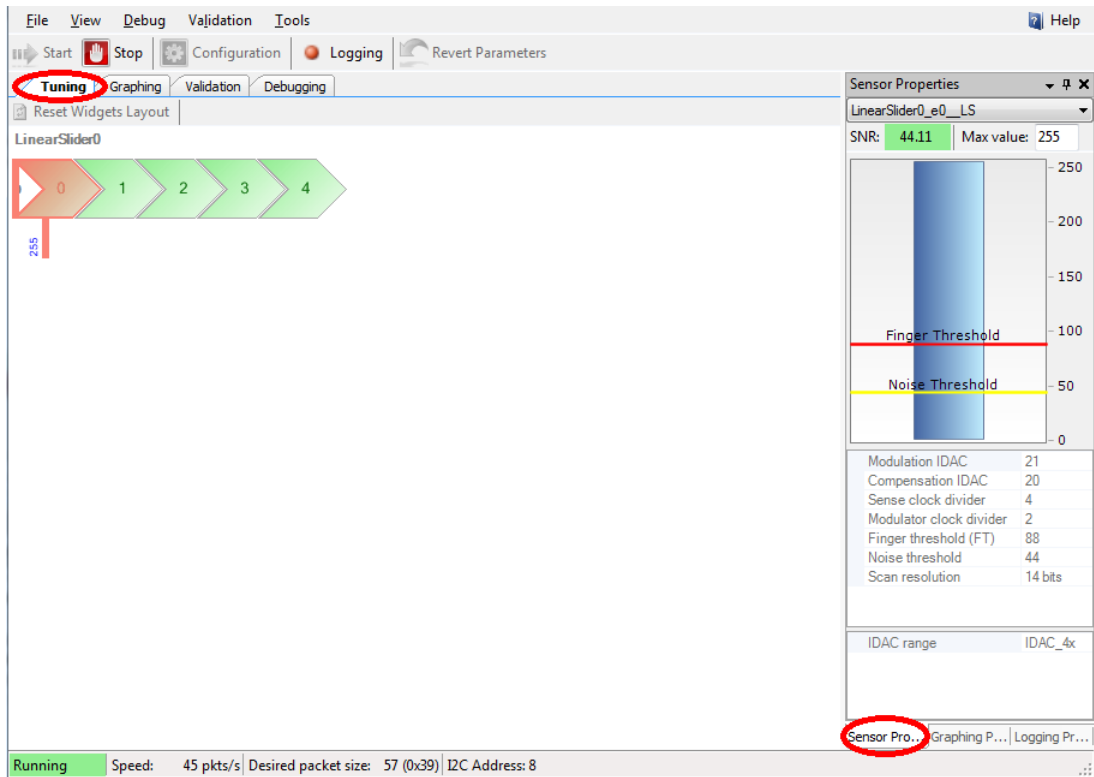

3. In the Graphing tab, the CapSense results: Raw counts, Baseline, Signal (difference count) and On/Off status for each sensor are represented as a graph. Click the **Graphing Properties** tab on the bottom-right to select the slider element for which the CapSense results are to be shown in the Graphing tab.

- Select the sensor parameters to observe, as shown in the following figure. The graph of the selected parameters is shown.

Figure 5-28. Sensor Parameter Graph

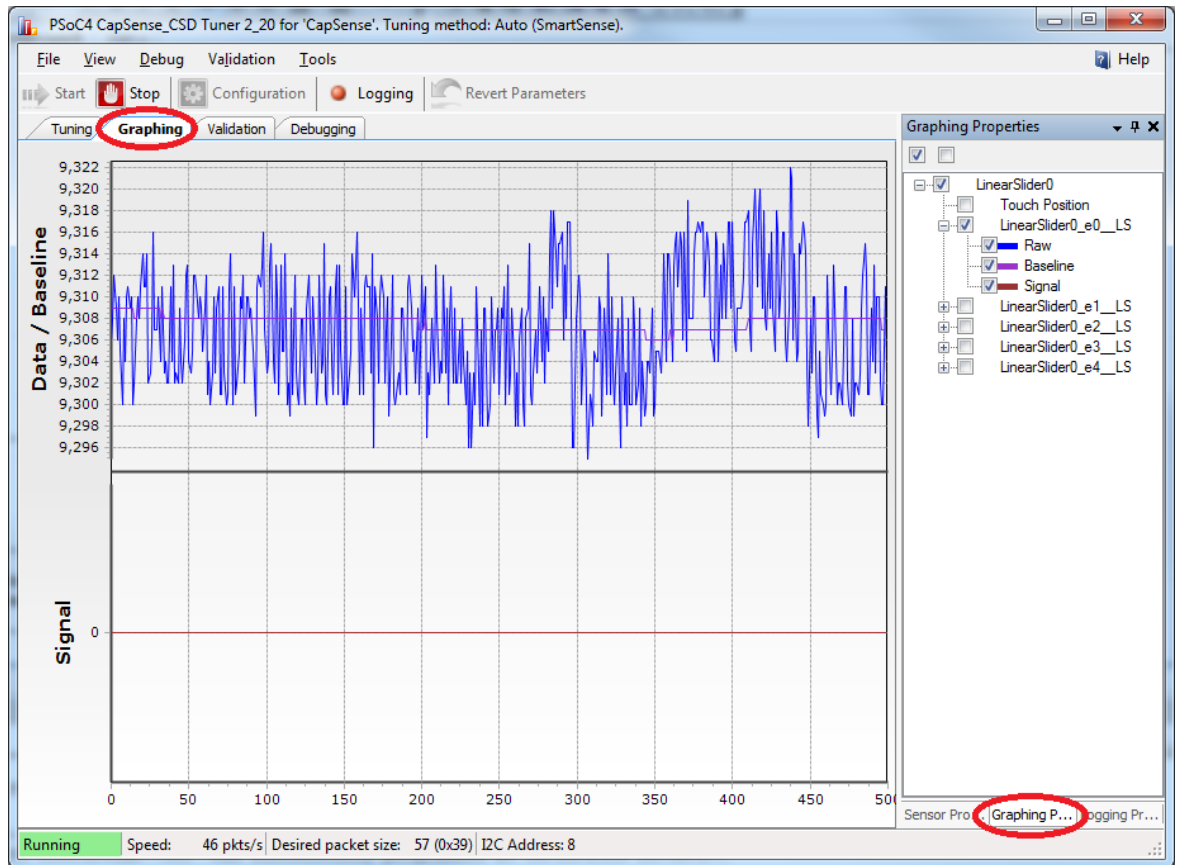

5. Touch a sensor or slider element and see the increase in raw counts.

Figure 5-29. Raw Count Increase

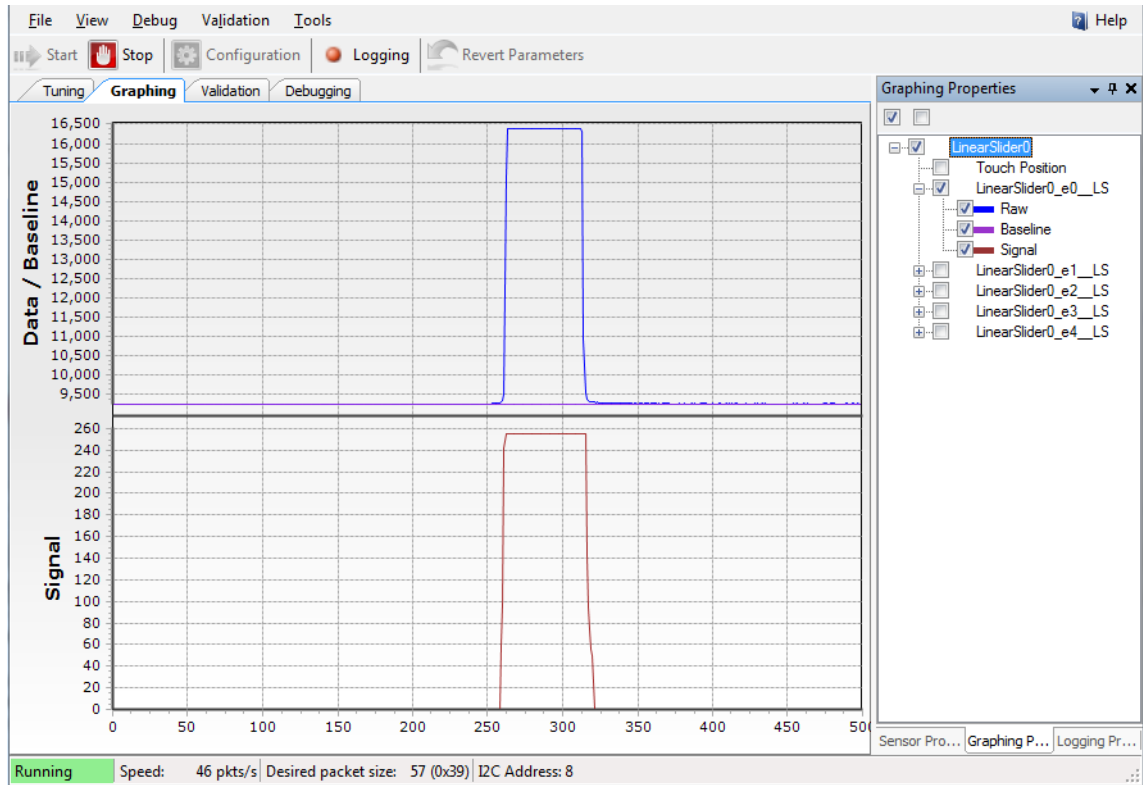

6. Advanced Topics



6.1 Using PSoC 5LP as a USB-UART Bridge

The PSoC 5LP serves as a USB-UART bridge, which can communicate with the COM terminal software. This section explains how to create a PSoC 4 code example to communicate with the COM terminal software. This project is available with other code examples for the PSoC 4 Pioneer Kit at the [element14](#) webpage, [100 Projects in 100 days](#).

Users who have a Windows operating system that does not have HyperTerminal can use an alternate terminal software such as [PuTTY](#).

1. Create a new CY8CKIT-042 (PSoC 4200) Kit project in PSoC Creator, as shown in the following figures. Select a specific location for your project and name the project as desired. You must select the appropriate target hardware (kit) for this project. Ensure that the **Select project template** option is set to 'Empty schematic'. This example uses PSoC 4200 as the target device and CY8CKIT-042 as the target board.

Figure 6-1. Select Project Type

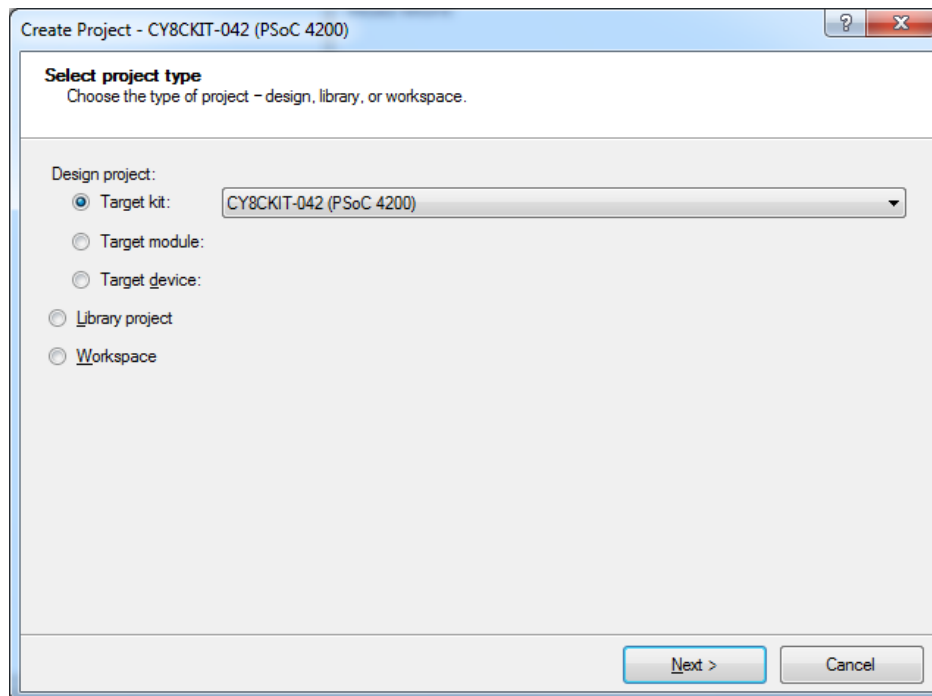

Figure 6-2. Select Empty Schematic Option

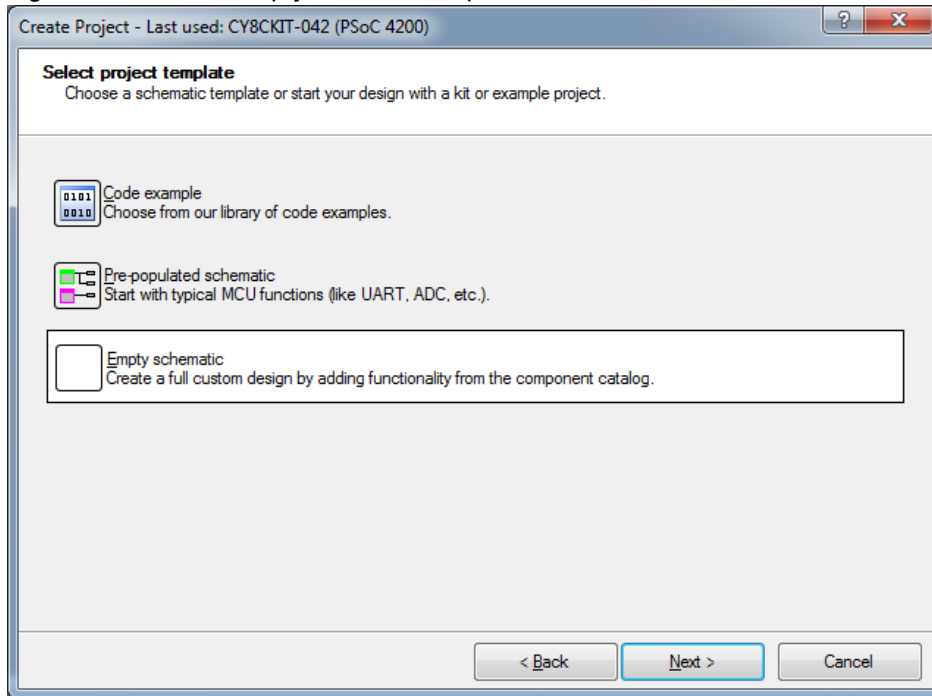
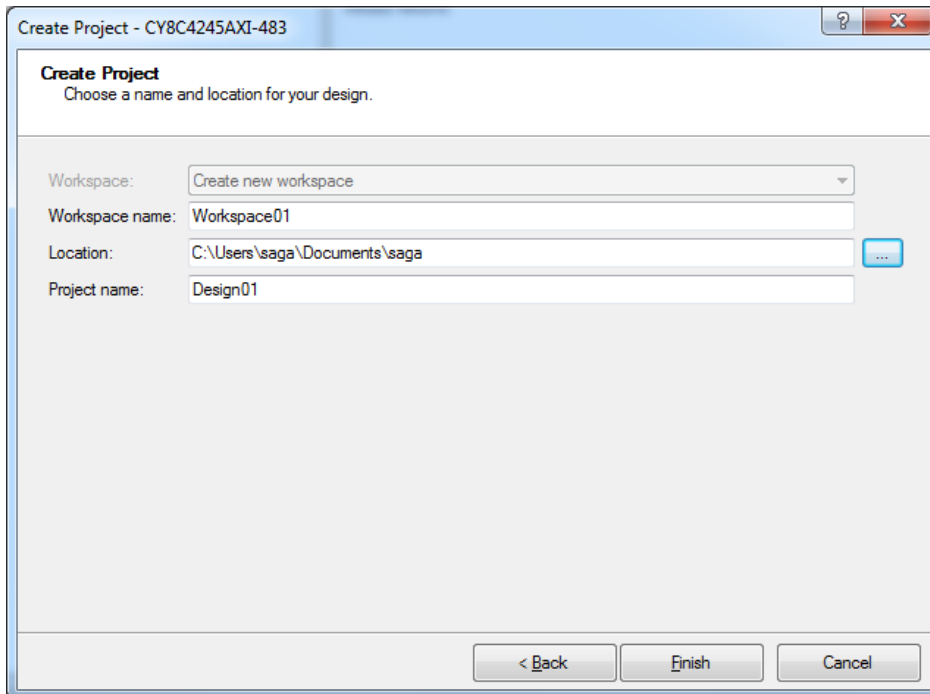
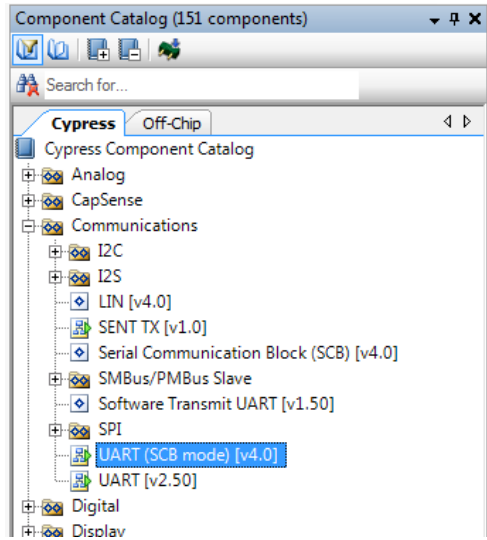

Figure 6-3. Create Project



2. Drag and drop a UART (SCB) component to the top design.

Figure 6-4. UART Component Under Component Catalog



3. To configure the UART, double-click or right-click on the UART component and select **Configure**.

Figure 6-5. Open UART Configuration Window

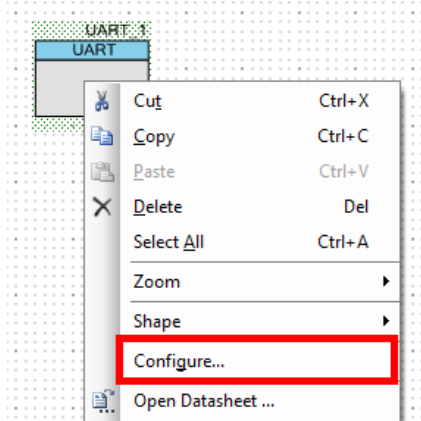

4. Change the component name from UART_1 to UART.

5. Configure the UART as shown in the following figures.

Figure 6-6. UART Configuration Window

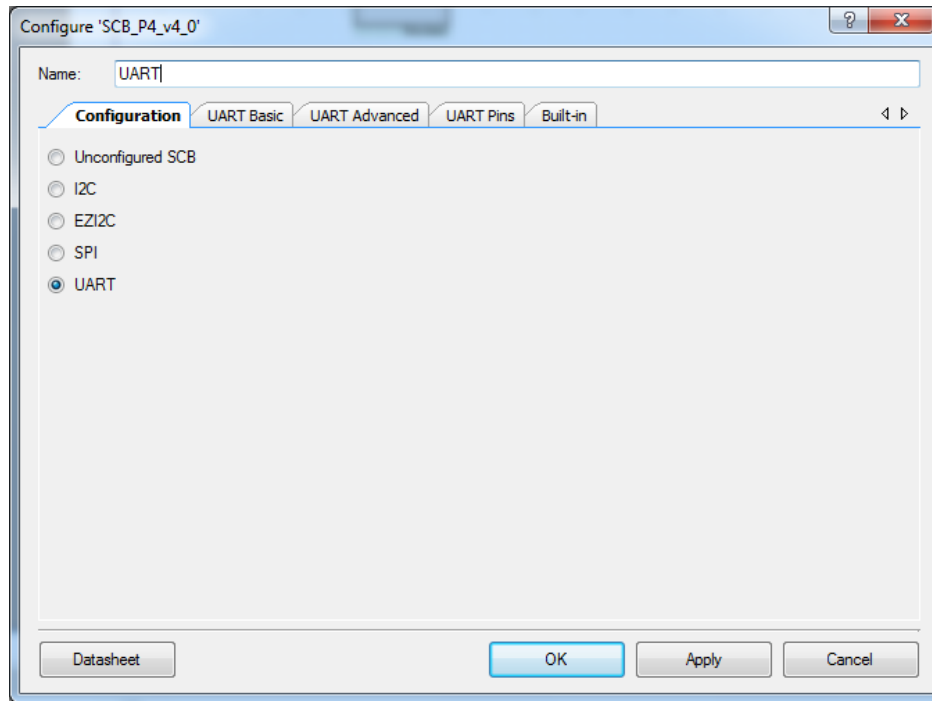

Figure 6-7. UART Basic Configuration Window

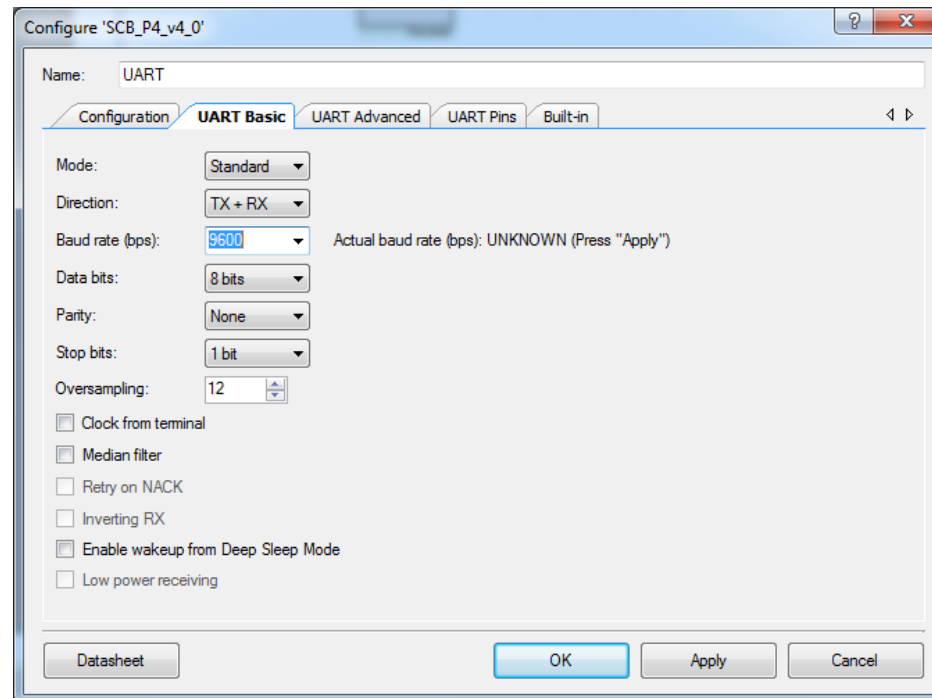
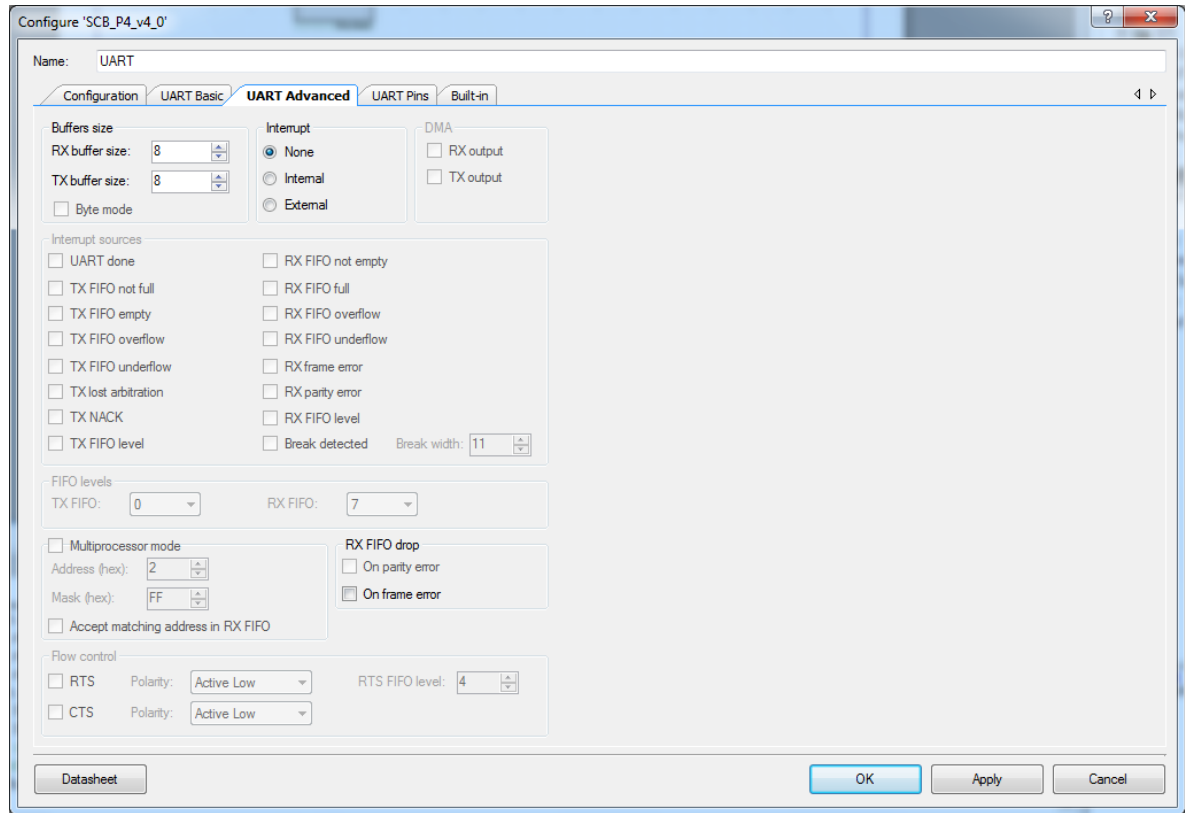

Figure 6-8. UART Advanced Configuration Window



6. Click **Apply** and then **OK** to save the changes made to UART configuration.
7. Select **P0[4]** for UART RX and **P0[5]** for UART TX in the **Pins** tab of <Project.cydwr>.

Figure 6-9. Pin Selection

	Name	Port	Pin	Lock
<input checked="" type="checkbox"/>	\UART: rx\	P0 [4]	28	<input checked="" type="checkbox"/>
<input checked="" type="checkbox"/>	\UART: tx\	P0 [5]	29	<input checked="" type="checkbox"/>

8. Place the following code in your *main.c* project file. The code will echo any UART data received.

```
int main()
{
    uint8 ch;

    /* Start SCB UART TX+RX operation */
    UART_Start();

    /* Transmit String through UART TX Line */
    UART_UartPutString("CY8CKIT-042 USB-UART");

    for(;;)
    {
        /* Get received character or zero if nothing has been received yet
        */
        ch = UART_UartGetChar();

        if(0u != ch)
        {
            /* Send the data through UART. This functions is blocking and waits until
            there is an entry into the TX FIFO. */
            UART_UartPutChar(ch);
        }
    }
}
```

- Build the project by clicking **Build > Build {Project Name}** or **[Shift] + [F6]**. After the project is built without errors and warnings, program (by clicking **Debug > Program**) the project to PSoC 4 through the PSoC 5LP USB programmer or MiniProg3.

Connect the RX line of the PSoC 4 to J8.10 and TX line of the PSoC 4 to J8.9, as shown in the following figures.

Figure 6-10. UART Connection Between PSoC 4 and PSoC 5LP

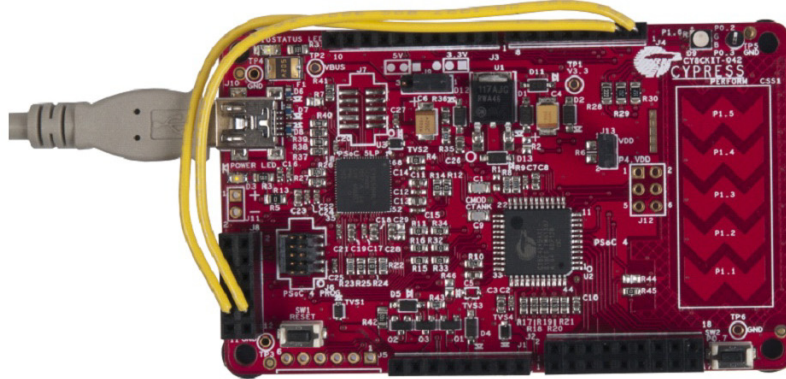
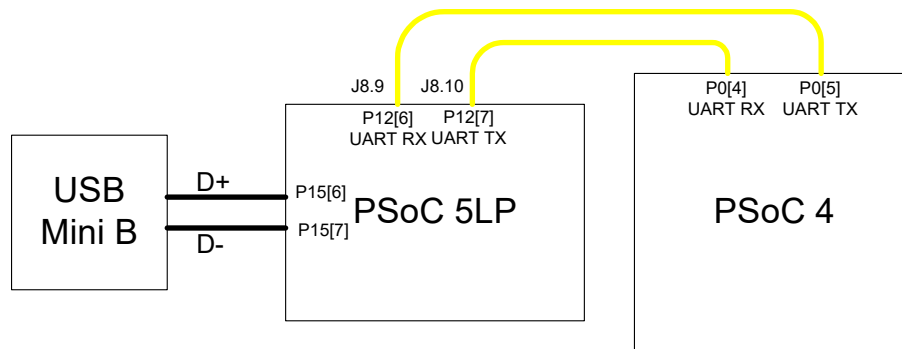

Figure 6-11. Block Diagram of UART Connection Between PSoC 4 and PSoC 5LP



Note: UART RX and UART TX can be routed to any digital pin on PSoC 4 based on the configuration of the UART component. An SCB implementation of UART will route the RX and TX pins to either one of the following subsets: (P0[4], P0[5]) or (P3[0],P3[1]) or (P4[0],P4[1]).

To communicate with the PSoC 4 from the terminal software, follow this procedure:

1. Connect USB Mini B to J10. The kit enumerates as a **KitProg USB-UART** and is available under the Device Manager, Ports (COM & LPT). A communication port is assigned to the **KitProg USB-UART**.

Figure 6-12. KitProg USB-UART in Device Manager

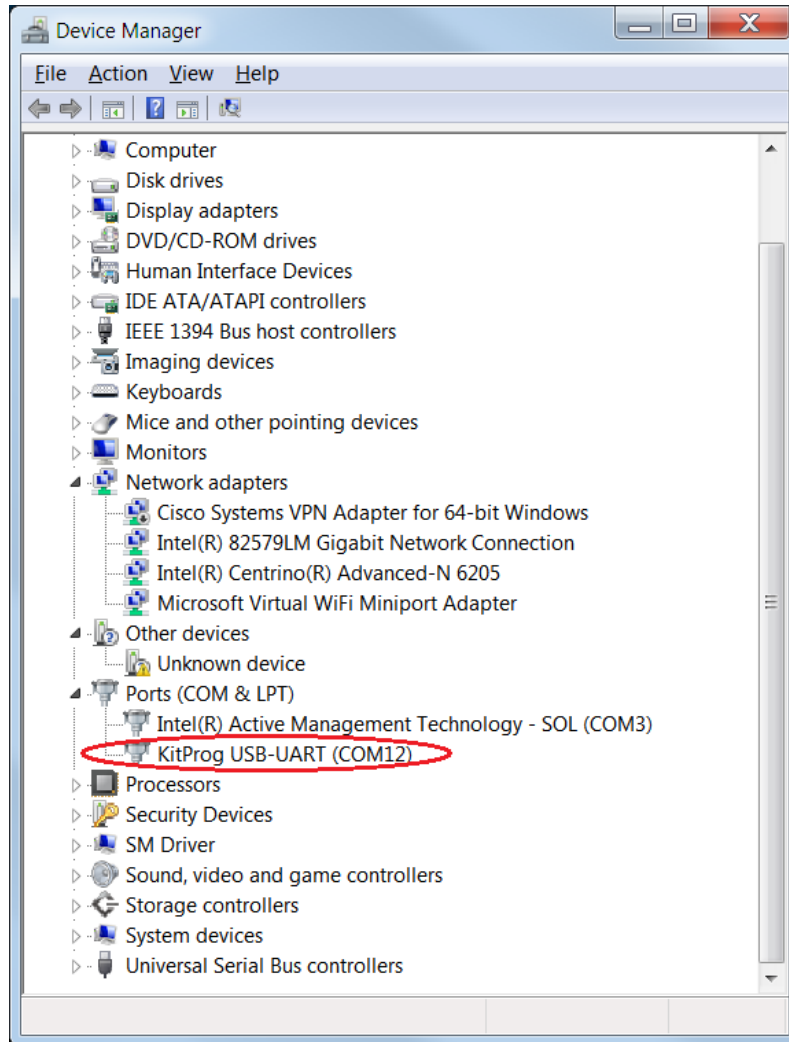

- Open HyperTerminal and select **File > New Connection** and enter a name for the new connection and click **OK**.
For PuTTY, double-click the putty icon and select **Serial** under **Connection**.

Figure 6-13. Open New Connection

HyperTerminal

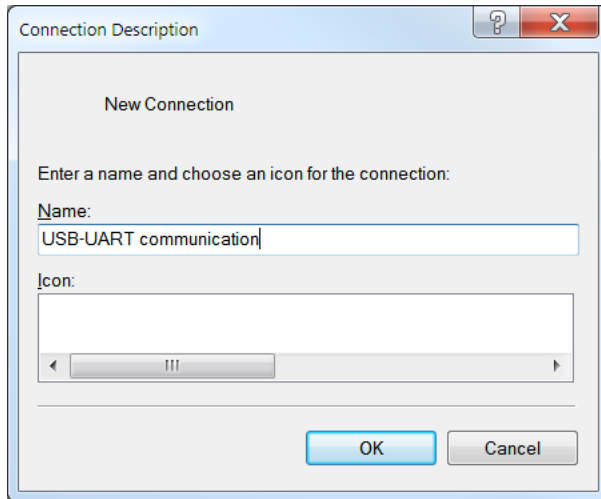

PuTTY

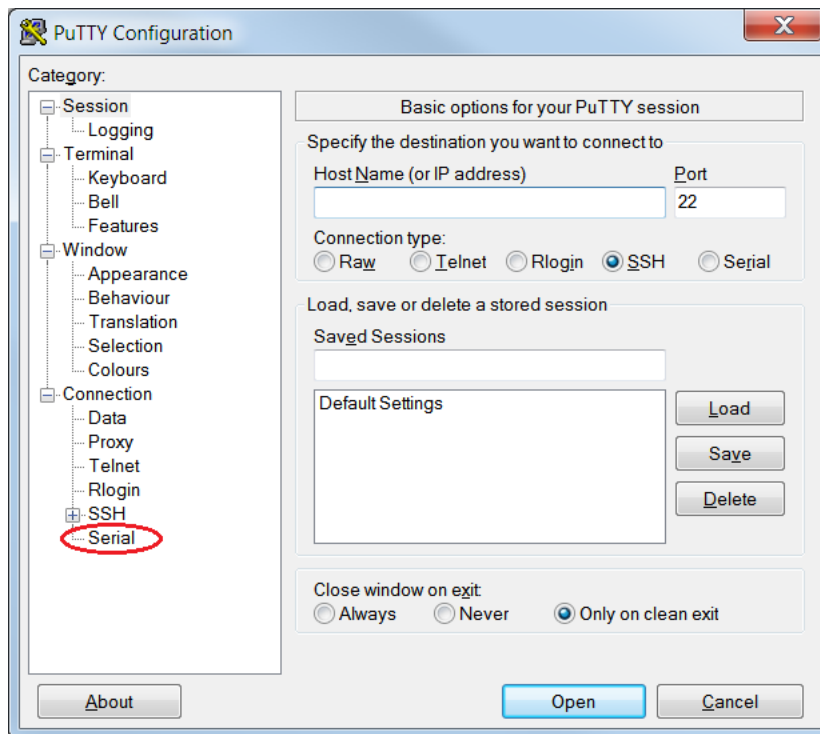

3. A new window opens, where the communication port can be selected.
 In HyperTerminal, select **COMX** (or the specific communication port that is assigned to KitProg USB-UART) in **Connect using** and click **OK**.
 In PuTTY enter the COMX in **Serial line to connect to**.
 This code example uses **COM12**.

Figure 6-14. Select Communication Port

HyperTerminal

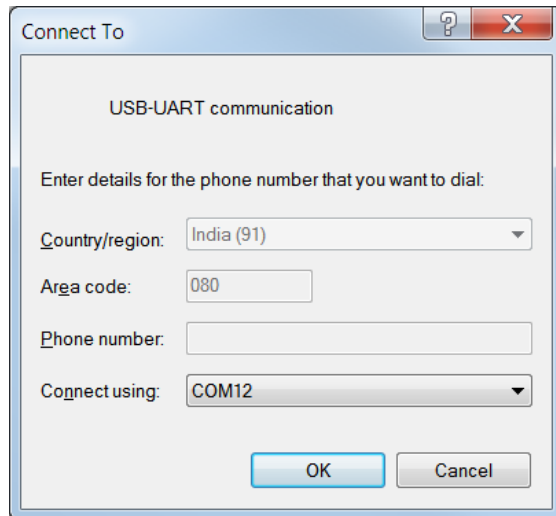

PuTTY

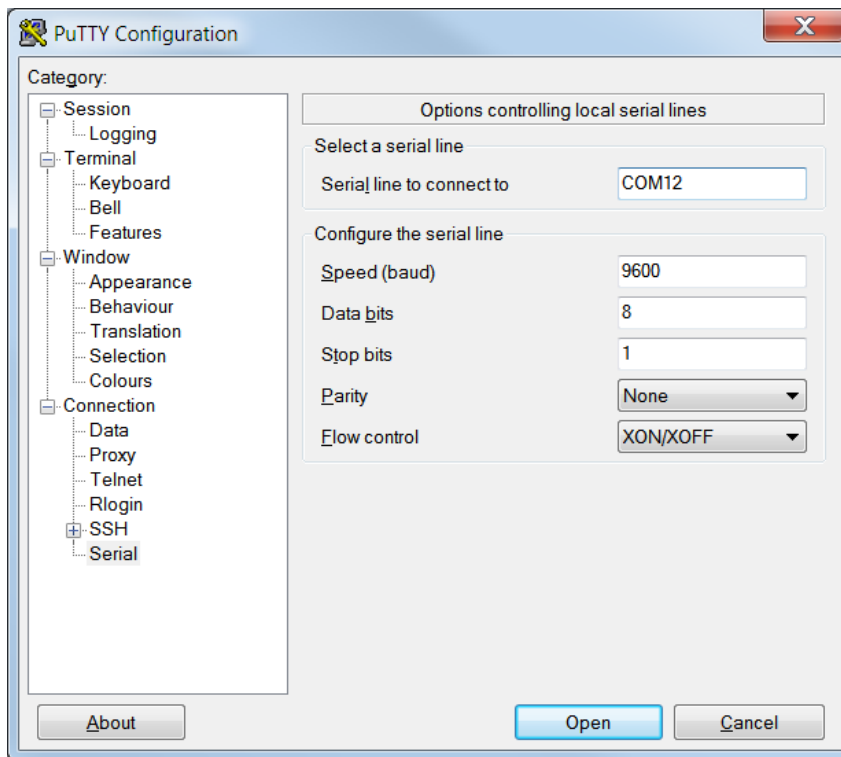

- In HyperTerminal, select 'Bits per second', 'Data bits', 'Parity', 'Stop bits', and 'Flow control' under **Port Settings** and click **OK**.

Make sure that the settings are identical to the UART settings configured for PSoC 4.

In PuTTY select 'Speed (baud)', 'Data bits', 'Stop bits', 'Parity' and 'Flow control' under **Configure the serial line**. Click **Session** and select **Serial** under **Connection type**.

Serial line shows the communication port (COM12) and **Speed** shows the baud rate selected. Click **Open** to start the communication.

Figure 6-15. Configure the Communication Port
HyperTerminal

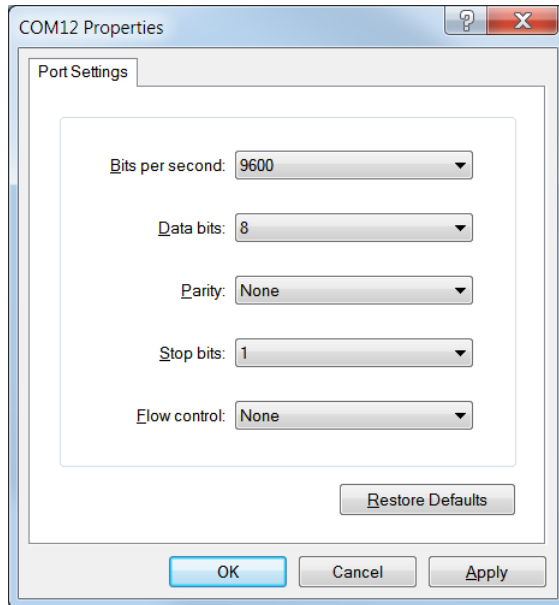

PuTTY

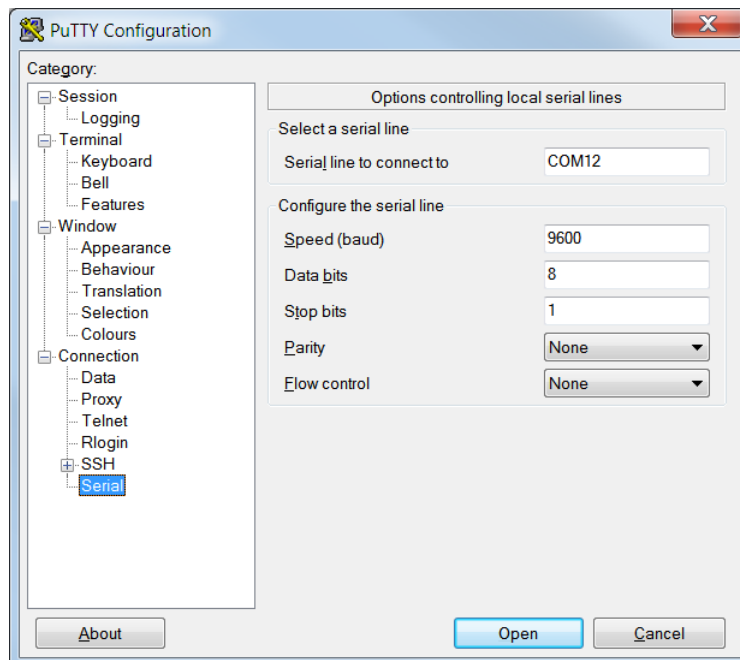
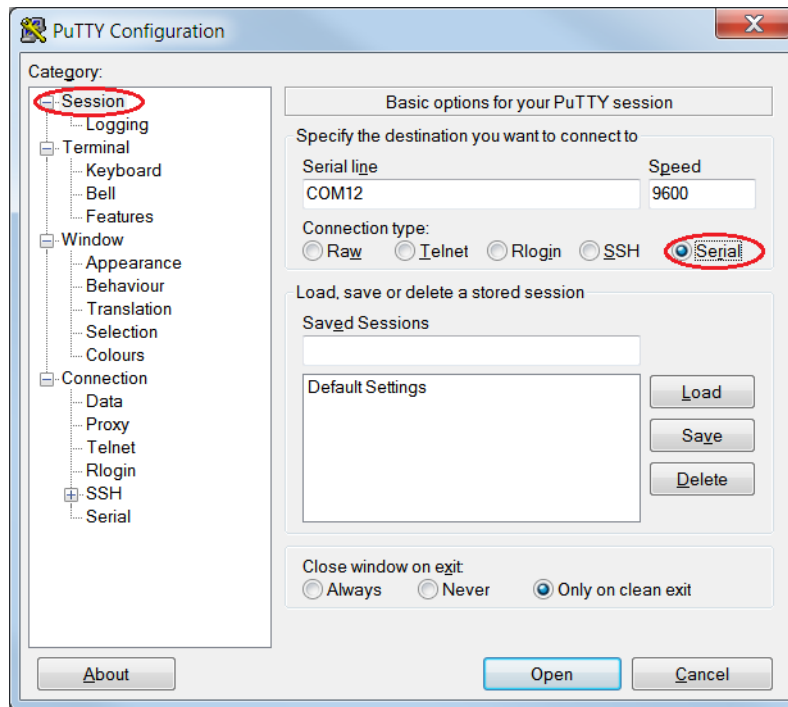

Figure 6-16. Select Communication Type in PuTTY



5. Enable **Echo typed characters locally** under **File > Properties > Settings > ASCII Setup**, to display the typed characters on HyperTerminal. In PuTTY, enable the **Force on** under **Terminal > Line discipline** options to display the typed characters on the PuTTY.

Figure 6-17. Enabling Echo of Typed Characters in HyperTerminal

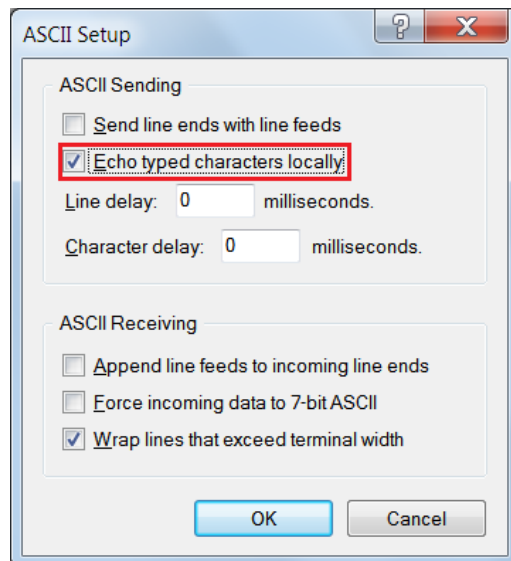
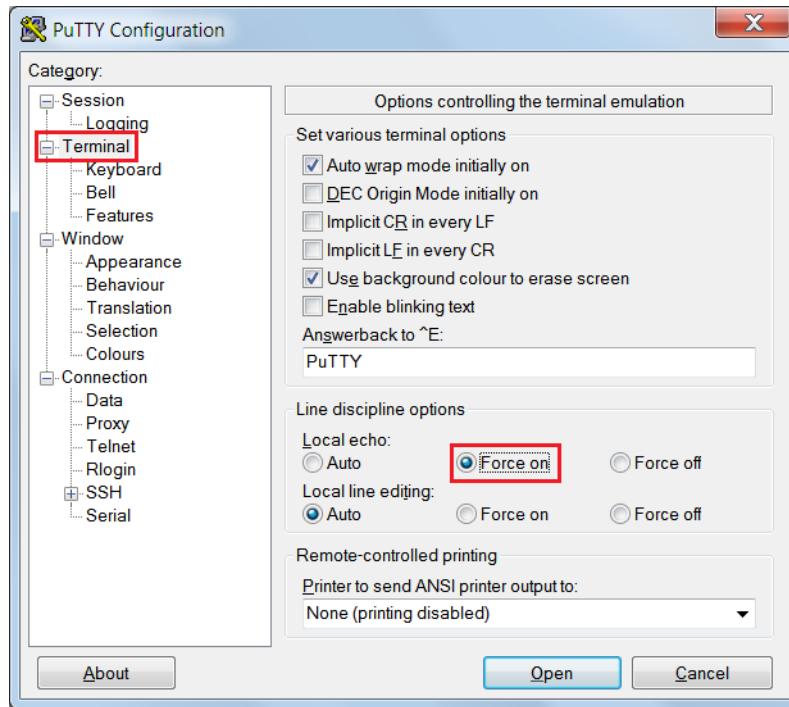

Figure 6-18. Enabling Echo of Typed Characters in PuTTY



6. The COM terminal software displays both the typed data and the looped back data from the PSoC 4 UART.

Figure 6-19. Data Displayed on HyperTerminal

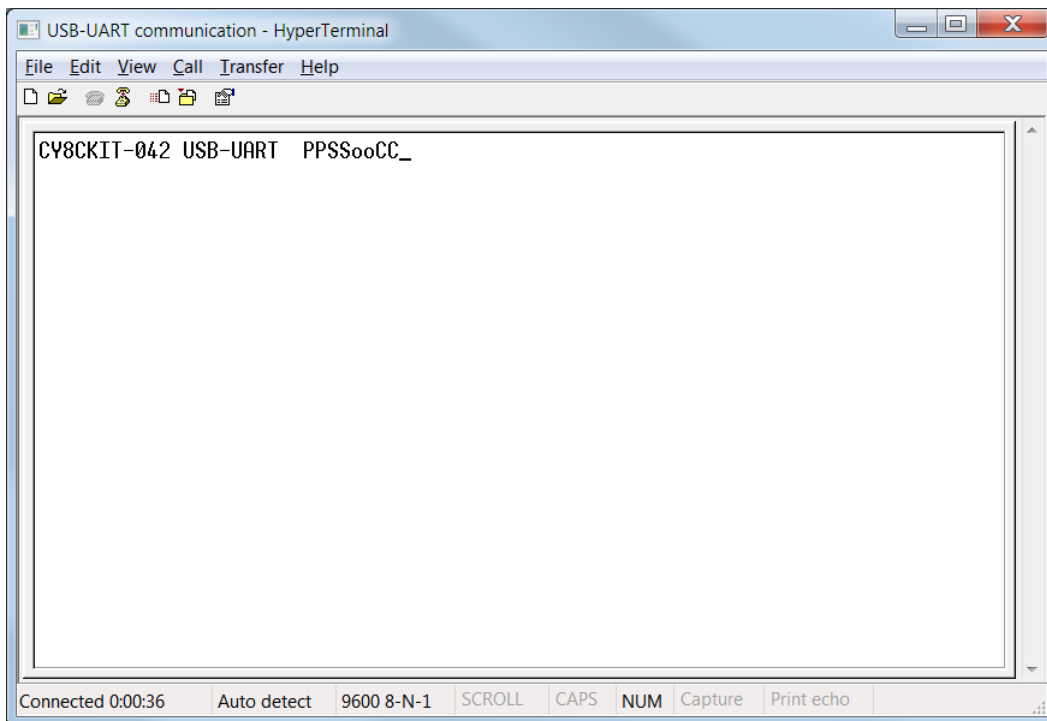
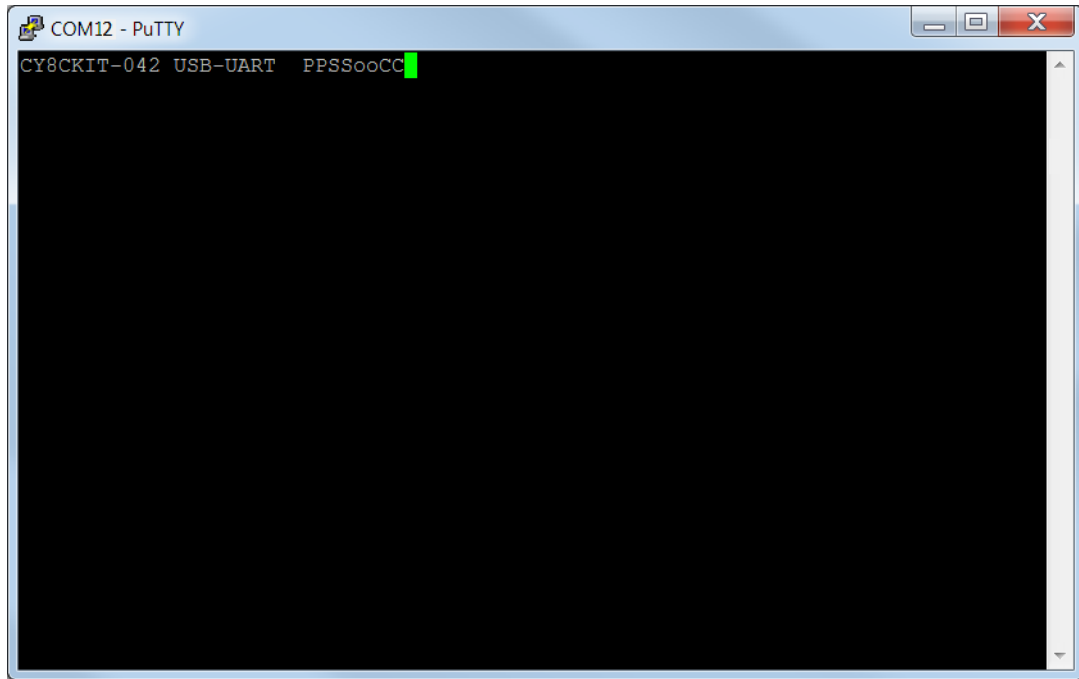

Figure 6-20. Data Displayed on PuTTY



6.2 Using PSoC 5LP as USB-I2C Bridge

The PSoC 5LP serves as a USB-I2C bridge, which can be used to communicate with the USB-I2C software running on the PC. This project is available with other code examples for the PSoC 4 Pioneer Kit at the element14 webpage, [100 Projects in 100 days](#).

The following steps describe how to use the USB-I2C bridge, which can communicate between the BCP and the PSoC 4.

1. Create a new CY8CKIT-042 (PSoC 4200) Kit project in PSoC Creator, as shown in the following figures. Select a specific location for your project and name the project as desired. You must select the appropriate target hardware (kit) for this project. Ensure that the **Select project template** option is set to 'Empty schematic'. This example uses PSoC 4200 as the target device and CY8CKIT-042 as the target board.

Figure 6-21. Select Project Type

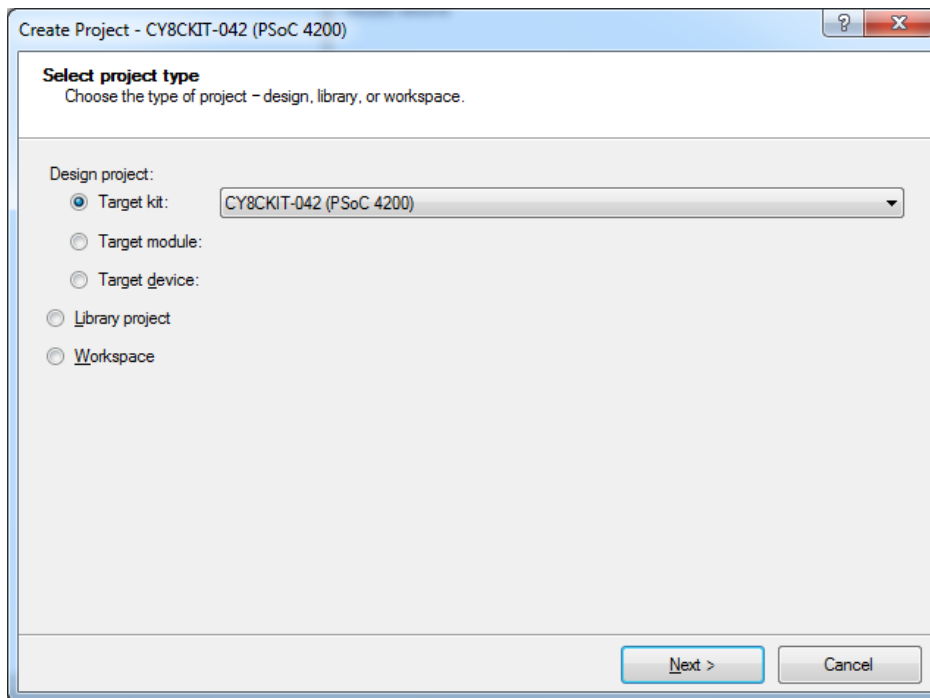

Figure 6-22. Select Empty Schematic Option

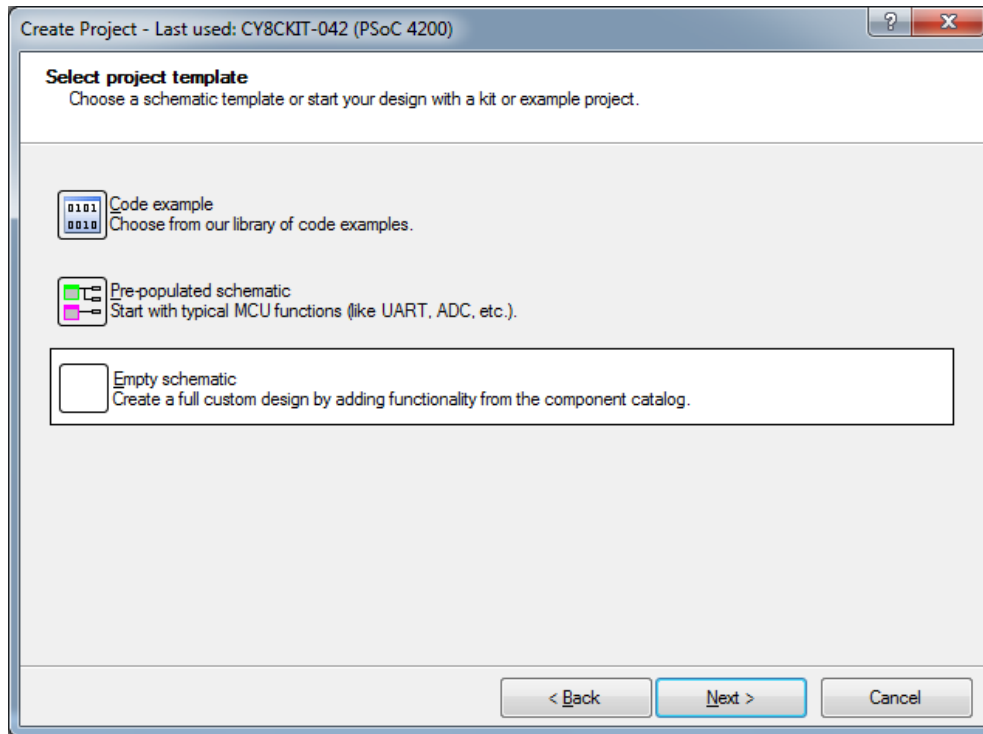
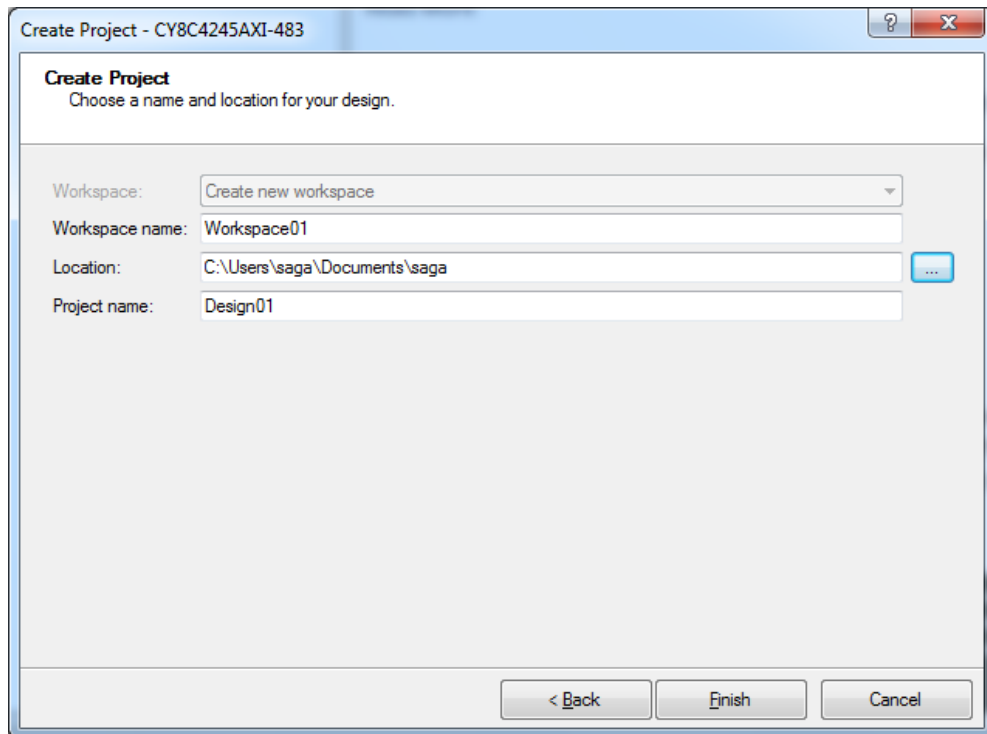
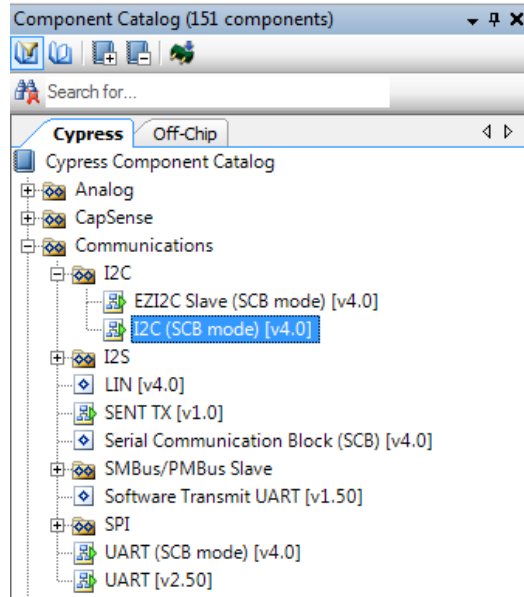

Figure 6-23. Create Project



2. Drag and drop an I2C component to the top design.

Figure 6-24. I2C Component in Component Catalog



3. To configure the I2C component, double-click or right-click on the I2C component and select **Configure**.

Figure 6-25. Open I2C Configuration Window

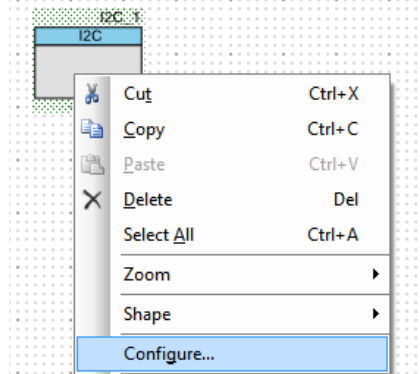

4. Change the component name from I2C_1 to I2C.
5. Configure the I2C with the following settings.

Figure 6-26. I2C Configuration Tab

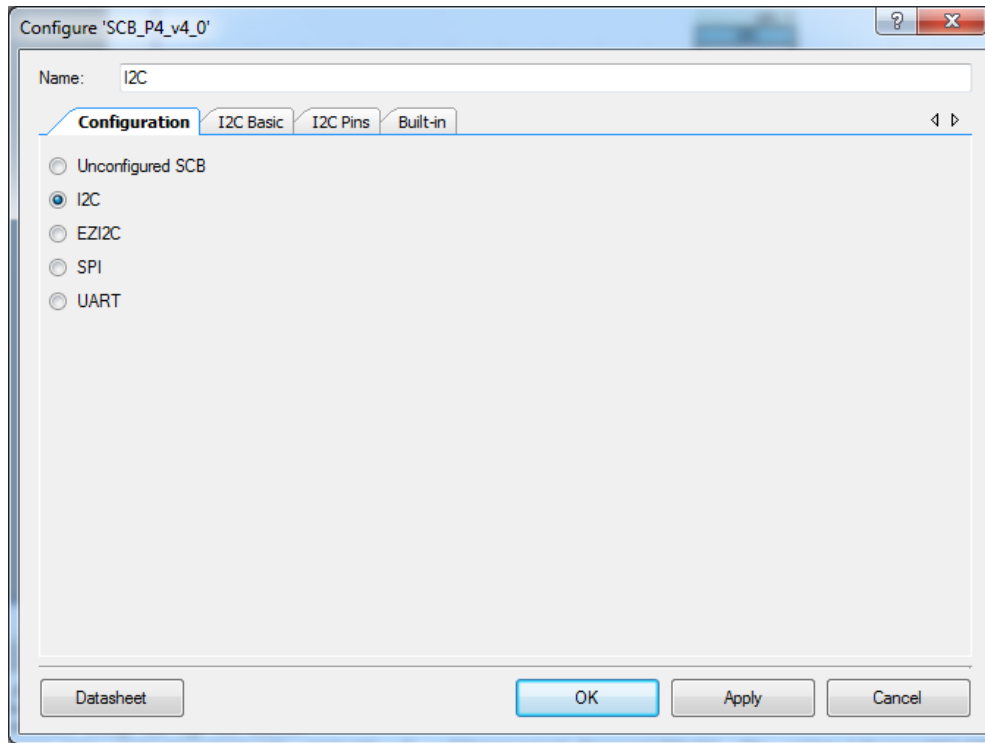

Figure 6-27. I2C Basic Tab

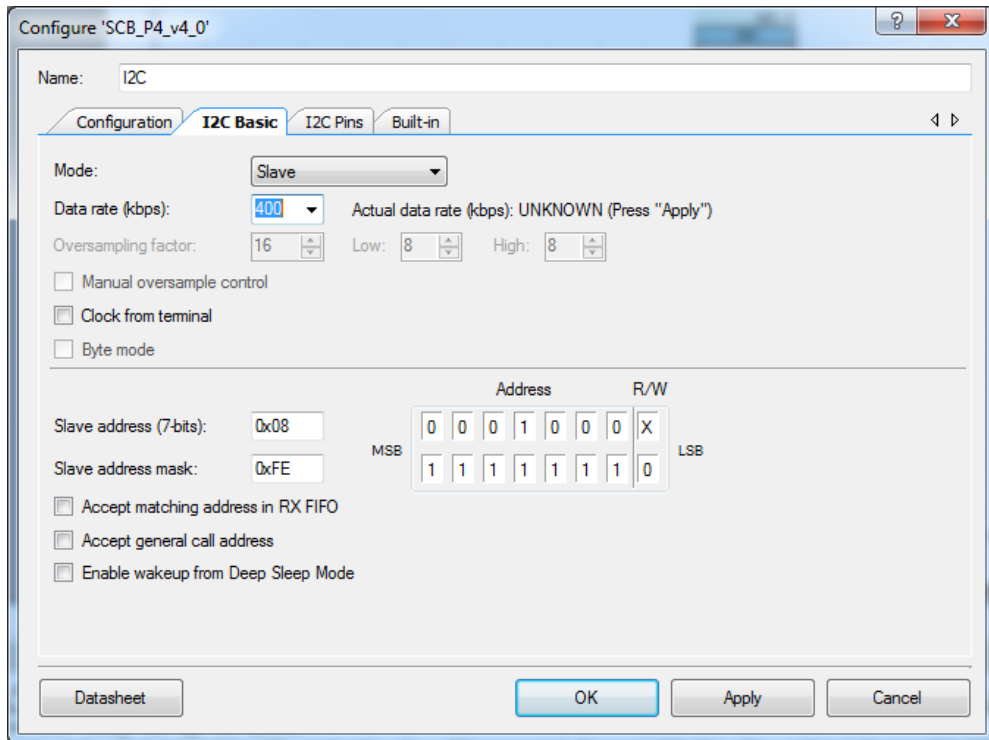
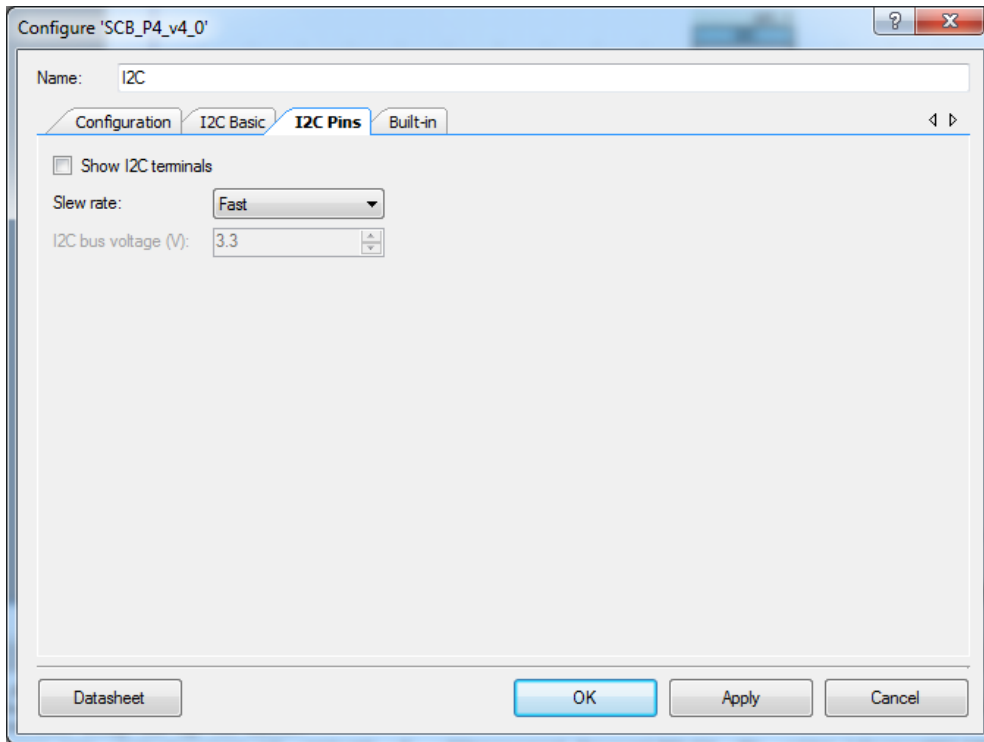

Figure 6-28. I2C Advanced Tab



6. Click **Apply** and then **OK** to save the changes.
7. Select pin **P3[0]** for the I2C SCL and pin **P3[1]** for the I2C SDA in the **Pins** tab of <project.cydwr>.

Figure 6-29. Pin Selection

	Name	Port	Pin	Lock
<input checked="" type="checkbox"/>	\I2C:scl\	P3[0]	11	<input checked="" type="checkbox"/>
<input checked="" type="checkbox"/>	\I2C:sda\	P3[1]	12	<input checked="" type="checkbox"/>

8. Place the following code in your *main.c* project file. The code will enable the PSoC 4 device to transmit and receive I2C data to and from the BCP application.

```

int main()
{

uint8 wrBuf[10]; /* I2C write buffer */
uint8 rdBuf[10]; /* I2C read buffer */
uint8 indexCntr;
uint32 byteCnt;

/* Enable the Global Interrupt */
CyGlobalIntEnable;

/* Start I2C Slave operation */
I2C_Start();

```

```

/* Initialize write buffer */
I2C_I2CSlaveInitWriteBuf((uint8 *) wrBuf, 10);
/* Initialize read buffer */
I2C_I2CSlaveInitReadBuf((uint8 *) rdBuf, 10);

for(;;) /* Loop forever */
{

/* Wait for I2C master to complete a write */
if(0u != (I2C_I2CSlaveStatus() & I2C_I2C_SSTAT_WR_CMPLT))
{

/* Read the number of bytes transferred */
byteCnt = I2C_I2CSlaveGetWriteBufSize();

/* Clear the write status bits*/
I2C_I2CSlaveClearWriteStatus();

/* Move the data written by the master to the read buffer so that the
master can read back the data */
for(indexCnt = 0; indexCnt < byteCnt; indexCnt++)
{
rdBuf [indexCnt] = wrBuf[indexCnt]; /* Loop back the data to the read
buffer */
}

/* Clear the write buffer pointer so that the next write operation will
start from index 0 */
I2C_I2CSlaveClearWriteBuf();

/* Clear the read buffer pointer so that the next read operations starts
from index 0 */
I2C_I2CSlaveClearReadBuf();
}
/* If the master has read the data , reset the read buffer pointer to 0
and clear the read status */
if(0u != (I2C_I2CSlaveStatus() & I2C_I2C_SSTAT_RD_CMPLT))
{
/* Clear the read buffer pointer so that the next read operations starts
from index 0 */
I2C_I2CSlaveClearReadBuf();

/* Clear the read status bits */
I2C_I2CSlaveClearReadStatus();
}
}
}

```

6. Build the project by clicking **Build > Build Project** or **[Shift]+[F6]**. After the project is built without errors and warnings, program (**[Ctrl]+[F5]**) this code onto the PSoC 4 through the PSoC 5LP programmer or MiniProg3.
7. Open the BCP from **Start > All Programs > Cypress > Bridge Control Panel <version number>**.
8. Connect to **KitProg/<serial_number>** under **Connected I2C/SPI/RX8 Ports**.

Figure 6-30. Connecting to KitProg/<serial_number> in BCP

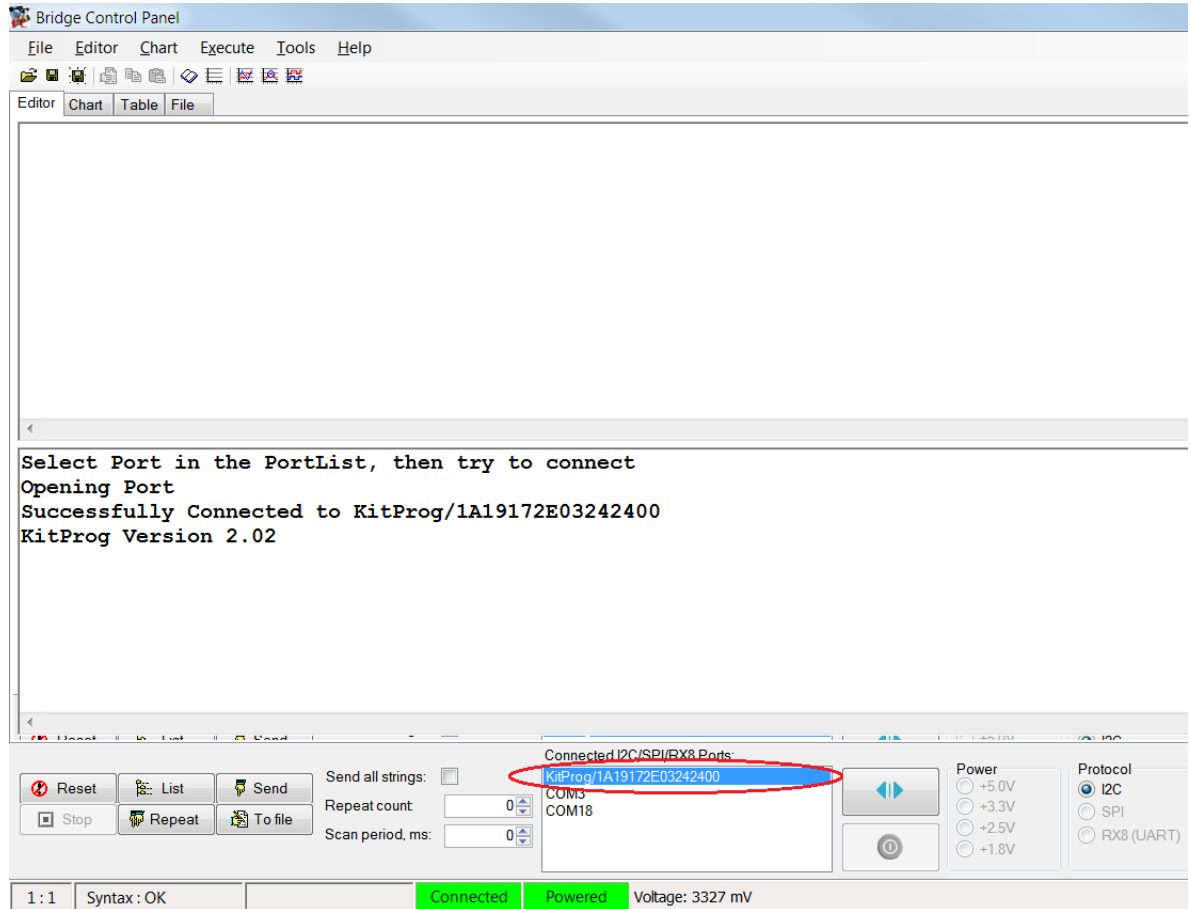

9. Open **Protocol Configuration** from the **Tools** menu and select the appropriate **I2C Speed**. Make sure the I2C speed is the same as the one configured in the I2C component. Click **OK** to close the window.

Figure 6-31. Opening Protocol Configuration Window in BCP

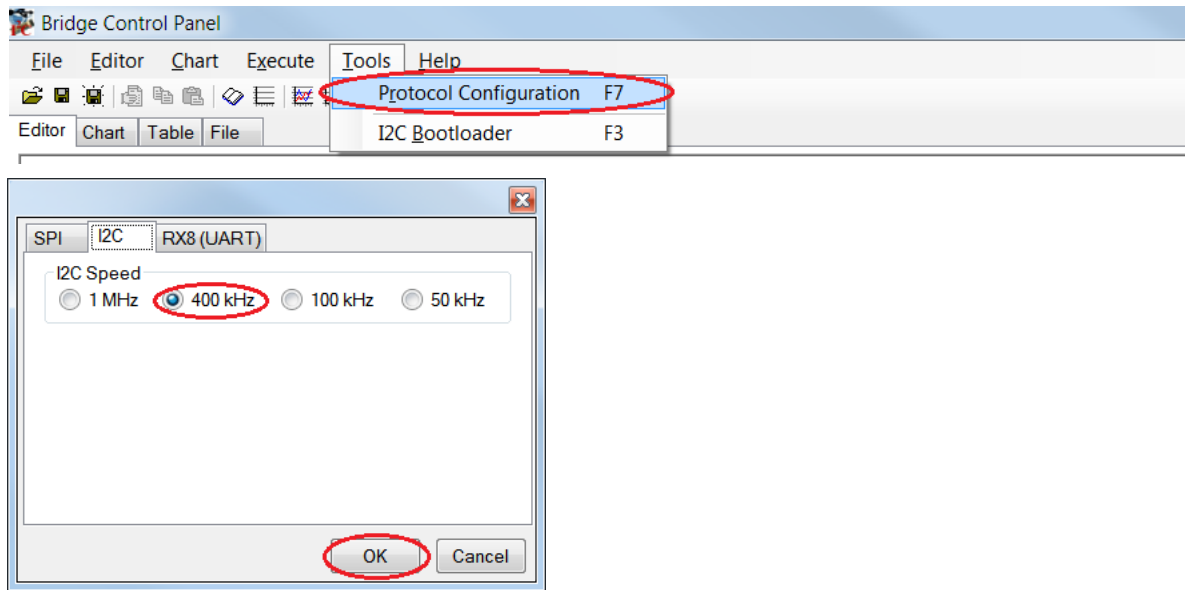

10. From the BCP, transfer five bytes of data to the I2C device with slave address 0x08. The log shows whether the transaction was successful. A '+' indication after each byte indicates that the transaction was successful and a '-' indicates that the transaction was a failure.

Figure 6-32. Entering Commands in BCP

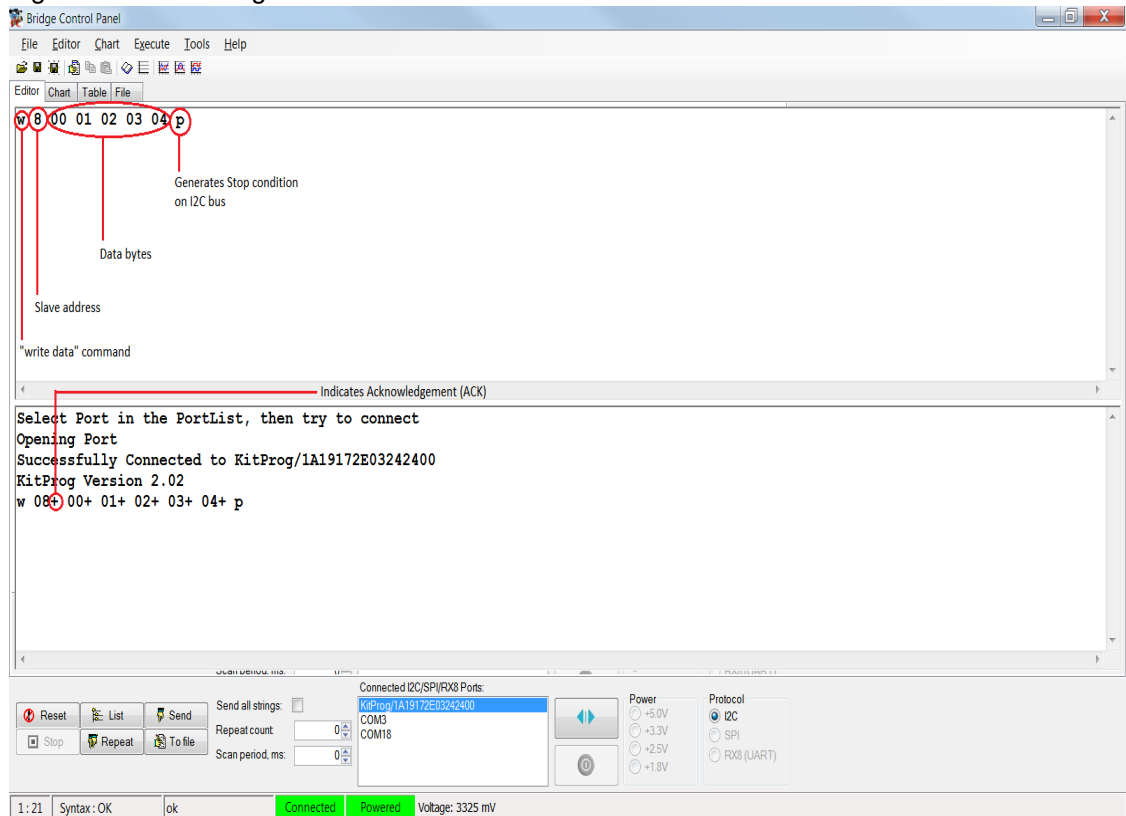
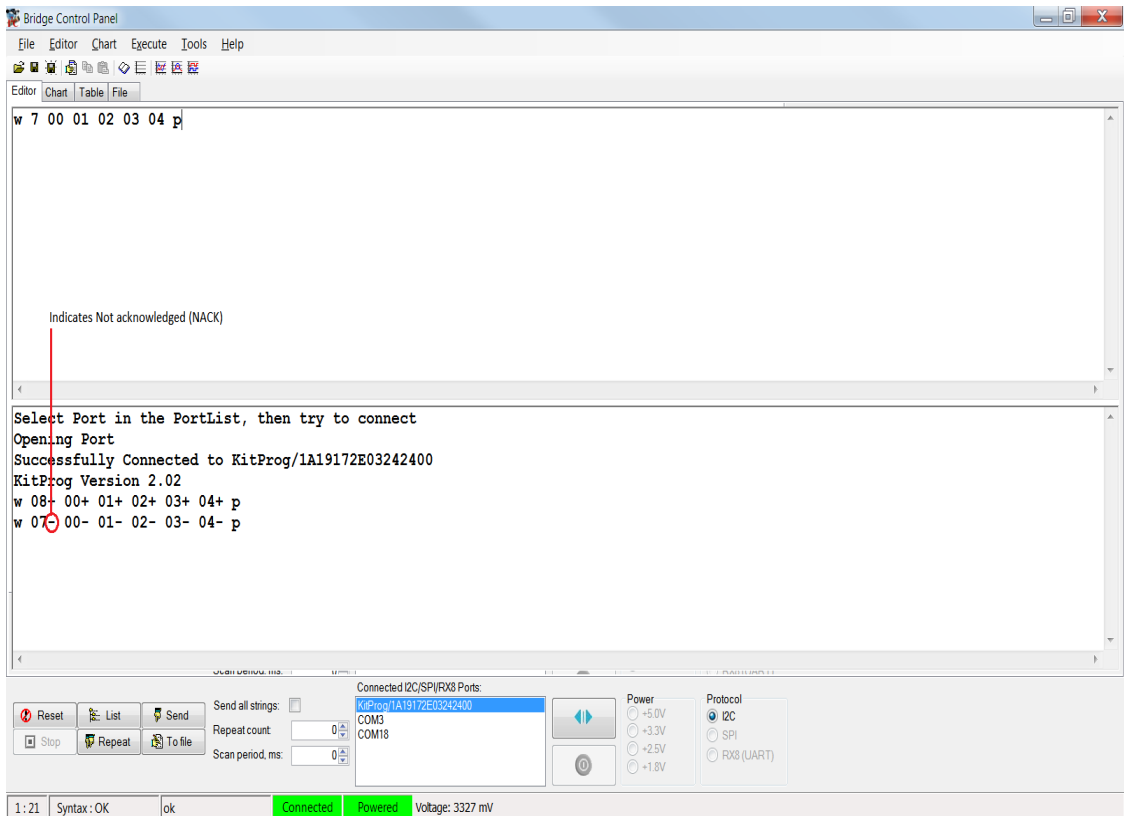
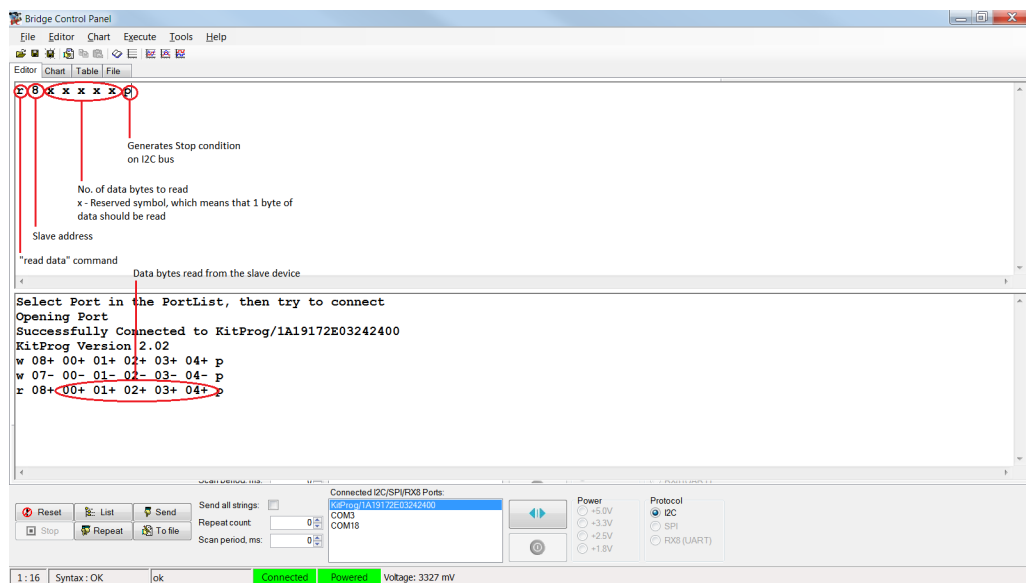

Figure 6-33. NACK Indication in BCP



11. From the BCP, read five bytes of data from the I2C slave device with slave address 0x08. The log shows whether the transaction was successful.

Figure 6-34. Read Data Bytes from the BCP



Note: Refer **Help Contents** under **Help** in BCP or press **[F1]** for details of I2C commands.

6.3 Developing Applications for PSoC 5LP

The PSoC 4 Pioneer Kit has an onboard PSoC 5LP whose primary function is that of a programmer and a bridge. You can build either a normal project or a bootloadable project using the PSoC 5LP.

The PSoC 5LP connections in the Pioneer board are summarized in [Figure 6-35](#). J8 is the I/O connector (see section [PSoC 5LP GPIO Header \(J8\) on page 39](#)). The USB (J10) is connected and used as the PC interface. But you can still use this USB connection to create customized USB designs.

The programming header (J7) is meant for standalone programming. This header needs to be populated. See the 'No Load Components' section in [Bill of Materials \(BOM\) on page 116](#).

Figure 6-35. PSoC 5LP Block Diagram

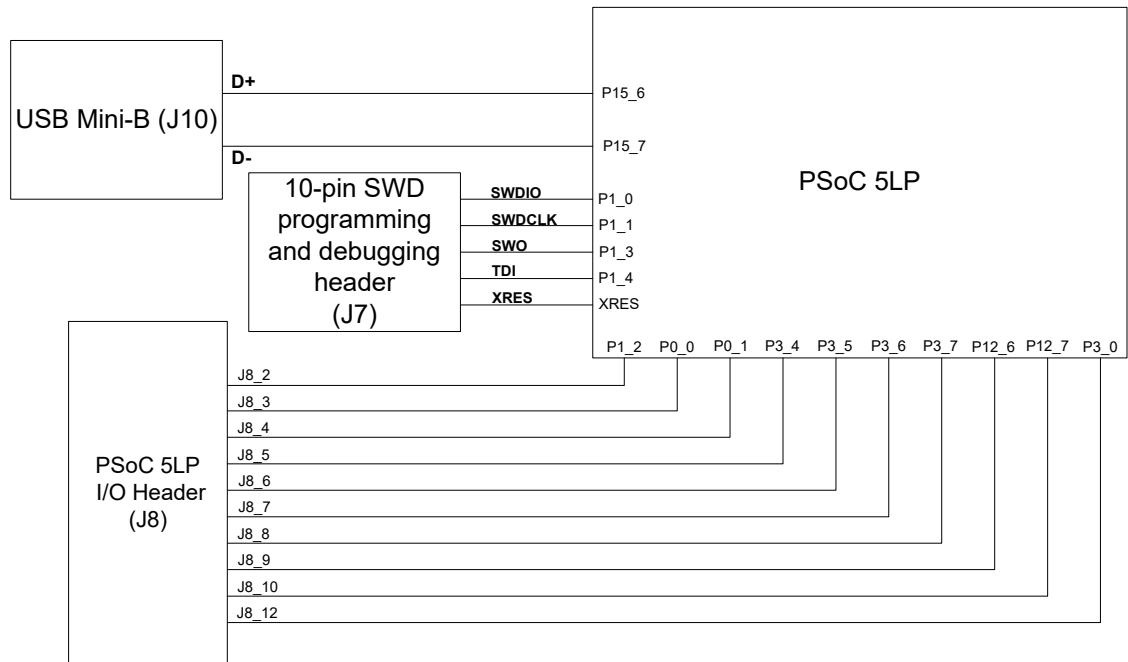

6.3.1 Building a Bootloadable Project for PSoC 5LP

All bootloadable applications developed for the PSoC 5LP should be based on the bootloader hex file, which is programmed onto the kit. The bootloader hex file is available in the kit files or can be downloaded from the [kit webpage](#).

The hex files are included in the following kit installer directory:

```
<Install_Directory>\CY8CKIT-042 PSoC 4 Pioneer Kit\  
<version>\Firmware\Programmer\KitProg_Bootloader
```

Figure 6-36. KitProg Bootloader Hex File Location

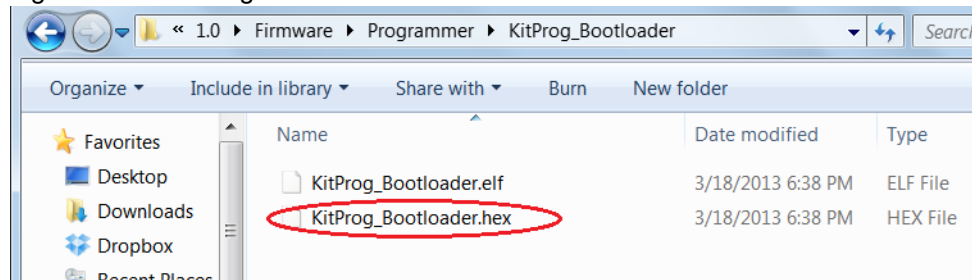

To build a bootloadable application for the PSoC 5LP, follow this procedure:

1. In PSoC Creator, choose **File > New > Project** and select **Target Device**; select **<Launch Device Selector...>** from the drop-down list, as shown in [Figure 6-37](#).

Figure 6-37. Opening New Project in PSoC Creator

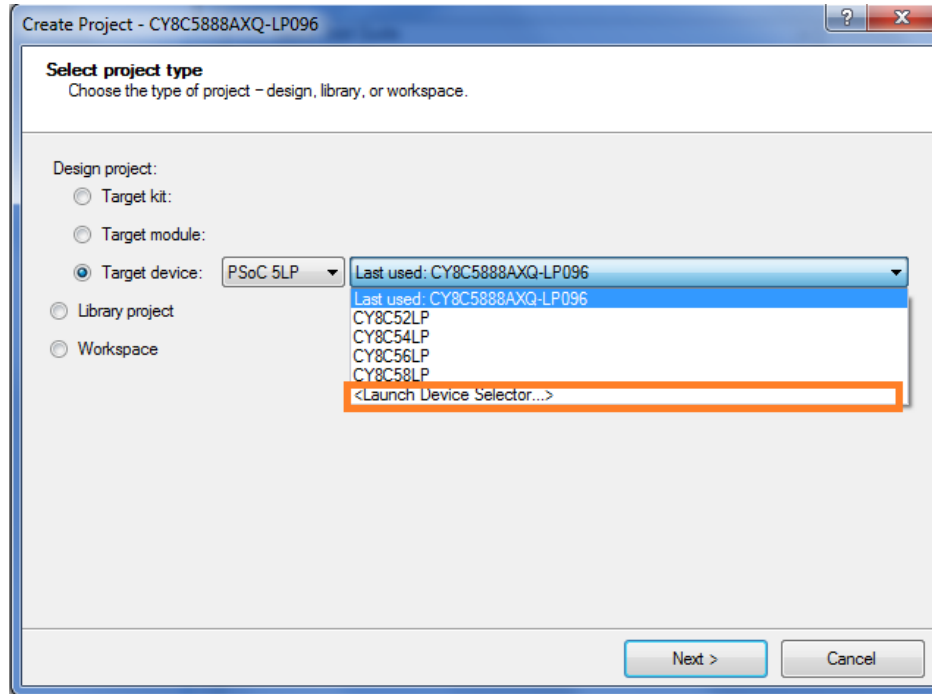

2. Select **CY8C5868LTI-LP039**, as shown in [Figure 6-38](#). Click **OK**; then, click **Next**.

Figure 6-38. Selecting Device in PSoC Creator

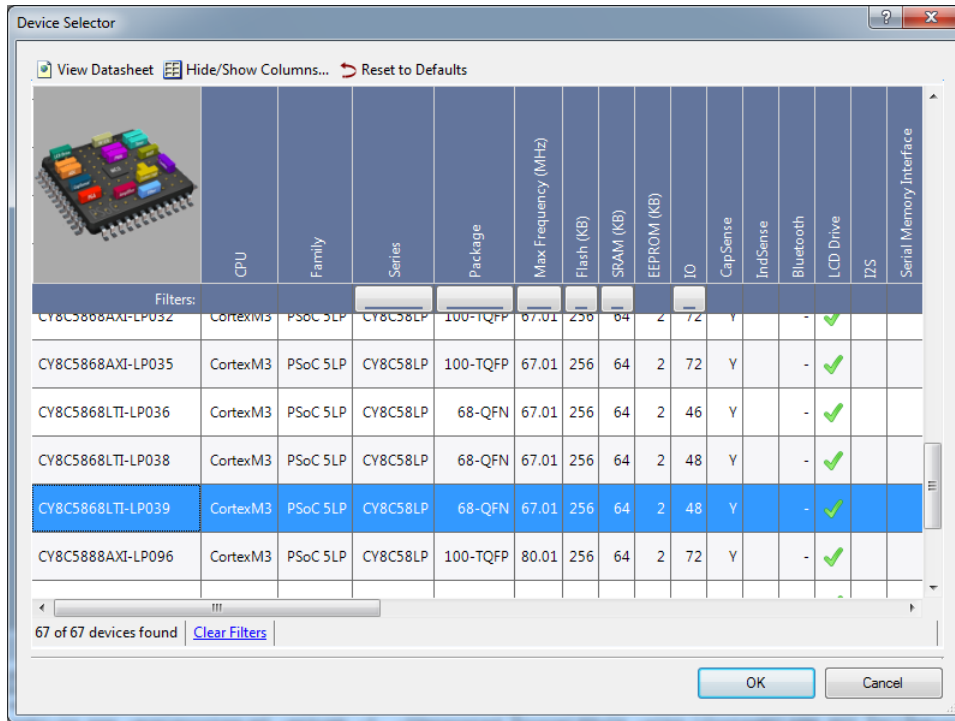

3. Choose **Empty schematic** in the **Select project template** dialog, as shown in Figure 6-39. Click **Next**.

Figure 6-39. Choose Empty Schematic

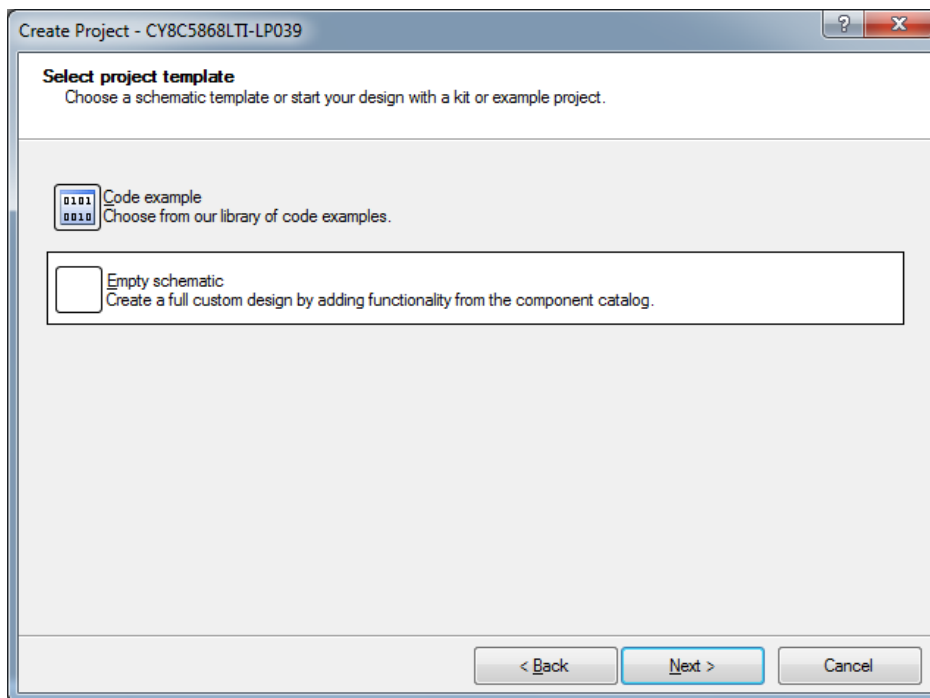

4. In the Create Project dialog, choose the workspace name, location, and project name (Figure 6-40). Click **Finish**.

Figure 6-40. Create Project Dialog

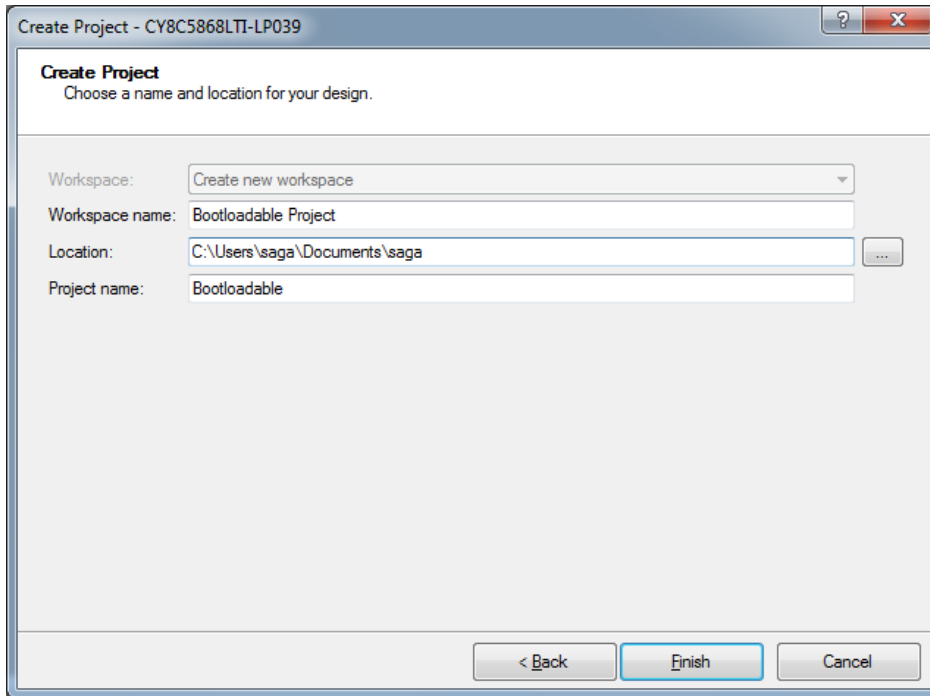

5. Navigate to the Schematic view and drag and drop a bootloadable component on the top design.

Figure 6-41. Bootloadable Component in Component Catalog

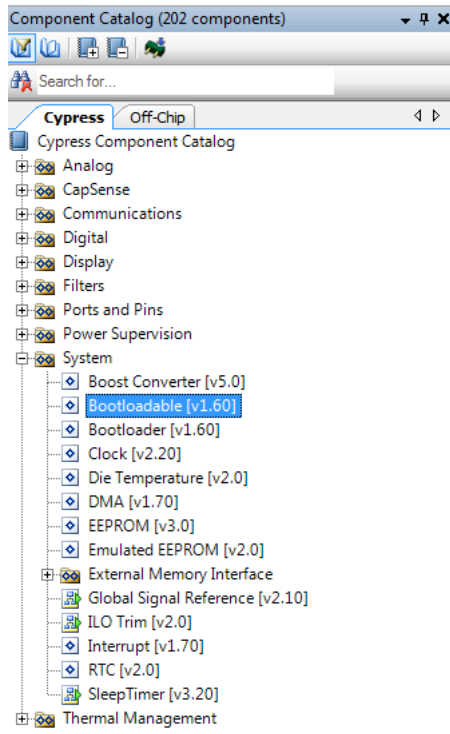

Set the dependency of the Bootloadable component by selecting the **Dependencies** tab in the configuration window and clicking the **Browse** button. Select the *KitProg_Bootloader.hex* and *KitProg_Bootloader.elf* files; click **Open**.

Figure 6-42. Configuration Window of Bootloadable Component

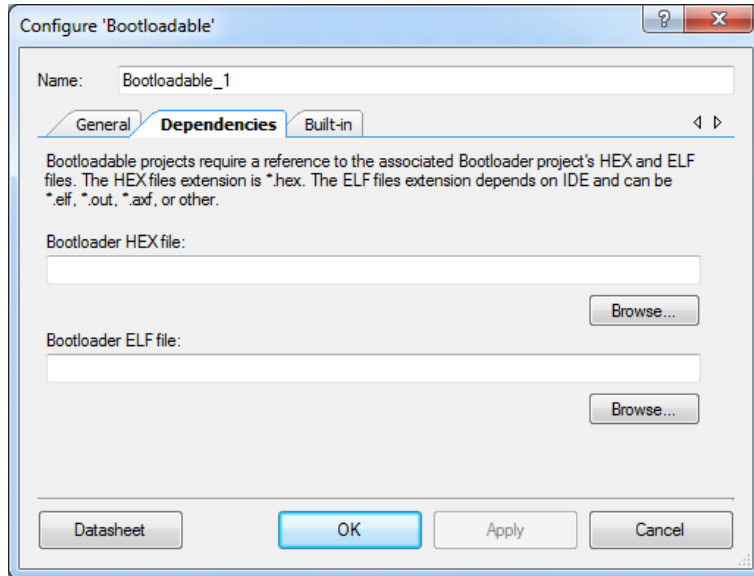

Figure 6-43. Selecting KitProg Bootloader Hex File

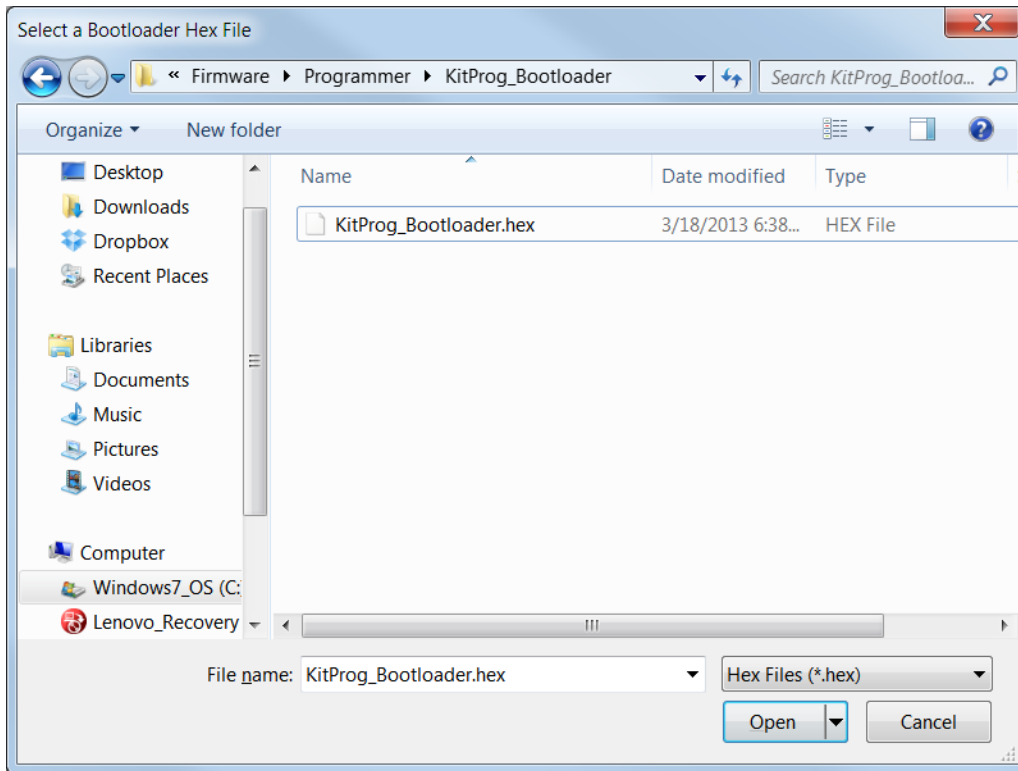
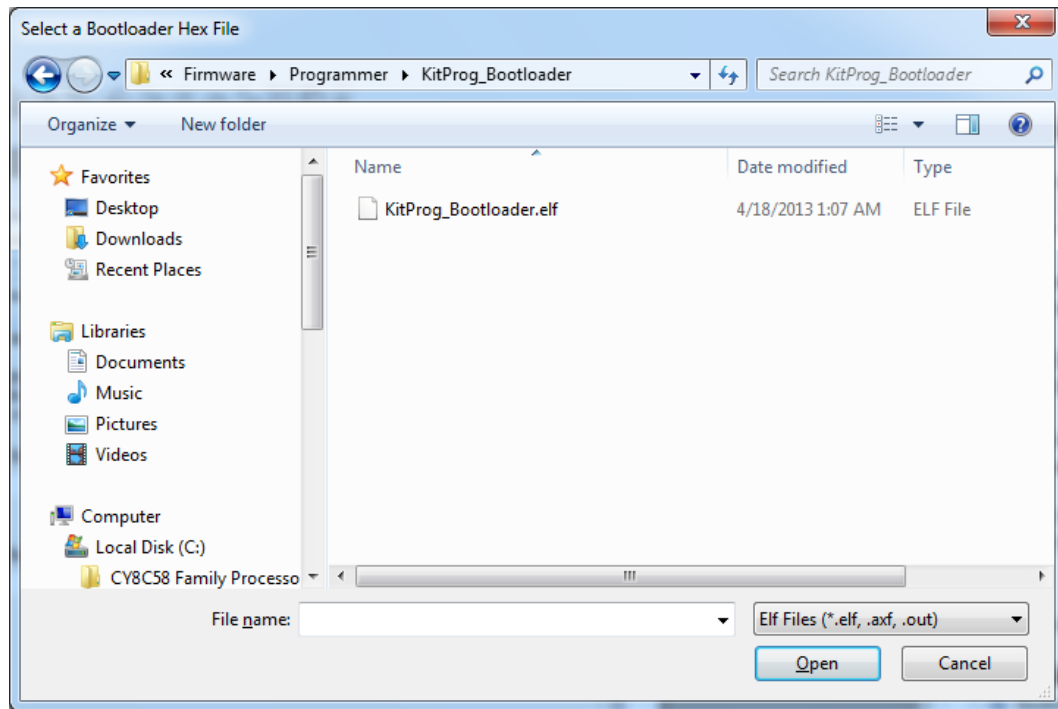
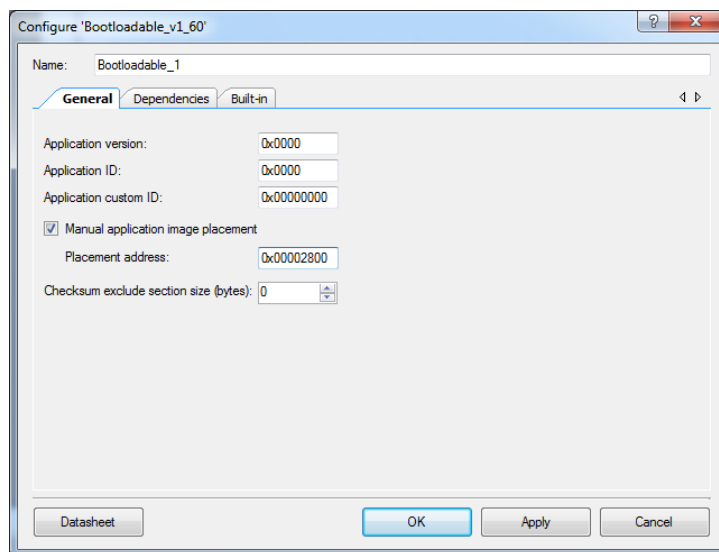

Figure 6-44. Selecting KitProg Bootloader File



3. In the **General** tab, check the **Manual application image placement** checkbox and set the **Placement address** as “0x00002800” as shown in Figure 6-45.

Figure 6-45. Bootloadable Component-General Tab



4. Develop your custom project.
5. The NVL setting of the Bootloadable project and the KitProg_Bootloader project must be the same. The *KitProg_Bootloader.cydwr* system settings is shown in the following figure.

Figure 6-46. KitProg Bootloader System Settings

Option	Value
Configuration	
Device Configuration Mode	Compressed
Enable Error Correcting Code (ECC)	<input type="checkbox"/>
Store Configuration Data in ECC Memory	<input type="checkbox"/>
Instruction Cache Enabled	<input checked="" type="checkbox"/>
Enable Fast IMO During Startup	<input checked="" type="checkbox"/>
Unused Bonded IO	Allow with info
Heap Size (bytes)	0x1000
Stack Size (bytes)	0x4000
Include CMSIS Core Peripheral Library Files	<input checked="" type="checkbox"/>
Programming/Debugging	
Debug Select	GPIO
Enable Device Protection	<input type="checkbox"/>
Embedded Trace (ETM)	<input type="checkbox"/>
Use Optional XRES	<input type="checkbox"/>
Operating Conditions	
VDDA (V)	5.0
Variable VDDA	<input type="checkbox"/>
VDDD (V)	5.0
VDDIO0 (V)	5.0
VDDIO1 (V)	5.0
VDDIO2 (V)	5.0
VDDIO3 (V)	5.0
Temperature Range	-40C - 85/125C

Sets the Port 1 preferred program/debug interface (JTAG or SWD or SWD+SWV) that the chip enables by default for use after power up or reset. Setting to GPIO frees the pins for use as GPIOs but does not completely disable the debug interface for flash protection purposes. *Enable Device Protection is set for this purpose. For more information about programming and debugging options see the device data sheet or Technical Reference Manual (TRM).

- Build the project in PSoC Creator by selecting **Build > Build Project** or **[Shift]+[F6]**.
- To download the project on to the PSoC 5LP device, open the Bootloader Host Tool, which is available from PSoC Creator. Select **Tools > Bootloader Host**.

Figure 6-47. Opening Bootloader Host Tool from PSoC Creator

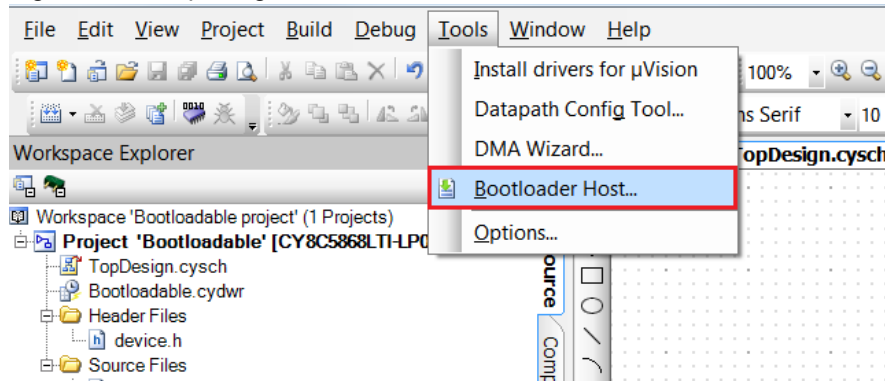

- Keep the reset switch (SW1) pressed and plug in the USB Mini-B connector. If the switch is pressed for more than 100 ms, the PSoC 5LP enters into bootloader. The PSoC 5LP also enters into bootloader when the power supply jumper for the PSoC 4 (J13) is removed and subsequently the USB Mini-B connector is plugged into header J10.

- In the Bootloader Host tool, click **Filters** and add a filter to identify the USB device. Set VID as **0x04B4**, PID as **0xF13B**, and click **OK**.

Figure 6-48. Port Filters Tab in Bootloader Host Tool

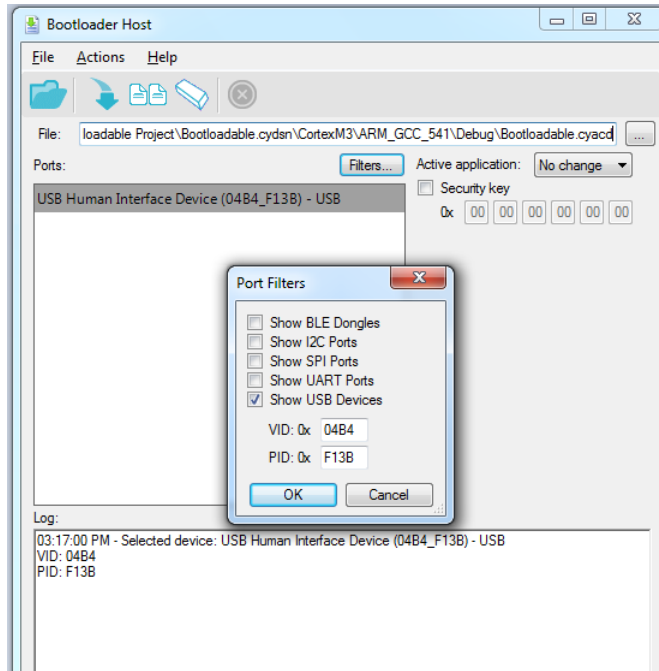

- In the Bootloader Host tool, click the **Open File** button to browse to the location of the bootloadable file (*.cyacd).

Figure 6-49. Opening Bootloadable File from Bootloader Host Tool

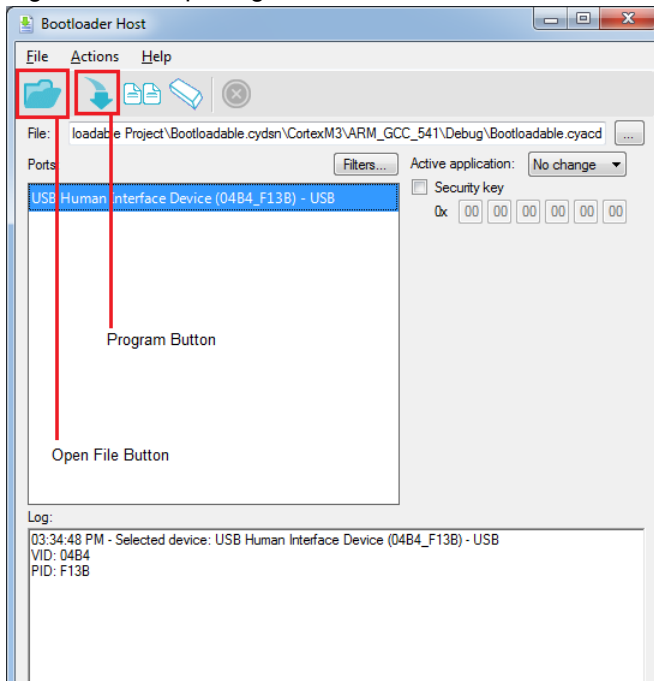

11. Press the **Program** button in the Bootloader Host tool to program the device.

Figure 6-50. Selecting *Bootloadable.cyacd* File from Bootloader Host

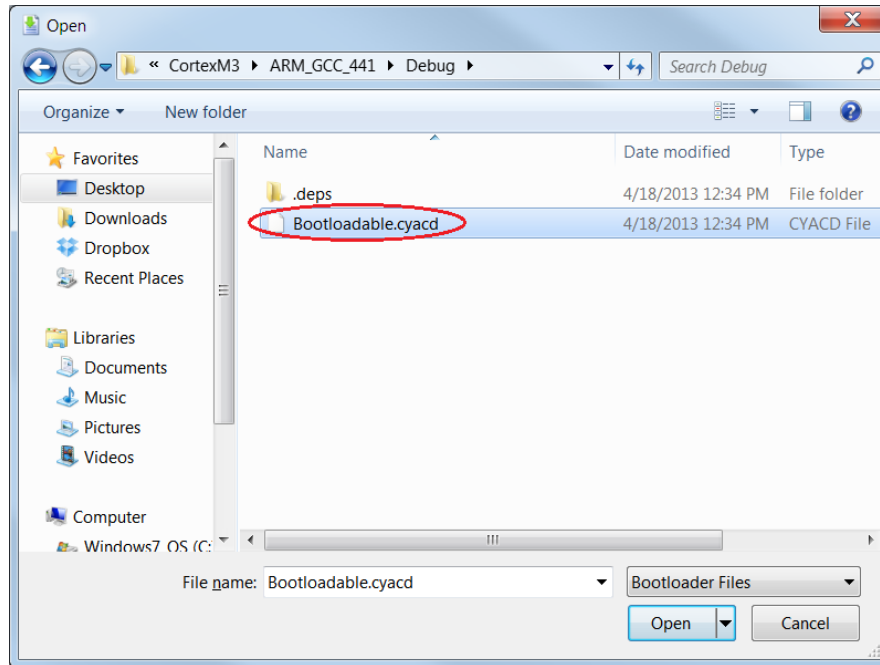

12. If bootload is successful, the log of the tool displays "Successful"; otherwise, it displays "Failed" and a statement for the failure.

Notes:

1. The PSoC 5LP pins are brought to the PSoC 5LP GPIO header (J8). These pins are selected to support high-performance analog and digital projects. See [Pin Assignment Table on page 111](#) for pin information.
2. Take care when allocating the PSoC 5LP pins for custom applications. For example, P2[0]–P2[4] are dedicated for programming the PSoC 4. Refer to [CY8CKIT-042 Schematics on page 107](#) before allocating the pins.
3. When a normal project is programmed onto the PSoC 5LP, the initial capability of the PSoC 5LP to act as a programmer, USB-UART bridge, or USB-I2C bridge is not available.
4. The status LED does not function unless used by the custom project.

For additional information on bootloaders, refer to Cypress application note, [AN73503 - PSoC[®] USB HID Bootloader](#).

6.3.2 Building a Normal Project for PSoC 5LP

A normal project is a completely new project created for the PSoC 5LP device on the CY8CKIT-042. Here the entire flash of the PSoC 5LP is programmed, overwriting all bootloader and programming code. To recover the programmer, reprogram the PSoC 5LP device with the factory-set *KitProg.hex* file, which is shipped with the kit installer.

The *KitProg.hex* file is available at the following location:

```
<Install_Directory>\CY8CKIT-042 PSoC 4 Pioneer Kit\<version>\Firm-
ware\Programmer\KitProg
```

This advanced functionality requires a MiniProg3 programmer, which is not included with this kit. The MiniProg3 can be purchased from www.cypress.com/CY8CKIT-002.

To build a normal project for the PSoC 5LP, follow these steps:

1. In PSoC Creator, choose **File > New > Project** and select **Target device**; select **<Launch Device Selector...>** from the drop-down list as shown in [Figure 6-51](#).

Figure 6-51. Opening New Project in PSoC Creator

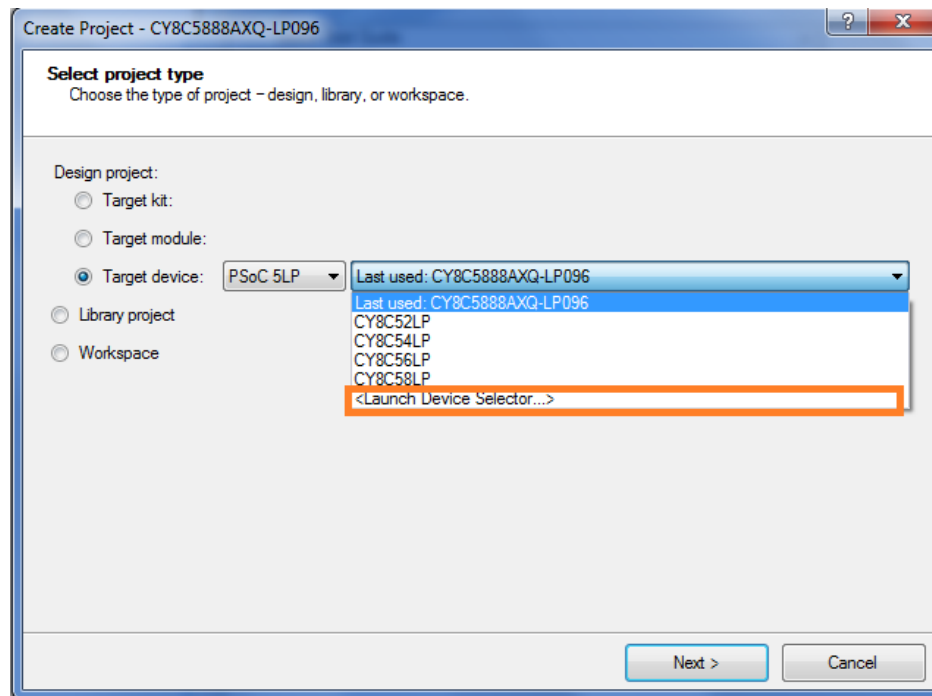

2. Select **CY8C5868LTI-LP039**, as shown in [Figure 6-52](#). Click **OK** and click **Next**.

Figure 6-52. Select Device

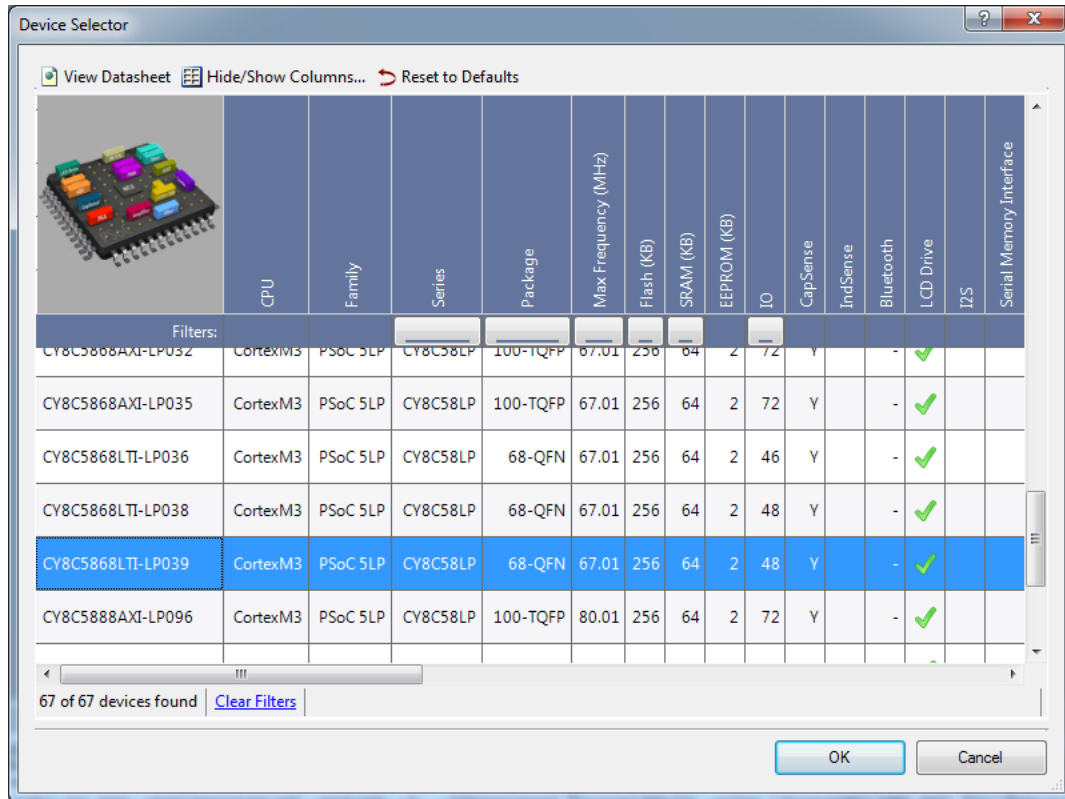

3. Choose **Empty schematic** in the **Select project template** dialog, as shown in Figure 6-53. Click **Next**.

Figure 6-53. Choose Empty Schematic

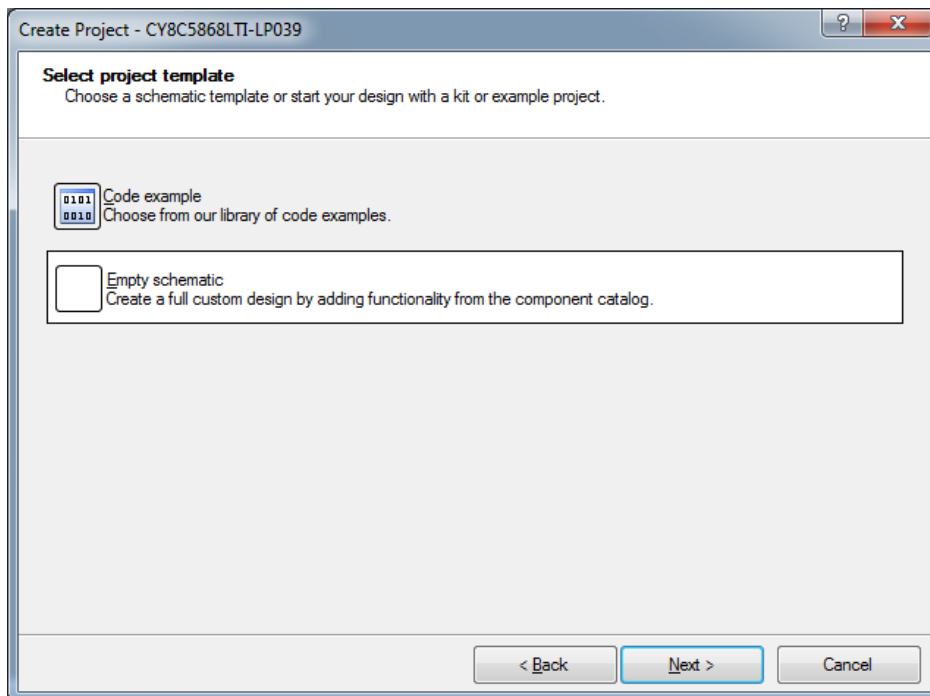

- In the Create Project dialog, choose the workspace name, location, and project name (Figure 6-54). Click **Finish**.

Figure 6-54. Create Project Dialog

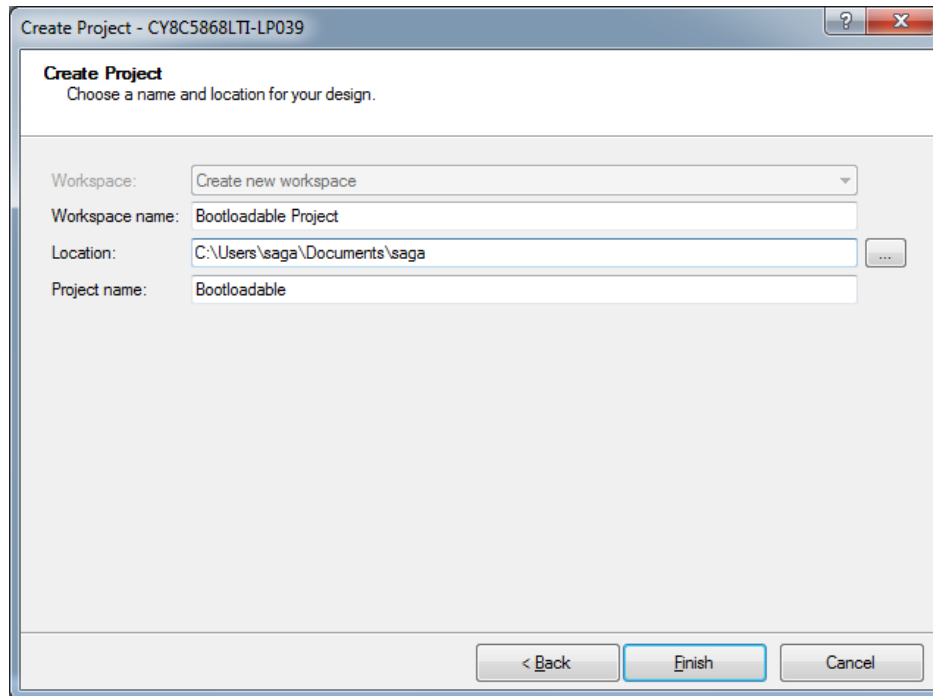

- Develop your custom project.
- Build the project in PSoC Creator by selecting **Build > Build Project** or **[Shift]+[F6]**.
- Connect the 10-pin connector of MiniProg3 to the onboard 10-pin SWD debug and programming header J7 (which needs to be populated).
- To program the PSoC 5LP with PSoC Creator, click **Debug > Program** or **[Ctrl]+[F5]**. The Programming window shows MiniProg3 and the selected device in the project under it (CY8C5868LTI-LP039).
- Click on the device and click **Connect** to program.

Notes:

- The 10-pin SWD debug and programming header (J7) is not populated. See the 'No Load Components' section of [Bill of Materials \(BOM\) on page 116](#) for details.
- The PSoC 5LP pins are brought to the PSoC 5LP GPIO header (J8). These pins are selected to support high-performance analog and digital projects. See [Pin Assignment Table on page 111](#) for pin information.
- Take care when allocating the PSoC 5LP pins for custom applications. For example, P2[0]–P2[4] are dedicated for programming the PSoC 4. Refer to [CY8CKIT-042 Schematics on page 107](#) before allocating the pins.
- When a normal project is programmed onto the PSoC 5LP, the initial capability of the PSoC 5LP to act as a programmer, USB-UART bridge, or USB-I2C bridge is not available.
- The status LED does not function unless used by the custom project.

6.4 PSoC 5LP Factory Program Restore Instructions

The CY8CKIT-042 PSoC 4 Pioneer Kit features a PSoC 5LP device that comes factory-programmed as the onboard programmer and debugger for the PSoC 4 device.

In addition to creating applications for the PSoC 4 device, you can also create custom applications for the PSoC 5LP device on this kit. For details, see section [Developing Applications for PSoC 5LP on page 87](#). Reprogramming or bootloading the PSoC 5LP device with a new flash image will overwrite the factory program and forfeit the ability to use the PSoC 5LP device as a programmer/debugger for the PSoC 4 device. Follow the instructions to restore the factory program on the PSoC 5LP and enable the programmer/debugger functionality.

6.4.1 PSoC 5LP is Programmed with a Bootloadable Application

If the PSoC 5LP is programmed with a bootloadable application, restore the factory program by using one of the following two methods.

6.4.1.1 *Restore PSoC 5LP Factory Program Using PSoC Programmer*

1. Launch PSoC Programmer from **Start > Cypress > PSoC Programmer <version>**.
2. Configure the PSoC 4 Pioneer Kit in Bootloader mode. To do this, while holding down the reset button (SW1 Reset), plug in the PSoC 4 Pioneer Kit to the computer using the included USB cable (USB A to mini-B). This puts the PSoC 5LP into service mode, which is indicated by the blinking green status LED.

- The following message appears in the PSoC Programmer results window: “KitProg Bootloader device is detected”.

Figure 6-55. PSoC Programmer Results Window

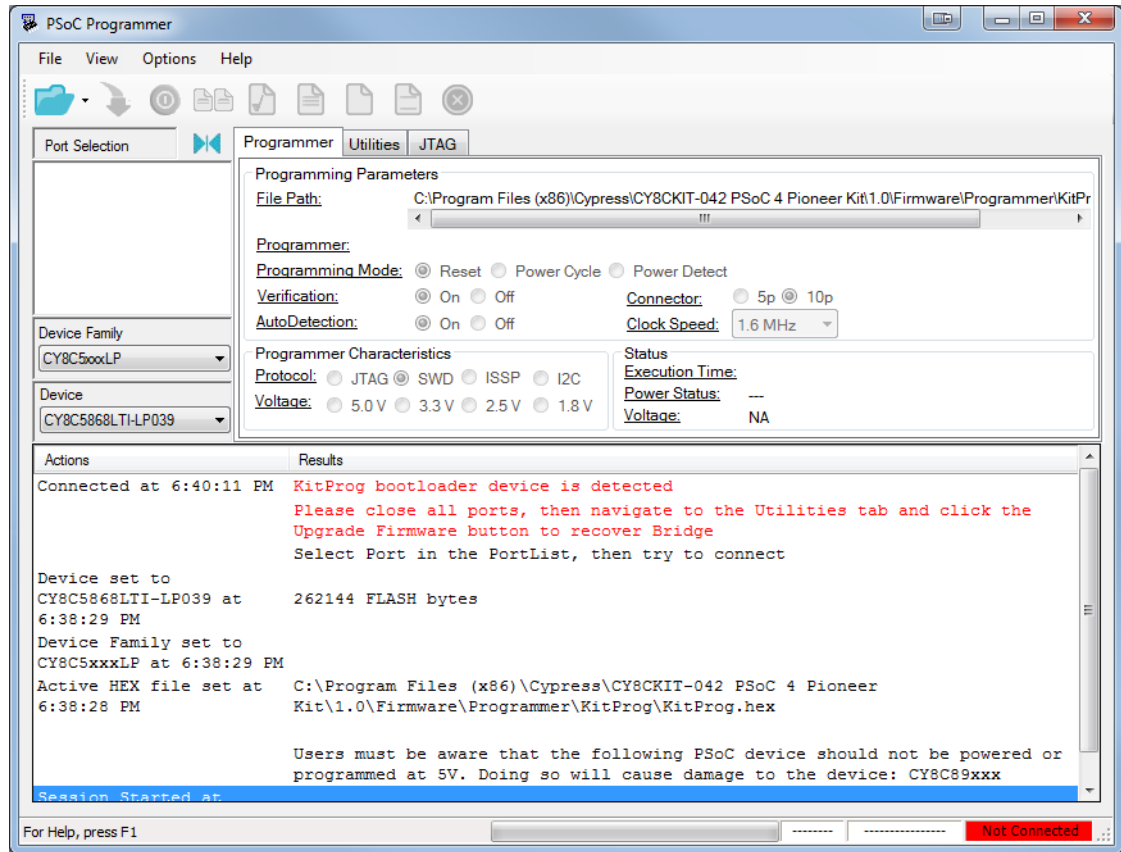

- Switch to the **Utilities** tab in PSoC Programmer and press the **Upgrade Firmware** button. Unplug all other PSoC programmers (such as MiniProg3 and DVKProg) from the PC before pressing the **Upgrade Firmware** button.

Figure 6-56. Upgrade Firmware

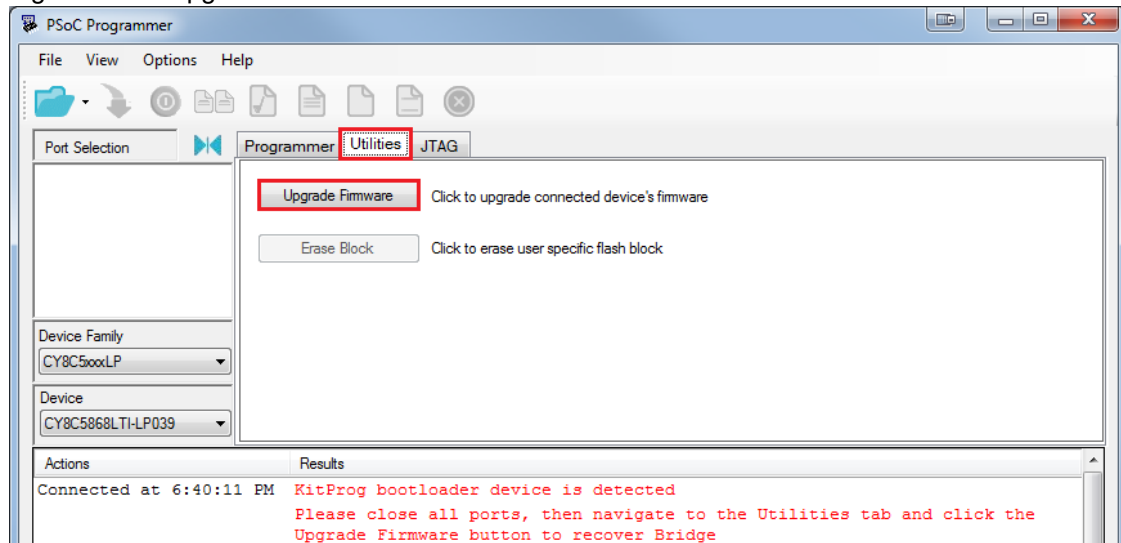

- After programming has completed, the following message appears: “Firmware Update Finished at <time>”.

Figure 6-57. Firmware Update Complete

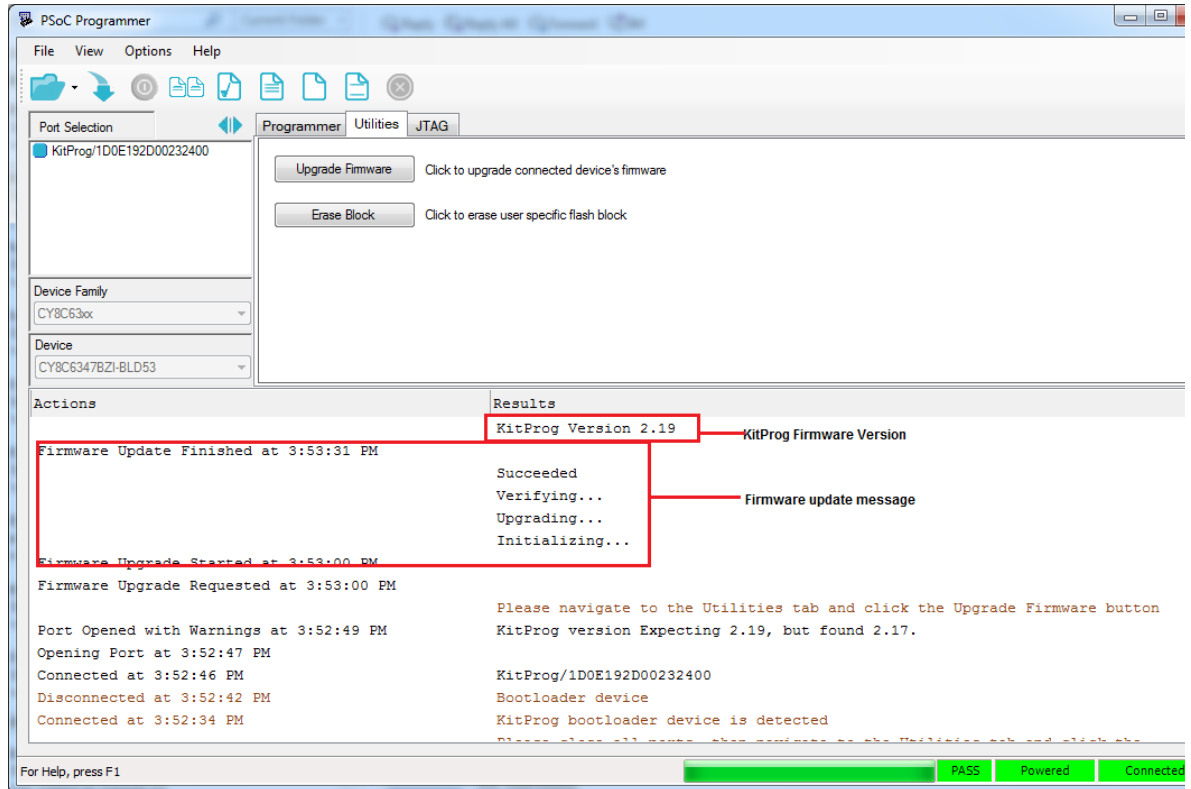

- The factory program is now successfully restored on the PSoC 5LP. It can be used as the programmer/debugger for the PSoC 4 device.

6.4.1.2 Restore PSoC 5LP Factory Program Using Bootloader Host Tool

1. Launch the Bootloader Host tool from **Start > Cypress > PSoC Creator**.
2. Using the **File > Open** menu, load the *Kit Prog.cyacd* file, which is installed with the kit software. The default location for this file is: <Install_Directory>\CY8CKIT-042 PSoC 4 Pioneer Kit\<version>\Firmware\Programmer\KitProg\KitProg.cyacd

Figure 6-58. Load KitProg.cyacd File

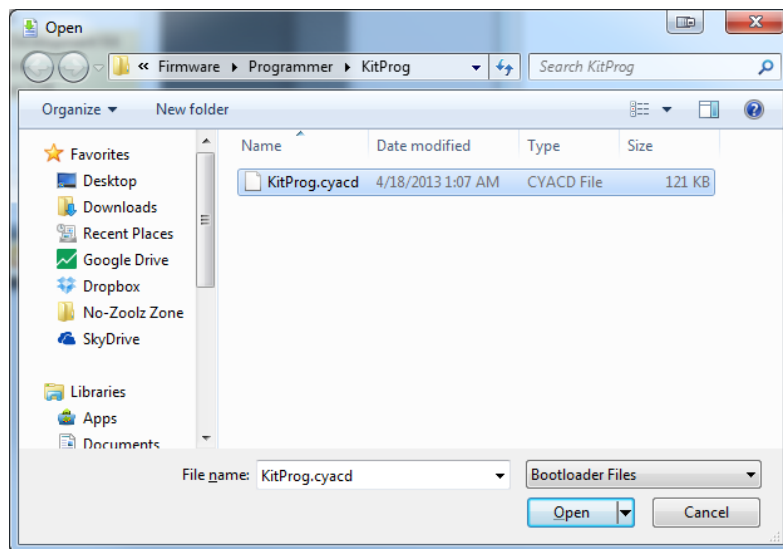
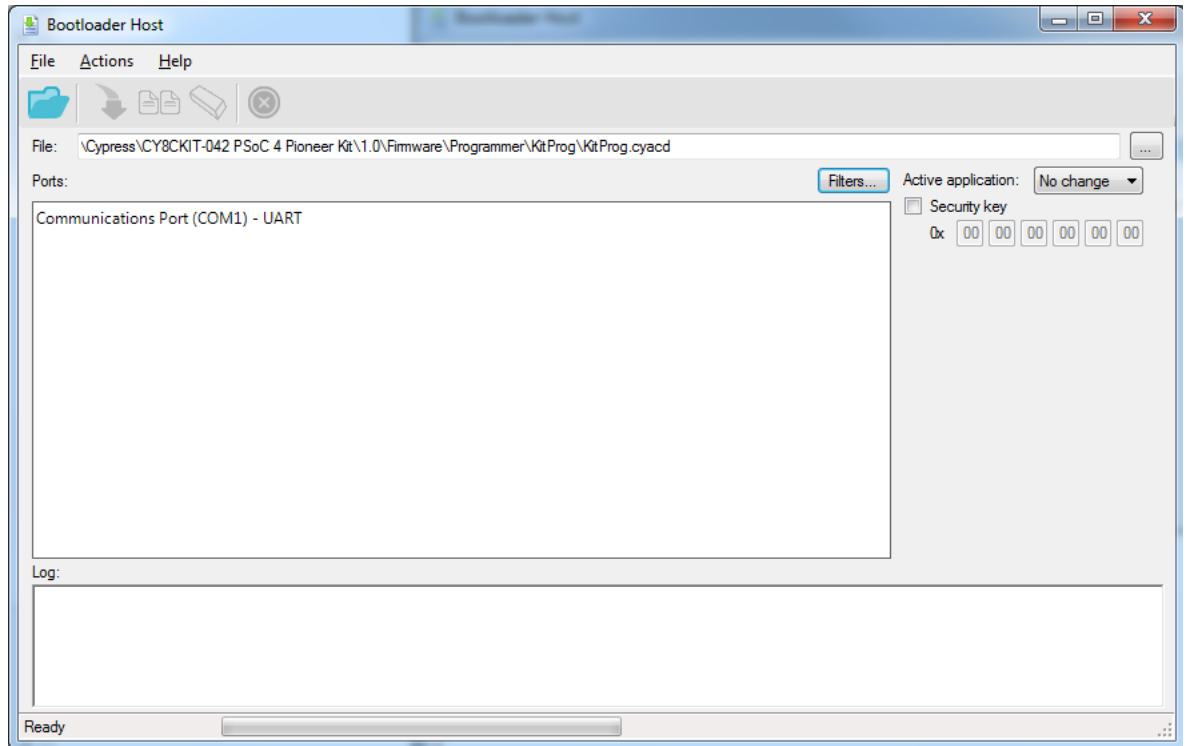

3. Configure the PSoC 4 Pioneer Kit in Service Mode. To do this, while holding down the reset button (SW1 Reset), plug in the PSoC 4 Pioneer Kit to the computer using the included USB cable (USB A to mini-B). This puts the PSoC 5LP into service mode, which is indicated by the blinking green status LED.
4. In the Bootloader Host tool, set the filters for the USB devices with VID: 04B4 and PID: F13B. **USB Human Interface Device** port appears in the Ports list. Click that port to select it.

Figure 6-59. Select USB Human Interface Device

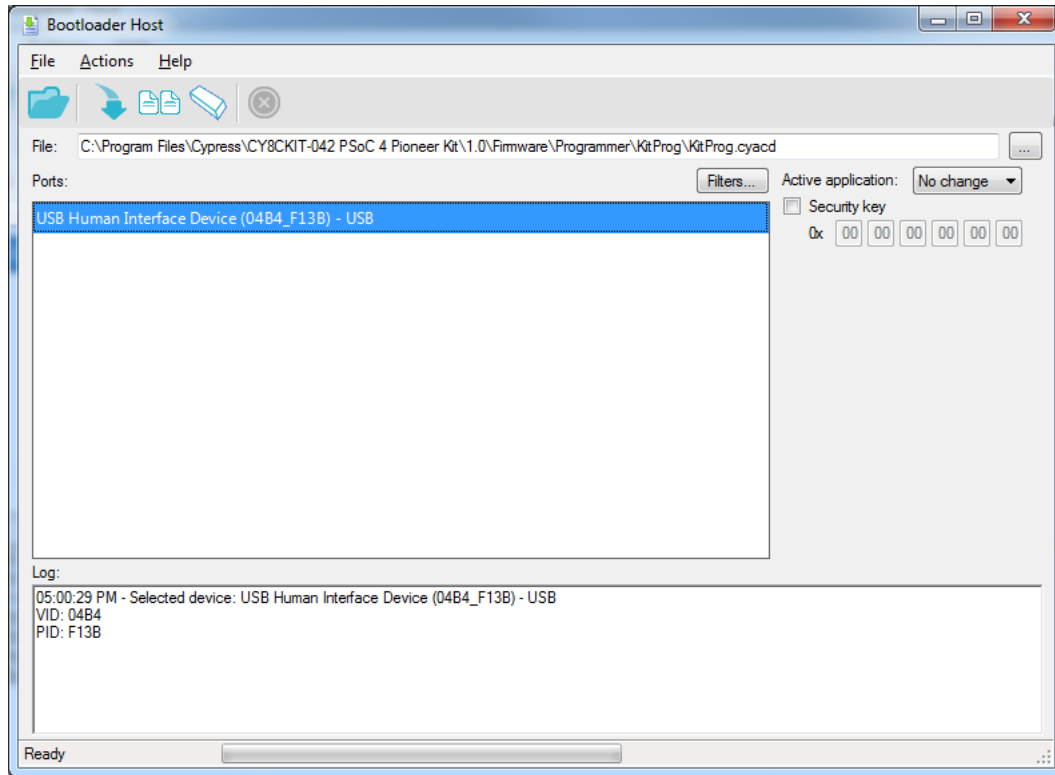

5. Click the **Program** button (or menu item **Actions > Program**) to restore the factory-program by bootloading it onto the PSoC 5LP.

- After programming has completed, the following message appears: “Programming Finished Successfully”.

Figure 6-60. Programming Finished Successfully

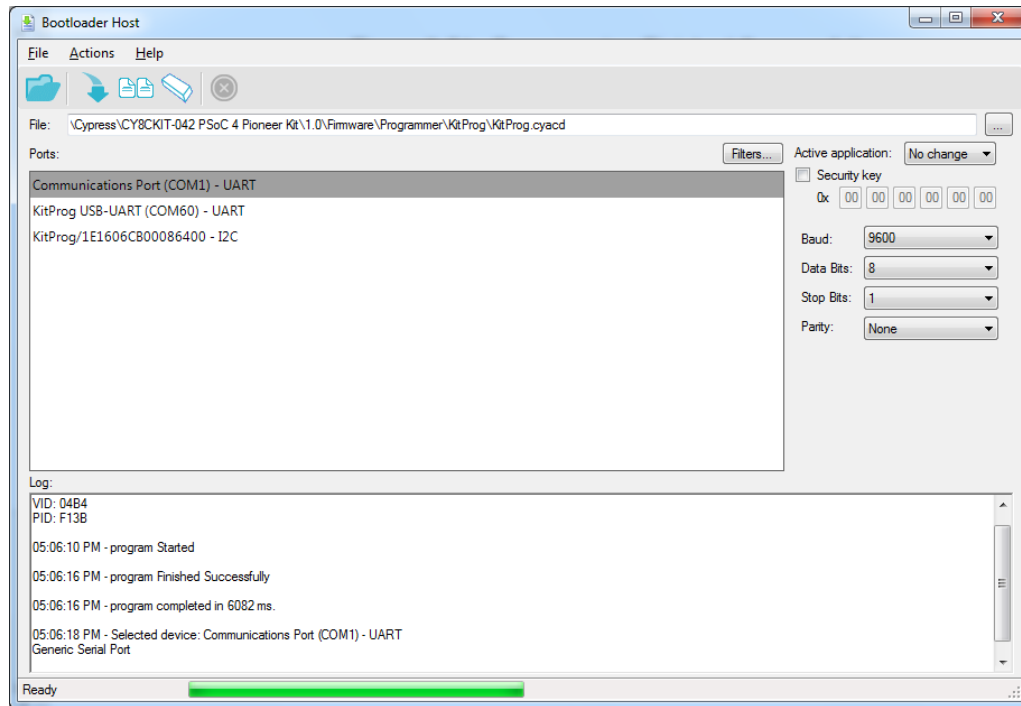

- The factory program is now successfully restored on the PSoC 5LP. It can be used as the programmer/debugger for the PSoC 4 device.

6.4.2 PSoC 5LP is Programmed with a Standard Application

If PSoC 5LP is programmed with a standard application, restore the factory program by using the following method.

- Launch PSoC Programmer from **Start > Cypress > PSoC Programmer <version>**.
- Use the **File > Open** menu to load the *KitProg.hex* factory program hex file, which is shipped with the kit. The default location for this file is: `<Install_Directory>\CY8CKIT-042 PSoC 4 Pioneer Kit\<version>\Firmware\Programmer\KitProg`
- Connect a [CY8CKIT-002 MiniProg3](#) (sold separately) to the computer. The 10-pin connector cable on the MiniProg3 plugs into the header [J7]. Note that the J7 header is unpopulated. For more details, see [Bill of Materials \(BOM\) on page 116](#).

4. Ensure that **MiniProg3** is the selected port in PSoC Programmer and the 10-pin connector (**10p** option) is selected, as shown in the following figure. If the board is not powered over USB, select the **Power Cycle** programming mode.

Figure 6-61. Select MiniProg3

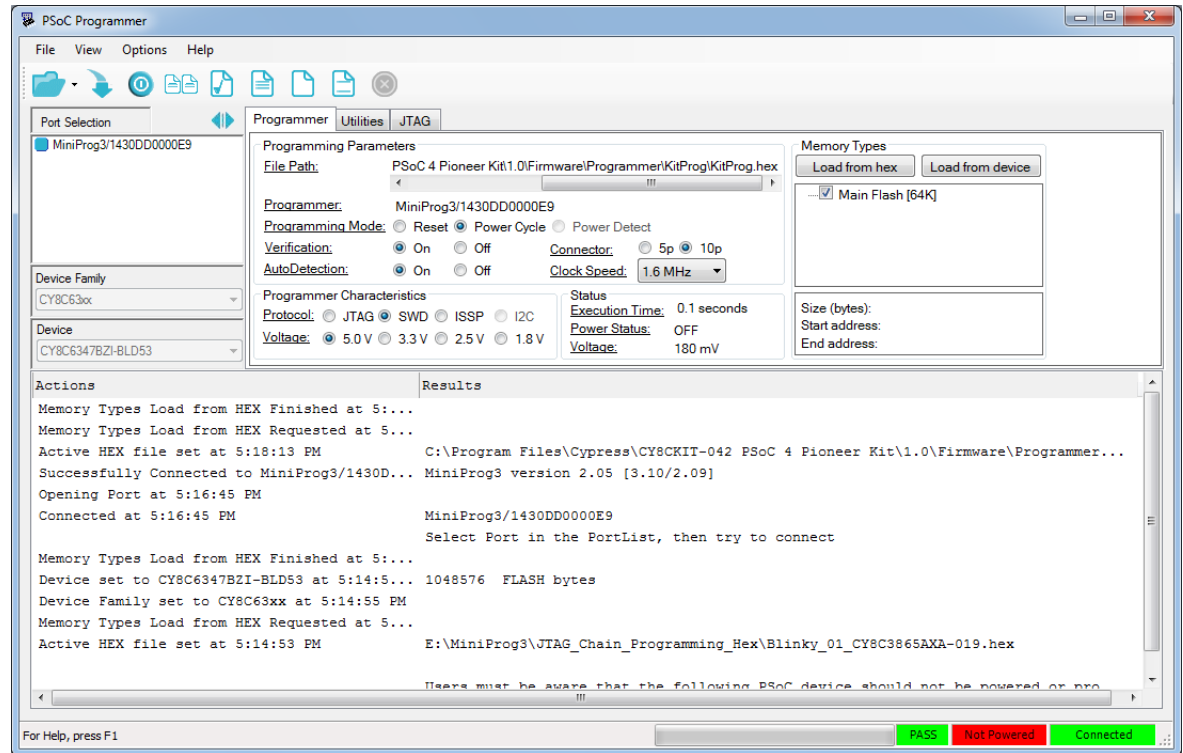

5. When ready, press the **Program** button (or **File > Program**) to program the PSoC 5LP device.

- After programming has completed, the following message appears: “Program Finished at <time>”.

Figure 6-62. Program Finished

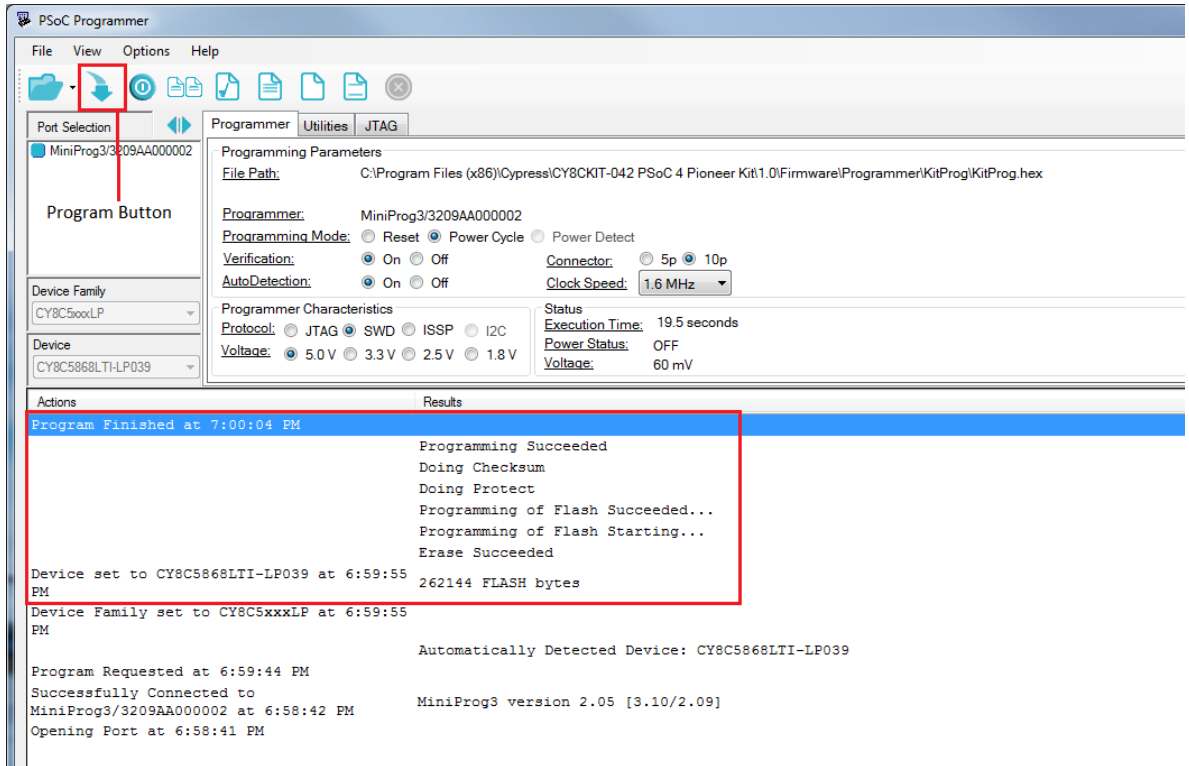

- The factory program is now successfully restored on the PSoC 5LP. It can be used as the programmer/debugger for the PSoC 4 device.

A. Appendix



A.1 CY8CKIT-042 Schematics

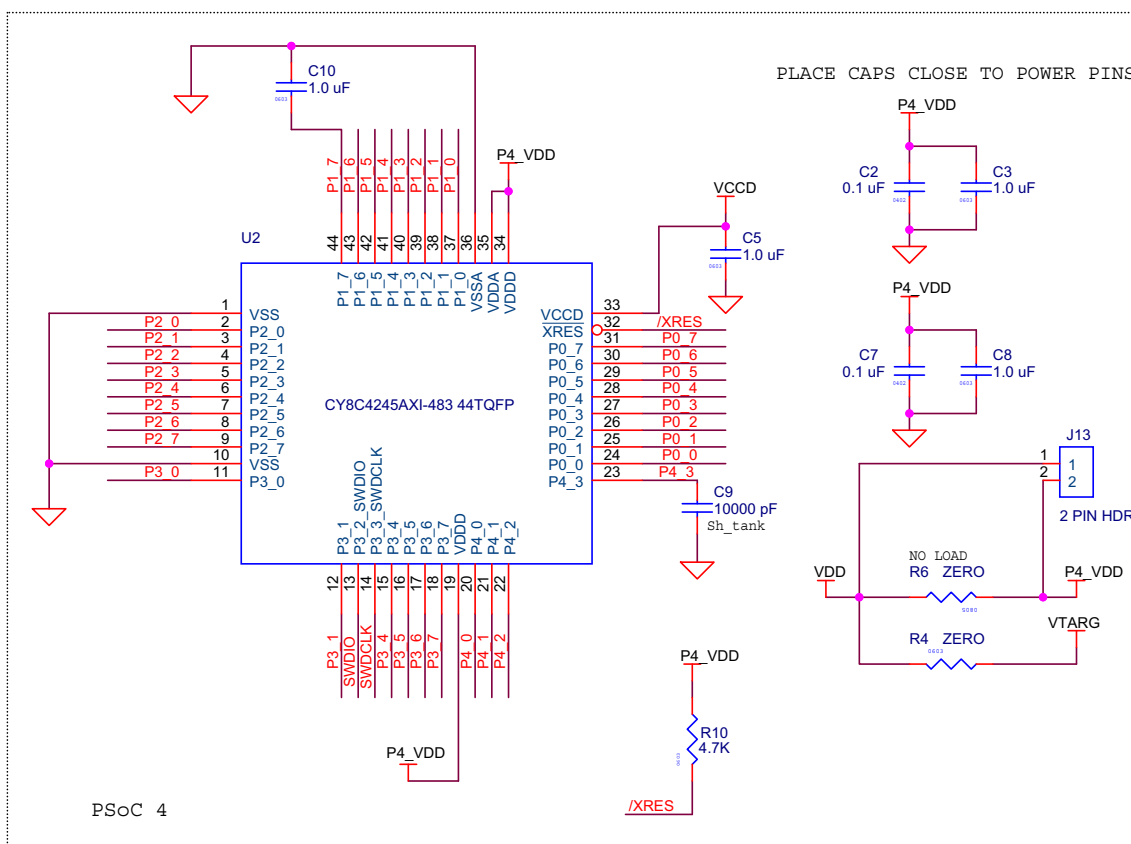

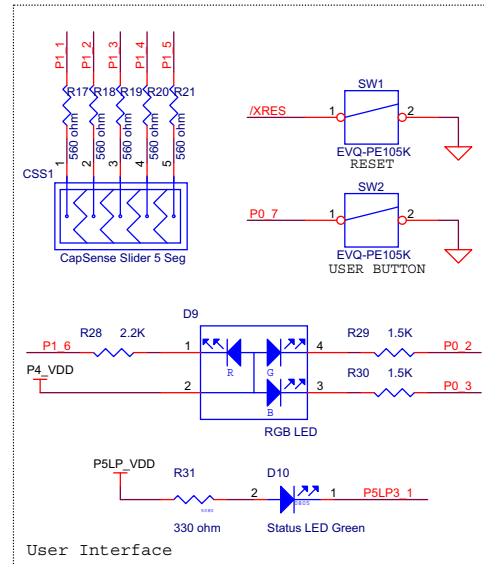
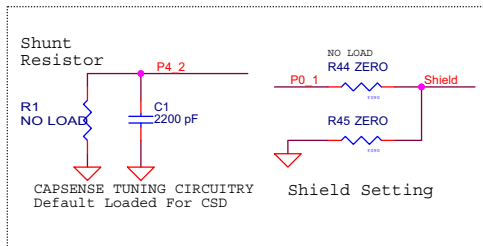
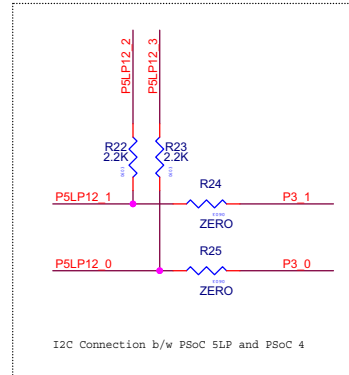
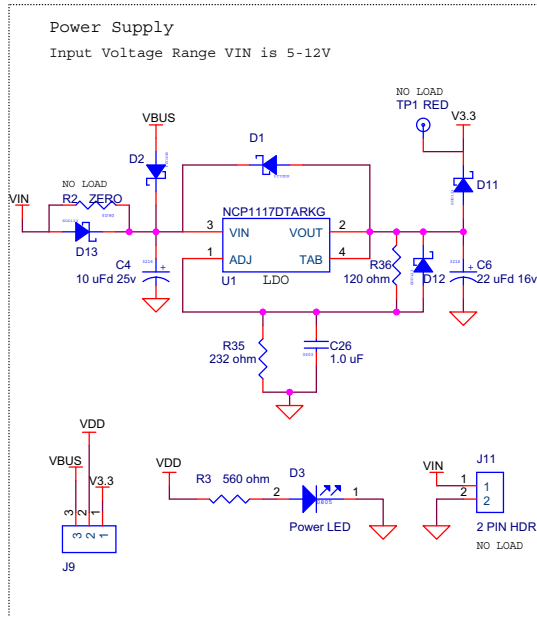

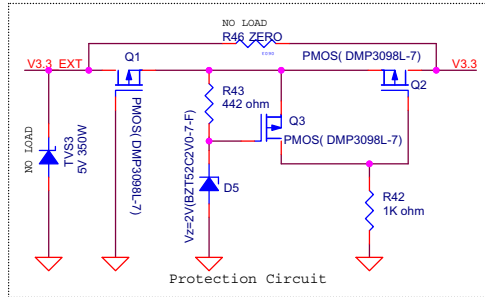
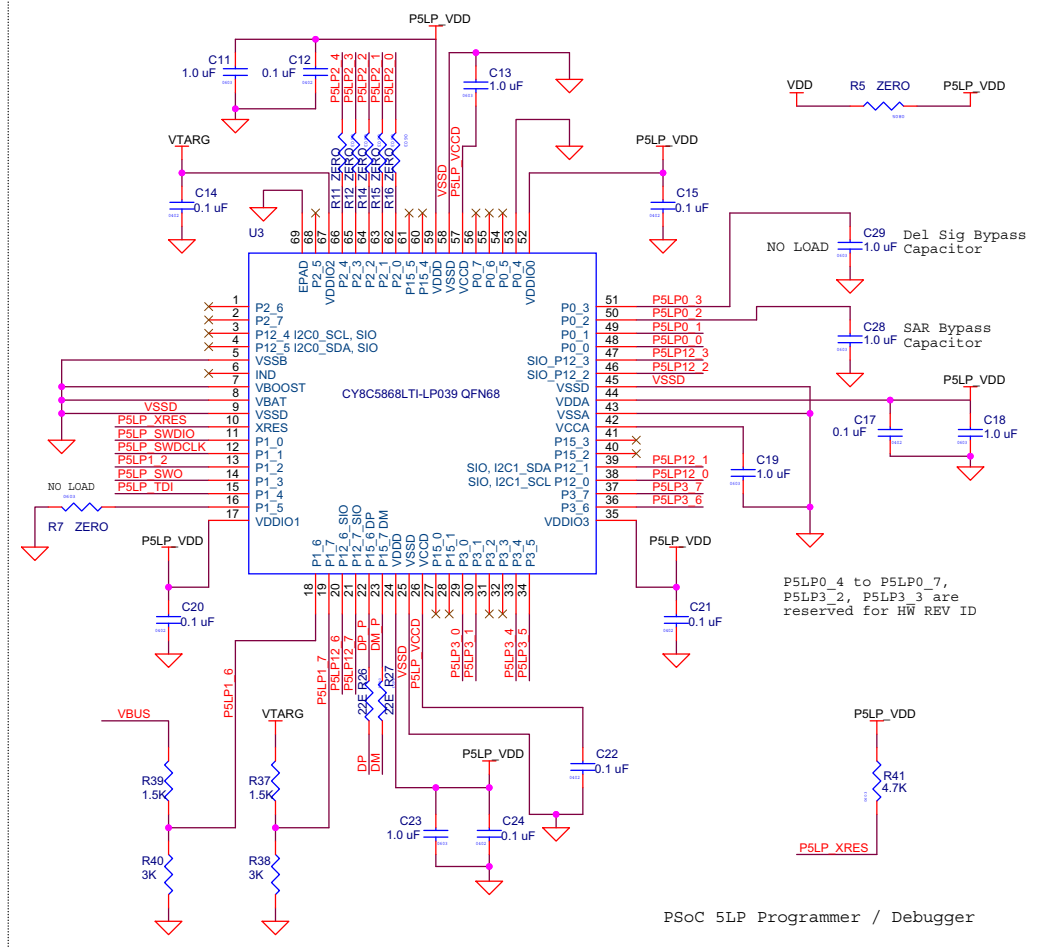

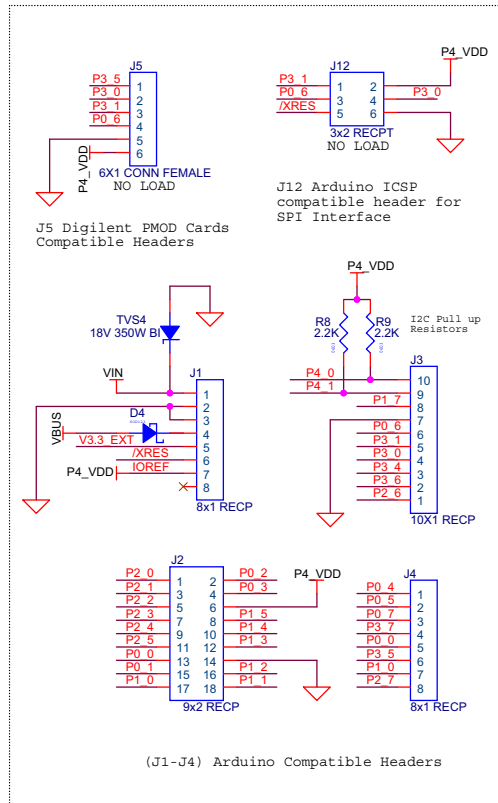
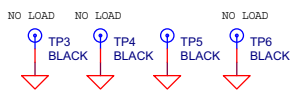
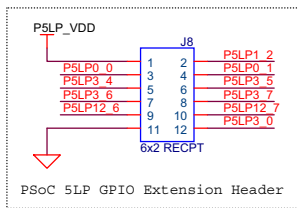
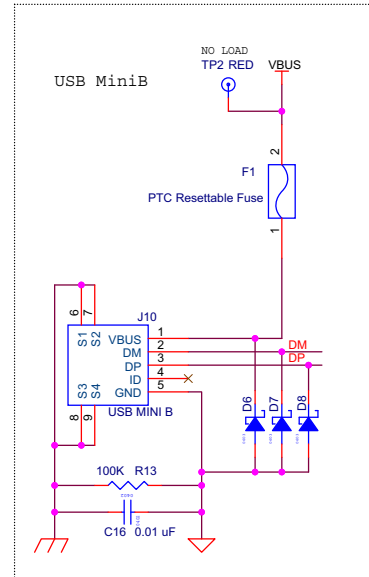
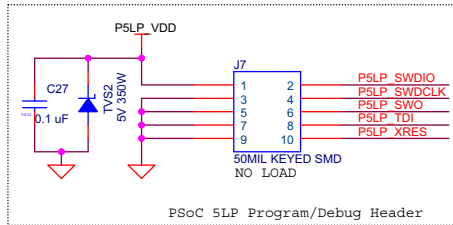
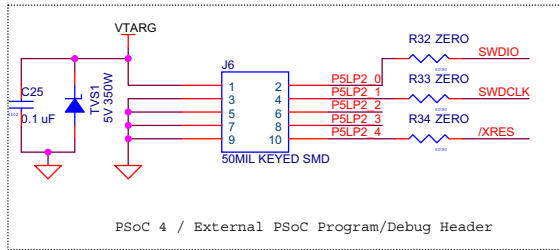

A.2 Pin Assignment Table

This section provides the pin map of the headers and their usage.

A.2.1 Arduino Compatible Headers (J1, J2, J3, J4, and J12)

J1		
Pin	Kit Signal	Description
J1_01	VIN	Input voltage to the board
J1_02	GND	GND
J1_03	GND	GND
J1_04	5V	5 V voltage
J1_05	3.3V	3.3 V voltage
J1_06	RESET	/XRES
J1_07	IOREF	I/O voltage reference
J1_08	NC	Not connected

J2					
Pin	PSoC 4 Signal	PSoC 4 Description	Pin	PSoC 4 Signal	PSoC 4 Description
J2_01	P2[0]	A0 (SARADC input)	J2_02	P0[2]	Comparator 2+
J2_03	P2[1]	A1 (SARADC input)	J2_04	P0[3]	Comparator 2-
J2_05	P2[2]	A2 (SARADC input)	J2_06	VDD	VDD
J2_07	P2[3]	A3 (SARADC input)	J2_08	P1[5]	Opamp 2+
J2_09	P2[4]	A4 (SARADC input)	J2_10	P1[4]	Opamp 2-
J2_11	P2[5]	A5 (SARADC input)	J2_12	P1[3]	Opamp 2out
J2_13	P0[0]	Comparator 1+	J2_14	GND	GND
J2_15	P0[1]	Comparator 1-	J2_16	P1[2]	Opamp 1out
J2_17	P1[0]	Opamp 1+	J2_18	P1[1]	Opamp 1-

J3		
Pin	PSoC 4 Signal	PSoC 4 Description
J3_01	P2[6]	D8
J3_02	P3[6]	D9(PWM)
J3_03	P3[4]	D10(PWM/SS)
J3_04	P3[0]	D11(PWM/MOSI)
J3_05	P3[1]	D12(MISO)
J3_06	P0[6]	D13(SCK)
J3_07	GND	GND
J3_08	P1[7]	AREF
J3_09	P4[1]	SDA
J3_10	P4[0]	SCL

J4		
Pin	PSoC 4 Signal	PSoC 4 Description
J4_01	P0[4]	D0(RX)
J4_02	P0[5]	D1(TX)
J4_03	P0[7]	D2
J4_04	P3[7]	D3(PWM)
J4_05	P0[0]	D4
J4_06	P3[5]	D5(PWM)
J4_07	P1[0]	D6(PWM)
J4_08	P2[7]	D7

J12		
Pin	Kit Signal	PSoC 4 Description
J12_01	P3[1]	MISO
J12_02	PSoC 4_VDD	VDD
J12_03	P0[6]	SCK
J12_04	P3[0]	MOSI
J12_05	/XRES	PSoC 4 RESET
J12_06	GND	GND

A.2.2 Digilent Pmod Cards Support Header (J5)

J5		
Pin	Kit Signal	PSoC 4 Description (Default Pmod Signals)
J5_01	P3[5]	SPI_SS (multiplex with J4_06)
J5_02	P3[0]	SPI_MOSI
J5_03	P3[1]	SPI_MISO
J5_04	P0[6]	SPI_SCK
J5_05	GND	GND
J5_06	VDD	VCC

A.2.3 PSoC 5LP GPIO Header (J8)

J8 is a 2×6 header that connects PSoC 5LP pins to support GPIO controls for custom PSoC 5LP projects.

J8					
Pin	PSoC 5LP Signal	PSoC 5LP Description	Pin	PSoC 5LP Signal	PSoC 5LP Description
J8_01	PSoC 5LP_VDD	VDD	J8_02	P1[2]	Digital I/O
J8_03	P0[0]	Delta Sigma ADC + input	J8_04	P0[1]	Delta Sigma ADC – input
J8_05	P3[4]	SAR – input	J8_06	P3[5]	SAR + input
J8_07	P3[6]	Buffered VDAC	J8_08	P3[7]	Buffered VDAC
J8_09	P12[6]	UART RX	J8_10	P12[7]	UART TX
J8_11	GND	GND	J8_12	P3[0]	IDAC output

A.3 Program and Debug Headers

A.3.1 PSoC 4 Direct Program/Debug Header (J6)

J6							
Pin	PSoC 5LP Signal	PSoC 4 Signal	Description	Pin	PSoC 5LP Signal	PSoC 4 Signal	Description
J6_01	VDD	VDD	VCC	J6_02	P2[0]	P3[2]	TMS/SWDIO
J6_03	GND	GND	GND	J6_04	P2[1]	P3[3]	TCLK/SWCLK
J6_05	GND	GND	GND	J6_06	P2[2]	NC	TDO/SWO
J6_07	NC	GND	GND	J6_08	P2[3]	NC	TDI
J6_09	GND	GND	GND	J6_10	P2[4]	XRES	RESET

A.3.2 PSoC 5LP Direct Program/Debug Header (J7)

J7					
Pin	PSoC 5LP Signal	Description	Pin	PSoC 5LP Signal	Description
J7_01	VDD	VCC	J7_02	P1[0]	TMS/SWDIO
J7_03	GND	GND	J7_04	P1[1]	TCLK/SWCLK
J7_05	GND	GND	J7_06	P1[3]	TDO/SWO
J7_07	GND	GND	J7_08	P1[4]	TDI
J7_09	GND	GND	J7_10	XRES	RESET

A.4 Use of Zero-ohm Resistors and No Load

Unit	Resistor	Usage
Power supply	R2	Solder zero-ohm resistors to access voltage from VBUS (USB).
I2C connection between PSoC 5LP and PSoC 4	R24 and R25	Unsolder the resistors to communicate with an external PSoC using the PSoC 5LP. Removing these will disable the PSoC 4 I2C communication with the PSoC 5LP device.
PSoC 4/external PSoC program/debug header	R32, R33, and R34	Unsolder the resistors to disconnect SWD lines from the PSoC 4. Use J6 to connect and program an external PSoC. Removing these will disable PSoC 4 programming by the PSoC 5LP device.
Protection circuit	R46	Solder zero-ohm resistors to bypass the entire protection circuitry.
CapSense tuning circuitry	R1	Used when Rbleed mode of the CSD is used. To use this feature, you must populate an Rbleed resistor. Refer to the CapSense component datasheet.
CapSense shield setting	R44, R45	Unsolder R45, which connects the shield to ground and solder R44 with zero-ohm resistors to connect Vref via P0_1.
PSoC 4	R4, R6	Unsolder R4 to remove supply to VTARG and solder zero-ohm resistors R6 to supply P4_VDD with VDD instead of J13.
PSoC 5LP programmer/debugger	R11, R12, R14, R15, R16	For future use.
	R5	Unsolder the zero-ohm resistor to cut the VDD supply to PSoC 5LP.
	R7	For future use.

A.5 Error in Firmware/Status Indication in Status LED

	User Indication	Scenario	Action Required by user
1	LED blinks at a fast rate (ON Time = 0.25s, OFF Time = 0.25s)	Bootloadable file is corrupt	Bootload the *.cyacd file over the USB interface, which is shipped with PSoC Programmer using the Bootloader Host GUI shipped with PSoC Creator. The files are located in the PSoC Programmer root installation directory.
2	LED blinks at a slow rate (ON Time = 1.5s, OFF Time = 1.5s)	Entered Bootloader by pressing the PSoC 4 Reset switch	a) Unplug power and plug it in again if you entered this mode by mistake; the LED gives the indication. b) If the mode entry was intentional, bootload the new *.cyacd file using the Bootloader Host tool shipped with PSoC Creator.
3	LED glows steadily	Programmer application is running successfully	USB is enumerated successfully and the programmer is up and running. The PSoC 4 device can now be programmed any time using the onboard PSoC 5LP programmer.

Note: LED status is not applicable when a custom project is running in PSoC 5LP.

A.6 Bill of Materials (BOM)

No.	Qty	Reference	Value	Description	Manufacturer	Mfr Part Number
1				PCB,3.32"x2.1" CAF resistant High Tg ENIG finish, 4 layer, Color = RED, Silk = WHITE.	Cypress	
2	1	C1	2200 pFd	CAP CER 2200PF 50V 5% NP0 0805	Murata	GRM2165C1H222JA01D
3	12	C2,C7,C12,C14,C15,C17,C20,C21,C22,C24,C25,C27	0.1 uFd	CAP .1UF 16V CERAMIC Y5V 0402	Panasonic - ECG	ECJ-0EF1C104Z
4	11	C3,C5,C8,C10,C11,C13,C18,C19,C23,C26,C28	1.0 uFd	CAP CERAMIC 1.0UF 25V X5R 0603 10%	Taiyo Yuden	TMK107BJ105KA-T
5	1	C4	10 uF 25V	CAP TANT 10UF 25V 10% 1210	AVX Corporation	TPSB106K025R1800
6	1	C6	22 uF 16V	CAP TANT 22UF 16V 10% 1210	AVX Corporation	TPSB226K016R0600
7	1	C9	10000 pFd	CAP CER 10000PF 50V 5% NP0 0805	Murata	GRM2195C1H103JA01D
8	1	C16	0.01 uFd	CAP 10000PF 16V CERAMIC 0402 SMD	Panasonic - ECG	ECJ-0EB1C103K
9	6	D1,D2,D4,D11,D12,D13	MBR05	DIODE SCHOTTKY 0.5A 20V SOD-123	Fairchild Semiconductor	MBR0520L
10	1	D3	Power LED Amber	LED AMBER 591NM DIFF LENS 2012	Sharp Microelectronics	LT1ZV40A
11	1	D5	2V Zener	DIODE ZENER 2V 500MW SOD123	Diodes Inc	BZT52C2V0-7-F
12	3	D6, D7, D8	ESD diode	SUPPRESSOR ESD 5VDC 0603 SMD	Bourns Inc.	CG0603MLC-05LE
13	1	D9	RGB LED	LED RED/GREEN/BLUE PLCC4 SMD	Cree, Inc.	CLV1A-FKB-CJ1M1F1BB7R4S3
14	1	D10	Status LED Green	LED GREEN CLEAR 0805 SMD	Chicago Miniature	CMD17-21VGC/TR8
15	1	F1	FUSE	PTC Resettable Fuses 15Volts 100Amps	Bourns	MF-MSMF050-2
16	2	J1, J4	8x1 RECP	CONN HEADER FEMALE 8POS .1" GOLD	Sullins Connector Solutions	PPPC081LFBN-RC
17	1	J2	9x2 RECP	CONN HEADER FMAL 18PS.1" DL GOLD	Sullins Connector Solutions	PPPC092LFBN-RC
18	1	J3	10x1 RECP	CONN HEADER FMALE 10POS .1" GOLD	Sullins Connector Solutions	PPPC101LFBN-RC
19	1	J6	50MIL KEYED SMD	CONN HEADER 10 PIN 50MIL KEYED SMD	Samtec	FTSH-105-01-L-DV-K
20	1	J8	6x2 RECP	CONN HEADER FMAL 12PS.1" DL GOLD	Sullins Connector Solutions	PPPC062LFBN-RC
21	1	J9	3p_jumper	CONN HEADER VERT SGL 3POS GOLD	3M	961103-6404-AR
22	1	J10	USB Mini B	CONN USB MINI AB SMT RIGHT ANGLE	TE Connectivity	1734035-2

No.	Qty	Reference	Value	Description	Manufacturer	Mfr Part Number
23	1	J13	2p_jumper	CONN HEADER VERT SGL 2POS GOLD	3M	961102-6404-AR
24	3	Q1,Q2,Q3	PMOS	MOSFET P-CH 30V 3.8A SOT23-3	Diodes Inc	DMP3098L-7
25	1	R3	560 Ω	RES 560 Ω 1/8W 5% 0805 SMD	Panasonic - ECG	ERJ-6GEYJ561V
26	12	R4,R11,R12,R14,R15, R16,R24,R25,R32,R33 ,R34,R45	ZERO	RES 0.0 Ω 1/10W 0603 SMD	Panasonic-ECG	ERJ-3GEY0R00V
27	1	R5	ZERO	RES 0.0 Ω 1/8W 0805 SMD	Panasonic-ECG	ERJ-6GEY0R00V
28	4	R8,R9,R22,R23	2.2K	RES 2.2 kΩ 1/10W 5% 0603 SMD	Panasonic - ECG	ERJ-3GEYJ222V
29	2	R10,R41	4.7K	RES 4.7 kΩ 1/10W 5% 0603 SMD	Panasonic-ECG	ERJ-3GEYJ472V
30	1	R13	100K	RES 100 kΩ 1/10W 5% 0402 SMD	Panasonic - ECG	ERJ-2GEJ104X
31	5	R17,R18,R19,R20,R21	560 Ω	RES 560 Ω 1/10W 5% 0603 SMD	Panasonic-ECG	ERJ-3GEYJ561V
32	2	R26, R27	22E	RES 22 Ω 1/10W 1% 0603 SMD	Panasonic - ECG	ERJ-3EKF22R0V
33	1	R28	2.2K	RES 2.2 kΩ 1/8W 5% 0805 SMD	Panasonic - ECG	ERJ-6GEYJ222V
34	2	R29,R30	1.5K	RES 1.5 kΩ 1/8W 5% 0805 SMD	Panasonic - ECG	ERJ-6GEYJ152V
35	1	R31	330 Ω	RES 330 Ω 1/8W 5% 0805 SMD	Panasonic - ECG	ERJ-6GEYJ331V
36	1	R35	232 Ω	RES 232 Ω 1/10W 1% 0603 SMD	Panasonic - ECG	ERJ-3EKF2320V
37	1	R36	120 Ω	RES 120 Ω 1/10W 1% 0603 SMD	Panasonic - ECG	ERJ-3EKF1200V
38	2	R37,R39	1.5K	RES 1.5K Ω 1/10W 5% 0603 SMD	Panasonic - ECG	ERJ-3GEYJ152V
39	2	R38,R40	3K	RES 3.0K Ω 1/10W 5% 0603 SMD	Panasonic - ECG	ERJ-3GEYJ302V
40	1	R42	1K	RES 1K Ω 1/8W 5% 0805 SMD	Panasonic - ECG	ERJ-6GEYJ102V
41	1	R43	442 Ω	RES 442 Ω 1/10W 1% 0603 SMD	Panasonic - ECG	ERJ-3EKF4420V
42	2	SW1,SW2	SW PUSH-BUTTON	SWITCH TACTILE SPST-NO 0.05A 12V	Panasonic - ECG	EVQ-PE105K
43	1	TP5	BLACK	TEST POINT PC MINI .040"D Black	Keystone Electronics	5001
44	2	TVS1,TVS2	5V 350W	TVS UNIDIR 350W 5V SOD-323	Diodes Inc.	SD05-7
45	1	TVS4	18V 350W	TVS DIODE 18V 1CH BI SMD	Bourns Inc.	CDSOD323-T18C
46	1	U1	NCP1117DT ARKG	NCP1117DTARKG	ON Semiconductor	NCP1117DTARKG
47	1	U2	PSoC 4 (CY8C4245A XI-483)	44TQFP PSoC4A target chip	Cypress Semicon-ductor	CY8C4245AXI-483
48	1	U3	PSoC 5LP (CY8C5868L TI-LP039)	68QFN PSoC 5LP chip for USB debug channel and USB-Serial interface	Cypress Semicon-ductor	CY8C5868LTI-LP039
No Load Components						
49	1	C29	1.0 uFd	CAP CERAMIC 1.0UF 25V X5R 0603 10%	Taiyo Yuden	TMK107BJ105KA-T

No.	Qty	Reference	Value	Description	Manufacturer	Mfr Part Number
50	1	J5	6X1 RECP RA	CONN FEMALE 6POS .100" R/A GOLD	Sullins Connector Solutions	PPPC061LGBN-RC
51	1	J7	50MIL KEYED SMD	CONN HEADER 10 PIN 50MIL KEYED SMD	Samtec	FTSH-105-01-L-DV-K
52	1	J11	2 PIN HDR	CONN HEADER FEMALE 2POS .1" GOLD	Sullins Connector Solutions	PPPC021LFBN-RC
53	1	J12	3x2 RECPT	CONN HEADER FMAL 6PS .1" DL GOLD	Sullins Connector Solutions	PPPC032LFBN-RC
54	5	R1,R2,R7,R44,R46	ZERO	RES 0.0 Ω 1/10W 0603 SMD	Panasonic-ECG	ERJ-3GEY0R00V
55	1	R6	ZERO	RES 0.0 Ω 1/8W 0805 SMD	Panasonic-ECG	ERJ-6GEY0R00V
56	2	TP1,TP2	RED	TEST POINT PC MINI .040"D RED	Keystone Electronics	5000
57	3	TP3,TP4,TP6	BLACK	TEST POINT PC MINI .040"D Black	Keystone Electronics	5001
58	1	TVS3	5V 350W	TVS UNIDIR 350W 5V SOD-323	Dioded Inc.	SD05-7
Install on Bottom of PCB As per the Silk Screen in the Corners						
59	4	N/A	N/A	BUMPON CYLINDRICAL.312X.215 BLACK	3M	SJ61A6
Special Jumper Installation Instructions						
60	1	J9	Install jumper across pins 1 and 2	Rectangular Connectors MINI JUMPER GF 6.0MM CLOSE TYPE BLACK	Kobiconn	151-8010-E
61	1	J13	Install jumper across pins 1 and 2	Rectangular Connectors MINI JUMPER GF 6.0MM CLOSE TYPE BLACK	Kobiconn	151-8010-E
Label						
62	1	N/A	N/A	LBL, Kit Product Identification Label, Vendor Code, Datecode, Serial Number CY8CKIT-042 Rev** (YYWWV-VXXXXX)	Cypress Semiconductor	
63	1	N/A	N/A	LBL, PCBA Anti-Static Warning, 10mm X 10mm	Cypress Semiconductor	
64	1	N/A	N/A	Assembly Adhesive Label, Manufacturing ID	Cypress Semiconductor	
65	1	N/A	N/A	Kit QR code	Cypress Semiconductor	

A.7 Regulatory Compliance Information

The CY8CKIT-042 PSoc 4 Pioneer Kit has been tested and verified to comply with the following electromagnetic compatibility (EMC) regulations:

- EN 55022:2010 Class A - Emissions
- EN 55024:2010 Class A - Immunity

A.8 Migrating projects across different Pioneer series kits

All Cypress Pioneer series kits are Arduino Uno compatible and have some common on-board peripherals such as RGB LED, CapSense and User Switch. However, the pin mapping in each of the boards is different due to differences in pin functions of the PSoC device used. This guide lists the pin maps of the Pioneer series kits to allow for easy migration of projects across different kits.

In some cases, the pins available on the Pioneer kit headers are a superset of the standard Arduino Uno pins. For example J2 contains only 1 row of pins on the Arduino Uno pinout while it contains 2 rows of pins on many of the Pioneer series kits.

Figure A-1. Pioneer series kits pin map

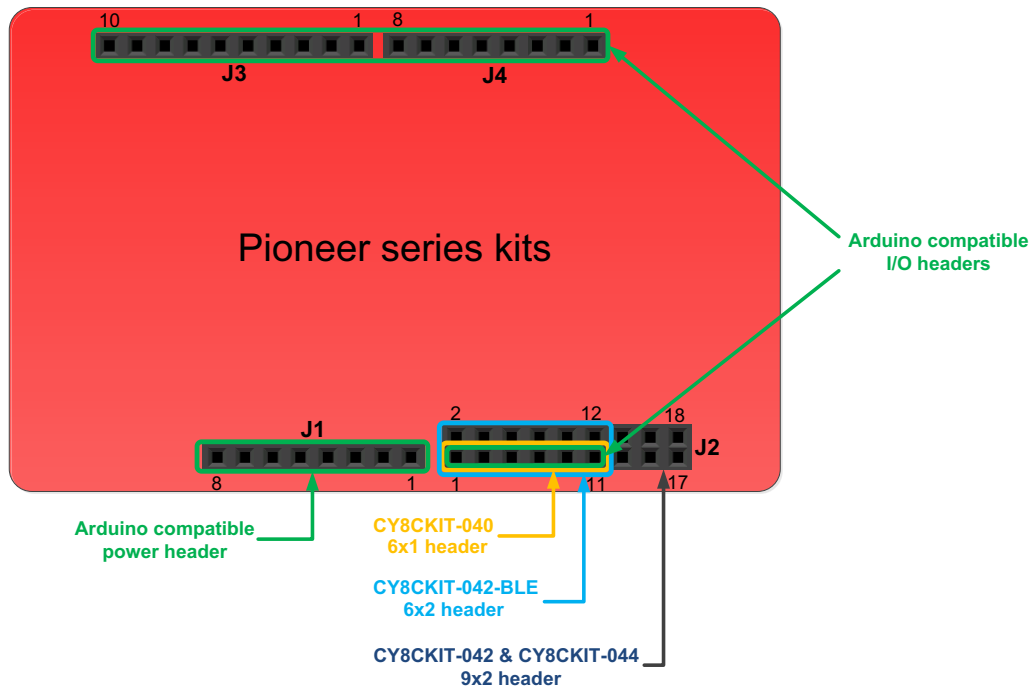

A.8.1 Arduino Uno Compatible Headers

J1 Arduino Compatible Header Pin Map					
Pin #	Arduino Pin	Pioneer series kits			
		CY8CKIT-042	CY8CKIT-040	CY8CKIT-042-BLE	CY8CKIT-044
1	VIN	VIN	VIN	VIN	VIN
2	GND	GND	GND	GND	GND
3	GND	GND	GND	GND	GND
4	5V	V5.0	V5.0	V5.0	V5.0
5	3.3V	V3.3	V3.3	V3.3	V3.3
6	RESET	RESET	RESET	RESET	RESET
7	IOREF	P4.VDD	P4.VDD	BLE.VDD	P4.VDD
8	NC	NC	NC	NC	NC

J2 Arduino Compatible Header Pin Map					
Pin #	Arduino Pin	Pioneer series kits			
		CY8CKIT-042	CY8CKIT-040	CY8CKIT-042-BLE	CY8CKIT-044
1	A0	P2[0]	P0[0]	P3[0]	P2[0]
2	–	P0[2]*	–	P2[0]	P2[6]*
3	A1	P2[1]	P0[1]	P3[1]	P2[1]
4	–	P0[3]*	–	P2[1]*	P6[5]*
5	A2	P2[2]	P0[2]*	P3[2]	P2[2]
6	–	P4_VDD	–	P2[2]*	P0[6]*
7	A3	P2[3]	P0[4]*	P3[3]	P2[3]
8	–	P1[5]*	–	P2[3]*	P4[4]*
9	A4	P2[4]	P1[3]	P3[4]	P2[4]
10	–	P1[4]*	–	P2[4]*	P4[5]*
11	A5	P2[5]	P1[2]	P3[5]	P2[5]
12	–	P1[3]*	–	P2[5]*	P4[6]*
13	–	P0[0]	–	–	P0[0]
14	–	GND	–	–	GND
15	–	P0[1]	–	–	P0[1]
16	–	P1[2]*	–	–	P3[4]*
17	–	P1[0]	–	–	P0[7]*
18	–	P1[1]*	–	–	P3[5]*

* These pins are also used for on-board peripherals. See the tables in the On-Board Peripherals section below for details.

J3 Arduino Compatible Header Pin Map					
Pin #	Arduino Pin	Pioneer series kits			
		CY8CKIT-042	CY8CKIT-040	CY8CKIT-042-BLE	CY8CKIT-044
1	D8	P2[6]	P1[4]	P0[5]	P0[2]
2	D9	P3[6]	P1[5]	P0[4]	P0[3]
3	D10	P3[4]	P1[6]	P0[2]	P2[7]
4	D11	P3[0]	P1[1]*	P0[0]	P6[0]
5	D12	P3[1]	P3[1]	P0[1]	P6[1]
6	D13	P0[6]	P1[7]	P0[3]	P6[2]
7	GND	GND	GND	GND	GND
8	AREF	P1[7]	NC	VREF	P1[7]
9	SDA	P4[1]	P1[3]	P3[4]	P4[1]
10	SCL	P4[0]	P1[2]	P3[5]	P4[0]

* These pins are also used for on-board peripherals. See the tables in the On-Board Peripherals section below for connection details.

J4 Arduino Compatible Header Pin Map					
Pin #	Arduino Pin	Pioneer series kits			
		CY8CKIT-042	CY8CKIT-040	CY8CKIT-042-BLE	CY8CKIT-044
1	D0	P0[4]	P0[5]	P1[4]	P3[0]
2	D1	P0[5]	P0[6]	P1[5]	P3[1]
3	D2	P0[7]*	P0[7]	P1[6]	P1[0]
4	D3	P3[7]	P3[2]*	P1[7]	P1[1]
5	D4	P0[0]	P0[3]	P1[3]	P1[2]
6	D5	P3[5]	P3[0]	P1[2]	P1[3]
7	D6	P1[0]	P1[0]	P1[1]	P5[3]
8	D7	P2[7]	P2[0]*	P1[0]	P5[5]

* These pins are also used for on-board peripherals. See the tables in the On-Board Peripherals section below for connection details.

A.8.2 On-Board Peripherals

CapSense Pin Map					
Pin #	Description	Pioneer series kits			
		CY8CKIT-042 (Linear Slider)	CY8CKIT-040	CY8CKIT-042-BLE (Linear Slider)	CY8CKIT-044 (Gesture Pad)
1	CSS1	P1[1]	–	P2[1]	P4[4]
2	CSS2	P1[2]	–	P2[2]	P4[5]
3	CSS3	P1[3]	–	P2[3]	P4[6]
4	CSS4	P1[4]	–	P2[4]	P3[4]
5	CSS5	P1[5]	–	P2[5]	P3[5]
6	CMOD	P4[2]	P0[4]	P4[0]	P4[2]
7	CTANK	P4[3]	P0[2]	P4[1]	P4[3]

Proximity header Pin Map					
Pin #	Description	Pioneer series kits			
		CY8CKIT-042	CY8CKIT-040	CY8CKIT-042-BLE	CY8CKIT-044
1	PROXIMITY	–	P2[0]	P2[0]	P3[7]
2		–	–	–	P3[6]

RGB LED Pin Map					
Pin #	Color	Pioneer series kits			
		CY8CKIT-042	CY8CKIT-040	CY8CKIT-042-BLE	CY8CKIT-044
1	Red	P1[6]	P3[2]	P2[6]	P0[6]
2	Green	P0[2]	P1[1]	P3[6]	P2[6]
3	Blue	P0[3]	P0[2]	P3[7]	P6[5]

User Switch Pin Map					
Pin #	Description	Pioneer series kits			
		CY8CKIT-042	CY8CKIT-040	CY8CKIT-042-BLE	CY8CKIT-044
1	SW2	P0[7]	–	P2[7]	P0[7]

Revision History



Document Revision History

Document Title: CY8CKIT-042 PSoC 4 Pioneer Kit Guide			
Document Number: 001-86371			
Revision	ECN#	Issue Date	Description of Change
**	3978908	04/23/2013	Initial version of kit guide.
*A	3981609	04/25/2013	Minor changes across the guide.
*B	4008979	05/23/2013	Minor changes across the guide. Updated Introduction chapter on page 7 : Updated "Kit Contents" on page 7: Updated Figure 1-1 . Updated Advanced Topics chapter on page 64 : Added "PSoC 5LP Factory Program Restore Instructions" on page 99.
*C	4107338	08/23/2013	Minor changes across the guide. Updated Code Examples chapter on page 43 : Updated "Using the Kit Code Examples" on page 43: Updated Figure 5-2 . Updated Figure 5-3 .
*D	4202835	11/26/2013	Updated PSoC Creator images. Added figure captions. Updated Introduction chapter on page 7 : Updated "Additional Learning Resources" on page 10: Updated PSoC Creator training web link. Updated Code Examples chapter on page 43 : Modified the CapSense code example.
*E	4757883	05/07/2015	Updated Introduction chapter on page 7 : Updated "Additional Learning Resources" on page 10: Updated description. Updated "PSoC Creator Code Examples" on page 12: Updated Figure 1-4 .

Document Revision History (*continued*)

Document Title: CY8CKIT-042 PSoC 4 Pioneer Kit Guide			
Document Number: 001-86371			
Revision	ECN#	Issue Date	Description of Change
*E (cont.)	4757883	05/07/2015	<p>Updated Software Installation chapter on page 14:</p> <p>Updated "Install Kit Software" on page 14:</p> <p>Updated description.</p> <p>Updated "Install Kit Software" on page 14:</p> <p>Updated description.</p> <p>Updated "Develop Code Fast and Easy with Code Examples" on page 17:</p> <p>Updated Figure 2-3.</p> <p>Updated Figure 2-4.</p> <p>Updated "Open an Example Project in PSoC Creator" on page 19:</p> <p>Updated Figure 2-6.</p> <p>Updated Kit Operation chapter on page 17:</p> <p>Updated "KitProg USB Connection" on page 18:</p> <p>Updated Table 3-1:</p> <p>Updated entire table.</p> <p>Removed figure "KitProg Driver Installation".</p> <p>Updated Figure 3-2.</p> <p>Updated "Programming and Debugging PSoC 4" on page 19:</p> <p>Updated "Using CY8CKIT-002 MiniProg3 Programmer and Debugger" on page 21:</p> <p>Updated Figure 3-8.</p> <p>Updated description.</p> <p>Updated Hardware chapter on page 27:</p> <p>Updated "Functional Description" on page 30:</p> <p>Updated "Arduino Compatible Headers (J1, J2, J3, J4, and J12 - unpopulated)" on page 36:</p> <p>Updated description.</p>

Document Revision History *(continued)*

Document Title: CY8CKIT-042 PSoC 4 Pioneer Kit Guide			
Document Number: 001-86371			
Revision	ECN#	Issue Date	Description of Change
*E (cont.)	4757883	05/07/2015	<p>Updated Code Examples chapter on page 43: Updated description.</p> <p>Updated "Blinking LED" on page 46: Updated "Hardware Connections" on page 46: Updated Table 5-1: Updated details in "Pin Name" column. Updated Figure 5-8. Updated "Flow Chart" on page 47: Updated description. Updated "PWM" on page 48: Updated "Hardware Connections" on page 48: Updated Table 5-2: Updated details in "Pin Name" column. Updated Figure 5-12. Updated "Deep Sleep" on page 50: Updated "Hardware Connections" on page 50: Updated Table 5-3: Updated details in "Pin Name" column. Updated Figure 5-15. Updated "CapSense" on page 53: Updated "CapSense (Without Tuning)" on page 53: Updated "Hardware Connections" on page 54: Updated Table 5-4: Updated details in "Pin Name" column. Updated Figure 5-19. Updated "CapSense (With Tuning)" on page 56: Updated "Launching Tuner GUI" on page 57: Updated Figure 5-23. Updated Figure 5-24. Updated "Verify Output" on page 60: Updated description. Updated Figure 5-26. Updated Figure 5-27. Updated Figure 5-28. Updated Figure 5-29.</p>

Document Revision History (*continued*)

Document Title: CY8CKIT-042 PSoC 4 Pioneer Kit Guide			
Document Number: 001-86371			
Revision	ECN#	Issue Date	Description of Change
*E (cont.)	4757883	05/07/2015	<p>Updated Advanced Topics chapter on page 64:</p> <p>Updated "Using PSoC 5LP as a USB-UART Bridge" on page 64:</p> <p>Updated description.</p> <p>Updated Figure 6-1.</p> <p>Updated Figure 6-4.</p> <p>Updated Figure 6-6.</p> <p>Updated Figure 6-7.</p> <p>Updated Figure 6-8.</p> <p>Updated Figure 6-9.</p> <p>Updated "Using PSoC 5LP as USB-I2C Bridge" on page 78:</p> <p>Updated description.</p> <p>Updated Figure 6-21.</p> <p>Updated Figure 6-24.</p> <p>Updated Figure 6-26.</p> <p>Updated Figure 6-27.</p> <p>Added Figure 6-28.</p> <p>Updated Figure 6-29.</p> <p>Updated "Developing Applications for PSoC 5LP" on page 87:</p> <p>Updated "Building a Bootloadable Project for PSoC 5LP" on page 87:</p> <p>Updated description.</p> <p>Updated Figure 6-37.</p> <p>Updated Figure 6-41.</p> <p>Added Figure 6-45.</p> <p>Updated Figure 6-46.</p> <p>Updated "Building a Normal Project for PSoC 5LP" on page 96:</p> <p>Updated Figure 6-51.</p> <p>Updated "PSoC 5LP Factory Program Restore Instructions" on page 99:</p> <p>Updated "PSoC 5LP is Programmed with a Bootloadable Application" on page 99:</p> <p>Updated "Restore PSoC 5LP Factory Program Using PSoC Programmer" on page 99:</p> <p>Updated description.</p> <p>Updated "PSoC 5LP is Programmed with a Standard Application" on page 104:</p> <p>Updated description.</p> <p>Updated Appendix chapter on page 107:</p> <p>Updated "CY8CKIT-042 Schematics" on page 107:</p> <p>Updated entire section.</p> <p>Updated "Use of Zero-ohm Resistors and No Load" on page 115:</p> <p>Updated table.</p> <p>Added "Migrating projects across different Pioneer series kits" on page 119.</p>
*F	4897811	09/14/2015	<p>Updated images.</p> <p>Fixed hyperlinks.</p>

Document Revision History (*continued*)

Document Title: CY8CKIT-042 PSoC 4 Pioneer Kit Guide			
Document Number: 001-86371			
Revision	ECN#	Issue Date	Description of Change
*G	5201185	04/01/2016	No technical updates. Completing Sunset Review.
*H	5740267	05/17/2017	Updated Cypress Logo and Copyright.
*I	6111693	03/27/2018	Updated images. Minor content updates throughout the document. Updated schematics.
*J	6114249	03/29/2018	Updated Code Examples chapter on page 43: Updated "CapSense" on page 53: Updated "CapSense (With Tuning)" on page 56: Updated "Launching Tuner GUI" on page 57 (Updated Figure 5-24 and Figure 5-25).
*K	6734369	12/11/2019	Updated Introduction chapter on page 7: Updated "Kit Contents" on page 7: Updated description. Updated "Additional Learning Resources" on page 10: Updated hyperlinks for "Application Notes and Code Examples" and "Technical Reference Manuals (TRM)". Updated "PSoC Creator Help" on page 12: Updated hyperlinks. Updated Kit Operation chapter on page 17: Updated "KitProg USB Connection" on page 18: Replaced "Pioneer Kit" with "KitProg" in heading. Updated "Programming and Debugging PSoC 4" on page 19: Updated "Using the Onboard PSoC 5LP Programmer and Debugger" on page 19: Updated Figure 3-4 . Updated "USB-I2C Bridge" on page 24: Updated description. Updated Hardware chapter on page 27: Updated "Theory of Operation" on page 29: Updated description. Updated "Functional Description" on page 30: Updated "Diligent Pmod Compatible Header (J5 - unpopulated)" on page 38: Updated description. Updated "Pioneer Board LEDs" on page 41: Updated Figure 4-15 (Updated figure caption only).

Document Revision History (*continued*)

Document Title: CY8CKIT-042 PSoC 4 Pioneer Kit Guide			
Document Number: 001-86371			
Revision	ECN#	Issue Date	Description of Change
*K (cont.)	6734369	12/11/2019	<p>Updated Code Examples chapter on page 43:</p> <p>Updated "PWM" on page 48:</p> <p>Updated "Project Description" on page 48:</p> <p>Updated description.</p> <p>Updated Advanced Topics chapter on page 64:</p> <p>Updated "Developing Applications for PSoC 5LP" on page 87:</p> <p>Updated Figure 6-35.</p> <p>Updated "Building a Bootloadable Project for PSoC 5LP" on page 87:</p> <p>Updated description.</p> <p>Updated "PSoC 5LP Factory Program Restore Instructions" on page 99:</p> <p>Updated "PSoC 5LP is Programmed with a Bootloadable Application" on page 99:</p> <p>Updated "Restore PSoC 5LP Factory Program Using PSoC Programmer" on page 99 (Updated description).</p> <p>Updated "Restore PSoC 5LP Factory Program Using Bootloader Host Tool" on page 102 (Updated description).</p> <p>Updated "PSoC 5LP is Programmed with a Standard Application" on page 104:</p> <p>Updated description.</p> <p>Updated to new template.</p>