Programmable Linear Output Hall Effect Sensor

FEATURES

- Rail-to-rail output
- Programmability at end-of-line
- Wide sensitivity range
 - 8mV/Gs to 24mV/Gs
- Temperature-stable quiescent voltage output and sensitivity
- Output voltage and sensitivity are independent with V_{DD} over the range of 4.5V—5.5V
- Wide ambient temperature range: -40°C to 125°C
- Resistant to mechanical stress
- Under voltage lock-out (UVLO)
- Precise recoverability after temperature cycling
- 3-pin SIP package for easy integration

APPLICATIONS

- Current sensor for solar energy will flow box
- Angular sensing
- Over current detection circuit
- Damper controls



DESCRIPTION

The SC4616 is designed specifically for angular position, and DC current measurement etc. The accuracy of this device is enhanced via programmability on the output pin for end-of-line optimization without the added complexity and cost of a fully programmable device. The programmable nature of the SC4616 enables it to account for manufacturing tolerances in the final current sensing module assembly.

The radiometric Hall effect device provides a voltage output that is proportional to the applied magnetic field. Both the quiescent voltage output and magnetic sensitivity are user adjustable. The quiescent voltage output can be set to 2.5V, and the sensitivity adjusted between 8.0 mV/Gs and 24.0 mV/Gs. Programming selections also exist for output polarity.

Each Bi-CMOS monolithic circuit integrates a Hall element, temperature-compensating circuitry to reduce the intrinsic sensitivity drift of the Hall element, a small-signal high-gain amplifier, a low-impedance output stage, a proprietary dynamic offset cancellation technique and trimming unit.

It is packaged in a thin 3-pin SIP package to allow for easy integration with a magnetic core to create a highly accurate current sensing module.

CONTENTS

FEATURES	- 1 -	OPERATING CHARACTERISTICS	- 6 -
APPLICATIONS	- 1 -	OPERATING CHARACTERISTICS(continued)	- 7 -
DESCRIPTION	- 1 -	FUNCTION DESCRIPTION	- 8 -
BLOCK DIAGRAM	- 3 -	TYPICAL APPLICATION	- 9 -
ORDERING INFORMATION	- 3 -	PACKAGE INFORMATION	- 10 -
TERMINAL CONFIGURATION	- 4 -	REVISION HISTORY	- 11 -
ABSOLUTE MAXIMUM RATINGS	- 5 -		
ESD PROTECTION	- 5 -		

BLOCK DIAGRAM

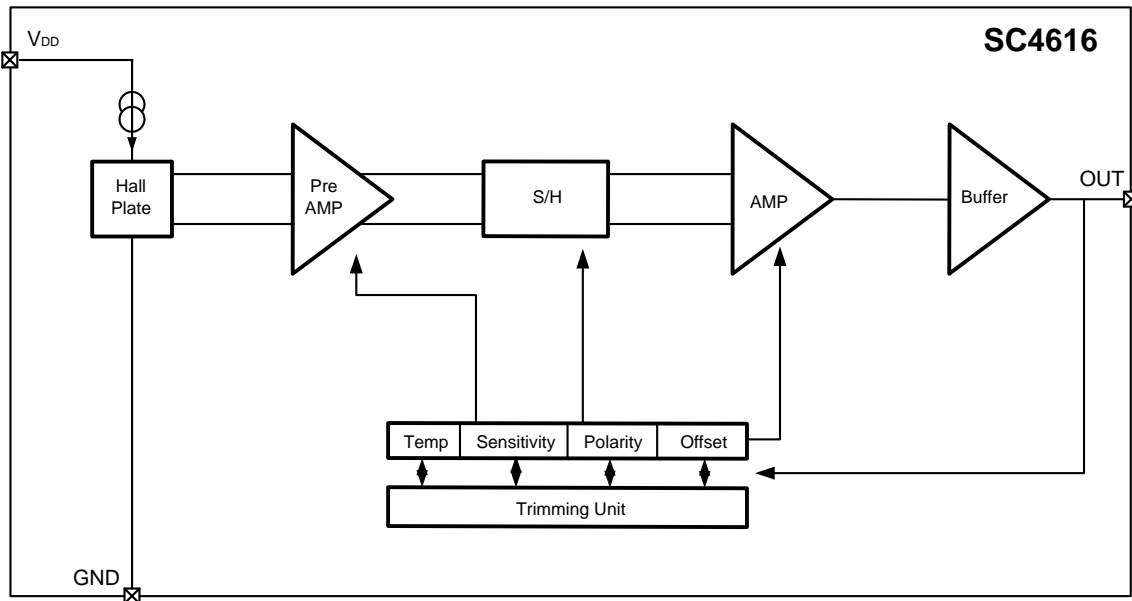

ORDERING INFORMATION

Part Number	Packing	Mounting	Ambient, T _A	Marking
SC4616UA	Bulk, 1000 pcs/bag	3-pin SIP	-40°C to 125°C	4616

TERMINAL CONFIGURATION

3-Terminal SIP
UA Package
(Top View)

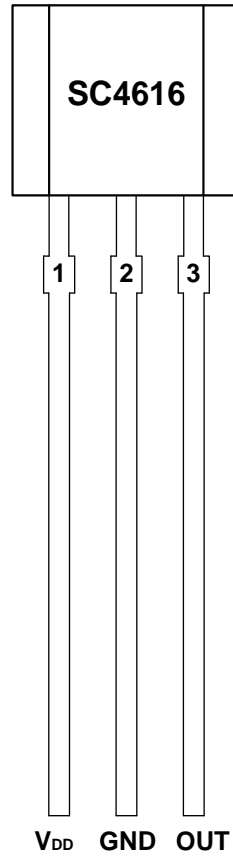

Terminal		Type	Description
Name	Number		
V _{DD}	1	PWR	4.5V ~ 5.5 V power supply
GND	2	Ground	Ground terminal
OUT	3	OUT	Output terminal

ABSOLUTE MAXIMUM RATINGS

over operating free-air temperature range

Parameter	Symbol	Min.	Max.	Unit
Power supply voltage	V_{DD}	-0.5	6.0	V
Output terminal voltage	V_{OUT}	-0.3	6.0	V
Supply current	I_{DD}	--	20	mA
Output current	I_{OUT}	--	3	mA
Operating ambient temperature	T_A	-40	125	°C
Operating junction temperature	T_J	-50	165	°C
Storage temperature	T_{STG}	-65	170	°C

Note: Stresses above those listed here may cause permanent damage to the device. Exposure to absolute maximum rating conditions for extended periods may affect device reliability.

ESD PROTECTION

Human Body Model (HBM) tests according to: standard JEDEC JS-001-2017

Parameter	Symbol	Min.	Max.	Units
HBM ESD stress voltage	V_{ESD}	-4000	4000	V

OPERATING CHARACTERISTICS

over operating free-air temperature range (unless otherwise noted)

Parameter	Symbol	Test Conditions	Min.	Typ.	Max.	Units
Electrical Characteristics						
Supply Voltage	V_{DD}	Operating voltage	4.5	5	5.5	V
Supply Current	I_{DD}	$V_{DD}=5.0V, T_A=25^\circ C$	3.0	5.0	9.0	mA
Under-voltage Threshold ¹	V_{UVLOHI}	$T_A = 25^\circ C$	--	4.0	--	V
	$V_{UVLOLOW}$	$T_A = 25^\circ C$	--	3.7	--	V
Power-On Time ²	t_{PO}	$T_A = 25^\circ C, V_{OUT}$ to 2.5V	--	6.0	10	μS
Internal Bandwidth	BW_I	Output signal -3dB	3.0	5.0	--	kHz
Chopping Frequency ³	f_C	$T_A = 25^\circ C$	--	500	--	kHz
Output Characteristics						
Output Load Capacitance	C_L	V_{OUT} to GND	--	--	10	nF
Output Load Capability	I_{Source}	V_{OUT} to V_{DD}	1.0	--	--	mA
	I_{Sink}	V_{OUT} to GND	1.5	--	--	mA
Output Voltage Range	$V_{OUT(H)}$	$T_A=25^\circ C, B=1000Gs$	4.8	4.9	4.99	V
	$V_{OUT(L)}$	$T_A=25^\circ C, B=-1000Gs$	0.01	0.1	0.2	V
Step Response Time	t_{RESP}	Delay the output signal reaching 90%	120	200	--	μS
Output Referred Noise ⁴	V_N	$T_A=25^\circ C,$ $Sens=16.0mV/Gs$	--	30	--	$mV_{(p-p)}$
Pre-Programming Target						
Pre-Programming Quiescent Voltage Output	$V_{OUT(Q)init}$	$T_A=25^\circ C, B=0 Gs$	--	2.5	--	V
Pre-Programming Sensitivity	$Sens_{init}$	$T_A=25^\circ C$	--	8.0	--	mV/Gs
Linearity Sensitivity Error	Lin_{ERR}		--	1.0	--	%

¹ On power-up, the output of the SC4616 will be held low until V_{DD} exceeds V_{UVLOHI} . Once powered, the output will remain valid until V_{DD} drops below V_{UVLOLO} when the output will be pulled low

² See Characteristic Definitions

³ f_C varies up to approximately 20% over the full operating ambient temperature range and process

⁴ Values is derived as 6 sigma value from the spectral noise density.

OPERATING CHARACTERISTICS(continued)

Quiescent Voltage Output programming						
Quiescent Voltage Output Range	$V_{OUT(Q)}$	B=0 Gs, $T_A=25^\circ\text{C}$	2.4	2.5	2.6	V
Quiescent Voltage Output Programming Bits			--	6	--	Bits
Average Quiescent Voltage Output Step Size	$\text{Step}_{V(Q)}$	$T_A=25^\circ\text{C}$	--	4	--	mV
Sensitivity Programming						
Sensitivity Range	Sens	$T_A=25^\circ\text{C}$	8.0		24	mV/Gs
Sensitivity Programming Bits				9		Bits
Average Sensitivity Step Size	Step_{SEN}	$T_A=25^\circ\text{C}$	--	40	--	$\mu\text{V/Gs}$
Drift Characteristics						
Quiescent Voltage Output Drift	$\Delta V_{OUT(Q)}$	Sens=10.0mV/Gs	--	20	40	mV
Sensitivity Drift	ΔSens	Sens=10.0mV/Gs	--	2	--	%

FUNCTION DESCRIPTION

Power-On Time: When the supply is ramped to its operating voltage, the device output requires a finite time to react to an input magnetic field. Power-On Time is defined as the time it takes for the output voltage to begin responding to an applied magnetic field after the power supply has reached its minimum specified operating voltage, V_{DD} (min).

Quiescent output voltage: In the quiescent state (that is, with no significant magnetic field: $B=0$),

Quiescent output voltage drift through temperature range: Due to internal component tolerances and thermal considerations, the quiescent voltage output may drift from its nominal value through the operating ambient temperature. For purposes of specification, the quiescent output voltage drift through temperature range, $\Delta V_{OUT(Q)}$ is defined as:

$$\Delta V_{OUT(Q)} = \Delta V_{OUT(Q)TA} - \Delta V_{OUT(Q)25^{\circ}C}$$

Sensitivity: The presence of a South polarity magnetic field perpendicular to the branded surface of the package increases the output voltage from its quiescent value toward the supply voltage rail. The amount of the output voltage increase is proportional to the magnitude of the magnetic field applied. Conversely, the application of a North polarity field will decrease the output voltage from its quiescent value. This proportionality is specified as the magnetic sensitivity, $Sens$ (mV/Gs), of the device and is defined as:

$$Sens = \frac{V_{OUT}(B+) - V_{OUT}(B-)}{B(+) - B(-)}$$

Where $B(+)$ and $B(-)$ are two magnetic fields with opposite polarities.

TYPICAL APPLICATION

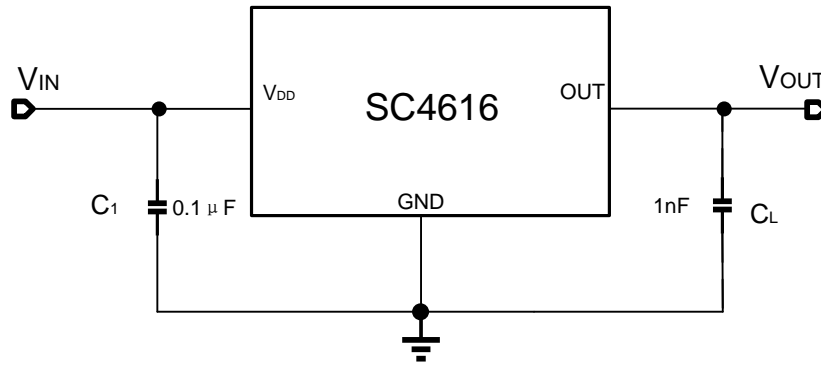

In the quiescent state (that is, with no significant magnetic field: $B=0$), the output, $V_{OUT(Q)}$, equals to half of the supply voltage, V_{DD} , throughout the entire operating range of V_{DD} . The presence of a South polarity magnetic field perpendicular to the branded surface of the package increases the output voltage from its quiescent value toward the supply voltage rail. The amount of the output voltage increase is proportional to the magnitude of the magnetic field applied. Conversely, the application of a North polarity field will decrease the output voltage from its quiescent value. This proportionality is specified as the magnetic sensitivity, $Sens$ (mV/Gs), of the device.

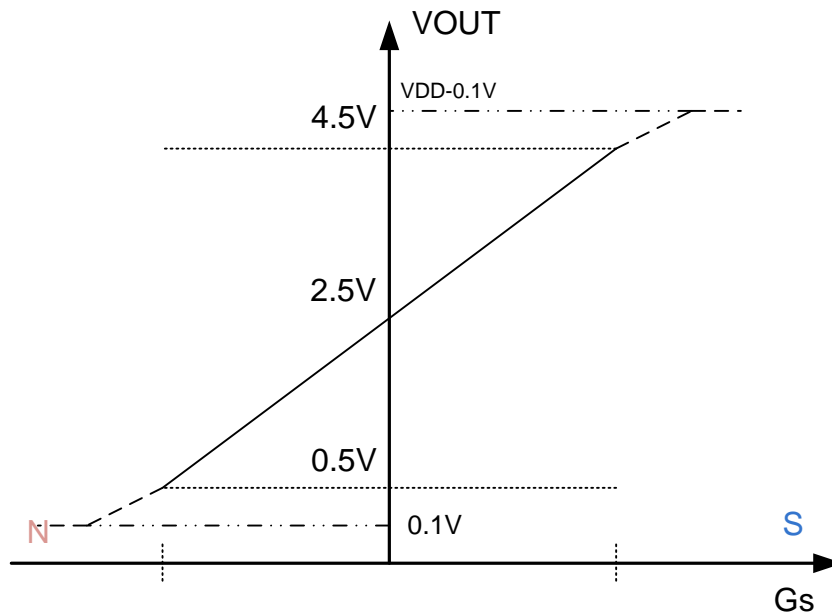

PACKAGE INFORMATION

**3-Terminal
UA Package**

Dimension: mm

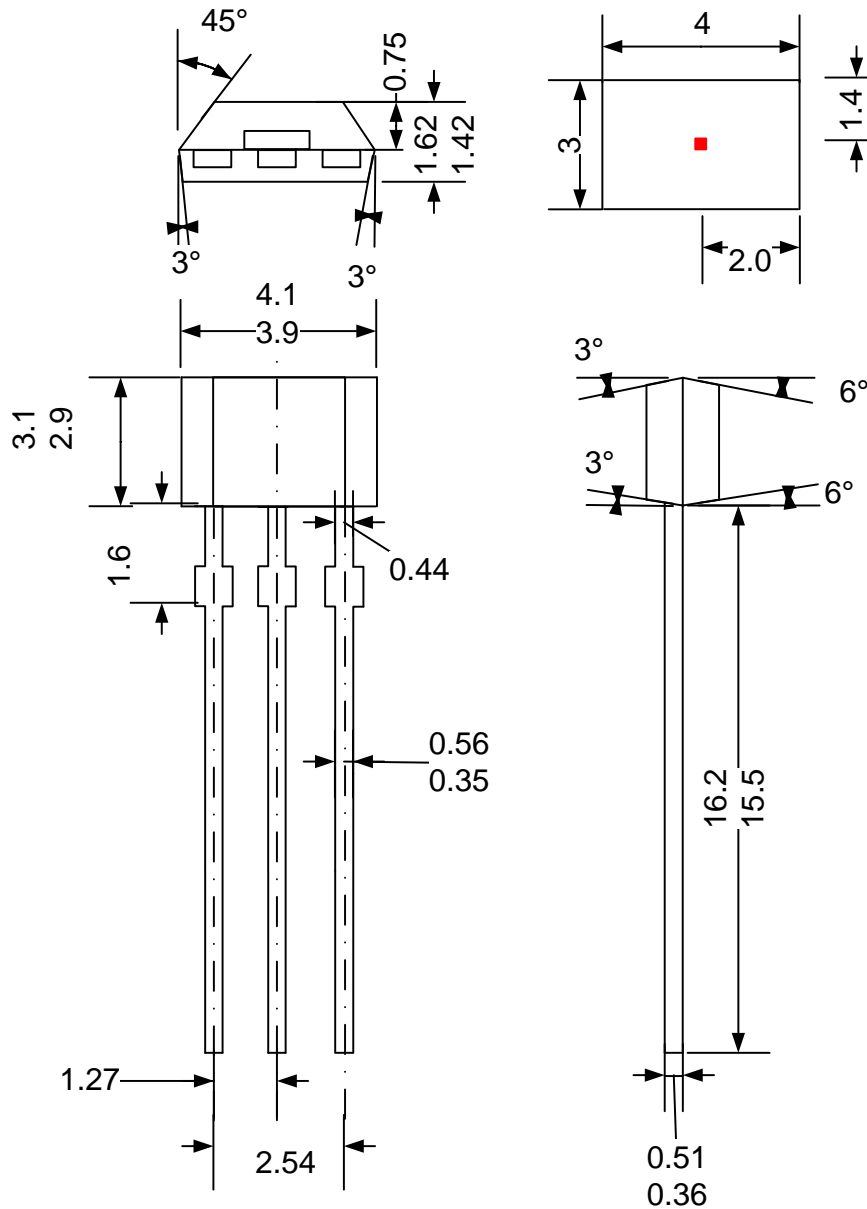

Notes:

1. Exact body and lead configuration at vendor's option within limits shown.
2. Height does not include mold gate flash.

Where no tolerance is specified, dimension is nominal.

REVISION HISTORY

Revision	Date	Description
Rev1.0	2017-08-14	Preliminary Datasheet
Rev2.0	2018-11-15	Perfect FEATURES
Rev2.3	2019-09-22	The final revision of old datasheet
RevA/1.0	2020-11-19	Unified datasheet format