

NOTES:

- 1) HOUSING MATERIAL:
BL - NYLON 6/6, U.L. 94V-2,
COLOR: BLACK.
 - TERMINAL MATERIAL: BRASS, ALLOY
 - 2) TERMINAL PLATING:
"BLANK" -.000100/(.00254) MIN. MATTE TIN OVER
.000050/(.00127) MIN. NICKEL.
 - 3) PRODUCT SPECIFICATION: SEE PS-5556-001
 - 4) PARTS ARE NOT DESIGNED FOR CURRENT SHARING.
 - 5) PART MATES WITH MINI-FIT JR. RECEPTACLE #5557.
 - 6) PART CONFORMS TO CLASS "B" REQUIREMENTS OF COSMETIC SPECIFICATION PS-45499-002.
 - 7) PART IS DESIGNED FOR USE WITH #4 OR M3 SELF TAPPING SCREWS.
 - 8) DISCOLORATION IN THE BANDOLIER CARRIER AREA OF THE PIN IS INHERENT TO THE PLATING PROCESS AND IS DUE TO THE MASKING EFFECT OF THE CARRIER. THIS DISCOLORATION IS IN A NON-FUNCTIONAL AREA OF THE PIN AND WILL NOT AFFECT THE PERFORMANCE OF THE HEADER ASSEMBLY.
 - 9) CONNECTORS ARE NOT TO BE MATED OR UNMATED WHILE CIRCUITS ARE ALIVE.
- FORMING MARKS ARE ACCEPTABLE.

CIRCUIT SIZE	DIM. "A"	DIM. "B"	DIM. "C"	DIM. "D"
2	—	.213 (5.40)	.354 (9.00)	.606 (15.40)
4	.165 (4.20)	.378 (9.60)	.520 (13.20)	.772 (19.60)
6	.331 (8.40)	.543 (13.80)	.685 (17.40)	.937 (23.80)
8	.496 (12.60)	.709 (18.00)	.850 (21.60)	1.102 (28.00)
10	.661 (16.80)	.874 (22.20)	1.016 (25.80)	1.268 (32.20)
12	.827 (21.00)	1.039 (26.40)	1.181 (30.00)	1.433 (36.40)
14	.992 (25.20)	1.205 (30.60)	1.346 (34.20)	1.598 (40.60)
16	1.157 (29.40)	1.370 (34.80)	1.512 (38.40)	1.764 (44.80)
18	1.323 (33.60)	1.535 (39.00)	1.677 (42.60)	1.929 (49.00)
20	1.488 (37.80)	1.701 (43.20)	1.843 (46.80)	2.094 (53.20)
22	1.654 (42.00)	1.866 (47.40)	2.008 (51.00)	2.260 (57.40)
24	1.819 (46.20)	2.031 (51.60)	2.173 (55.20)	2.425 (61.60)

LEGEND:

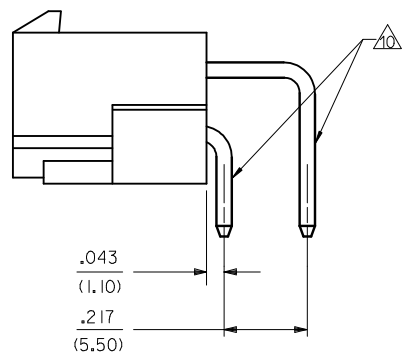
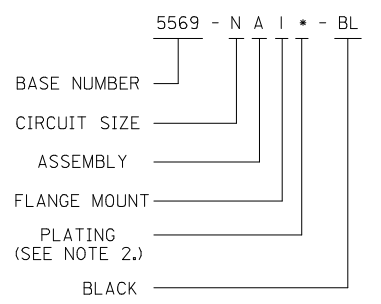

UPDATE NOTE 7 IEC NO: UCP2014-0298 DRWINGUYEN 2013/08/02 CHKD:JBELL 2013/08/02 APPR:FSMITH 2013/08/16	QUALITY SYMBOLS 	GENERAL TOLERANCES (UNLESS SPECIFIED)		DIMENSION STYLE IN/MM		SCALE 4:1	DESIGN UNITS METRIC	THIRD ANGLE PROJECTION	
		4 PLACES ± --- ± --- 3 PLACES ± --- ± .015 2 PLACES ± 0.38 ± --- 1 PLACE ± --- ± --- 0 PLACE ± ±	mm INCH DRAWN BY DATE R/JF 12/18/91 CHECKED BY DATE R/JF 12/18/91 APPROVED BY DATE FSMITH 2011/10/03	MINI-FIT JR RT. ANG. HDR ASSY WITH FLANGES, BLACK		molex		DOCUMENT NO. SDA-5569-NA1*-BL	
DRAFT WHERE APPLICABLE MUST REMAIN WITHIN DIMENSIONS		ANGULAR ±1/2°		SEE SHEET 2		THIS DRAWING CONTAINS INFORMATION THAT IS PROPRIETARY TO MOLEX. INCORPORATED AND SHOULD NOT BE USED WITHOUT WRITTEN PERMISSION			

