

Surface-Mount Device

SMD1210

RoHS 

Feature

- Resettable over current and over temperature protection
- Small size of 1210
- Small footprint
- Low resistance
- Fast time-to-trip
- RoHS compliant

Application

- Computer
- Battery
- Mobile phones
- Industrial controls
- Automotive
- Portable electronics
- Multimedia
- Game machines
- Telephony and broadband

Part Numbering



Product Dimensions in Millimeter

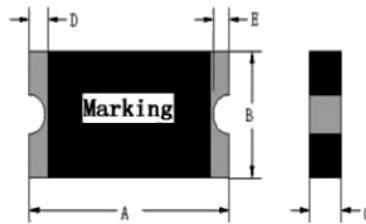

Part Number	A		B		C		D		E	
	Min	Max	Min	Max	Min	Max	Min	Max	Min	Max
SMD1210-150	--	3.50	--	2.85	--	0.8	0.25	--	0.10	--
SMD1210-175	--	3.50	--	2.85	--	0.8	0.25	--	0.10	--
SMD1210-190	--	3.50	--	2.85	--	0.8	0.25	--	0.10	--
SMD1210-200	--	3.50	--	2.85	--	0.8	0.25	--	0.10	--
SMD1210-210	--	3.50	--	2.85	--	0.8	0.25	--	0.10	--
SMD1210-230	--	3.50	--	2.85	--	0.8	0.25	--	0.10	--
SMD1210-250	--	3.50	--	2.85	--	0.8	0.25	--	0.10	--
SMD1210-260	--	3.50	--	2.85	--	0.8	0.25	--	0.10	--
SMD1210-300	--	3.50	--	2.85	--	0.8	0.25	--	0.10	--
SMD1210-350	--	3.50	--	2.85	--	1.0	0.25	--	0.10	--
SMD1210-380	--	3.50	--	2.85	--	1.0	0.25	--	0.10	--
SMD1210-400	--	3.50	--	2.85	--	1.0	0.25	--	0.10	--
SMD1210-450	--	3.50	--	2.85	--	1.0	0.25	--	0.10	--
SMD1210-500	--	3.50	--	2.85	--	1.0	0.25	--	0.10	--
SMD1210-550	--	3.50	--	2.85	--	1.2	0.25	--	0.10	--
SMD1210-600	--	3.50	--	2.85	--	1.2	0.25	--	0.10	--
SMD1210-650	--	3.50	--	2.85	--	1.3	0.25	--	0.10	--



Surface-Mount Device

SMD1210



SMD1210-700	--	3.50	--	2.85	--	1.3	0.25	--	0.10	--
SMD1210-750	--	3.50	--	2.85	--	1.3	0.25	--	0.10	--
SMD1210-800	--	3.50	--	2.85	--	1.3	0.25	--	0.10	--
SMD1210-850	--	3.50	--	2.85	--	1.4	0.25	--	0.10	--
SMD1210-900	--	3.50	--	2.85	--	1.4	0.25	--	0.10	--
SMD1210-950	--	3.50	--	2.85	--	1.4	0.25	--	0.10	--
SMD1210-1000	--	3.50	--	2.85	--	1.4	0.25	--	0.10	--
SMD1210-1050	--	3.50	--	2.85	--	1.6	0.25	--	0.10	--
SMD1210-1100	--	3.50	--	2.85	--	1.6	0.25	--	0.10	--
SMD1210-1150	--	3.50	--	2.85	--	1.6	0.25	--	0.10	--
SMD1210-1200	--	3.50	--	2.85	--	1.6	0.25	--	0.10	--

Electrical Characteristics

Part Number	I(A)		V _{max}	I _{max}	Pd _{typ}	T _{trip}		R _{min}	R _{1max}
	25°C		--	--	--	25°C		25°C	
	Hold	Trip	(V)	(A)	(W)	Current(A)	Time(S)	(Ω)	(Ω)
SMD1210-150	1.50	3.0	6.0	50	1.2	8.0	0.5	0.005	0.050
SMD1210-175	1.75	3.5	6.0	50	1.2	8.0	1.0	0.005	0.045
SMD1210-190	1.90	3.8	6.0	50	1.2	8.0	3.0	0.005	0.042
SMD1210-200	2.00	4.0	6.0	50	1.2	8.0	3.0	0.004	0.040
SMD1210-210	2.10	4.2	6.0	50	1.2	8.0	5.0	0.004	0.035
SMD1210-230	2.30	4.6	6.0	50	1.2	8.0	5.0	0.004	0.032
SMD1210-250	2.50	5.0	6.0	50	1.2	8.0	5.0	0.003	0.030
SMD1210-260	2.60	5.2	6.0	50	1.2	12.0	5.0	0.003	0.028
SMD1210-300	3.00	6.0	6.0	50	1.2	12.0	5.0	0.003	0.026
SMD1210-350	3.50	7.0	6.0	50	1.2	12.0	5.0	0.002	0.024
SMD1210-380	3.80	7.6	6.0	50	1.5	12.0	5.0	0.002	0.020
SMD1210-400	4.00	8.0	6.0	50	1.5	16.0	5.0	0.001	0.018
SMD1210-450	4.50	9.0	6.0	50	1.5	16.0	5.0	0.001	0.014
SMD1210-500	5.00	10.0	6.0	50	1.5	16.0	5.0	0.001	0.012
SMD1210-550	5.50	11.0	6.0	50	1.5	20.0	5.0	0.0008	0.010
SMD1210-600	6.00	12.0	6.0	50	1.5	20.0	5.0	0.0008	0.009
SMD1210-650	6.50	13.0	6.0	50	1.5	20.0	5.0	0.0005	0.008
SMD1210-700	7.00	14.0	6.0	50	1.6	20.0	5.0	0.0005	0.008
SMD1210-750	7.50	15.0	6.0	50	1.6	20.0	5.0	0.0005	0.007
SMD1210-800	8.00	16.0	6.0	50	1.6	20.0	5.0	0.0004	0.007
SMD1210-850	8.50	17.0	6.0	50	1.6	20.0	5.0	0.0004	0.006
SMD1210-900	9.00	18.0	6.0	50	1.6	30.0	5.0	0.0003	0.006
SMD1210-950	9.50	19.0	6.0	50	1.6	30.0	5.0	0.0002	0.006
SMD1210-1000	10.00	20.0	6.0	50	1.6	30.0	5.0	0.0002	0.005
SMD1210-1050	10.50	21.0	6.0	50	1.8	30.0	5.0	0.0002	0.005
SMD1210-1100	11.00	22.0	6.0	50	1.8	30.0	5.0	0.0001	0.0045
SMD1210-1150	11.5	23.0	6.0	50	1.8	30.0	5.0	0.0001	0.0045
SMD1210-1200	12.0	24.0	6.0	50	1.8	30.0	5.0	0.0001	0.004

I_H =Hold current: maximum current at which the device will not trip at 25°C still air reflow soldering of 260°C for 20 sec.
 I_T =Trip current: minimum current at which the device will always trip at 25°C still air reflow soldering of 260°C for 20 sec.
 V_{max} =Maximum continuous voltage device can withstand without damage at rated current
 I_{max} =Maximum fault current device can withstand without damage at rated voltage.
 T_{trip} =Maximum time to trip(s) at assigned current reflow soldering of 260°C for 20 sec.
 Pd_{typ} =Typical power dissipation: typical amount of power dissipated by the device when in state air environment.
 R_{min} = Minimum resistance of device in initial (un-soldered) state.
 R_{1max} =Maximum resistance of device at 25°C measured one hour after reflow soldering of 260°C for 20 sec.
Value specified is determined by using the PWB with 0.030" *1.5oz copper traces.

Caution: Operation beyond the specified rating may result in damage and possible arcing and flame.

Environmental Specifications

Test	Test Conditions	Accept /Reject Criteria
Recommended storage conditions	40°C max, 70% R.H. max	No change
Passive aging:	85°C, 1000 hours	$\leq R_{1max}$
Moisture Resistance	85% RH,85°C,1000hrs	$\leq R_{1max}$
Thermal Shock	MIL-STD-202 Method 107G +85°C /-40°C 20 times	$\leq R_{1max}$
Vibration	MIL-STD-883C, Method 2007.1, Condition A	No change
Solvent Resistance	MIL-STD-202, Method 215	No change
Moisture Level Sensitivity	Level 1, J-STD-020C	No change

Thermal Derating [Hold Current (A) at Ambient Temperature (°C)]

Part Number		Maximum Ambient Operating Temperature (°C)							
		-40	-20	0	25	40	50	60	70
SMD1210-150	I_{hold}	2.3	2.0	1.7	1.5	1.3	1.2	1.1	0.9
	I_{trip}	4.6	4.0	3.4	3.0	2.6	2.4	2.2	1.8
SMD1210-175	I_{hold}	2.6	2.3	2.0	1.75	1.5	1.3	1.2	1.1
	I_{trip}	5.2	4.6	4.0	3.5	3.0	2.6	2.4	2.2
SMD1210-190	I_{hold}	2.9	2.5	2.2	1.9	1.6	1.5	1.3	1.2
	I_{trip}	5.8	5.0	4.4	3.8	3.2	3.0	2.6	2.4
SMD1210-200	I_{hold}	3.0	2.7	2.3	2.0	1.7	1.5	1.4	1.2
	I_{trip}	6.0	5.4	4.6	4.0	3.4	3.0	2.8	2.4
SMD1210-210	I_{hold}	3.2	2.8	2.4	2.1	1.8	1.6	1.5	1.3
	I_{trip}	6.4	5.6	4.8	4.2	3.6	3.2	3.0	2.6
SMD1210-230	I_{hold}	3.5	3.1	2.7	2.3	2.0	1.8	1.6	1.4
	I_{trip}	7.0	6.2	5.4	4.6	4.0	3.6	3.2	2.8
SMD1210-250	I_{hold}	3.8	3.3	2.9	2.5	2.2	1.9	1.8	1.5
	I_{trip}	7.6	6.6	5.8	5.0	4.4	3.8	3.6	3.0
SMD1210-260	I_{hold}	3.9	3.5	3.0	2.6	2.2	2.0	1.9	1.6
	I_{trip}	7.8	7.0	6.0	5.2	4.4	4.0	3.8	3.2
SMD1210-300	I_{hold}	4.5	4.0	3.5	3.0	2.6	2.3	2.1	1.8
	I_{trip}	9.0	8.0	7.0	6.0	5.2	4.6	4.2	3.6



Surface-Mount Device

SMD1210



SMD1210-350	I _{hold}	5.3	4.7	4.1	3.5	3.0	2.7	2.5	2.1
	I _{trip}	10.6	9.4	8.2	7.0	6.0	5.4	5.0	4.2
SMD1210-380	I _{hold}	5.7	5.1	4.4	3.8	3.3	2.9	2.7	2.3
	I _{trip}	11.4	10.2	8.8	7.6	6.6	5.8	5.4	4.6
SMD1210-400	I _{hold}	6.0	5.3	4.6	4.0	3.4	3.1	2.8	2.4
	I _{trip}	12.0	10.6	9.2	8.0	6.8	6.2	5.6	4.8
SMD1210-450	I _{hold}	6.8	6.0	5.2	4.5	3.9	3.5	3.2	2.7
	I _{trip}	13.6	12.0	10.4	9.0	7.8	7.0	6.4	5.4
SMD1210-500	I _{hold}	7.5	6.7	5.8	5.0	4.3	3.9	3.5	3.1
	I _{trip}	15.0	13.4	11.6	10.0	8.6	7.6	7.0	6.2
SMD1210-550	I _{hold}	8.3	7.3	6.4	5.5	4.7	4.2	3.9	3.4
	I _{trip}	16.6	14.6	12.8	11.0	9.4	8.4	7.6	6.8
SMD1210-600	I _{hold}	9.0	8.0	7.0	6.0	5.2	4.6	4.2	3.7
	I _{trip}	18.0	16.0	14.0	12.0	10.4	9.2	8.4	7.6
SMD1210-650	I _{hold}	9.8	8.6	7.5	6.5	5.6	5.0	4.6	4.0
	I _{trip}	19.6	17.2	15.0	13.0	11.2	10.0	9.2	8.0
SMD1210-700	I _{hold}	11.3	9.8	8.3	7.0	6.4	5.3	4.9	4.5
	I _{trip}	22.6	19.6	16.6	14.0	12.8	10.6	9.8	9.0
SMD1210-750	I _{hold}	12.0	10.4	8.8	7.5	7.2	5.6	5.2	4.8
	I _{trip}	24.0	20.8	17.6	15.0	14.4	11.2	10.4	9.6
SMD1210-800	I _{hold}	12.8	11.1	9.4	8.0	7.5	6.0	5.5	5.1
	I _{trip}	25.6	22.2	18.8	16.0	15.0	12.0	11.0	10.2
SMD1210-850	I _{hold}	13.5	11.7	9.9	8.5	8.1	6.3	5.9	5.4
	I _{trip}	27.0	23.4	19.8	17.0	16.2	12.6	11.8	10.8
SMD1210-900	I _{hold}	14.3	12.4	10.5	9.0	8.6	6.7	6.2	5.7
	I _{trip}	28.6	24.8	21.0	18.0	17.6	13.4	12.4	11.4
SMD1210-950	I _{hold}	15.0	13.0	11.0	9.5	9.0	7.0	6.5	6.0
	I _{trip}	30.0	26.0	22.0	19.0	18.0	14.0	13.0	12.0
SMD1210-1000	I _{hold}	15.8	13.7	11.6	10.0	9.5	7.4	6.8	6.3
	I _{trip}	31.6	27.4	23.2	20.0	19.0	14.8	13.6	12.6
SMD1210-1050	I _{hold}	16.5	14.3	12.1	10.5	9.9	7.7	7.2	6.6
	I _{trip}	31.0	28.6	24.2	21.0	19.8	15.4	14.4	13.2
SMD1210-1100	I _{hold}	17.3	15.0	12.7	11.0	10.4	8.1	7.5	6.9
	I _{trip}	34.6	30.0	25.4	22.0	20.8	16.2	15.0	13.8
SMD1210-1150	I _{hold}	18.0	15.6	13.2	11.5	10.8	8.4	7.8	7.2
	I _{trip}	36.0	31.2	26.4	23.0	21.6	16.8	15.6	14.4
SMD1210-1200	I _{hold}	18.8	16.3	13.8	12.0	11.3	8.8	8.1	7.5
	I _{trip}	37.6	32.6	27.6	24.0	22.6	17.6	16.2	15.0

Surface-Mount Device

SMD1210



- A=SMD1210-150
- B=SMD1210-175
- C=SMD1210-190
- D=SMD1210-200
- E=SMD1210-210
- F=SMD1210-230
- G=SMD1210-250
- H=SMD1210-260
- I=SMD1210-300
- J=SMD1210-350
- K=SMD1210-380
- L=SMD1210-400
- M=SMD1210-450
- N=SMD1210-500
- O=SMD1210-550
- P=SMD1210-600
- Q=SMD1210-650
- R=SMD1210-700
- S=SMD1210-750
- T=SMD1210-800
- U=SMD1210-850
- V=SMD1210-900
- W=SMD1210-950
- X=SMD1210-1000
- Y=SMD1210-1050
- Z=SMD1210-1100
- AA=SMD1210-1150
- AB=SMD1210-1200

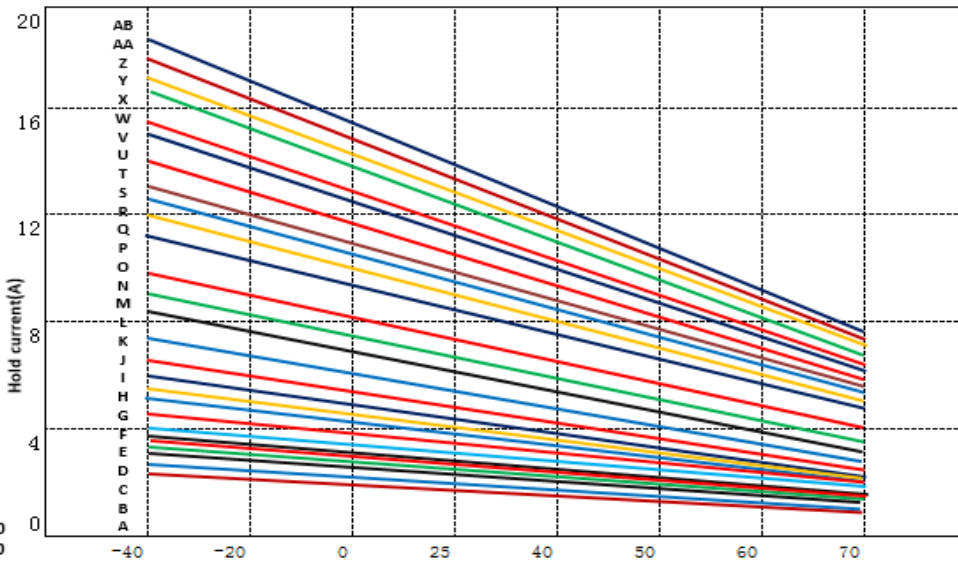

Solder Reflow Recommendation

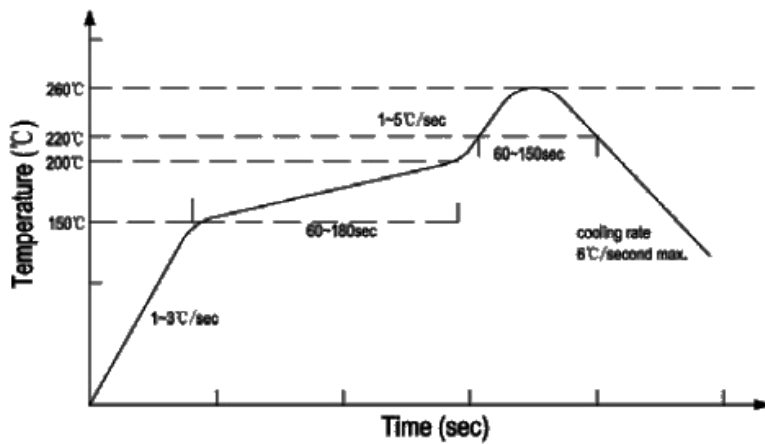

Reflow -curve

Recommended reflow methods: IR, hot air oven, nitrogen oven
 Devices can be cleaned using standard industry methods and solvents.

NOTE:

If reflow temperatures exceed the recommended profile, devices may not meet the performance requirements.

Caution: Operation beyond the rated voltage or current may result in rupture electrical arcing or flame

Packaging Quantity and Marking

Recommended Pad Layout (mm.)

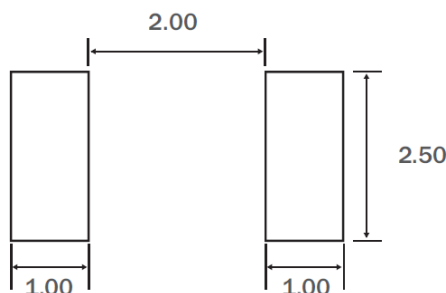

Device	Marking	Standard Quantity (pcs)
SMD1210-150	B 150	4000
SMD1210-175	B 175	4000
SMD1210-190	B 190	4000
SMD1210-200	B 200	4000
SMD1210-210	B 210	4000
SMD1210-230	B 230	4000
SMD1210-250	B 250	4000
SMD1210-260	B 260	4000
SMD1210-300	B 300	4000
SMD1210-350	B 350	4000
SMD1210-380	B 380	4000
SMD1210-400	B 400	4000
SMD1210-450	B 450	4000
SMD1210-500	B 500	4000
SMD1210-550	B 550	4000
SMD1210-600	B 600	4000
SMD1210-650	B 650	3000
SMD1210-700	B 700	3000
SMD1210-750	B 750	3000
SMD1210-800	B 800	3000
SMD1210-850	B 850	3000
SMD1210-900	B 900	3000
SMD1210-950	B 950	3000
SMD1210-1000	B 1000	3000
SMD1210-1050	B 1050	3000
SMD1210-1100	B 1100	3000
SMD1210-1150	B 1150	3000
SMD1210-1200	B 1200	3000

Tape Specifications:EIA-481-1(mm)

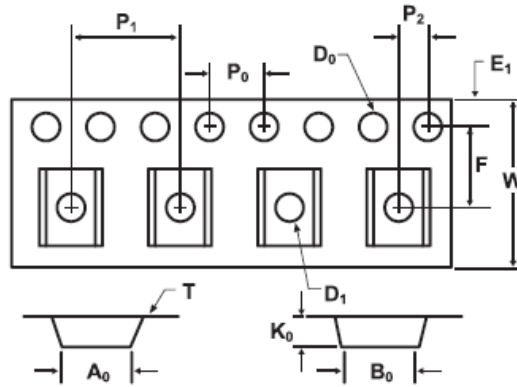

Governing Specifications	SMD1210-150~ SMD1210-380	SMD1210-400~ SMD1210-600	SMD1210-650~ SMD1210-1200
W	8.0±0.3	8.0±0.3	8.0±0.3
F	3.5±0.05	3.5±0.05	3.5±0.05
E1	1.75±0.1	1.75±0.1	1.75±0.1
D0	1.55±0.05	1.55±0.05	1.55±0.05
D1	1.0±0.1	1.0±0.1	1.0±0.1
P0	4.0±0.1	4.0±0.1	4.0±0.1
P1	4.0±0.1	4.0±0.1	4.0±0.1
P2	2.0±0.05	2.0±0.05	2.0±0.05
A0	2.9±0.1	2.9±0.1	2.9±0.1
B0	3.65±0.1	3.65±0.1	3.65±0.1
T	0.2±0.1	0.2±0.1	0.2±0.1
K0	0.74±0.1	1.04±0.1	1.35±0.1
Leader min	390	390	390
Trailer min	160	160	160

Reel Dimensions:EIA-481-1(mm)

Governing Specifications	EIA481-1
C	$\Phi 178 \pm 1.0$
D	$\Phi 60.2 \pm 0.5$
H	11.0 ± 0.5
W	9.0 ± 1.5

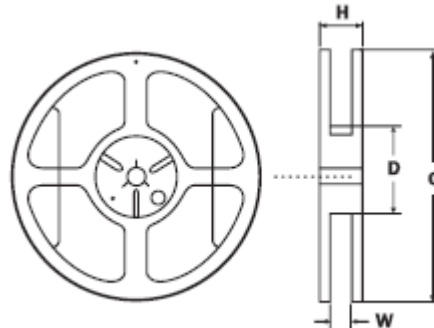

NOTE:

BNstar Co.,Ltd. makes no representations or warranties with respect to the accuracy or completeness of the contents of this publication and reserves the right to make changes to specifications and product descriptions at any time without notice. The products described in this document are not designed, intended, authorized or warranted for use as components in systems intended for surgical implant into the body, or in other applications intended to support or sustain life, or where malfunction of

BNstar's product may result in direct physical harm, injury, or death to a person or severe property or environmental damage. BNstar Co.,Ltd., reserves the right to discontinue or make changes to its products at any time without notice.

Website: <http://www.bnstar.net>

For additional information, please contact your local Sales Representative.

©Copyright 2006, BNstar Co.,Ltd.

 **CAUTION:**

Operation beyond the maximum ratings or improper use may result in device damage and possible electrical arcing and flame. The devices are intended for protection against occasional over-current or over temperature fault conditions and should not be used when repeated fault conditions or prolonged trip events are anticipated. Device performance can be impacted negatively if devices are handled in a manner inconsistent with recommended electronic, thermal, and mechanical procedures for electronic components.

Contact information

BNSTAR NEW MATERIALS CO., LTD.
 130Meilong Road Shanghai, P.R.China
 Tel:86-021-64251576 Fax: 86-021-64250020
 EMAIL: info@bnstar.net

Rev. letter		Date	
Design	Check	Audit	Approve