

General Description

The MIC5504 is a low-I_q low dropout linear regulator with 300mA driving current. The MIC5504 shows good power dissipation with <0.1uA shutdown current and 2uA quiescent current of light load for portable devices. The MIC5504 provides 0.8~3.6V output voltage for multiple application and it is with build-in thermal shutdown and current limit protection functions.

Features

- 2uA quiescent current at light load ±2% output voltage accuracy
- <0.1uA shutdown current
- 1.5~5.5V input range
- 0.8~3.6V output range
- Thermal shutdown protection
- Current limit protection
- RoHS Compliant and Halogen Free

Applications

- Cellular and smart phone Audio/Video equipment
- Battery-power equipment
- Portable electric devices

Ordering Information

MIC5504-x.xYMx-TR

	Definition	Symbol	Description
x.x	Output Voltage	08	VOUT = 0.8V
		10	VOUT = 1.0V
		12	VOUT = 1.2V
		15	VOUT = 1.5V
		18	VOUT = 1.8V
		25	VOUT = 2.5V
		28	VOUT = 2.8V
		30	VOUT = 3.0V
		33	VOUT = 3.3V
		36	VOUT = 3.6V
Y	Green	Y	Green for Hg/Pb free
Mx	Package type	M5	SOT23-5
		MT	DFN1*1

Pin Configuration

SOT23-5 Package

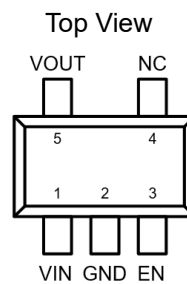

DFN1*1 Package

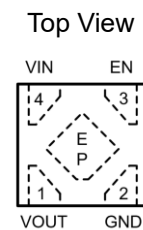

Pin Description

Pin No		Pin Name	Pin Description
SOT23-5	DFN1*1		
1	4	VIN	Input of the regulator.
2	2	GND	Ground.
3	3	EN	Enable control input, Active High.
4	--	NC	No Internal Connection.
5	1	VOUT	Output of the regulator.
--	EP	Exposed Pad	The exposed pad should be connected to a large ground plane to maximize thermal performance.

Functional Block Diagram

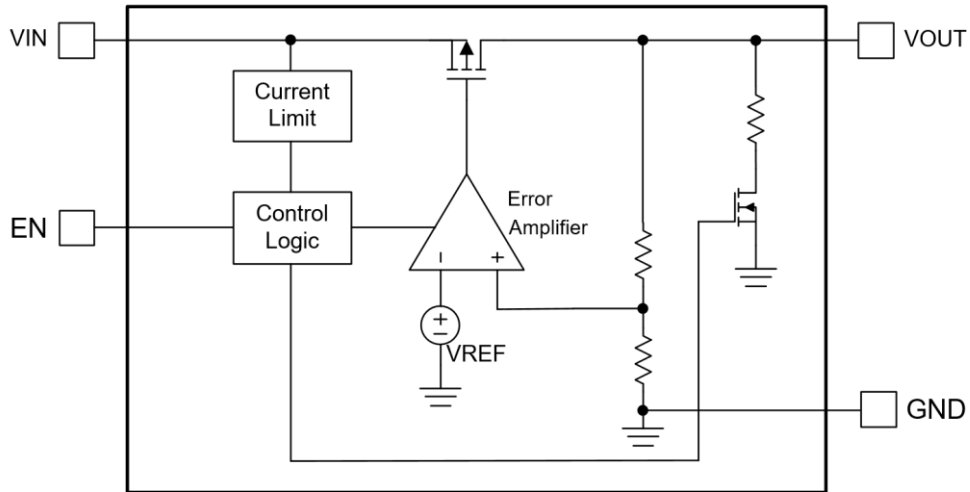

Typical Application Circuit

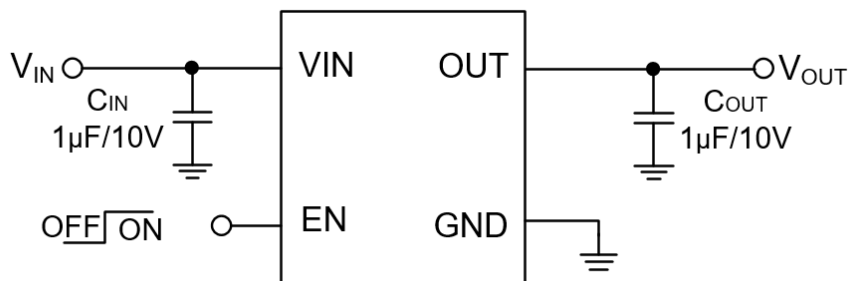

Absolute Maximum Ratings (Note 1)

VIN -----	-0.3V to 6.0V
VOUT -----	-0.3V to 6.0V
EN -----	-0.3V to 6.0V
VOUT to VIN -----	-6V to 0.3V
Power Dissipation, PD @ T _A = 25°C	
SOT23-5 -----	0.4W
DFN1*1 -----	0.4W
Package Thermal Resistance	
SOT23-5, θ _{JA} -----	250°C/W
DFN1*1, θ _{JA} -----	250°C/W
Lead Temperature (Soldering, 10 sec.) -----	260°C
Junction Temperature -----	150°C
Storage Temperature Range -----	-55°C to 150°C
ESD Susceptibility	
HBM (Human Body Model) -----	2kV
CDM (Charged Device Model) -----	200V

Recommended Operating Conditions

VIN -----	1.5V to 5.5V
Junction Temperature Range -----	-40°C to 85°C

Electrical Characteristics

VIN = EN = 5V, CIN=1μF, COUT=1μF, TA=25°C, unless otherwise noted.

Parameter	Symbol	Test Conditions	Min	Typ	Max	Unit
Input Voltage	VIN		1.5		5.5	V
Output Voltage Accuracy	VOUT	VIN=VOUT+1V, IOUT=10mA	-2		+2	%
VIN Shut Down Current	ISD	EN=0V			0.1	μA
VIN Quiescent Current	IQ	VIN > VOUT, EN=VIN, no load		0.8	2	μA
Current Limit	ILIMIT	VIN=5V, Load = VOUT*90%		500		mA
Short Current	ISC	VOUT=0V		150		mA
Dropout Voltage (Note 2)	VDROP	VOUT=3.3V, IOUT=200mA		180		mV
		VOUT=2.8V, IOUT=200mA		200		
		VOUT=1.8V, IOUT=200mA		280		
		VOUT=1.2V, IOUT=200mA		420		
Line Regulation	ΔVLINE	VIN=VOUT+0.5V to 5.5V IOUT=20mA		5		mV
Load Regulation	ΔVLOAD	IOUT=1mA to 300mA		20		mV
Enable High Voltage	VENH		1.5			V
Enable Low Voltage	VENL				0.4	V
Power Supply Rejection Rate	PSRR	f=100Hz and IOUT=10mA		66		dB
		f=1kHz and IOUT=10mA		50		
Output Noise Voltage	ENO	10Hz to 100kHz and COUT=1μF		80		μVRMS
Output Discharge Resistance	Rdischg			60		Ω
Thermal Shutdown Threshold	TSD			165		°C
Thermal Shutdown Hysteresis	ΔTSD			20		°C

Note 1. Stresses beyond those listed “Absolute Maximum Ratings” may cause permanent damage to the device. These are stress ratings only, and functional operation of the device at these or any other conditions beyond those indicated in the operational sections of the specifications is not implied. Exposure to absolute maximum rating conditions may affect device reliability.

Note 2. The dropout voltage is defined as VIN – VOUT, when VOUT is 95% of the normal value of VOUT.

Typical Operating Characteristics

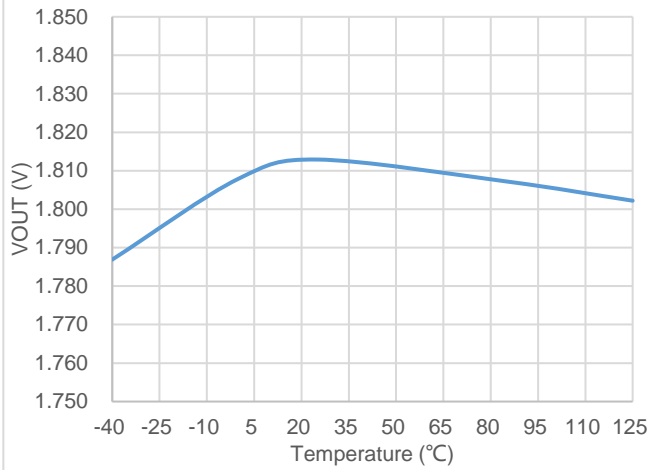

Output Voltage vs Temperature
VIN = 2.8V, VOUT = 1.8V, IOUT = 20mA

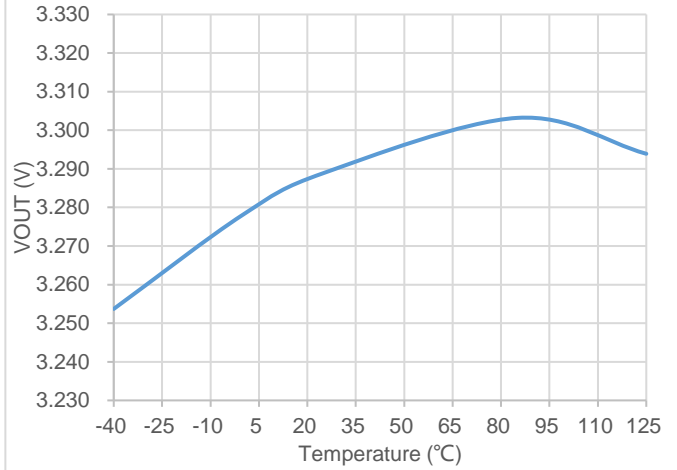

Output Voltage vs Temperature
VIN = 4.3V, VOUT = 3.3V, IOUT = 20mA

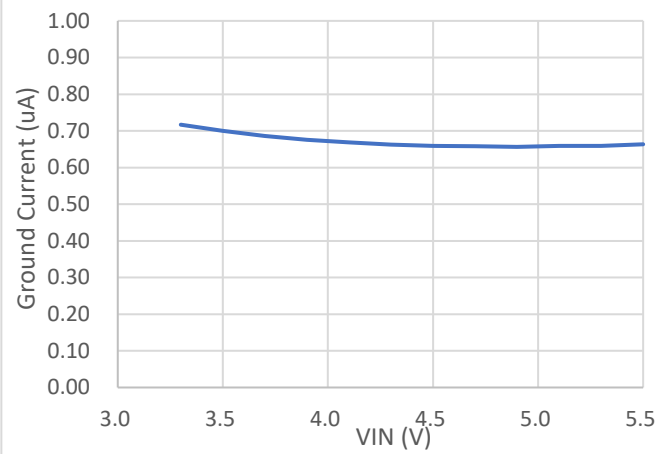

Ground Current vs Input Voltage
VOUT = 2.8V, no load

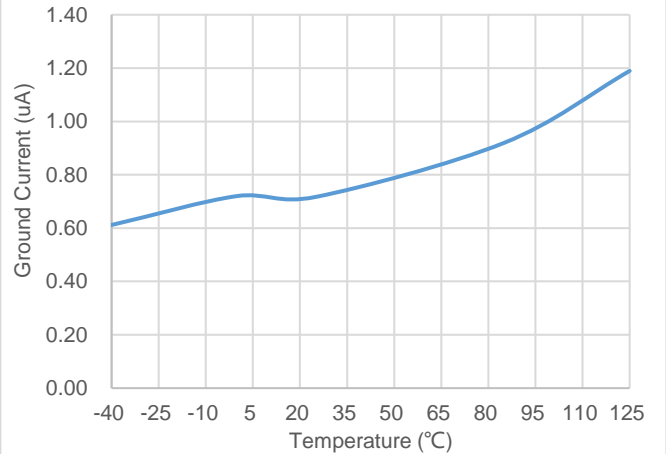

Ground Current vs Temperature
VIN = 3.3V, VOUT = 2.8V, no load

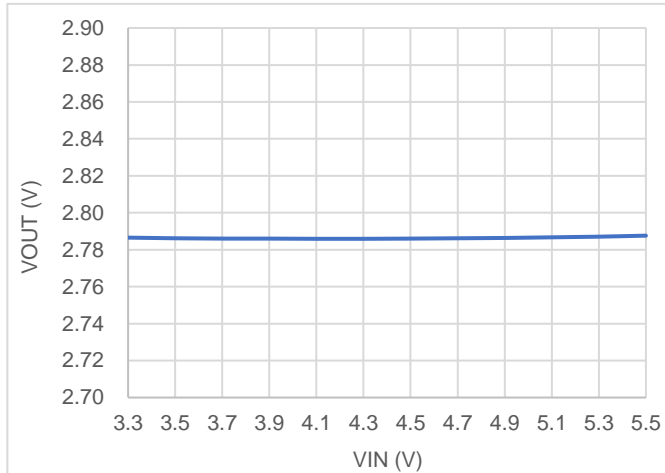

Output Voltage vs Input Voltage
VOUT = 2.8V, IOUT = 20mA

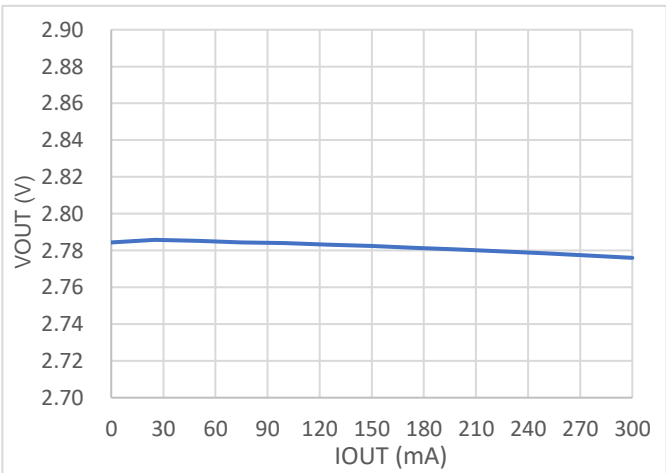

Output Voltage vs Output Current
VIN = 3.6V, VOUT = 2.8V

Typical Operating Characteristics(continued)

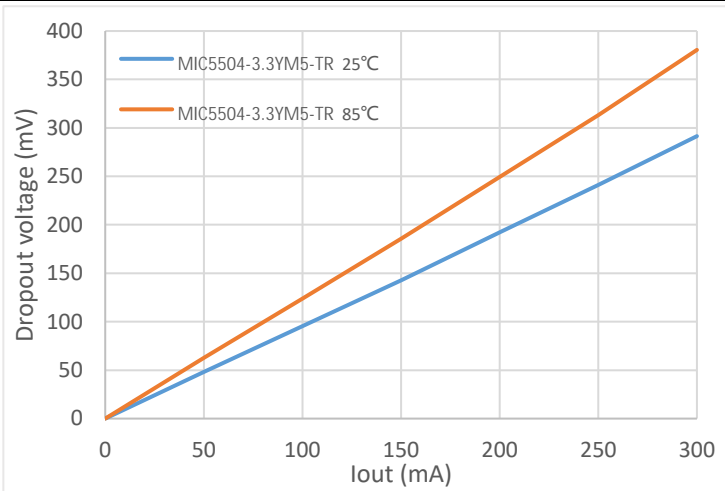

Dropout Voltage vs Output Current
VOUT = 3.3V

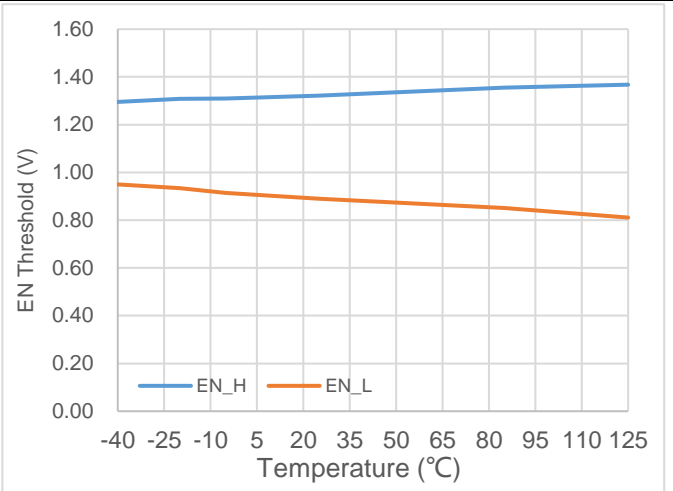

EN Threshold vs Temperature
VIN = 3.3V, VOUT = 2.8V

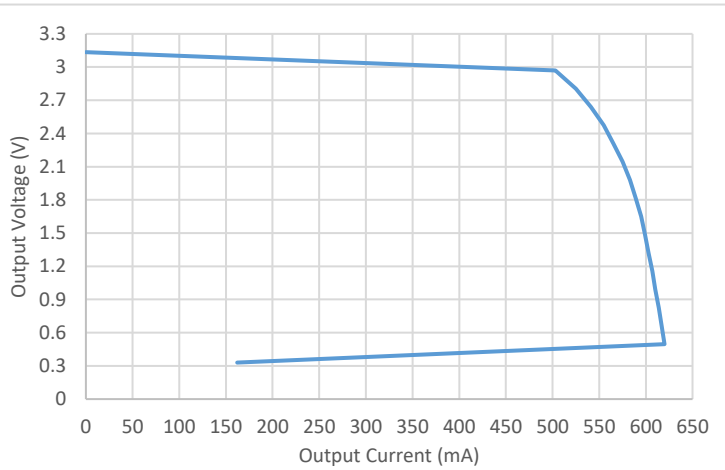

Output Voltage VS Output Current
VIN = 5V, VOUT = 3.3V

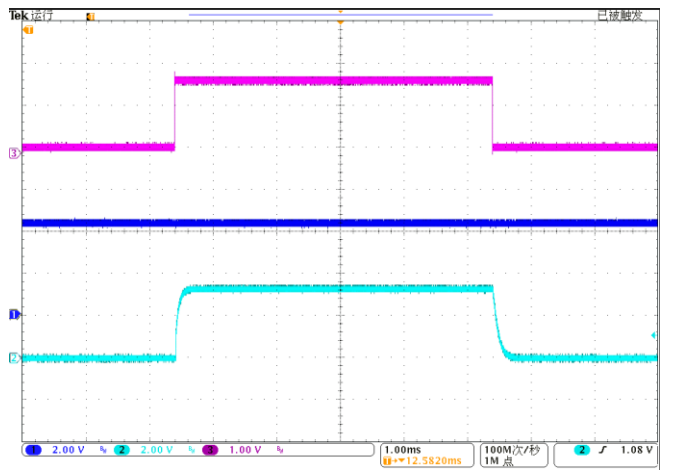

ON/OFF by EN (CH1 = VIN, CH2 = VOUT, CH3=EN)
VIN = 4.3V, VOUT = 3.3V

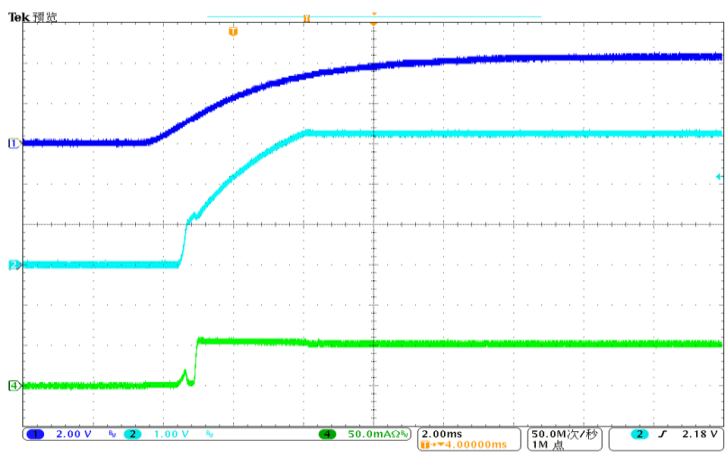

Power ON (CH1 = VIN, CH2 = VOUT, CH3 = IOUT)
VIN = EN, VOUT = 3.3V, IOUT = 50mA

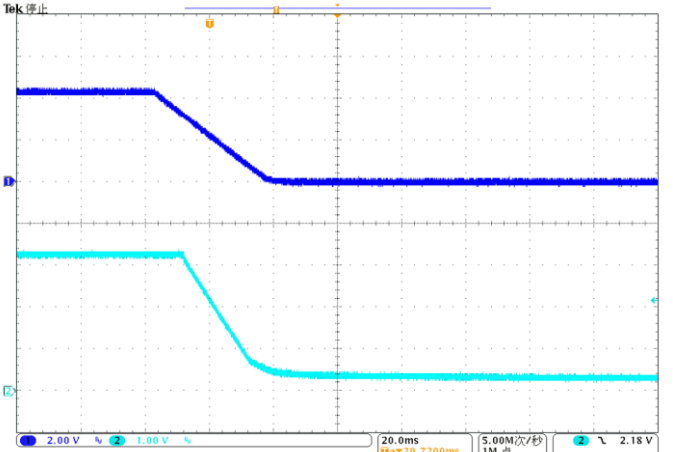

Power OFF (CH1 = VIN, CH2 = VOUT)
VIN = EN, VOUT = 3.3V

Typical Operating Characteristics(continued)

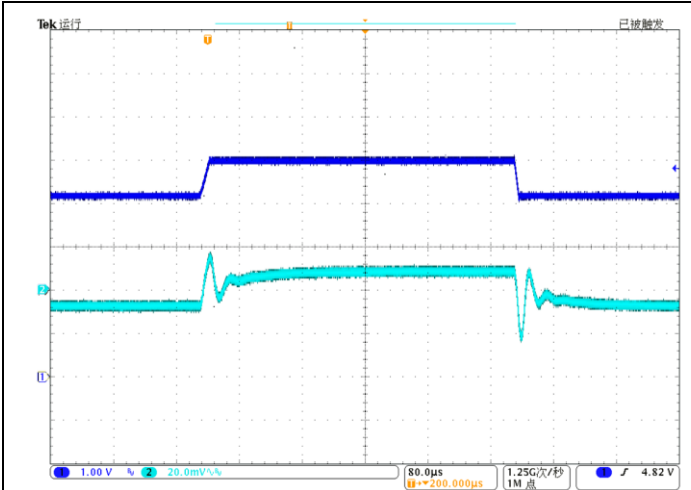

Line Transient (CH1 = VIN, CH2 = VOUT)
VIN = 4.0V to 5V, VOUT = 3.3V, IOUT = 10mA

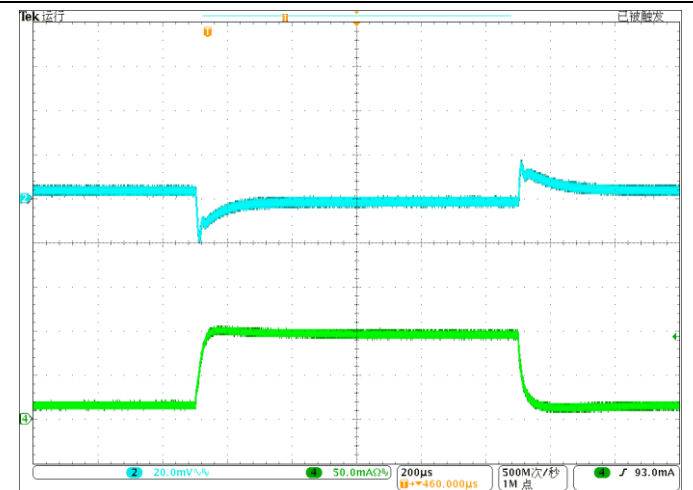

Load Transient (CH2 = VOUT, CH4 = IOUT)
VIN = 4.3V, VOUT = 3.3V, IOUT = 10mA ~ 100mA

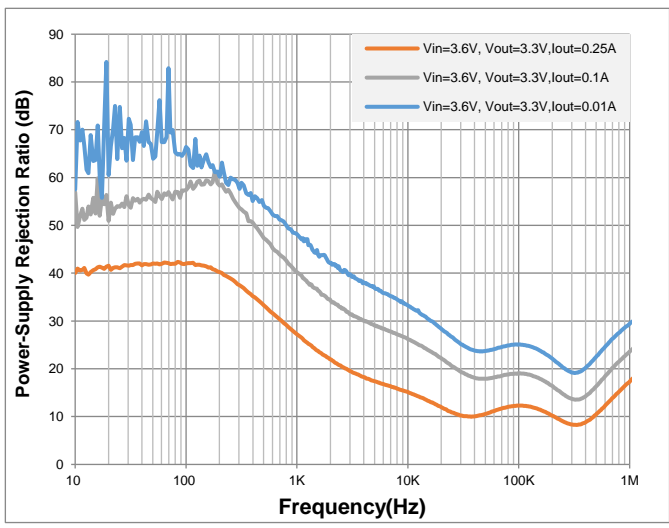

PSRR vs Frequency

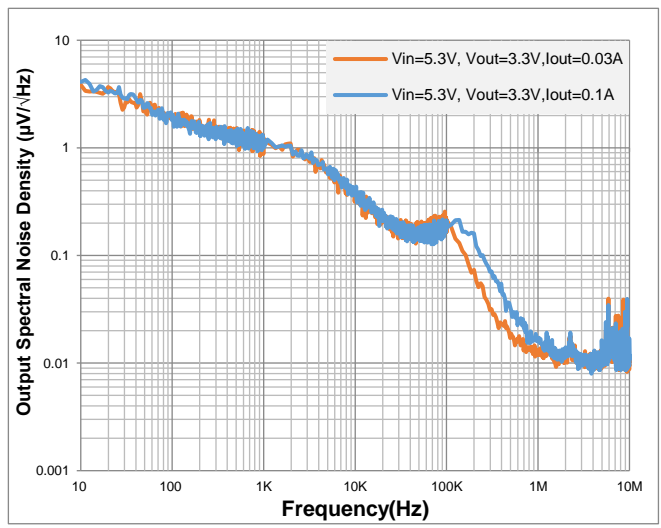

Noise Density Spectrum

Application Information

Input and Output Capacitor Requirements

The external input and output capacitors of MIC5504 series must be properly selected for stability and performance. Use a 1 μ F or larger input capacitor and place it close to the IC's VIN and GND pins. Any output capacitor meeting the minimum 1m Ω ESR (Equivalent Series Resistance) and effective capacitance between 1 μ F and 22 μ F requirement may be used. Place the output capacitor close to the IC's VOUT and GND pins. Increasing capacitance and decreasing ESR can improve the circuit's PSRR and line transient response.

Enable Function

The MIC5504 series has an EN pin to turn on or turn off the regulator. When the EN pin is in logic high, the regulator will be turned on. When the EN pin is in logic low, the shutdown current is almost 0 μ A typical. The EN pin may be directly tied to VIN to keep the part on.

Current Limit

The MIC5504 series contain the current limiter of output power transistor, which monitors and controls the transistor, limiting the output current to 500mA (typical). The output can be shorted to ground indefinitely without damaging the part.

Auto Discharge Function

The MIC5504 series can discharge the output capacitor. When the VIN ready and EN pin is in logic low, the internal NMOS between VOUT and GND will be turned on. The discharge resistance (Rdischg) is 60 Ω (at VIN=5V, typical).

Dropout Voltage

The MIC5504 series use a PMOS pass transistor to achieve low dropout. When (VIN – VOUT) is less than the dropout voltage (V_{DROP}), the PMOS pass device is in the linear region of operation and the input-to-output resistance is the R_{DS(ON)} of the PMOS pass element. V_{DROP} scales approximately with the output current because the PMOS device behaves as a resistor in dropout condition.

As any linear regulator, PSRR and transient response are degraded as (VIN – VOUT) approaches dropout condition.

OTP (Over Temperature Protection)

The over temperature protection function of MIC5504 series will turn off the P-MOSFET when the junction temperature exceeds 165°C (typical). Once the junction temperature cools down by approximately 20°C, the regulator will automatically resume operation.

Thermal Considerations

For continuous operation, do not exceed the absolute maximum junction temperature. The maximum power dissipation depends on the thermal resistance of the IC package, PCB layout, rate of surrounding airflow, and difference between junction and ambient temperature. The maximum power dissipation can be calculated as below:

$$PD(\text{Max}) = (125^{\circ}\text{C} - 25^{\circ}\text{C}) / (250^{\circ}\text{C}/\text{W}) = 0.4\text{W}$$

For SOT-23-5 / DFN1*1 packages.

$$PD(\text{Max}) = (125^{\circ}\text{C} - 25^{\circ}\text{C}) / (330^{\circ}\text{C}/\text{W}) = 0.3\text{W}$$

For SOT23-3 package.

Power dissipation (PD) is equal to the product of the output current and the voltage drop across the output pass element, as shown in the equation below:

$$PD = (V_{IN} - V_{OUT}) \times I_{OUT}$$

Layout Consideration

By placing input and output capacitors on the same side of the PCB as the LDO, and placing them as close as is practical to the package can achieve the best performance. The ground connections for input and output capacitors must be back to the MIC5504 ground pin using as wide and as short of a copper trace as is practical.

Connections using long trace lengths, narrow trace widths, and/or connections through via must be avoided. These add parasitic inductances and resistance that results in worse performance especially during transient conditions.

Outline Dimension

SOT23-5 Package

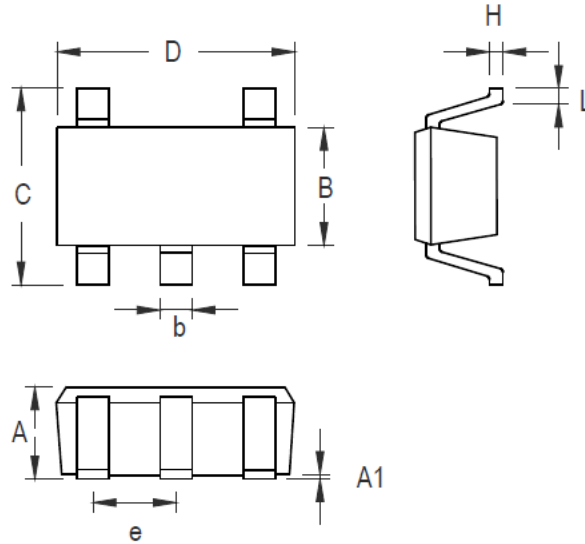

Symbol	Dimensions In Millimeters		Dimensions In Inches	
	Min	Max	Min	Max
A	0.889	1.295	0.035	0.051
A1	0.000	0.152	0.000	0.006
B	1.397	1.803	0.055	0.071
b	0.356	0.559	0.014	0.022
C	2.591	2.997	0.102	0.118
D	2.692	3.099	0.106	0.122
e	0.838	1.041	0.033	0.041
H	0.080	0.254	0.003	0.010
L	0.300	0.610	0.012	0.024

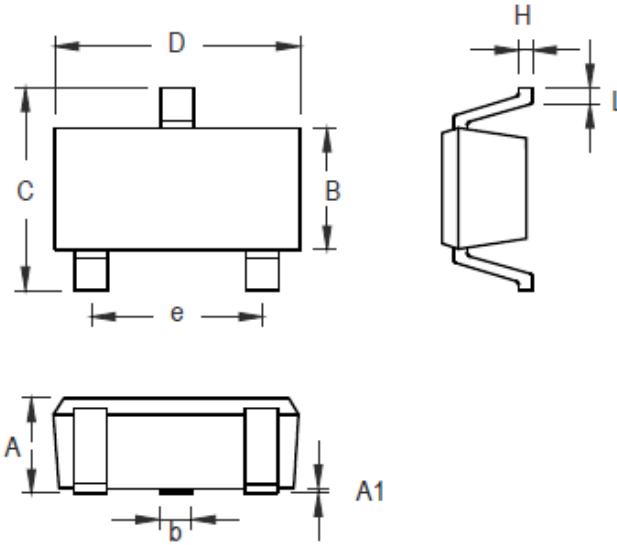

Symbol	Dimensions In Millimeters		Dimensions In Inches	
	Min	Max	Min	Max
A	0.889	1.295	0.035	0.051
A1	0.000	0.152	0.000	0.006
B	1.397	1.803	0.055	0.071
b	0.356	0.508	0.014	0.020
C	2.591	2.997	0.102	0.118
D	2.692	3.099	0.106	0.122
e	1.803	2.007	0.071	0.079
H	0.080	0.254	0.003	0.010
L	0.300	0.610	0.012	0.024

DFN1*1 Package

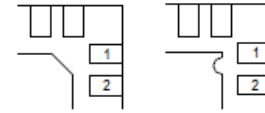
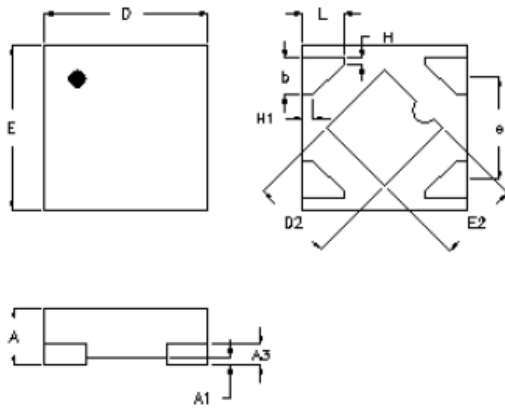

DETAIL A

Pin #1 ID and Tie Bar Mark Options

Note : The configuration of the Pin #1 identifier is optional, but must be located within the zone indicated.

Symbol	Dimensions In Millimeters		Dimensions In Inches	
	Min.	Max.	Min.	Max.
A	0.300	0.400	0.012	0.016
A1	0.000	0.050	0.000	0.002
A3	0.117	0.162	0.005	0.006
b	0.175	0.275	0.007	0.011
D	0.900	1.100	0.035	0.043
D2	0.450	0.550	0.018	0.022
E	0.900	1.100	0.035	0.043
E2	0.450	0.550	0.018	0.022
e	0.625		0.025	
L	0.200	0.300	0.008	0.012
H	0.039		0.002	
H1	0.064		0.003	