

# LD35SB10 Thru LD35SB160

## High Current Glass Passivated Molding Single-Phase Bridge Rectifier

Reverse Voltage 100 to 1600V Forward Current 35 A

### FEATURES

- Plastic Package has Underwriters Laboratory Flammability Classification 94V-0
- High current capacity with small package
- Glass passivated chip junctions
- ESD HBM Classification 3A
- Superior thermal conductivity
- High IFSM

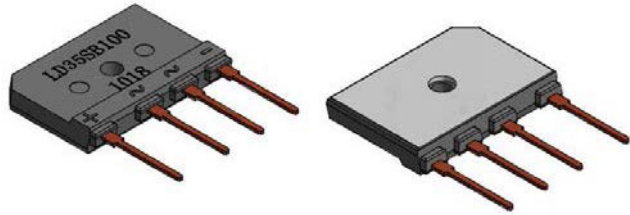

### 1. Maximum & Thermal Characteristics Ratings at 25°C ambient temperature unless otherwise specified.

Parameter Symbol	Symbol	LD35S B10	LD35S B20	LD535 SB40	LD35S B60	LD35S B80	LD35SB 100	LD35SB 120	LD35SB 160	Unit
Maximum repetitive voltage	VRRM	100	200	400	600	800	1000	1200	1600	V
Maximum RMS Voltage	VRMS	70	140	280	420	560	700	840	1120	V
Maximum DC Blocking Voltage	VDC	100	200	400	600	800	1000	1200	1600	V
Maximum DC reverse current TA=25 °C	IR	10								μA
at rated DC blocking voltage TA=125°C		500								
Maximum average forward rectified output current at	With heatsink Tc=100°C <sup>(1)</sup>	35								A
	Without heatsink Ta=25°C <sup>(2)</sup>	10								A
Peak forward surge current 8.3ms single half sine-wave superimposed on rated load	IFSM	400								A
Rating of fusing (t<8.3ms)	I <sup>2</sup> t	660								A2sec
Dielectric strength terminals to case, AC 1 minute Current 1mA	Vdia	2.5								KV
Max instantaneous forward voltage at 17.5A	VF	1.05								V
Operating junction temperature	TJ	-55~150								°C
Maximum thermal on P.C.B. without heat-sink	R <sub>θJA</sub>	15								°C/W
resistance per leg on Al plate heat-sink <sup>(3)</sup>	R <sub>θJC</sub>	0.75								
Storage temperature	Tstg	-55~150								°C
Mounting torque	Tor	Rating Torque : 0.8 (Suggests 0.45~0.65)								N.m

Notes:

(1) Unit case mounted on aluminum plate heatsink

(2) Units mounted on P.C.B. without heatsink

# LD35SB10 Thru LD35SB160

## 2. Ratings and Characteristic Curves ( $T_A = 25^\circ\text{C}$ unless otherwise noted )

Fig. 1 Derating Curve

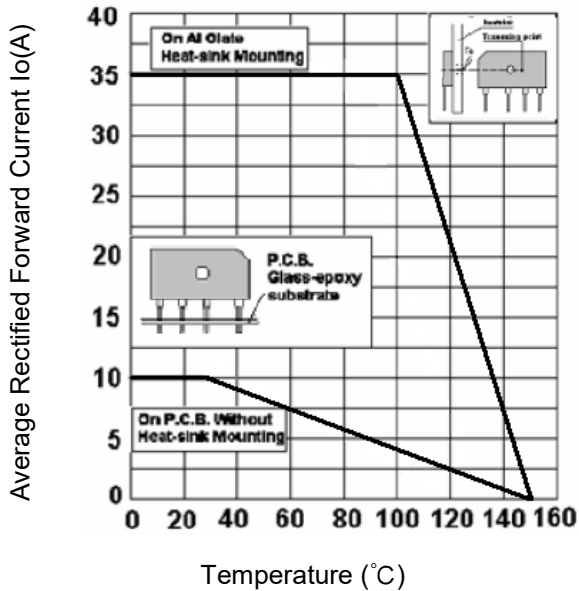

Fig.2 Typical Reverse Characteristics

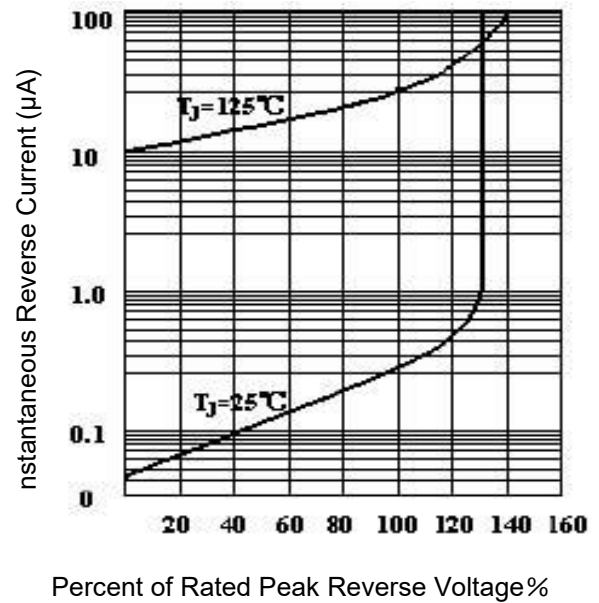

Fig.3 Forward Voltage

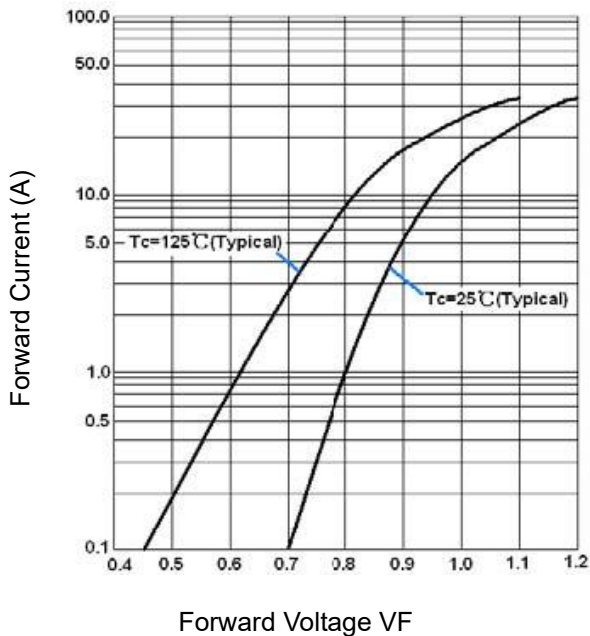
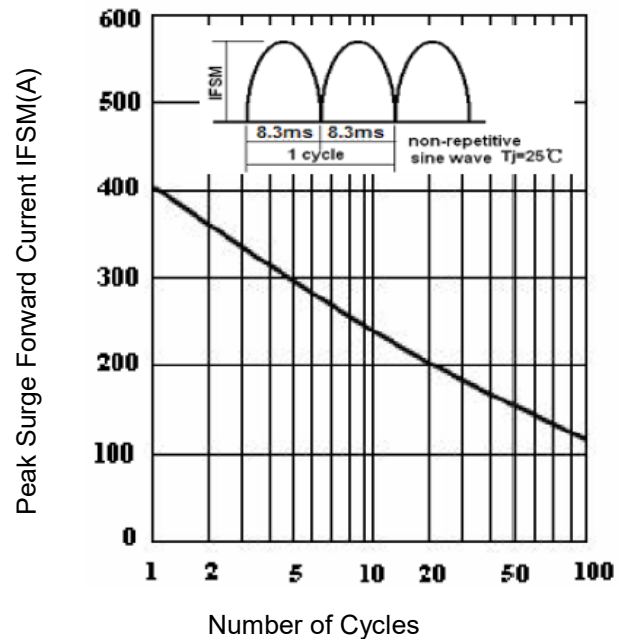
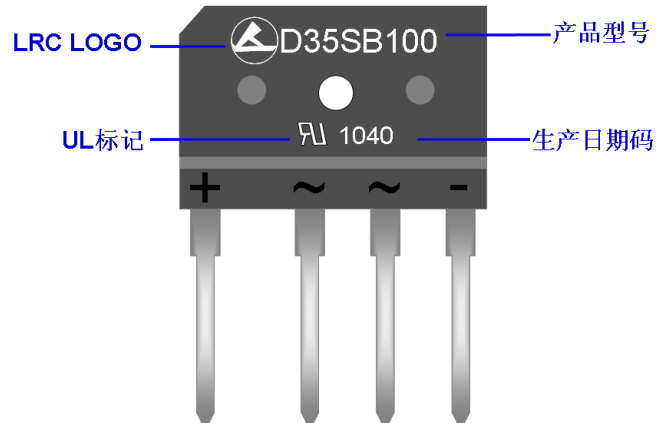

Fig.4 Peak Surge Forward Capability



# LD35SB10 Thru LD35SB160

## 3. Marking Identification



### Note:

生产日期码包含4位数字，例如“1040”，前两个数字“10”表示为2010年，另外二个数字“40”是指第40周，即表示该产品为2010年40周生产。

型号：**LD** **35** **SB** **100**

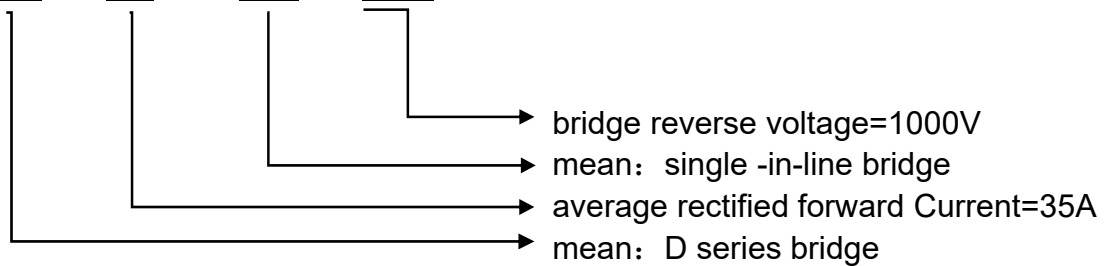

## 4. Package Dimensions

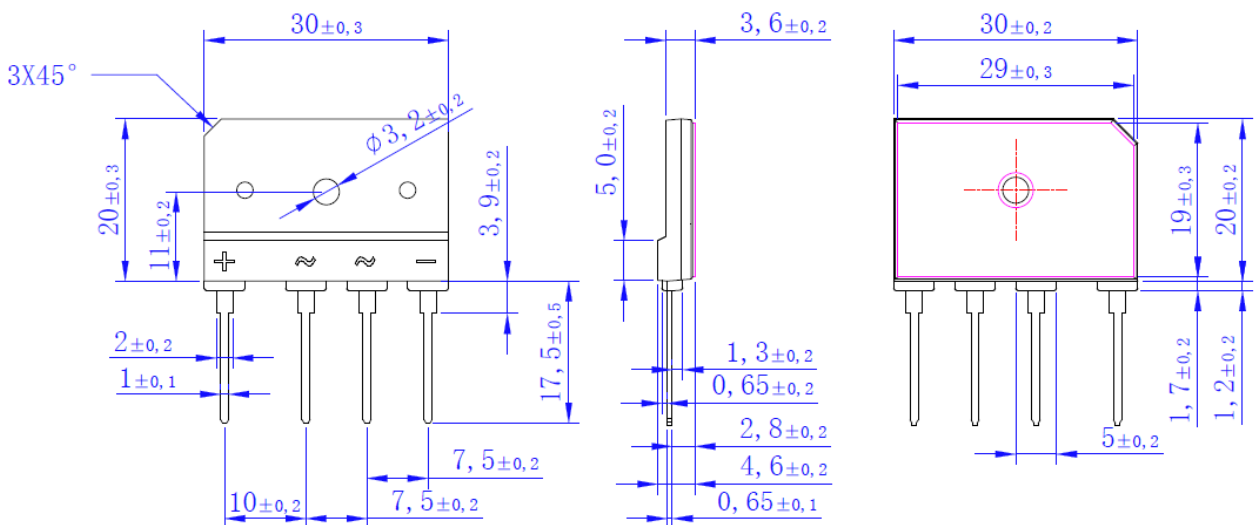

# LD35SB10 Thru LD35SB160

## 5. Update Record

版次	更新记录	更新作者	更新日期
1	初版发行	王锋	2019-5-9
2	增加电气绝缘间隙，调整外观图	陈帅	2022-8-2
3	增加LD35SB160规格参数	陈帅	2022-12-29

## DISCLAIMER

- Curve guarantee in the specification. The curve of test items with electric parameter is used as quality guarantee. The curve of test items without electric parameter is used as reference only.
- Before you use our Products for new Project, you are requested to carefully read this document and fully understand its contents. LRC shall not be in any way responsible or liable for failure, malfunction or accident arising from the use of any LRC's Products against warning, caution or note contained in this document.
- All information contained in this document is current as of the issuing date and subject to change without any prior notice. Before purchasing or using LRC's Products, please confirm the latest information with a LRC sales representative.