

## ESD3V3D3

### Description

ESD3V3D3 is designed to protect voltage sensitive components from ESD and transient voltage events. Excellent clamping capability, low leakage, and fast response time, make these parts ideal for ESD protection on designs where board space is at a premium. Because of its small size, it is suited for use in cellular phones, MP3 players, digital cameras and many other portable applications where board space is at a premium.

### Features

- Package: SOD-323
- Ultra low leakage
- Low operating voltage:3.3V
- Low clamping voltage
- Response Time is Typically < 1 ns
- Complies with following standards:
  - IEC 61000-4-2 (ESD) immunity test
    - Air discharge:  $\pm 30\text{kV}$
    - Contact discharge:  $\pm 30\text{kV}$
  - IEC61000-4-5 (Lightning) 20A (8/20 $\mu\text{s}$ )



### Applications

- Switches / Buttons
- Notebooks / Desktops /Servers
- Computer Peripherals
- Notebooks, Desktops, and Servers
- Point-of-Sale Terminals

### Circuit Diagram

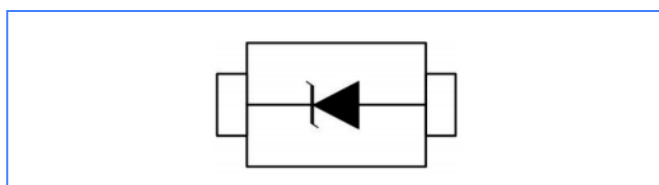

### Absolute Ratings

Tamb=25°C unless otherwise specified

Parameter	Symbol	Value	Unit
Peak pulse power (tp = 8/20 $\mu\text{s}$ )	P <sub>PK</sub>	300	W
Maximum Reverse Peak Pulse Current(8/20 $\mu\text{s}$ )	I <sub>PP</sub>	20	A
ESD per IEC 61000-4-2 (Air)	V <sub>ESD</sub>	$\pm 30$	KV
ESD per IEC 61000-4-2 (Contact)		$\pm 30$	
Storage Temperature Range	T <sub>STJ</sub>	-55 to +150	°C
Operating Temperature Range	T <sub>J</sub>	-55 to +125	°C

### Electrical Characteristics

TA=25°C unless otherwise specified

Symbol	Parameter	Conditions	Min	Typ	Max	Units
V <sub>RWM</sub>	Reverse Working Peak Voltage	-			3.3	V
V <sub>BR</sub>	Reverse Breakdown Voltage	I <sub>T</sub> = 1mA	5		7	V
I <sub>R</sub>	Reverse Current	V <sub>RWM</sub> =3.3V			0.5	$\mu\text{A}$
V <sub>C</sub>	Clamping Voltage	I <sub>PP</sub> =1A, t <sub>P</sub> =8/20 $\mu\text{s}$			12	V
V <sub>C</sub>	Clamping Voltage	I <sub>PP</sub> =20A, t <sub>P</sub> =8/20 $\mu\text{s}$			15	V
C <sub>D</sub>	Diode Capacitance	V <sub>R</sub> = 0V, f = 1MHz			200	pF

Characteristic Curves

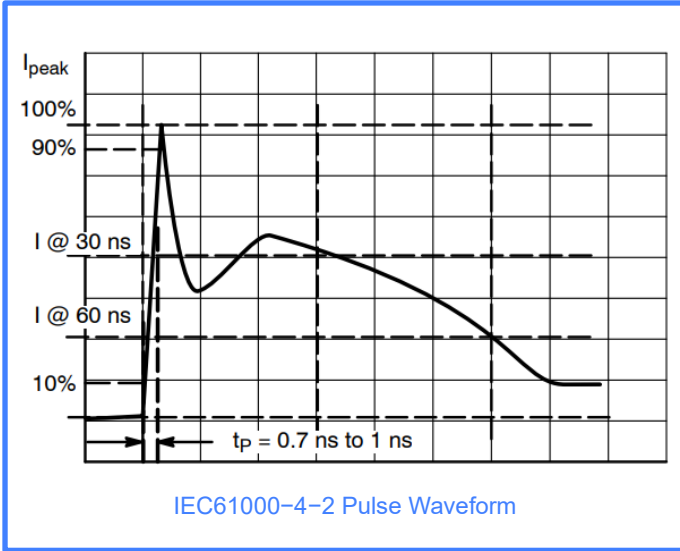

IEC61000-4-2 Pulse Waveform

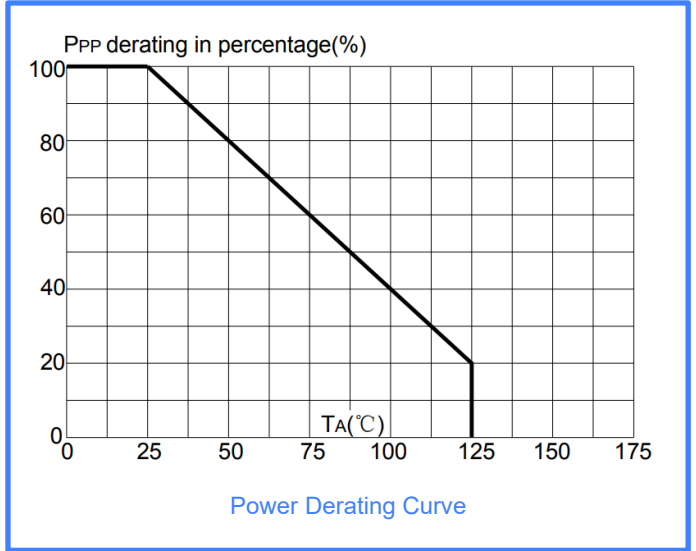

Power Derating Curve

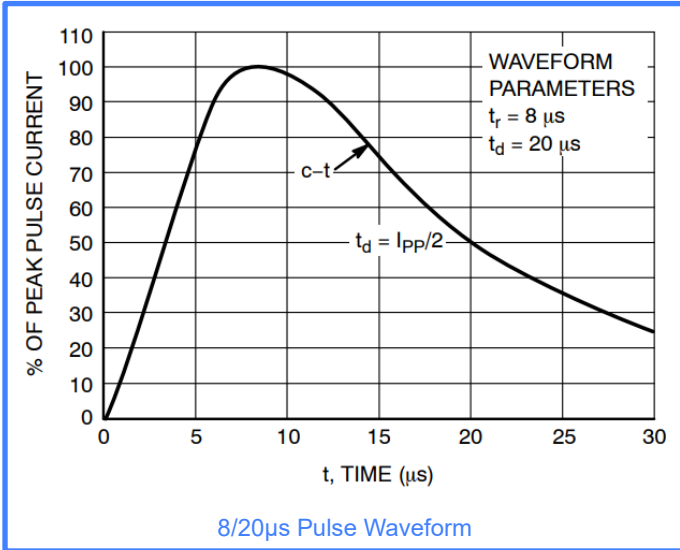

8/20µs Pulse Waveform

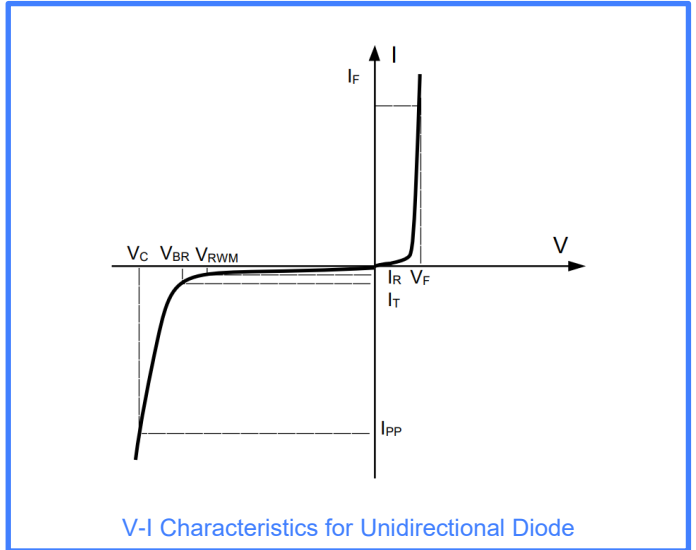

V-I Characteristics for Unidirectional Diode

**SOD323 Package Outline & Dimensions**

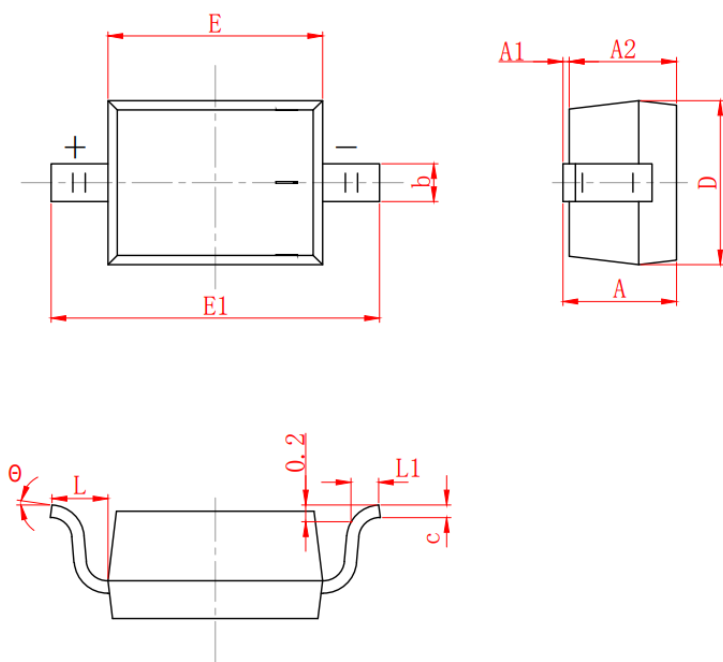

Symbol	Dimensions in mm	
	min	max
A		1.000
A1	0.000	0.100
A2	0.800	0.900
b	0.250	0.400
c	0.008	0.150
D	1.200	1.400
E	1.600	1.800
E1	2.300	2.700
L	0.475(REF)	
L1	0.250	0.400
$\theta$	0°	8°

**Disclaimer**

Specifications are subject to change without notice.

The device characteristics and parameters in this data sheet can and do vary in different applications and actual device performance may vary over time.

Users should verify actual device performance in their specific applications.