

DUAL LOW NOISE OPERATIONAL AMPLIFIER

FEATURES

- Internal Frequency Compensation Type.
- Wide Band Range : $f_T=3\text{MHz}$ (Typ.)
- Suitable Application for Active Filter and Equalizer Amplifier.
- Suffix U : Qualified to AEC-Q100
ex) KIA4558P/PU

PIN CONNECTION (TOP VIEW)

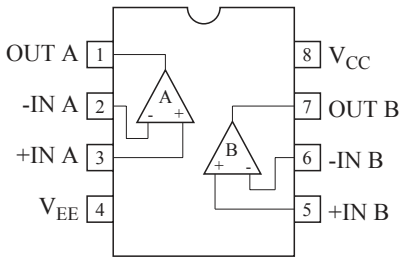

MARKING

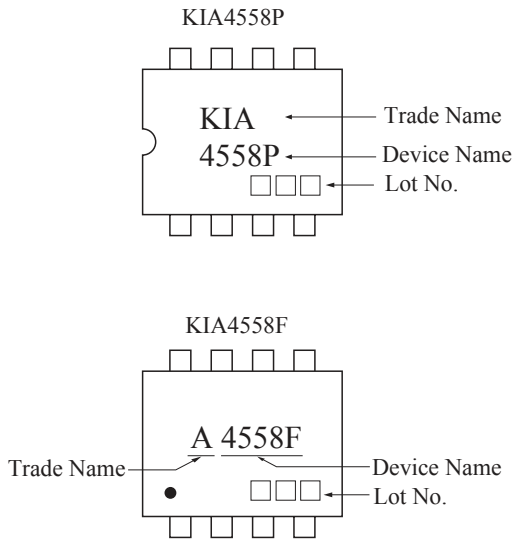

MAXIMUM RATINGS (Ta=25°C)

CHARACTERISTIC		SYMBOL	RATING	UNIT
Supply Voltage		V_{CC}	36 or 18	V
		V_{EE}	0 or -18	
Differential Input Voltage		D_{VIN}	± 30	V
Input Voltage		V_{IN}	$V_{CC} \sim V_{EE}$	V
Power Dissipation	KIA4558P	P_D	500	mW
	KIA4558F		240	
Operating Temperature		T_{opr}	-40 ~ 85	°C
Storage Temperature		T_{stg}	-55 ~ 125	°C

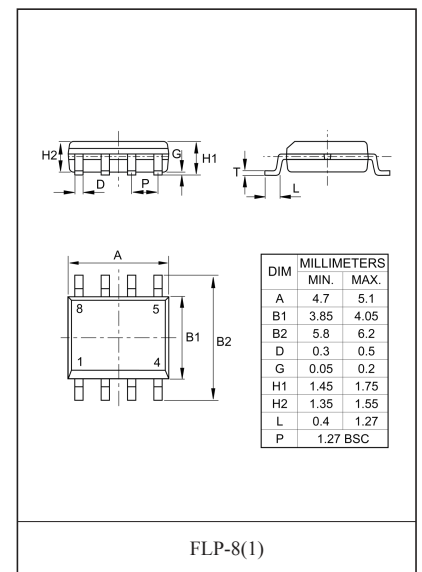
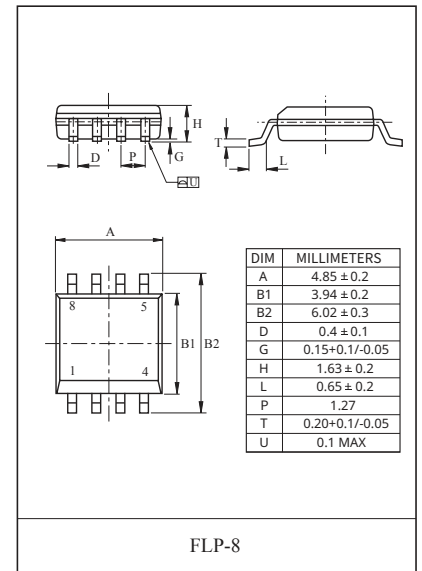
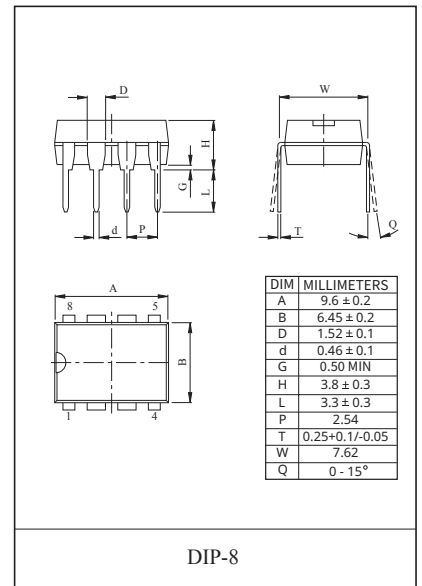

KIA4558P/F

EQUIVALENT CIRCUIT

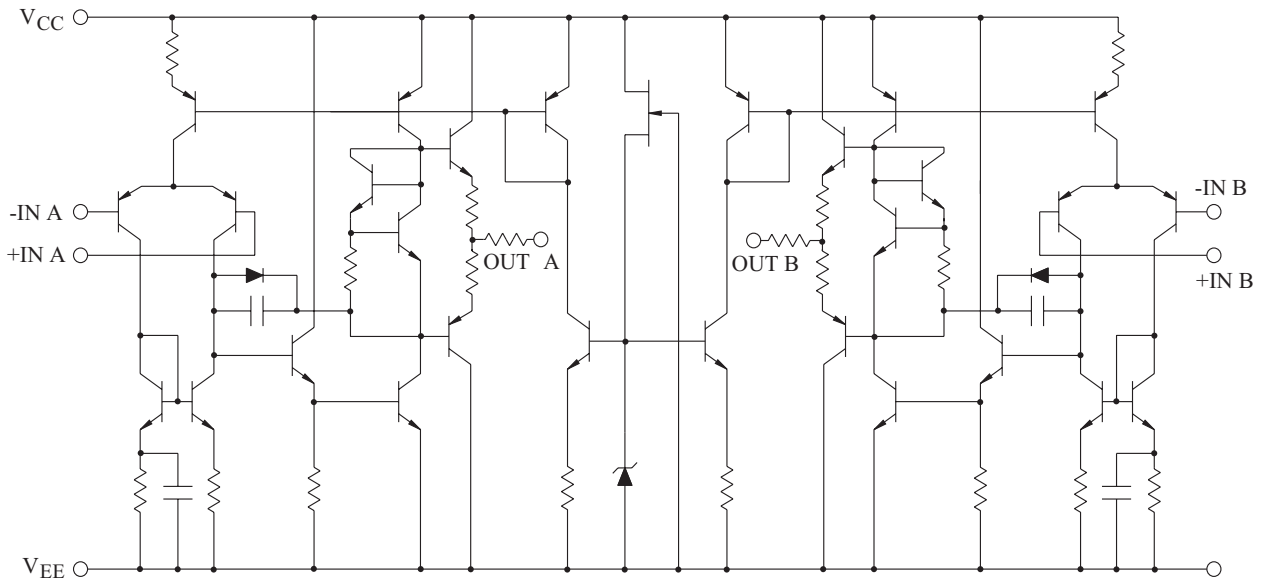

ELECTRICAL CHARACTERISTICS ($V_{CC}=15V$, $V_{EE}=-15$, $T_a=25^\circ C$)

CHARACTERISTIC	SYMBOL	TEST CIRCUIT	TEST CONDITION	Min.	TYP.	MAX.	UNIT
Input Offset Voltage	V_{IO}	-	$R_g \leq 10k\Omega$	-	0.5	6	mV
Input Offset Current	I_{IO}	-	-	-	5	200	nA
Input Bias Current	I_I	-	-	-	60	500	nA
Common Mode Input Voltage	CMV_{IN}	-	-	± 12	± 14	-	V
Maximum Output Voltage	V_{OM}	-	$R_L=10k\Omega$	± 12	± 14	-	V
	V_{OMR}		$R_L=2k\Omega$	± 10	± 13	-	
Source Current	I_{source}	-	-	27	-	-	mA
Sink Current	I_{sink}	-	-	27	-	-	mA
Voltage Gain (Open Loop)	G_V	-	$V_{OUT}=\pm 10V$, $R_L=2k\Omega$	86	100	-	dB
Common Mode Input Signal Rejection Ratio	CMRR	-	$R_g \leq 10k\Omega$	70	90	-	dB
Supply Voltage Rejection Ratio	SVRR	-	$R_g \leq 10k\Omega$	-	30	150	$\mu V/V$
Slew Rate	SR	-	$G_V=1$, $R_L=2k\Omega$	-	1.0	-	V/ μs
Unity Gain Cross Frequency	f_T	-	Open Loop	-	3.0	-	MHz
Supply Current	I_{CC} , I_{EE}	-	-	-	4.0	6.0	mA
Equivalent Input Noise Voltage	V_{NI}	-	$R_S=1k\Omega$, $f=30Hz \sim 30kHz$	-	2.5	-	μV_{rms}

KIA4558P/F

