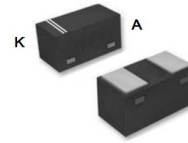

WSB5558N
Schottky Barrier Diode
<https://www.omnivision-group.com>
Features

- 100mA Average rectified forward current
- Low forward voltage
- Low leakage current
- Small package DFN1006-2L

DFN1006-2L

Applications

- Low Current rectification

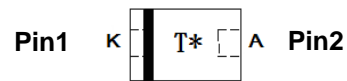
Circuit

Marking
Absolute maximum ratings

Parameter	Symbol	Value	Unit
Reverse voltage (repetitive peak)	V_{RM}	30	V
Reverse voltage (DC)	V_R	30	V
Average rectified forward current	I_O	100	mA
Peak forward surge current (8.3ms single sine pluse)	I_{FSM}	1	A
Junction temperature	T_J	150	°C
Operating temperature	$Topr$	-40 ~ 125	°C
Storage temperature	$Tstg$	-40 ~ 150	°C

Electronics characteristics ($T_A=25^{\circ}C$)

Parameter	Symbol	Condition	Min.	Typ.	Max.	Unit
Reverse Voltage	V_R	$I_R=100\mu A$	30			
Forward Voltage	V_F	$I_F=10mA$			0.35	V
		$I_F=100mA$			0.45	V
Reverse current	I_R	$V_R=10V$			15	μA
		$V_R=30V$			30	μA
Junction capacitance	C_J	$V_R=5V, F=1MHz$		21		pF
Thermal Resistance	$R_{\theta(JA)}$	Junction to Ambient			500	K/W

Order Informations

Device	Package	Marking	Shipping
WSB5558N-2/TR	DFN1006-2L	T*(1)	10000/Reel&Tape

Note 1: * = Month code(A~Z); T = Device code;

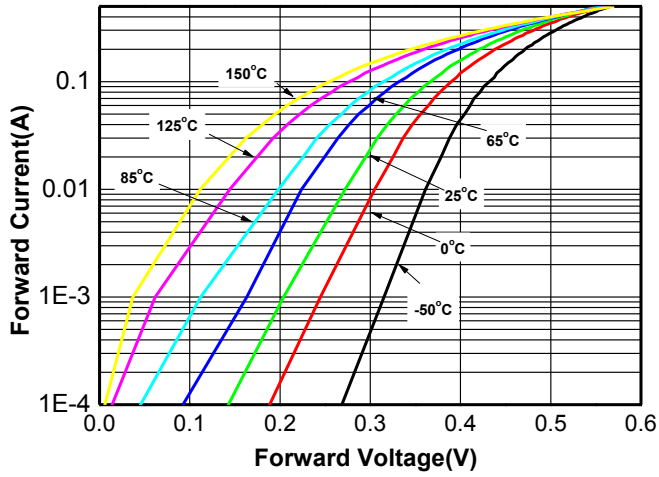
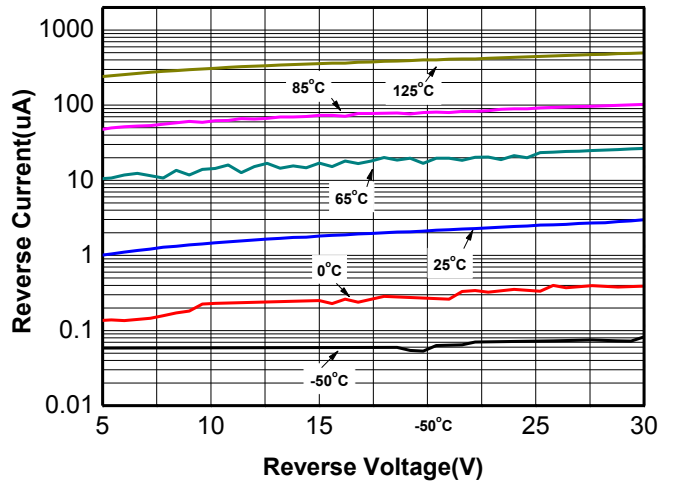
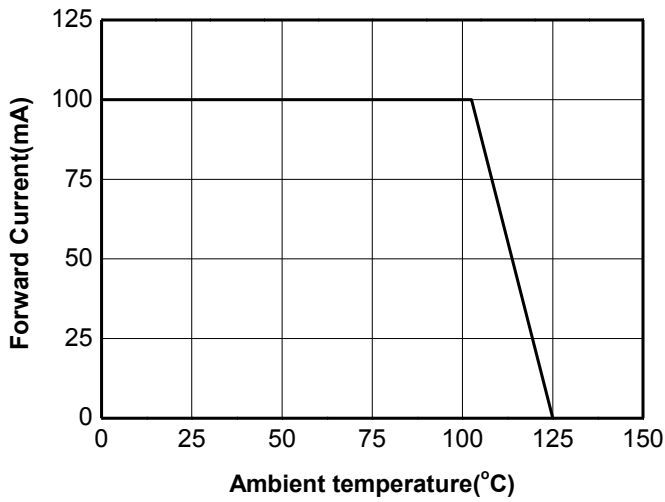
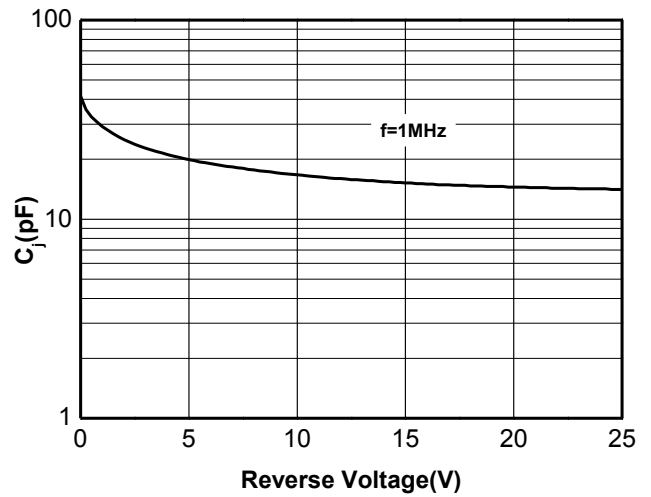
Typical characteristics (Ta=25°C, unless otherwise noted)

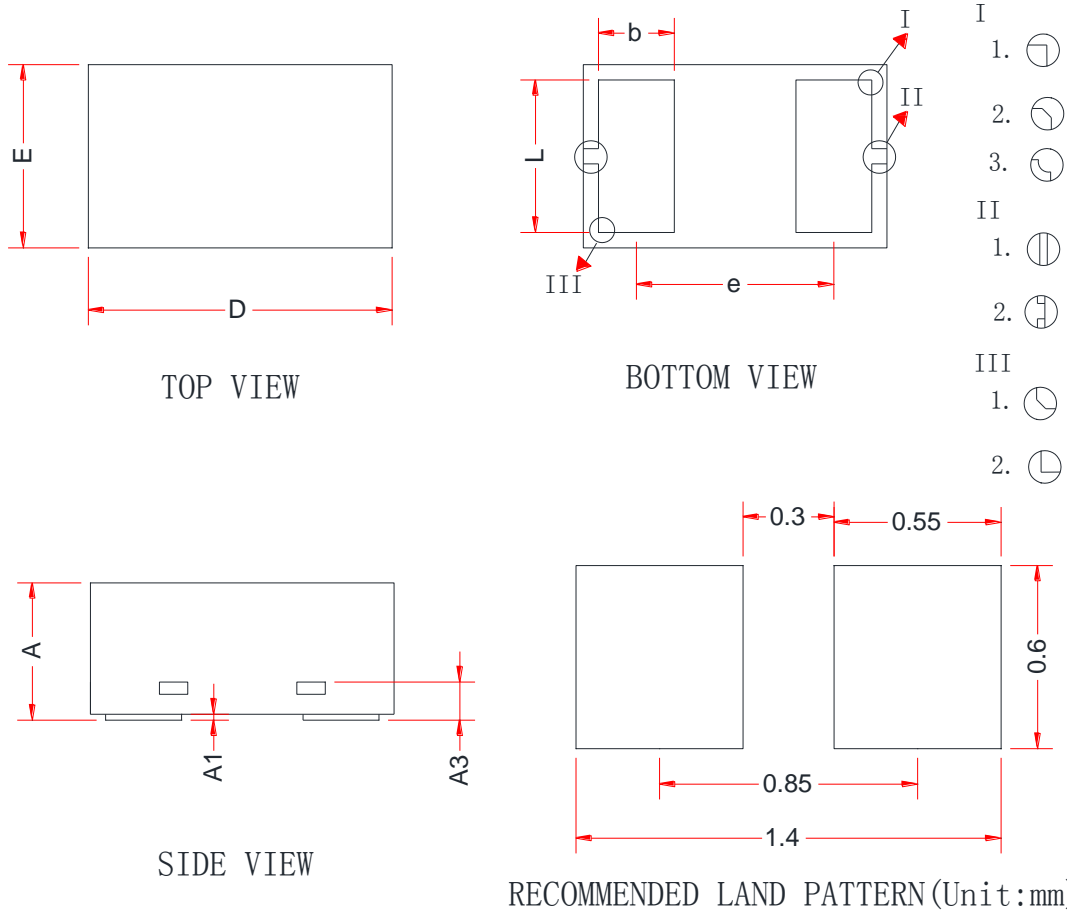
Forward voltage vs. Forward current

Reverse current vs. Reverse voltage

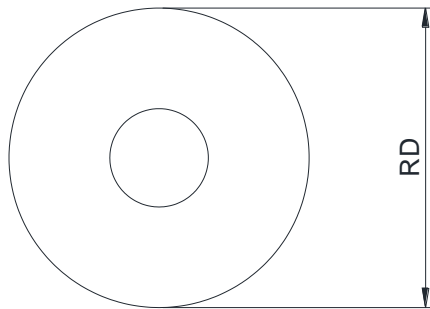
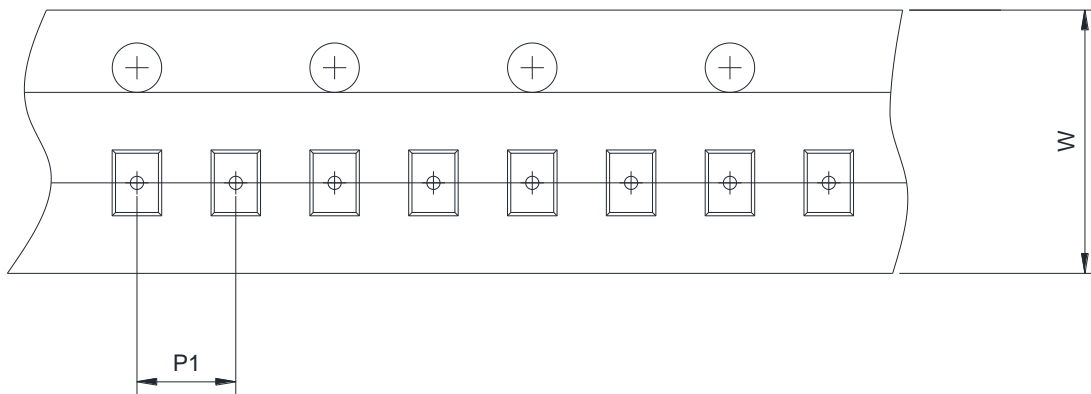
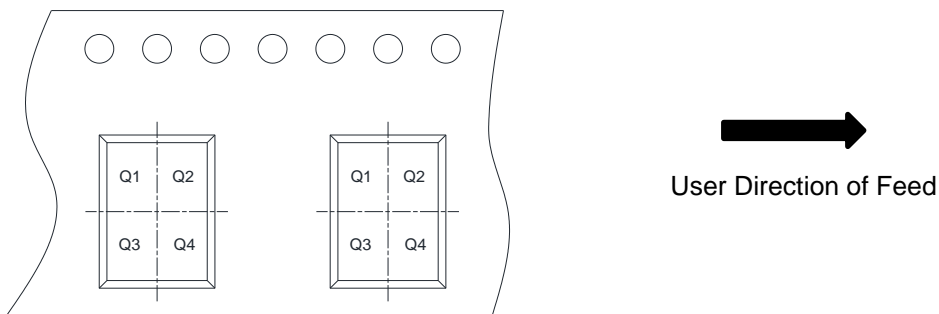
Forward current derating curve

Junction capacitance vs. Reverse voltage

PACKAGE OUTLINE DIMENSIONS
DFN1006-2L

Symbol	Dimensions in Millimeters		
	Min.	Typ.	Max.
A	0.36	0.45	0.53
A1	0.00	0.02	0.05
A3	0.125 Ref.		
D	0.95	1.00	1.05
E	0.55	0.60	0.65
b	0.20	0.25	0.30
L	0.45	0.50	0.55
e	0.65 BSC		

TAPE AND REEL INFORMATION
Reel Dimensions

Tape Dimensions

Quadrant Assignments For PIN1 Orientation In Tape

RD	Reel Dimension	<input checked="" type="checkbox"/> 7inch	<input type="checkbox"/> 13inch
W	Overall width of the carrier tape	<input checked="" type="checkbox"/> 8mm	<input type="checkbox"/> 12mm <input type="checkbox"/> 16mm
P1	Pitch between successive cavity centers	<input checked="" type="checkbox"/> 2mm	<input type="checkbox"/> 4mm <input type="checkbox"/> 8mm
Pin1	Pin1 Quadrant	<input checked="" type="checkbox"/> Q1	<input checked="" type="checkbox"/> Q2 <input type="checkbox"/> Q3 <input type="checkbox"/> Q4