

ISL6752

ZVS Full-Bridge Current-Mode PWM with Adjustable Synchronous Rectifier Control

FN9181  
Rev 4.00  
August 1, 2016

The [ISL6752](#) is a high-performance, low-pin count alternative Zero-Voltage Switching (ZVS) full-bridge PWM controller. Like Intersil's ISL6551, it achieves ZVS operation by driving the upper bridge FETs at a fixed 50% duty cycle while the lower bridge FETs are trailing-edge modulated with adjustable resonant switching delays. Compared to the more familiar phase-shifted control method, this algorithm offers equivalent efficiency and improved overcurrent and light load performance with less complexity in a lower pin count package.

The ISL6752 features complemented PWM outputs for Synchronous Rectifier (SR) control. The complemented outputs may be dynamically advanced or delayed relative to the PWM outputs using an external control voltage.

This advanced BiCMOS design features precision dead time and resonant delay control and an oscillator adjustable to 2MHz operating frequency. Additionally, multi-pulse suppression ensures alternating output pulses at low duty cycles where pulse skipping may occur.

**Related Literature**

- [AN1262](#), "Designing with the ISL6752, ISL6753 ZVS Full-Bridge Controllers"
- [AN1603](#), "ISL6752/54EVAL1Z ZVS DC/DC Power Supply with Synchronous Rectifiers User Guide"
- [AN1619](#), "Designing with ISL6752DBEVAL1Z and ISL6754DBEVAL1Z Control Cards"

**Features**

- Adjustable resonant delay for ZVS operation
- Synchronous rectifier control outputs with adjustable delay/advance
- Current-mode control
- 3% current limit threshold
- Adjustable dead time control
- 175µA start-up current
- Supply UVLO
- Adjustable oscillator frequency up to 2MHz
- Internal over-temperature protection
- Buffered oscillator sawtooth output
- Fast current sense to output delay
- Adjustable cycle-by-cycle peak current limit
- 70ns leading edge blanking
- Multi-pulse suppression
- Pb-free (RoHS compliant)

**Applications**

- ZVS full-bridge converters
- Telecom and datacom power
- Wireless base station power
- File server power
- Industrial power systems

**Pin Configuration**

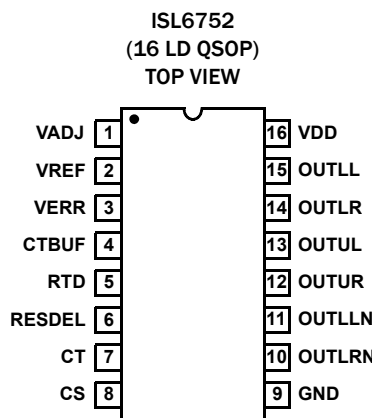

## Ordering Information

PART NUMBER (Notes 1, 2, 3)	PART MARKING	TEMP. RANGE (°C)	PACKAGE (RoHS COMPLIANT)	PKG. DWG. #
ISL6752AAZA	ISL 6752AAZ	-40 to +105	16 Ld QSOP	M16.15A
ISL6752/54EVAL1Z	Evaluation Board			
ISL6752DBEVAL1Z	Evaluation Board			

### NOTES:

1. Add "T" suffix for 2.5k unit Tape and Reel options. Please refer to [TB347](#) for details on reel specifications.
2. These Intersil Pb-free plastic packaged products employ special Pb-free material sets, molding compounds/die attach materials, and 100% matte tin plate plus anneal (e3 termination finish, which is RoHS compliant and compatible with both SnPb and Pb-free soldering operations). Intersil Pb-free products are MSL classified at Pb-free peak reflow temperatures that meet or exceed the Pb-free requirements of IPC/JEDEC J STD-020.
3. For Moisture Sensitivity Level (MSL), please see device information page for [ISL6752](#). For more information on MSL, please see tech brief [TB363](#)

**TABLE 1. KEY DIFFERENCES BETWEEN FAMILY OF PARTS**

PARAMETERS	ISL6754	ISL6753	ISL6752	ISL6551
Topology	Zero-Voltage Switching (ZVS)	Zero-Voltage Switching (ZVS)	Zero-Voltage Switching (ZVS)	Zero-Voltage-Switching (ZVS)
Topology Characteristic	Full-bridge ZVS	Full-bridge ZVS	Full-bridge ZVS	Full-bridge ZVS
Control Mode	Peak current-mode or voltage mode	Peak current-mode or voltage mode	Peak current-mode	Peak current-mode
UVLO Rising (V)	8.75V	8.75V	8.75V	9.6V
UVLO Falling (V)	7V	7V	7V	8.6V
V <sub>BIAS</sub> (maximum)	20V	20V	20V	16V
No-Load Operating Current	11mA (typical), 15.5mA (maximum)	11mA (typical), 15.5mA (maximum)	11mA (typical), 15.5mA (maximum)	13mA
# of PWM Outputs	6	4	6	6
FET Driver I <sub>OUT</sub> (maximum)	10mA	10mA	10mA	1A
Maximum Duty Cycle (%)	99	99	99	99

# Functional Block Diagram

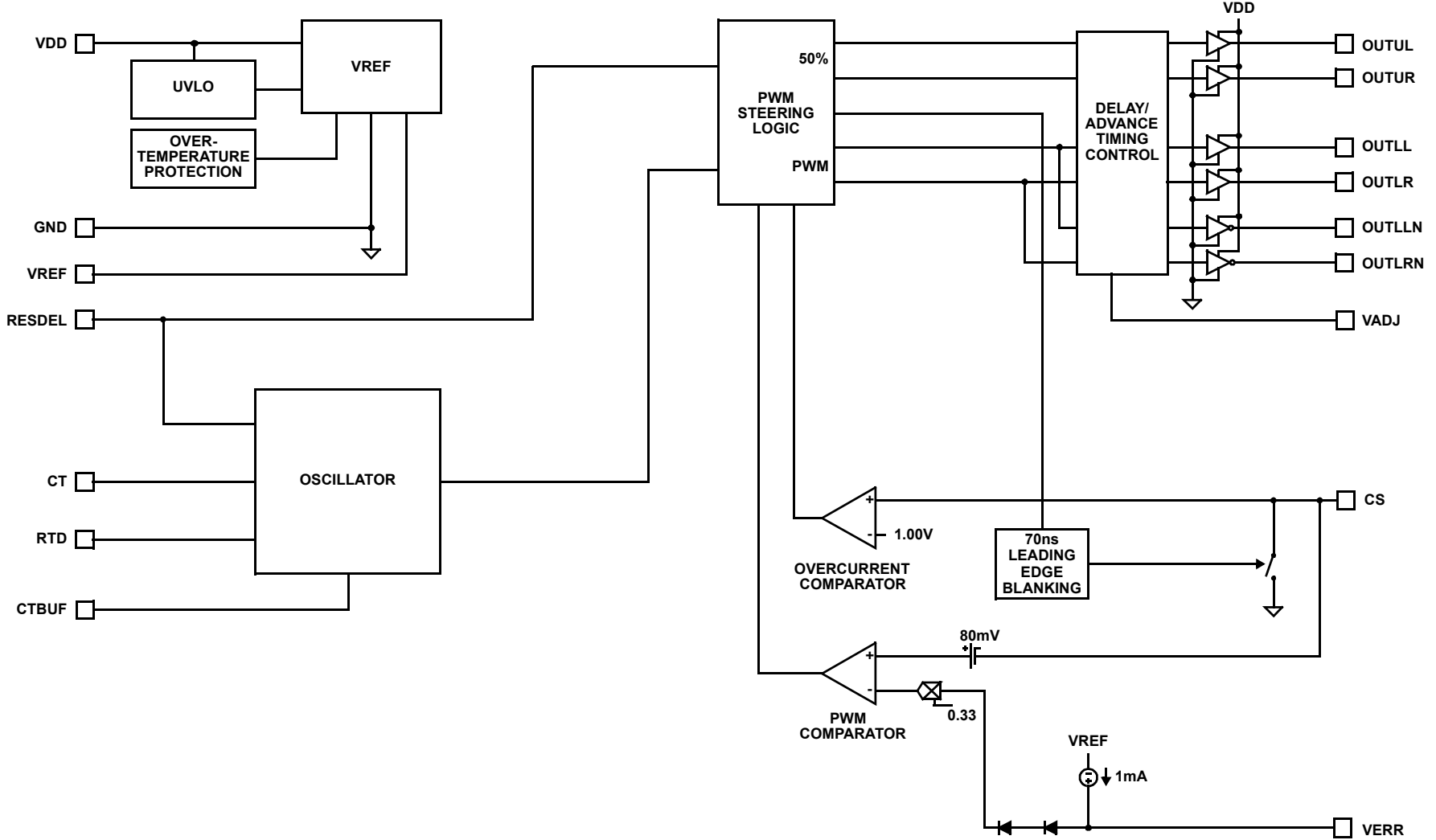

FIGURE 1. BLOCK DIAGRAM

# Typical Application - High Voltage Input Primary Side Control ZVS Full-Bridge Converter

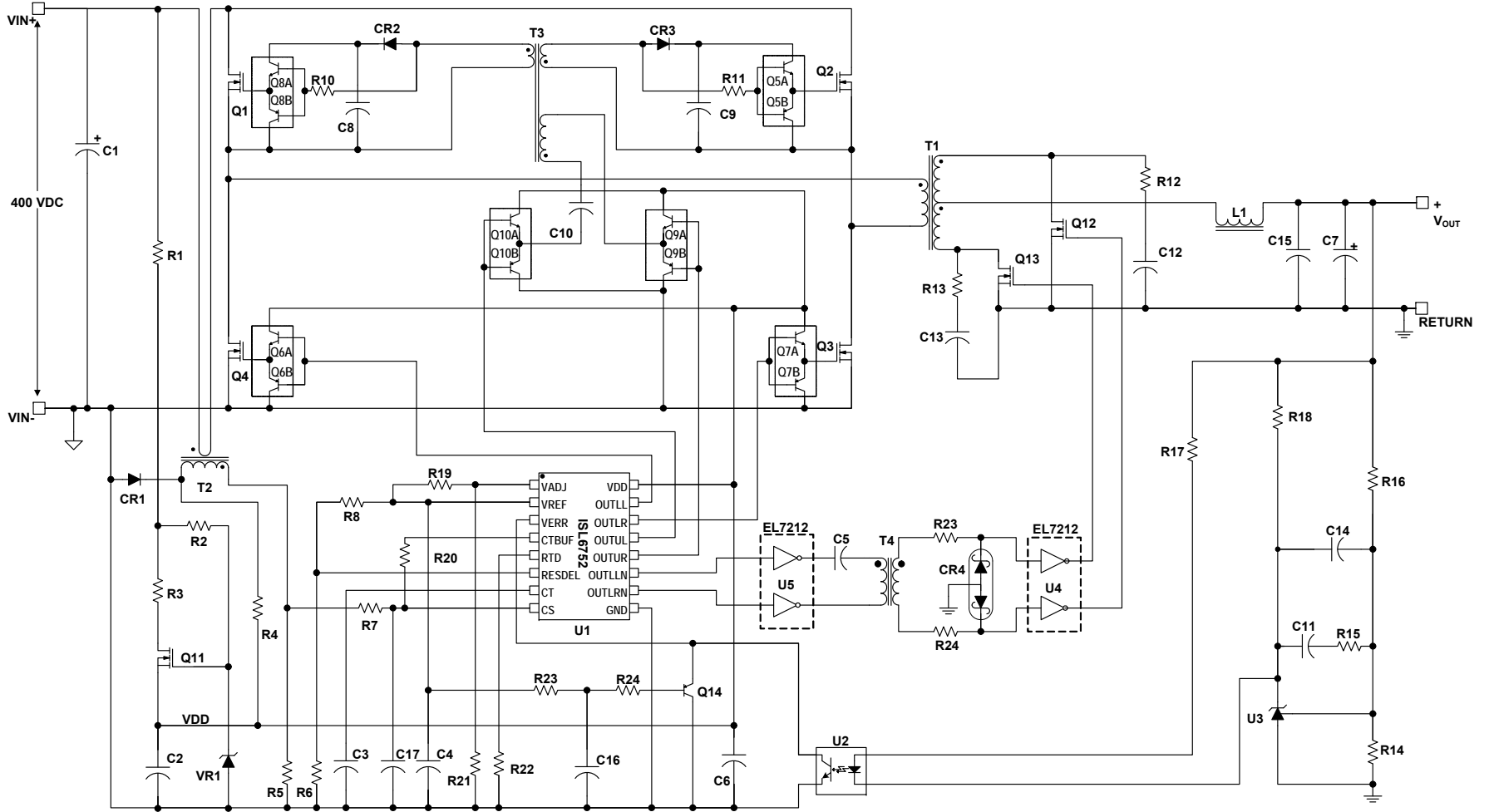

FIGURE 2. TYPICAL APPLICATION - HIGH VOLTAGE INPUT PRIMARY SIDE CONTROL ZVS FULL-BRIDGE CONVERTER

# Typical Application - High Voltage Input Secondary Side Control ZVS Full-Bridge Converter

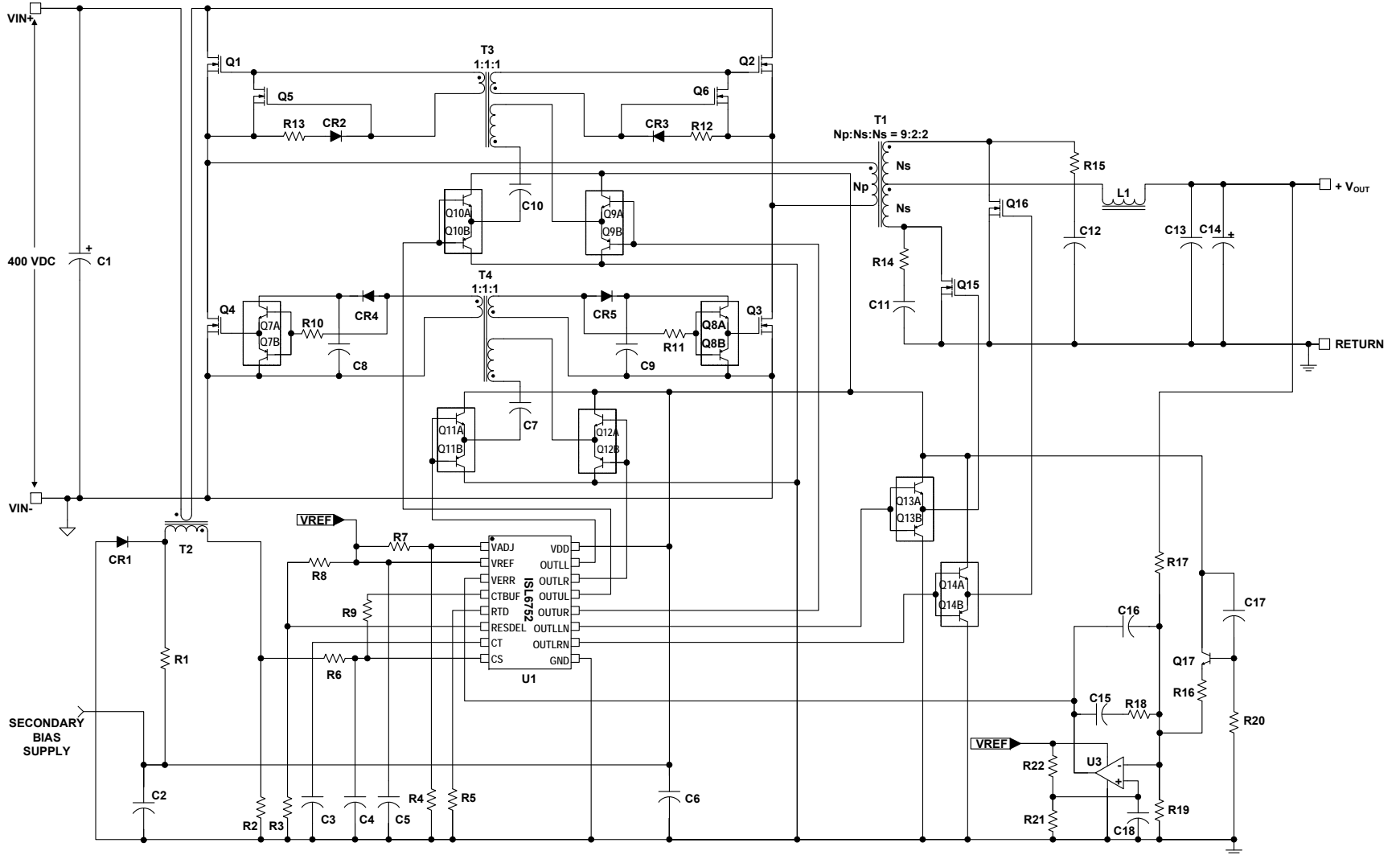

FIGURE 3. TYPICAL APPLICATION - HIGH VOLTAGE INPUT SECONDARY SIDE CONTROL ZVS FULL-BRIDGE CONVERTER

**Absolute Maximum Ratings** (Note 5)

Supply Voltage, VDD	(GND - 0.3V) to +20.0V
OUTxxx	(GND - 0.3V) to VDD
Signal Pins	(GND - 0.3V) to VREF + 0.3V
VREF	(GND - 0.3V) to 6.0V
Peak GATE Current	0.1A

**Thermal Information**

Thermal Resistance Junction to Ambient (Typical)	$\theta_{JA}$ (°C/W)
16 Ld QSOP (Note 4)	100
Maximum Junction Temperature	-55°C to +150°C
Maximum Storage Temperature Range	-65°C to +150°C
Pb-Free Reflow Profile	see <a href="#">TB493</a>

**Operating Conditions**

Temperature Range	-40°C to +105°C
Supply Voltage Range (Typical)	9VDC to 16VDC

**CAUTION:** Do not operate at or near the maximum ratings listed for extended periods of time. Exposure to such conditions may adversely impact product reliability and result in failures not covered by warranty.

**NOTES:**

- $\theta_{JA}$  is measured with the component mounted on a high effective thermal conductivity test board in free air. See Tech Brief [TB379](#) for details.
- All voltages are with respect to GND.

**Electrical Specifications** Recommended operating conditions unless otherwise noted. Refer to "[Functional Block Diagram](#)" on [page 3](#) and "typical application on [Figure 2 on page 4](#) and [Figure 3 on page 5](#). 9V < V<sub>DD</sub> < 20V, RTD = 10.0k $\Omega$  CT = 470pF, T<sub>A</sub> = -40°C to +105°C, Typical values are at T<sub>A</sub> = +25°C.

PARAMETER	TEST CONDITIONS	MIN (Note 10)	TYP	MAX (Note 10)	UNIT
<b>SUPPLY VOLTAGE</b>					
Supply Voltage		-	-	20	V
Start-Up Current, I <sub>DD</sub>	V <sub>DD</sub> = 5.0V	-	175	400	$\mu$ A
Operating Current, I <sub>DD</sub>	R <sub>LOAD</sub> , C <sub>OUT</sub> = 0	-	11.0	15.5	mA
UVLO START Threshold		8.00	8.75	9.00	V
UVLO STOP Threshold		6.50	7.00	7.50	V
Hysteresis		-	1.75	-	V
<b>REFERENCE VOLTAGE</b>					
Overall Accuracy	I <sub>VREF</sub> = 0mA to -10mA	4.850	5.000	5.150	V
Long Term Stability	T <sub>A</sub> = +125°C, 1000 hours (Note 6)	-	3	-	mV
Operational Current (Source)		-10	-	-	mA
Operational Current (Sink)		5	-	-	mA
Current Limit	V <sub>REF</sub> = 4.85V	-15	-	-100	mA
<b>CURRENT SENSE</b>					
Current Limit Threshold	VERR = V <sub>REF</sub>	0.97	1.00	1.03	V
CS to OUT Delay	Excl. LEB (Note 6)	-	35	50	ns
Leading Edge Blanking (LEB) Duration	(Note 6)	50	70	100	ns
CS to OUT Delay + LEB	T <sub>A</sub> = +25°C	-	-	130	ns
CS Sink Current Device Impedance	V <sub>CS</sub> = 1.1V	-	-	20	$\Omega$
Input Bias Current	V <sub>CS</sub> = 0.3V	-6.00	-	-2.00	$\mu$ A
CS to PWM Comparator Input Offset	T <sub>A</sub> = +25°C	65	80	95	mV
<b>PULSE WIDTH MODULATOR</b>					
VERR Pull-Up Current Source	VERR = 2.50V	0.80	1.00	1.30	mA
VERR V <sub>OH</sub>	I <sub>LOAD</sub> = 0mA	4.20	-	-	V
Minimum Duty Cycle	VERR < 0.6V	-	-	0	%

**Electrical Specifications** Recommended operating conditions unless otherwise noted. Refer to “Functional Block Diagram” on page 3 and “typical application on Figure 2 on page 4 and Figure 3 on page 5.  $9V < V_{DD} < 20V$ ,  $RTD = 10.0k\Omega$   $CT = 470pF$ ,  $T_A = -40^\circ C$  to  $+105^\circ C$ , Typical values are at  $T_A = +25^\circ C$ . (Continued)

PARAMETER	TEST CONDITIONS	MIN (Note 10)	TYP	MAX (Note 10)	UNIT
Maximum Duty Cycle (Per Half-Cycle)	$V_{ERR} = 4.20V$ , $V_{CS} = 0V$ (Note 7)	-	94	-	%
	$RTD = 2.0k\Omega$ , $CT = 220pF$	-	97	-	%
	$RTD = 2.0k\Omega$ $CT = 470pF$	-	99	-	%
Zero Duty Cycle VERR Voltage		0.85	-	1.20	V
VERR to PWM Comparator Input Offset	$T_A = +25^\circ C$	0.7	0.8	0.9	V
VERR to PWM Comparator Input Gain		0.31	0.33	0.35	V/V
Common-Mode (CM) Input Range	(Note 6)	0	-	4.45	V
<b>OSCILLATOR</b>					
Frequency Accuracy, Overall	(Note 6)	165	183	201	kHz
		-10	-	10	%
Frequency Variation with VDD	$T_A = +25^\circ C$ , $(F_{20V} - F_{10V})/F_{10V}$	-	0.3	1.7	%
Temperature Stability	$V_{DD} = 10V$ , $ F_{40^\circ C} - F_{0^\circ C} /F_{0^\circ C}$	-	4.5	-	%
	$ F_{0^\circ C} - F_{105^\circ C} /F_{25^\circ C}$ (Note 6)	-	1.5	-	%
Charge Current	$T_A = +25^\circ C$	-193	-200	-207	$\mu A$
Discharge Current Gain		19	20	23	$\mu A/\mu A$
CT Valley Voltage	Static Threshold	0.75	0.80	0.88	V
CT Peak Voltage	Static Threshold	2.75	2.80	2.88	V
CT Peak-to-Peak Voltage	Static Value	1.92	2.00	2.05	V
RTD Voltage		1.97	2.00	2.03	V
RESDEL Voltage Range		0	-	2.00	V
CTBUF Gain ( $V_{CTBUFp-p}/V_{CTp-p}$ )	$V_{CT} = 0.8V$ , 2.6V	1.95	2.0	2.05	V/V
CTBUF Offset from GND	$V_{CT} = 0.8V$	0.34	0.40	0.44	V
CTBUF $V_{OH}$	$\Delta V(I_{LOAD} = 0mA, I_{LOAD} = -2mA)$ , $V_{CT} = 2.6V$	-	-	0.10	V
CTBUF $V_{OL}$	$\Delta V(I_{LOAD} = 2mA, I_{LOAD} = 0mA)$ , $V_{CT} = 0.8V$	-	-	0.10	V
<b>OUTPUT</b>					
High Level Output Voltage ( $V_{OH}$ )	$I_{OUT} = -10mA$ , $V_{DD}$ to $V_{OH}$	-	0.5	1.0	V
Low Level Output Voltage ( $V_{OL}$ )	$I_{OUT} = 10mA$ , $V_{OL}$ to GND	-	0.5	1.0	V
Rise Time	$C_{OUT} = 220pF$ , $V_{DD} = 15V$ (Note 6)	-	110	200	ns
Fall Time	$C_{OUT} = 220pF$ , $V_{DD} = 15V$ (Note 6)	-	90	150	ns
UVLO Output Voltage Clamp	$V_{DD} = 7V$ , $I_{LOAD} = 1mA$ (Note 8)	-	-	1.25	V
Output Delay/Advance Range OUTLLN/OUTLRN relative to OUTLL/OUTLR	$V_{ADJ} = 2.50V$ (Note 6)	-	-	3	ns
	$V_{ADJ} < 2.425V$	-40	-	-300	ns
	$V_{ADJ} > 2.575V$	40	-	300	ns
Delay/Advance Control Voltage Range OUTLLN/OUTLRN relative to OUTLL/OUTLR	OUTLxN Delayed	2.575	-	5.000	V
	OUTLxN Advanced	0	-	2.425	V

**Electrical Specifications** Recommended operating conditions unless otherwise noted. Refer to “[Functional Block Diagram](#)” on page 3 and “typical application on [Figure 2 on page 4](#) and [Figure 3 on page 5](#).  $9V < V_{DD} < 20V$ ,  $RTD = 10.0k\Omega$   $CT = 470pF$ ,  $T_A = -40^\circ C$  to  $+105^\circ C$ , Typical values are at  $T_A = +25^\circ C$ . (Continued)

PARAMETER	TEST CONDITIONS	MIN ( <a href="#">Note 10</a> )	TYP	MAX ( <a href="#">Note 10</a> )	UNIT
VADJ Delay Time	$T_A = +25^\circ C$ (OUTLx Delayed) ( <a href="#">Note 9</a> )				
	VADJ = 0	280	300	320	ns
	VADJ = 0.5V	92	105	118	ns
	VADJ = 1.0V	61	70	80	ns
	VADJ = 1.5V	48	55	65	ns
	VADJ = 2.0V	41	50	58	ns
	$T_A = +25^\circ C$ (OUTLxN Delayed)				
	VADJ = $V_{REF}$	280	300	320	ns
	VADJ = $V_{REF} - 0.5V$	86	100	114	ns
	VADJ = $V_{REF} - 1.0V$	59	68	77	ns
	VADJ = $V_{REF} - 1.5V$	47	55	62	ns
	VADJ = $V_{REF} - 2.0V$	41	48	55	ns
<b>THERMAL PROTECTION</b>					
Thermal Shutdown	<a href="#">(Note 6)</a>	130	140	150	$^\circ C$
Thermal Shutdown Clear	<a href="#">(Note 6)</a>	115	125	135	$^\circ C$
Hysteresis, Internal Protection	<a href="#">(Note 6)</a>	-	15	-	$^\circ C$

## NOTES:

6. Limits established by characterization and are not production tested.
7. This is the maximum duty cycle achievable using the specified values of RTD and CT. Larger or smaller maximum duty cycles may be obtained using other values for these components. See [Equations 1](#) through [3](#).
8. Adjust  $V_{DD}$  below the UVLO stop threshold prior to setting at 7V.
9. When OUTx is delayed relative to OUTLxN ( $VADJ < 2.425V$ ), the delay duration as set by VADJ should not exceed 90% of the CT discharge time (dead time) as determined by CT and RTD.
10. Parameters with MIN and/or MAX limits are 100% tested at  $+25^\circ C$ , unless otherwise specified. Temperature limits established by characterization and are not production tested.



## Typical Performance Curves

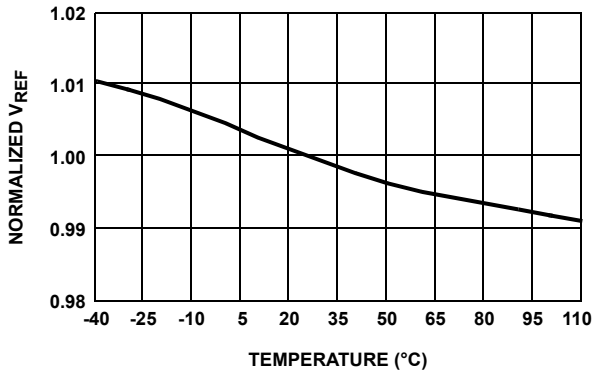

FIGURE 4. REFERENCE VOLTAGE vs TEMPERATURE

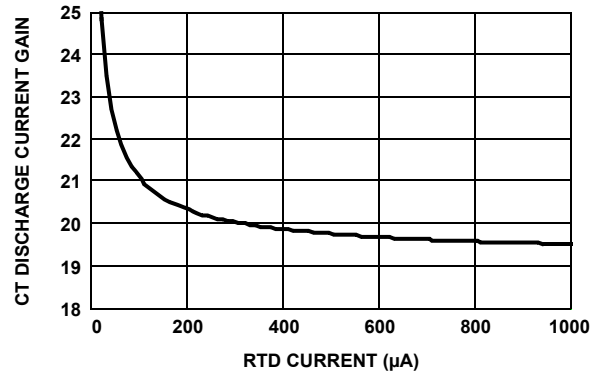

FIGURE 5. CT DISCHARGE CURRENT GAIN vs RTD CURRENT

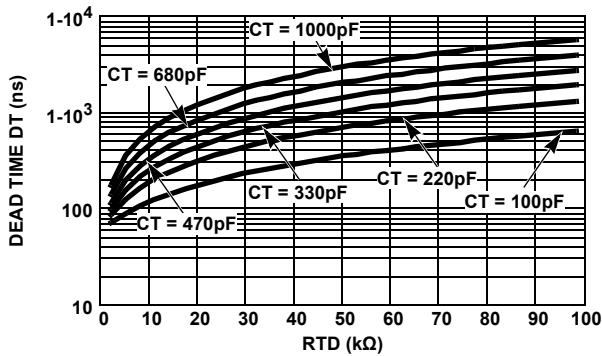

FIGURE 6. DEAD TIME (DT) vs CAPACITANCE

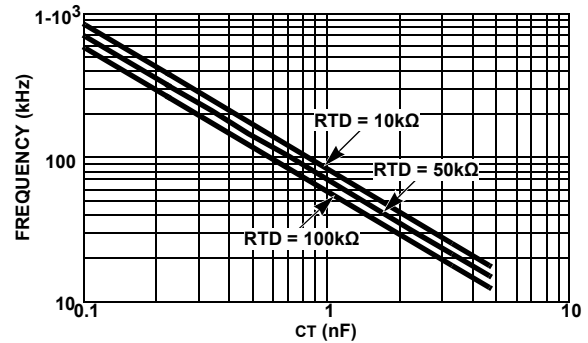

FIGURE 7. CAPACITANCE vs FREQUENCY

## Pin Descriptions

**VDD** - VDD is the power connection for the IC. To optimize noise immunity, bypass VDD to GND with a ceramic capacitor as close to the VDD and GND pins as possible.

VDD is monitored for supply voltage Undervoltage Lock-Out (UVLO). The start and stop thresholds track each other resulting in relatively constant hysteresis.

**GND** - Signal and power ground connections for this device. Due to high peak currents and high frequency operation, a low impedance layout is necessary. Ground planes and short traces are highly recommended.

**VREF** - The 5.0V reference voltage output having 3% tolerance over line, load and operating temperature. Bypass to GND with a 0.1 $\mu$ F to 2.2 $\mu$ F low ESR capacitor.

**CT** - The oscillator timing capacitor is connected between this pin and GND. It is charged through an internal 200 $\mu$ A current source and discharged with a user adjustable current source controlled by RTD.

**RTD** - This is the oscillator timing capacitor discharge current control pin. The current flowing in a resistor connected between this pin and GND determines the magnitude of the current that discharges CT. The CT discharge current is nominally 20x the resistor current. The PWM dead time is

determined by the timing capacitor discharge duration. The voltage at RTD is nominally 2V.

**CS** - This is the input to the overcurrent comparator. The overcurrent comparator threshold is set at 1V nominal. The CS pin is shorted to GND at the termination of either PWM output.

Depending on the current sensing source impedance, a series input resistor may be required due to the delay between the internal clock and the external power switch. This delay may result in CS being discharged prior to the power switching device being turned off.

**OUTUL and OUTUR** - These outputs control the upper bridge FETs and operate at a fixed 50% duty cycle in alternate sequence. OUTUL controls the upper left FET and OUTUR controls the upper right FET. The left and right designation may be switched as long as they are switched in conjunction with the lower FET outputs, OUTLL and OUTLR.

**RESDEL** - Sets the resonant delay period between the toggle of the upper FETs and the turn on of either of the lower FETs. The voltage applied to RESDEL determines when the upper FETs switch relative to a lower FET turning on. Varying the control voltage from 0V to 2V increases the resonant delay duration from 0 to 100% of the dead time. The control voltage divided by 2 represents the percent of the dead time equal to the resonant delay. In practice the maximum resonant delay must

be set lower than 2V to ensure that the lower FETs, at maximum duty cycle, are OFF prior to the switching of the upper FETs.

**OUTLL and OUTLR** - These outputs control the lower bridge FETs, are pulse width modulated, and operate in alternate sequence. OUTLL controls the lower left FET and OUTLR controls the lower right FET. The left and right designation may be switched as long as they are switched in conjunction with the upper FET outputs, OUTUL and OUTUR.

**OUTLLN and OUTLRN** - These outputs are the complements of the PWM (lower) bridge FETs. OUTLLN is the complement of OUTLL and OUTLRN is the complement of OUTLR. These outputs are suitable for control of synchronous rectifiers. The phase relationship between each output and its complement is controlled by the voltage applied to VADJ.

**VADJ** - A 0V to 5.0V control voltage applied to this input sets the relative delay or advance between OUTLL/OUTLR and OUTLLN/OUTLRN. The phase relationship between OUTUL/OUTUR and OUTLL/OUTLR is maintained regardless of the phase adjustment between OUTLL/OUTLR and OUTLLN/OUTLRN.

Voltages below 2.425V result in OUTLLN/OUTLRN being advanced relative to OUTLL/OUTLR. Voltages above 2.575V result in OUTLLN/OUTLRN being delayed relative to OUTLL/OUTLR. A voltage of  $2.50V \pm 75mV$  results in zero phase difference. A weak internal 50% divider from VREF results in no phase delay if this input is left floating.

The range of phase delay/advance is either zero or 40ns to 300ns with the phase differential increasing as the voltage deviation from 2.5V increases. The relationship between the control voltage and phase differential is non-linear. The gain ( $\Delta t/\Delta V$ ) is low for control voltages near 2.5V and rapidly increases as the voltage approaches the extremes of the control range. This behavior provides the user increased accuracy when selecting a shorter delay/advance duration.

When the PWM outputs are delayed relative to the SR outputs ( $VADJ < 2.425V$ ), the delay time should not exceed 90% of the dead time as determined by RTD and CT.

**VERR** - The control voltage input to the inverting input of the PWM comparator. The output of an external Error Amplifier (EA) is applied to this input, either directly or through an opto-coupler, for closed loop regulation. VERR has a nominal 1mA pull-up current source.

**CTBUF** - CTBUF is the buffered output of the sawtooth oscillator waveform present on CT and is capable of sourcing 2mA. It is offset from ground by 0.40V and has a nominal valley-to-peak gain of 2. It may be used for slope compensation.

## Functional Description

### Features

The ISL6752 PWM is an excellent choice for low cost ZVS full-bridge applications requiring adjustable synchronous rectifier drive. With its many protection and control features, a highly flexible design with minimal external components is possible. Among its many features are a very accurate overcurrent limit threshold, thermal protection, a buffered sawtooth oscillator output suitable for slope compensation, synchronous rectifier outputs with variable delay/advance timing, and adjustable frequency.

If synchronous rectification is not required, please consider the ISL6753 controller.

### Oscillator

The ISL6752 has an oscillator with a programmable frequency range to 2MHz, which can be programmed with a resistor and capacitor.

The switching period is the sum of the timing capacitor charge and discharge durations. The charge duration is determined by CT and a fixed 200 $\mu$ A internal current source. The discharge duration is determined by RTD and CT.

$$t_C \approx 11.5 \cdot 10^3 \cdot CT \quad S \quad (EQ. 1)$$

$$t_D \approx (0.06 \cdot RTD \cdot CT) + 50 \cdot 10^{-9} \quad S \quad (EQ. 2)$$

$$t_{SW} = t_C + t_D = \frac{1}{f_{SW}} \quad S \quad (EQ. 3)$$

Where  $t_C$  and  $t_D$  are the charge and discharge times, respectively, CT is the timing capacitor in Farads, RTD is the discharge programming resistance in ohms,  $t_{SW}$  is the oscillator period, and  $f_{SW}$  is the oscillator frequency. One output switching cycle requires two oscillator cycles. The actual times will be slightly longer than calculated due to internal propagation delays of approximately 10ns/transition. This delay adds directly to the switching duration, but also causes overshoot of the timing capacitor peak and valley voltage thresholds, effectively increasing the peak-to-peak voltage on the timing capacitor. Additionally, if very small discharge currents are used, there will be increased error due to the input impedance at the CT pin. The maximum recommended current through RTD is 1mA, which produces a CT discharge current of 20mA.

The maximum duty cycle, D, and percent dead time, DT, can be calculated from [Equations 4](#) and [5](#):

$$D = \frac{t_C}{t_{SW}} \quad (EQ. 4)$$

$$DT = 1 - D \quad (EQ. 5)$$

## Implementing Soft-Start

The ISL6752 does not have a soft-start feature. Soft-start can be implemented externally using the components shown in [Figure 5](#). The RC network governs the rate of rise of the transistor's base, which clamps the voltage at VERR.

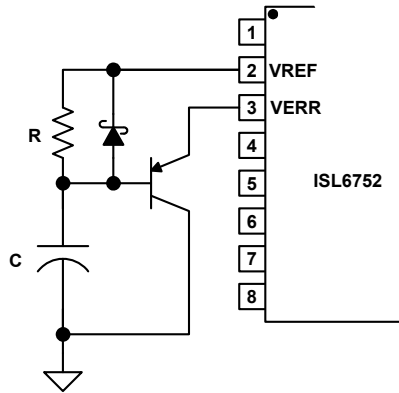

FIGURE 8. IMPLEMENTING SOFT-START

The values of R and C should be selected to control the rate of rise of VERR to the desired soft-start duration. The soft-start duration may be calculated from [Equation 6](#).

$$t = -RC \cdot \ln \left( 1 - \frac{V_{SS} - V_{be}}{V_{REF} + \frac{0.001R}{\beta}} \right) \quad \text{S} \quad (\text{EQ. 6})$$

Where  $V_{SS}$  is the soft-start clamp voltage,  $V_{be}$  is the base emitter voltage drop of the transistor, and  $\beta$  is the DC gain of the transistor. If  $\beta$  is sufficiently large, that term may be ignored. The Schottky diode discharges the soft-start capacitor so that the circuit may be reset quickly.

## Gate Drive

The ISL6752 outputs are capable of sourcing and sinking 10mA (at rated  $V_{OH}$ ,  $V_{OL}$ ) and are intended to be used in conjunction with integrated FET drivers or discrete bipolar totem pole drivers. The typical ON-resistance of the outputs is 50Ω.

## Overcurrent Operation

The cycle-by-cycle peak current control results in pulse-by-pulse duty cycle reduction when the current feedback signal exceeds 1.0V. When the peak current exceeds the threshold, the active output pulse is immediately terminated. This results in a well controlled decrease in output voltage as the load current increases beyond the current limit threshold. The ISL6752 will operate continuously in an overcurrent condition.

The propagation delay from CS exceeding the current limit threshold to the termination of the output pulse is increased by the Leading Edge Blanking (LEB) interval. The effective delay is the sum of the two delays and is nominally 105ns.

## Slope Compensation

Peak current-mode control requires slope compensation to improve noise immunity, particularly at lighter loads, and to prevent current loop instability, particularly for duty cycles greater than 50%. Slope compensation may be accomplished by summing an external ramp with the current feedback signal or by subtracting the external ramp from the voltage feedback error signal. Adding the external ramp to the current feedback signal is the more popular method.

From the small signal current-mode model [1] it can be shown that the naturally-sampled modulator gain,  $F_m$ , without slope compensation, is expressed in [Equation 7](#):

$$F_m = \frac{1}{S_n t_{SW}} \quad (\text{EQ. 7})$$

Where  $S_n$  is the slope of the sawtooth signal and  $t_{SW}$  is the duration of the half-cycle. When an external ramp is added, the modulator gain becomes [Equation 8](#):

$$F_m = \frac{1}{(S_n + S_e) t_{SW}} = \frac{1}{m_c S_n t_{SW}} \quad (\text{EQ. 8})$$

Where  $S_e$  is slope of the external ramp and:

$$m_c = 1 + \frac{S_e}{S_n} \quad (\text{EQ. 9})$$

The criteria for determining the correct amount of external ramp can be determined by appropriately setting the damping factor of the double-pole located at half the oscillator frequency. The double-pole will be critically damped if the Q-factor is set to 1, and over-damped for  $Q > 1$ , and under-damped for  $Q < 1$ . An under-damped condition can result in current loop instability.

$$Q = \frac{1}{\pi(m_c(1-D) - 0.5)} \quad (\text{EQ. 10})$$

Where D is the percent of on-time during a half cycle. Setting  $Q = 1$  and solving for  $S_e$  yields in [Equation 11](#):

$$S_e = S_n \left( \left( \frac{1}{\pi} + 0.5 \right) \frac{1}{1-D} - 1 \right) \quad (\text{EQ. 11})$$

Since  $S_n$  and  $S_e$  are the on-time slopes of the current ramp and the external ramp, respectively, they can be multiplied by  $t_{ON}$  to obtain the voltage change that occurs during  $t_{ON}$ .

$$V_e = V_n \left( \left( \frac{1}{\pi} + 0.5 \right) \frac{1}{1-D} - 1 \right) \quad (\text{EQ. 12})$$

Where  $V_n$  is the change in the current feedback signal during the on-time and  $V_e$  is the voltage that must be added by the external ramp.

$V_n$  can be solved for in terms of input voltage, current transducer components, and output inductance yielding in [Equation 13](#):

$$V_e = \frac{t_{SW} \cdot V_O \cdot R_{CS}}{N_{CT} \cdot L_O} \cdot \frac{N_S}{N_P} \left( \frac{1}{\pi} + D - 0.5 \right) \quad \text{V} \quad (\text{EQ. 13})$$

Where  $R_{CS}$  is the current sense burden resistor,  $N_{CT}$  is the current transformer turns ratio,  $L_O$  is the output inductance,  $V_O$  is the output voltage, and  $N_S$  and  $N_P$  are the secondary and primary turns, respectively.

The inductor current, when reflected through the isolation transformer and the current sense transformer to obtain the current feedback signal at the sense resistor yields in [Equation 14](#):

$$V_{CS} = \frac{N_S \cdot R_{CS}}{N_P \cdot N_{CT}} \left( I_O + \frac{D \cdot t_{SW}}{2L_O} \left( V_{IN} \cdot \frac{N_S}{N_P} - V_O \right) \right) \quad V \quad (\text{EQ. 14})$$

Where  $V_{CS}$  is the voltage across the current sense resistor and  $I_O$  is the output current at current limit.

Since the peak current limit threshold is 1.0V, the total current feedback signal plus the external ramp voltage must sum to this value.

$$V_e + V_{CS} = 1 \quad (\text{EQ. 15})$$

Substituting [Equations 13](#) and [14](#) into [Equation 15](#) and solving for  $R_{CS}$  yields in [Equation 16](#):

$$R_{CS} = \frac{N_P \cdot N_{CT}}{N_S} \cdot \frac{1}{I_O + \frac{V_O}{L_O} t_{SW} \left( \frac{1}{\pi} + \frac{D}{2} \right)} \quad \Omega \quad (\text{EQ. 16})$$

For simplicity, idealized components have been used for this discussion, but the effect of magnetizing inductance must be considered when determining the amount of external ramp to add. Magnetizing inductance provides a degree of slope compensation to the current feedback signal and reduces the amount of external ramp required. The magnetizing inductance adds primary current in excess of what is reflected from the inductor current in the secondary.

$$\Delta I_P = \frac{V_{IN} \cdot D t_{SW}}{L_m} \quad A \quad (\text{EQ. 17})$$

Where  $V_{IN}$  is the input voltage that corresponds to the duty cycle  $D$  and  $L_m$  is the primary magnetizing inductance. The effect of the magnetizing current at the current sense resistor,  $R_{CS}$ , is expressed in [Equation 18](#):

$$\Delta V_{CS} = \frac{\Delta I_P \cdot R_{CS}}{N_{CT}} \quad V \quad (\text{EQ. 18})$$

If  $\Delta V_{CS}$  is greater than or equal to  $V_e$ , then no additional slope compensation is needed and  $R_{CS}$  becomes [Equation 19](#):

$$R_{CS} = \frac{N_{CT}}{\frac{N_S}{N_P} \cdot \left( I_O + \frac{D t_{SW}}{2L_O} \cdot \left( V_{IN} \cdot \frac{N_S}{N_P} - V_O \right) \right) + \frac{V_{IN} \cdot D t_{SW}}{L_m}} \quad (\text{EQ. 19})$$

If  $\Delta V_{CS}$  is less than  $V_e$ , then [Equation 16](#) is still valid for the value of  $R_{CS}$ , but the amount of slope compensation added by the external ramp must be reduced by  $\Delta V_{CS}$ .

Adding slope compensation may be accomplished in the ISL6752 using the CTBUF signal. The CTBUF is an amplified

representation of the sawtooth signal that appears on the CT pin. It is offset from ground by 0.4V and is 2x the peak-to-peak amplitude of CT (0.4V to 4.4V). A typical application sums this signal with the current sense feedback and applies the result to the CS pin, as shown in [Figure 9](#).

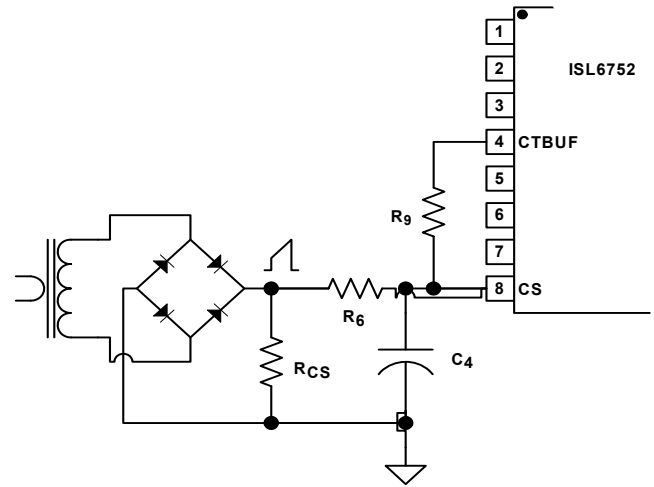

FIGURE 9. ADDING SLOPE COMPENSATION

Assuming the designer has selected values for the RC filter placed on the CS pin, the value of  $R_9$  required to add the appropriate external ramp can be found by superposition.

$$V_e - \Delta V_{CS} = \frac{(D(V_{CTBUF} - 0.4) + 0.4) \cdot R_6}{R_6 + R_9} \quad V \quad (\text{EQ. 20})$$

Rearranging to solve for  $R_9$  yields [Equation 21](#):

$$R_9 = \frac{(D(V_{CTBUF} - 0.4) - V_e + \Delta V_{CS} + 0.4) \cdot R_6}{V_e - \Delta V_{CS}} \quad \Omega \quad (\text{EQ. 21})$$

The value of  $R_{CS}$  determined in [Equations 16](#) must be rescaled so, that the current sense signal presented at the CS pin is that predicted by [Equation 14](#). The divider created by  $R_6$  and  $R_9$  makes this necessary.

$$R'_{CS} = \frac{R_6 + R_9}{R_9} \cdot R_{CS} \quad (\text{EQ. 22})$$

Example:

$$V_{IN} = 280V$$

$$V_O = 12V$$

$$L_O = 2.0\mu H$$

$$N_P/N_S = 20$$

$$L_m = 2mH$$

$$I_O = 55A$$

$$\text{Oscillator Frequency, } f_{SW} = 400kHz$$

$$\text{Duty Cycle, } D = 85.7\%$$

$$N_{CT} = 50$$

$$R_6 = 499\Omega$$

Solve for the current sense resistor,  $R_{CS}$ , using [Equation 16](#).

$$R_{CS} = 15.1\Omega.$$

Determine the amount of voltage,  $V_e$ , that must be added to the current feedback signal using [Equation 13](#).

$$V_e = 153mV$$

Next, determine the effect of the magnetizing current from [Equation 18](#).

$$\Delta V_{CS} = 91mV$$

Using [Equation 21](#), solve for the summing resistor,  $R_9$ , from CTBUF to CS.

$$R_9 = 30.1k\Omega$$

Determine the new value of  $R_{CS}$ ,  $R'_{CS}$ , using [Equation 22](#).

$$R'_{CS} = 15.4\Omega$$

This discussion determines the minimum external ramp that is required. Additional slope compensation may be considered for design margin.

If the application requires dead time of less than about 500ns, the CTBUF signal may not perform adequately for slope compensation. CTBUF lags the CT sawtooth waveform by 300ns to 400ns. This behavior results in a non-zero value of CTBUF when the next half-cycle begins when the dead time is short.

Under these situations, slope compensation may be added by externally buffering the CT signal as shown in [Figure 10](#).

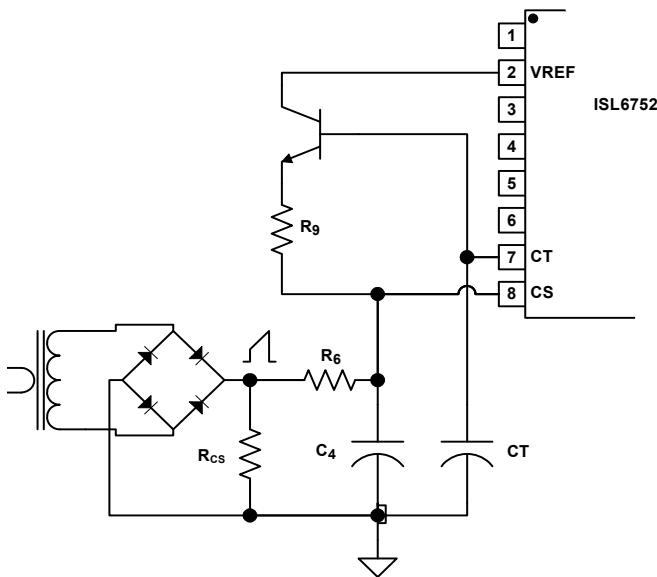

FIGURE 10. ADDING SLOPE COMPENSATION USING CT

Using CT to provide slope compensation instead of CTBUF requires the same calculations, except that [Equations 20](#) and [21](#) require modification. [Equation 20](#) becomes:

$$V_e - \Delta V_{CS} = \frac{2D \cdot R_6}{R_6 + R_9} \quad V \quad (EQ. 23)$$

and [Equation 21](#) becomes:

$$R_9 = \frac{(2D - V_e + \Delta V_{CS}) \cdot R_6}{V_e - \Delta V_{CS}} \quad \Omega \quad (EQ. 24)$$

The buffer transistor used to create the external ramp from CT should have a sufficiently high gain (>200) so as to minimize the required base current. Whatever base current is required reduces the charging current into CT and will reduce the oscillator frequency.

### ZVS Full-Bridge Operation

The ISL6752 is a full-bridge zero-voltage switching (ZVS) PWM controller that behaves much like a traditional hard switched topology controller. Rather than drive the diagonal bridge switches simultaneously, the upper switches (OUTUL, OUTUR) are driven at a fixed 50% duty cycle and the lower switches (OUTLL, OUTLR) are pulse width modulated on the trailing edge.

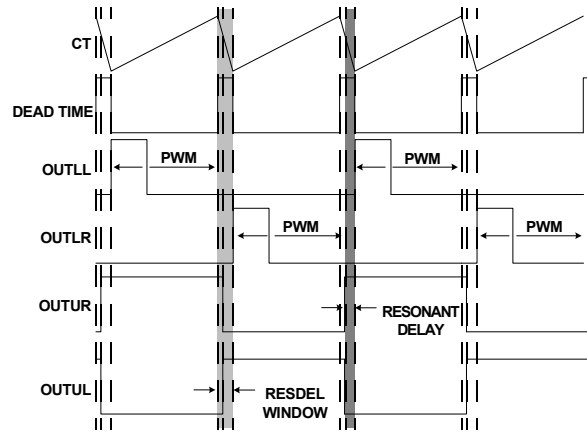

FIGURE 11. BRIDGE DRIVE SIGNAL TIMING

To understand how the ZVS method operates, one must include the parasitic elements of the circuit and examine a full switching cycle.

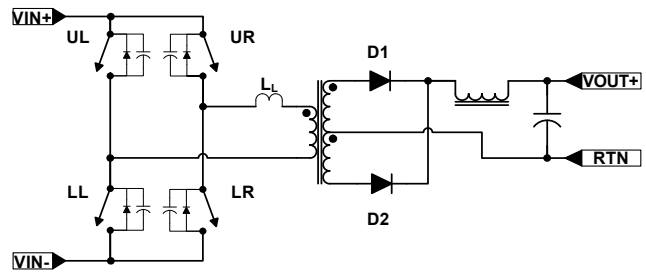

FIGURE 12. IDEALIZED FULL-BRIDGE

[Figure 12](#), the power semiconductor switches have been replaced by ideal switch elements with parallel diodes and capacitance, the output rectifiers are ideal, and the transformer leakage inductance has been included as a discrete element. The parasitic capacitance has been lumped together as switch capacitance, but represents all parasitic capacitance in the circuit including winding capacitance. Each switch is designated by its position; Upper Left (UL), Upper Right (UR), Lower Left (LL), and Lower Right (LR). The beginning of the cycle, shown in

Figure 13, is arbitrarily set as having switches UL and LR on and UR and LL off. The direction of the primary and secondary currents are indicated by  $I_p$  and  $I_s$ , respectively.

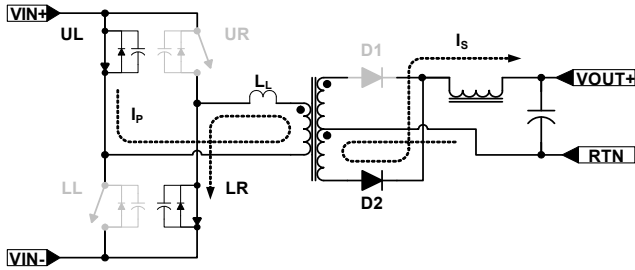

FIGURE 13. UL TO LR POWER TRANSFER CYCLE

The UL to LR power transfer period terminates when switch LR turns off as determined by the PWM. The current flowing in the primary cannot be interrupted instantaneously, so it must find an alternate path. The current flows into the parasitic switch capacitance of LR and UR, which charges the node to  $V_{IN}$  and then forward biases the body diode of upper switch UR.

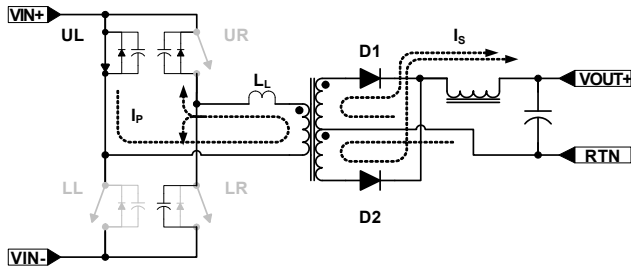

FIGURE 14. UL TO UR FREE-WHEELING PERIOD

The primary leakage inductance,  $L_L$ , maintains the current, which now circulates around the path of switch UL, the transformer primary, and switch UR. When switch LR opens, the output inductor current free-wheels through both output diodes, D1 and D2. During the switch transition, the output inductor current assists the leakage inductance in charging the upper and lower bridge FET capacitance.

The current flow from the previous power transfer cycle tends to be maintained during the free-wheeling period because the transformer primary winding is essentially shorted. Diode D1 may conduct very little or none of the free-wheeling current, depending on circuit parasitics. This behavior is quite different than occurs in a conventional hard-switched full-bridge topology where the free-wheeling current splits nearly evenly between the output diodes, and flows not at all in the primary.

This condition persists through the remainder of the half cycle.

During the period when CT discharges (also referred to as the dead time), the upper switches toggle. Switch UL turns off and switch UR turns on. The actual timing of the upper switch toggle is dependent on RESDEL, which sets the resonant delay. The voltage applied to RESDEL determines how far in advance the toggle occurs prior to a lower switch turning on. The ZVS transition occurs after the upper switches toggle and before the diagonal lower switch turns on. The required resonant delay is 1/4 of the period of the LC resonant frequency of the circuit

formed by the leakage inductance and the parasitic capacitance. The resonant transition may be estimated from Equation 25.

$$\tau = \frac{\pi}{2} \frac{1}{\sqrt{\frac{1}{L_L C_P} - \frac{R^2}{4L_L^2}}} \quad (\text{EQ. 25})$$

Where  $\tau$  is the resonant transition time,  $L_L$  is the leakage inductance,  $C_P$  is the parasitic capacitance, and  $R$  is the equivalent resistance in series with  $L_L$  and  $C_P$ .

The resonant delay is always less than or equal to the dead time and may be calculated using Equation 26.

$$\tau_{\text{resdel}} = \frac{V_{\text{resdel}}}{2} \cdot DT \quad \text{S} \quad (\text{EQ. 26})$$

Where  $\tau_{\text{resdel}}$  is the desired resonant delay,  $V_{\text{resdel}}$  is a voltage between 0V and 2V applied to the RESDEL pin, and  $DT$  is the dead time (see Equations 1 through 5).

When the upper switches toggle, the primary current that was flowing through UL must find an alternate path. It charges/discharges the parasitic capacitance of switches UL and LL until the body diode of LL is forward-biased. If RESDEL is set properly, switch LL will be turned on at this time. The output inductor does not assist this transition. It is purely a resonant transition driven by the leakage inductance.

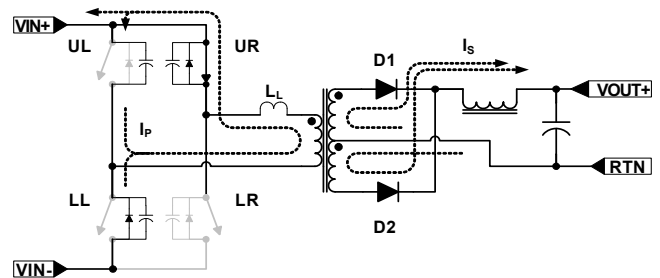

FIGURE 15. UPPER SWITCH TOGGLE AND RESONANT TRANSITION

The second power transfer period commences when switch LL closes. With switches UR and LL on, the primary and secondary currents flow, as indicated in Figure 16.

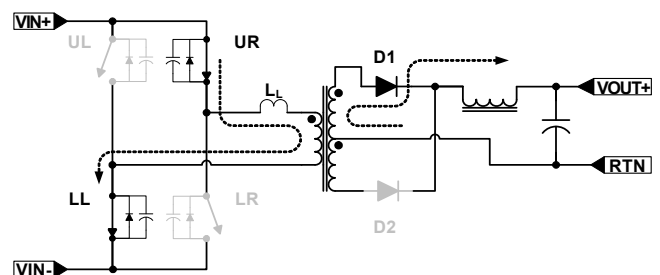

FIGURE 16. UR TO LL POWER TRANSFER CYCLE

The UR to LL power transfer period terminates when switch LL turns off, as determined by the PWM. The current flowing in the primary must find an alternate path. The current flows into the parasitic switch capacitance, which charges the node to  $V_{IN}$  and



then forward biases the body diode of upper switch UL. As before, the output inductor current assists in this transition. The primary leakage inductance,  $L_L$ , maintains the current, which now circulates around the path of switch UR, the transformer primary, and switch UL. When switch  $L_L$  opens, the output inductor current free wheels predominantly through diode D1. Diode D2 may actually conduct very little or none of the free-wheeling current, depending on circuit parasitics. This condition persists through the remainder of the half-cycle.

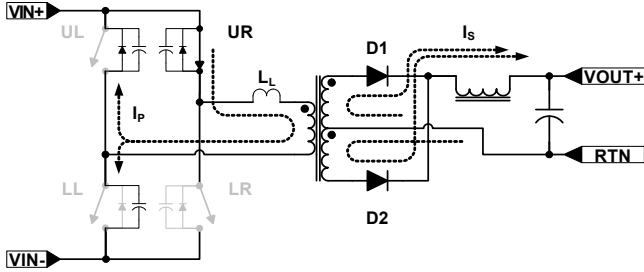

FIGURE 17. UR - UL FREE-WHEELING PERIOD

When the upper switches toggle, the primary current that was flowing through UR must find an alternate path. It charges/discharges the parasitic capacitance of switches UR and LR until the body diode of LR is forward-biased. If RESDEL is set properly, switch LR will be turned on at this time.

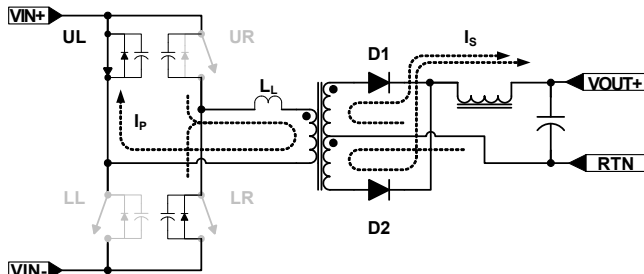

FIGURE 18. UPPER SWITCH TOGGLE AND RESONANT TRANSITION

The first power transfer period commences when switch LR closes and the cycle repeats. The ZVS transition requires that the leakage inductance has sufficient energy stored to fully charge the parasitic capacitances. Since the energy stored is proportional to the square of the current ( $1/2 L_L I_p^2$ ), the ZVS resonant transition is load dependent. If the leakage inductance is not able to store sufficient energy for ZVS, a discrete inductor may be added in series with the transformer primary.

### Synchronous Rectifier Outputs and Control

The ISL6752 provides double-ended PWM outputs, OUTLL and OUTLR, and Synchronous Rectifier (SR) outputs, OUTLLN and OUTLRN. The SR outputs are the complements of the PWM outputs. It should be noted that the complemented outputs are used in conjunction with the opposite PWM output, i.e., OUTLL and OUTLRN are paired together and OUTLR and OUTLLN are paired together.

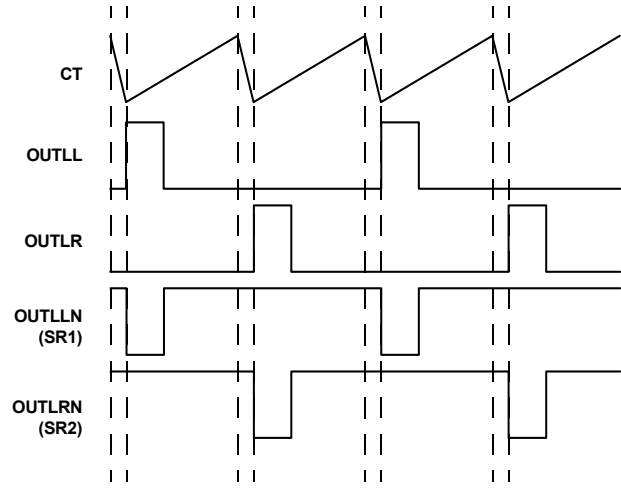

FIGURE 19. BASIC WAVEFORM TIMING

Referring to [Figure 19](#), the SRs alternate between being both on during the free-wheeling portion of the cycle (OUTLL/LR off) and one or the other being off when OUTLL or OUTLR is on. If OUTLL is on, its corresponding SR must also be on, indicating that OUTLRN is the correct SR control signal. Likewise, if OUTLR is on, its corresponding SR must also be on, indicating that OUTLLN is the correct SR control signal.

A useful feature of the ISL6752 is the ability to vary the phase relationship between the PWM outputs (OUTLL, OUTLR) and their complements (OUTLLN, OUTLRN) by  $\pm 300$ ns. This feature allows the designer to compensate for differences in the propagation times between the PWM FETs and the SR FETs. A voltage applied to VADJ controls the phase relationship.

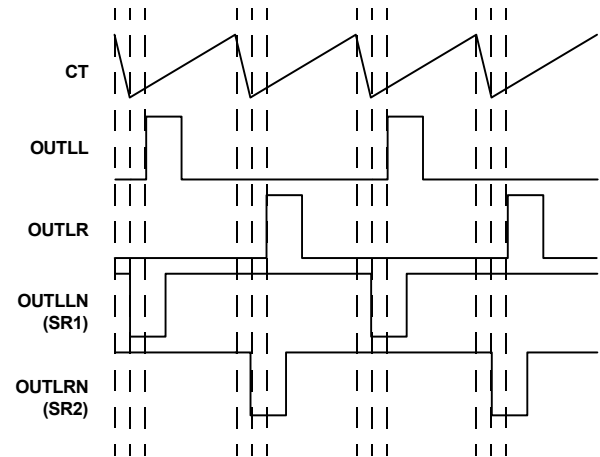

FIGURE 20. WAVEFORM TIMING WITH PWM OUTPUTS DELAYED,  $0V < VADJ < 2.425V$

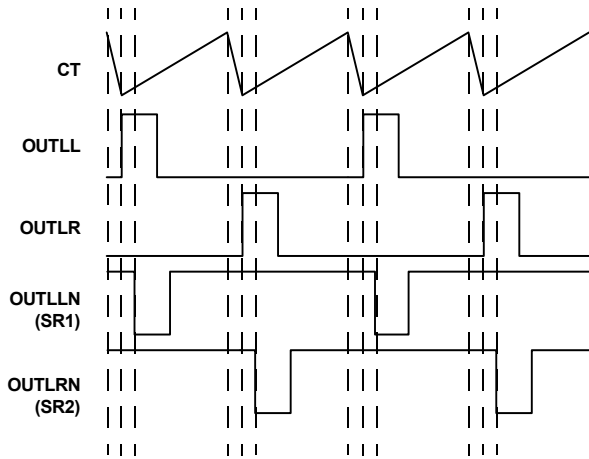

FIGURE 21. WAVEFORM TIMING WITH SR OUTPUTS DELAYED,  $2.575V < V_{ADJ} < 5.0V$

Setting  $V_{ADJ}$  to  $V_{REF}/2$  results in no delay on any output. The no delay voltage has a  $\pm 75mV$  tolerance window. Control voltages below the  $V_{REF}/2$  zero delay threshold cause the PWM outputs,  $OUTLL/LR$ , to be delayed. Control voltages greater than the  $V_{REF}/2$  zero delay threshold cause the SR outputs,  $OUTLLN/LRN$ , to be delayed. It should be noted that when the PWM outputs,  $OUTLL/LR$ , are delayed, the CS to output propagation delay is increased by the amount of the added delay.

The delay feature is provided to compensate for mismatched propagation delays between the PWM and SR outputs as may be experienced when one set of signals crosses the primary-secondary isolation boundary. If required, individual output pulses may be stretched or compressed as required using external resistors, capacitors and diodes.

When the PWM outputs are delayed, the 50% upper outputs are equally delayed, thus the resonant delay setting is unaffected.

### On/Off Control

The ISL6753 does not have a separate enable/disable control pin. The PWM outputs,  $OUTLL/OUTLR$ , may be disabled by pulling  $V_{ERR}$  to ground. Doing so reduces the duty cycle to zero, but the upper 50% duty cycle outputs,  $OUTUL/OUTUR$ , will continue operation. Likewise, the SR outputs  $OUTLLN/OUTLRN$  will be active high.

If the application requires that all outputs be off, then the supply voltage,  $V_{DD}$ , must be removed from the IC. This may be accomplished as shown in [Figure 19](#).

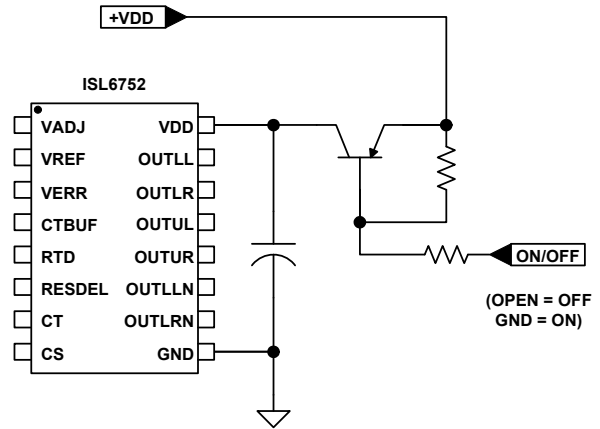

FIGURE 22. ON/OFF CONTROL USING VDD

### Fault Conditions

A fault condition occurs if  $V_{REF}$  or  $V_{DD}$  fall below their undervoltage lockout (UVLO) thresholds or if the thermal protection is triggered. When a fault is detected the outputs are disabled low. When the fault condition clears the outputs are re-enabled.

An overcurrent condition is not considered a fault and does not result in a shutdown.

### Thermal Protection

Internal die over-temperature protection is provided. An integrated temperature sensor protects the device should the junction temperature exceed  $+140^{\circ}C$ . There is approximately  $+15^{\circ}C$  of hysteresis.

### Ground Plane Requirements

Careful layout is essential for satisfactory operation of the device. A good ground plane must be employed.  $V_{DD}$  and  $V_{REF}$  should be bypassed directly to GND with good high frequency capacitance.

### References

- [1] Ridley, R., "A New Continuous-Time Model for Current Mode Control", IEEE Transactions on Power Electronics, Vol. 6, No. 2, April 1991.



**Revision History** The revision history provided is for informational purposes only and is believed to be accurate, but not warranted. Please go to the web to make sure that you have the latest revision.

DATE	REVISION	CHANGE
August 1, 2016	FN9181.4	<ul style="list-style-type: none"> <li>- Updated to new template.</li> <li>- On page 1: Added "Related Literature".</li> <li>- Ordering information table on page 2: Added "ISL6752/54EVAL1Z" and "ISL6752DBEVAL1Z". Updated Note 1 in the ordering information table to include tape and reel options.</li> <li>- Added Table 1 on page 2.</li> <li>- Electrical Specifications table on page 6: Updated "REFERENCE VOLTAGE" section, from "IVREF = 0mA to 10mA" to "0mA" to "-10mA".</li> <li>- Updated POD M16.15A to most recent revision with change as follows: Convert to new POD format. Added land pattern.</li> <li>- Added revision history and about Intersil verbiage.</li> </ul>

## About Intersil

Intersil Corporation is a leading provider of innovative power management and precision analog solutions. The company's products address some of the largest markets within the industrial and infrastructure, mobile computing and high-end consumer markets.

For the most updated datasheet, application notes, related documentation and related parts, please see the respective product information page found at [www.intersil.com](http://www.intersil.com).

You may report errors or suggestions for improving this datasheet by visiting [www.intersil.com/ask](http://www.intersil.com/ask).

Reliability reports are also available from our website at [www.intersil.com/support](http://www.intersil.com/support).

© Copyright Intersil Americas LLC 2005-2016. All Rights Reserved.  
All trademarks and registered trademarks are the property of their respective owners.

For additional products, see [www.intersil.com/en/products.html](http://www.intersil.com/en/products.html)

Intersil products are manufactured, assembled and tested utilizing ISO9001 quality systems as noted in the quality certifications found at [www.intersil.com/en/support/qualandreliability.html](http://www.intersil.com/en/support/qualandreliability.html)

*Intersil products are sold by description only. Intersil may modify the circuit design and/or specifications of products at any time without notice, provided that such modification does not, in Intersil's sole judgment, affect the form, fit or function of the product. Accordingly, the reader is cautioned to verify that datasheets are current before placing orders. Information furnished by Intersil is believed to be accurate and reliable. However, no responsibility is assumed by Intersil or its subsidiaries for its use; nor for any infringements of patents or other rights of third parties which may result from its use. No license is granted by implication or otherwise under any patent or patent rights of Intersil or its subsidiaries.*

For information regarding Intersil Corporation and its products, see [www.intersil.com](http://www.intersil.com)

# Package Outline Drawing

## M16.15A

16 LEAD SHRINK SMALL OUTLINE PLASTIC PACKAGE (QSOP/SSOP)

0.150" WIDE BODY

Rev 3, 8/12

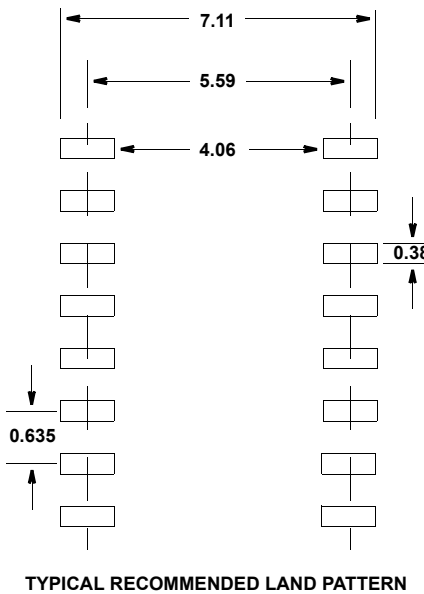
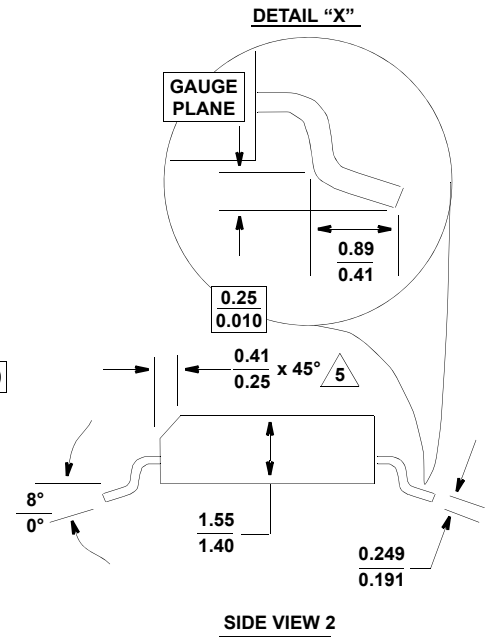
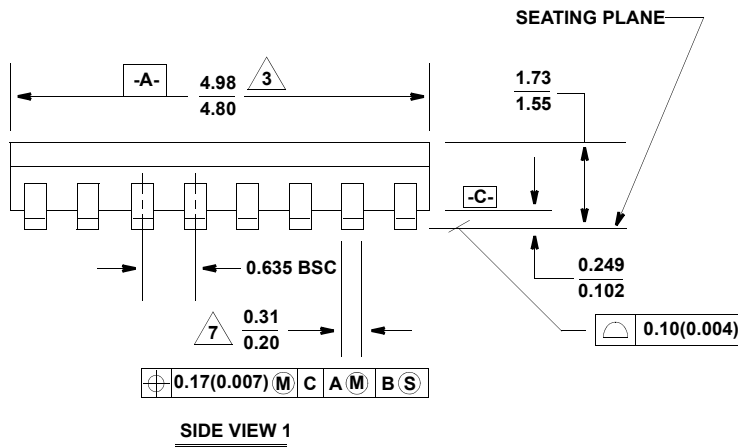
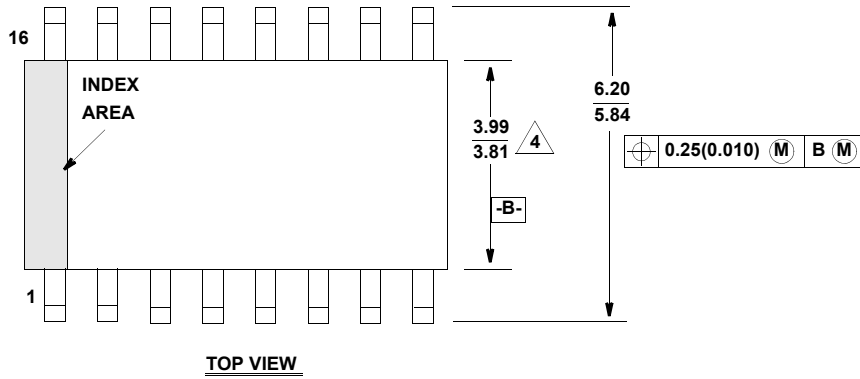

**NOTES:**

1. Symbols are defined in the "MO Series Symbol List" in Section 2.2 of Publication Number 95.
2. Dimensioning and tolerancing per ANSI Y14.5M-1994.
3. Package length does not include mold flash, protrusions or gate burrs. Mold flash, protrusion and gate burrs shall not exceed 0.15mm (0.006 inch) per side.
4. Package width does not include interlead flash or protrusions. Interlead flash and protrusions shall not exceed 0.25mm (0.010 inch) per side.
5. The chamfer on the body is optional. If it is not present, a visual index feature must be located within the crosshatched area.
6. Terminal numbers are shown for reference only.
7. Lead width does not include dambar protrusion. Allowable dambar protrusion shall be 0.10mm (0.004 inch) total in excess of "B" dimension at maximum material condition.
8. Controlling dimension: MILLIMETER.