

5050 内封 IC 单闪白光 贴片式发光二极管



特点 (Characteristics) :

- * 外观尺寸 (L/W/H) :5.0*5.0*1.6mm
outline Dimensions (L / w / h): 5.0*5.0*1.6mm
- * 发光颜色及胶体: 白光幻彩/透明胶体
Luminous color and colloid: Withe magic/Transparent colloid
- * 环保工艺符合 ROHS 要求
Environmental protection products Complied With ROHS Directive
- * 湿气敏感性等级 (MSL) :5a 级
Moisture sensitivity level (MSL) : 5a levels
- * EIA 规范标准包装
EIA standard packaging
- * 适用于 SMT 贴片自动化生产
Suitable for SMT automatic production
- * 适用于红外线回流焊制程
Suitable for infrared reflow soldering process

应用领域 (Product application) :

- * 发光字
luminous words
- * 模组
module
- * 点光源
Point light source
- * 灯条
Bar
- * 灯条屏
Lamp screen
- * 圣诞装饰等多场景产品
Christmas decorations and other multi-scene products



1、产品概述/Product Overview:

5050 内封 IC 是一款集成高质量专利技术单线级联恒流驱动 IC 和高质量白光 LED 芯片的外控恒流 5050 集成灯珠。其中内置控制 IC 是内部包含数据锁存电路、数据整形处理电路、数据转发电路、双振荡器、PWM 调制电路，以及白光三路 LED 恒流驱动电路。采用单线归零码的通讯协议。芯片在上电复位后，DI 口接收从 MCU 传输过来的数据帧，并通过数据锁存电路将数据帧里的头 24bit 数据锁存下来，并送至 PWM 调制电路，以控制白光 LED 恒流驱动电路的工作。数据帧的头 24bit 数据被锁存下来后，剩余的数据经过内部数据整形放大电路整形后通过数据转发电路经 DO 口转发至下一级的灯珠。数据帧每经过一颗灯珠的传输，数据便减少 24bit。

The 5050 internal IC is a kind of integrated high-quality patent technology single-line cascade constant-current drive IC and high-quality white LED chip external control constant-current 5050 integrated lamp beads. The built-in control IC includes data latch circuit, data shaping circuit, data forward circuit, dual oscillator, PWM modulation circuit, and three white LED constant current drive circuit. Adopt the communication protocol of single line return to zero code. After the power-on reset, the DI interface receives the data frame transmitted from MCU, and through the data latch circuit, the first 24bit data in the data frame is latched down, and sent to the PWM modulation circuit to control the work of the constant-current driving circuit of white LED. After the first 24bit data of the data frame is locked, the remaining data is processed by the internal data shaping amplifier circuit and then transmitted to the next stage of the lamp ball through the DO port through the data forwarding circuit. Every time the frame passes through a bead, the data is reduced by 24 bits.

2、功能特点/Functional characteristics:

2.1 电源电压 5V

Power Supply Voltage 5V

2.2 白光端口耐压最高达 12V

White light ports withstand up to 12V voltage

2.3 内置上电复位和掉电复位电路

Built-in power-on and power-off reset circuits

2.4 灰度调节电路（256 级灰度可调）；

Gray Level Adjustment Circuit (256 gray level adjustable).

2.5 内置数据整形电路，保证数据经过多级级联不会产生波形畸变累加

Built-in data shaping circuit to ensure that the data through the cascade will not generate wave distortion accumulation

2.6 数据传输频率可达 800Kbps

Data transmission frequency can reach 800Kbps

2.7 当刷新速率为 30 帧/秒时，芯片级联数可不小于 1024 点

At a refresh rate of 30 FPS, the number of cascades can be no less than 1024

目录

Catalogue

电性参数	
Electrical Characteristics.....	3
典型特性曲线	
Typical Characteristic Curves.....	9
可靠性实验	
Reliability Test Items And Conditions.....	10
外形尺寸	
Outline Dimensions.....	11
包装	
Packaging.....	12
焊接指导	
Guideline for Soldering.....	14
使用注意事项	
Precautions.....	16

电性参数

Electrical Characteristics

最大额定值（如无特殊说明， $T_A = 25^\circ\text{C}$ ， $V_{SS} = 0\text{V}$ ）

参数 Parameter	符号 Symbol	范围 Range	单位 Units
供电电压 Supply Voltage	Vdd	-0.5 ~ 5.5	V
白光输出端口耐压 White light output port withstand voltage	Vout	12	V
逻辑输入电压 Logic input voltage	Vi	-0.5 ~ Vdd + 0.5	V
工作温度 Operating Temperature Range	Topt	-40 ~ +85	°C
储存温度 Operating Temperature Range	Tstg	-20 ~ +60	°C
湿气敏感等级 Moisture sensitive level	MSL	5a	-
ESD 耐压 (HBM) ESD WITHSTAND VOLTAGE (HBM)	V_{ESD}	2K	V

推荐工作范围（如无特殊说明， $T_A = 25^\circ\text{C}$ ， $V_{DD} = 5\text{V}$ ）

参数 Parameter	符号 Symbol	最小 Min.	典型 Typ.	最大 Max.	单位 Units
供电电压 Supply Voltage	VDD	3.5	5	5.5	V
工作温度 Operating temperature	Ta	-30	-	70	°C

电气参数（如无特殊说明， $T_A = -40 \sim +85^\circ\text{C}$ ， $V_{SS} = 0\text{V}$ ， $V_{DD} = 4.5 \sim 5.5\text{V}$ ）直流参数（除非特别说明， $V_{DD} = 5\text{V}$ ， $T_A = 25^\circ\text{C}$ ）

参数 Parameter	符号 Symbol	最小 Min.	典型 Typ.	最大 Max.	单位 Units
工作电流 Operating Current	I _{DD}	-	0.5	-	mA
白光驱动电流 White light drives current	I _{LED}	-	12	-	mA
DI 高电平输入 Di High level input	V _{IH}	0.65V _{DD}	-	-	V
DI 低电平输入 Di Low level input	V _{IL}	-	-	0.3V _{DD}	V

交流参数 (除非特别说明, VDD=5V, Ta=25°C)

参数 Parameter	符号 Symbol	最小 Min.	典型 Typ.	最大 Max.	单位 Units	测试条件 Test Condition
数据传输速度 Data transfer speed	f _{DATA}	-	800	-	kHz	
白光端口的 PWM 频率 White Light PORT PWM frequency	f _{PWM}	-	1.5	-	kHz	
数据转发传输延迟 Data forward transmission delay	t _{PLH}	-	0.21	-	us	DI → DO 信号延时 DO 端口对地负载电 30pF
	t _{PHL}	-	0.21	-	us	
DO 电平转换时间 Do level transition time	t _{TLH}	-	0.018	-	us	DO 端口对地负载电 30pF
	t _{THL}	-	0.018	-	us	
白光端口电平转换时间(注 1) White Light Port Level Conversion Time (Note 1)	t _r	-	0.15	-	us	I _{LED} =12mA
	t _f	-	0.40	-	us	

注 1: 为了减白光端口的开关对电源电压的冲击, *t_r/t_f* 比较缓慢, 不影响点亮。

Note 1: To reduce the impact of RGB port switches on the supply voltage, TR/TF is slow and does not affect the lighting.

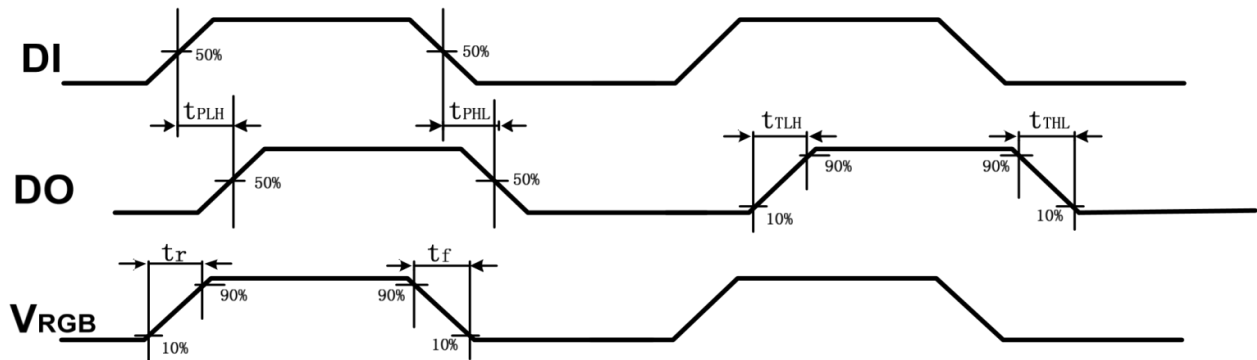

注 2: 交流参数示意图

Note 2: Schematic Diagram of the AC parameters

内置 LED 参数/Built-in LED parameters:

发光颜色 Luminous color	色温 (K) Color Temperature (K)	发光强度 (mcd) Luminous Intensity (mcd)	工作电流 (mA) Operating Current (mA)	测试条件 Test Condition
WW	5500-7000	4000-8000	12*3	DC5V

功能说明/Description of functions:

5050 内封 IC 灯珠采用单线通讯方式，采用归零码的方式发送信号。芯片在上电复位以后，接收 DIN 端打来的数据，接收够 24bit 后，DO 端口开始转发数据，供下一个芯片提供输入数据。在转发之前，DO 口一直拉低。此时灯珠将不接收新的数据，内置白光芯片根据接收到的 24bit 数据后产生的不同占空比信号，展现不同亮度。如果 DIN 端输入信号为 RESET 信号，芯片将接收到的数据送显示，芯片将在该信号结束后重新接收新的数据，在接收完开始的 24bit 数据后，通过 DO 口转发数据，灯珠在没有接收到 RESET 码前，白光亮度保持不变，当接收到 80us 以上低电平 RESET 码后，灯珠内部白光芯片将根据刚才接收到的 24bit 数据后产生的不同占空比信号，展现不同亮度。

The 5050 INNER-SEALED IC lamp ball adopts the single-line communication mode, and uses the return-to-zero code mode to send the signal. After the power-on reset, the chip receives the data from the Din terminal. After receiving enough 24 bits, the DO port begins to forward the data for the next chip to provide input data. Do Mouth is pulled down until forwarding. At this time the bead will not receive new data, the built-in white chip according to the 24-bit data received after the generation of different duty cycle signals, showing different brightness. If the DIN input signal is a RESET signal, the chip will receive the data display, the chip will receive the new data at the end of the signal, after receiving the beginning of the 24-bit data, data transmission through the DO port, when the low-level RESET code above 80us is received, the white light chip inside the bulb will display different brightness according to the different duty cycle signal generated by the 24bit data just received.

1) 芯片级联方法/Chip cascading method:

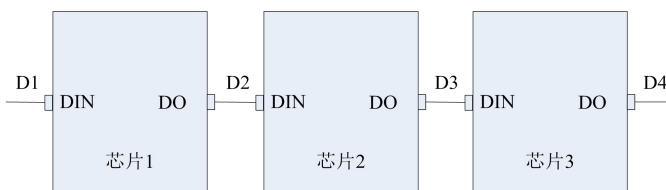

2) 数据传输/Data transmission:



注：其中 D1 为 MCU 端发送的数据，D2、D3、D4 为级联电路自动整形转发的数据。

Note: Where D1 is the data sent by the MCU, D2, D3, and D4 are the data automatically transferred by the cascading circuit.

3) 24bit 数据结构/24 bit data structure:

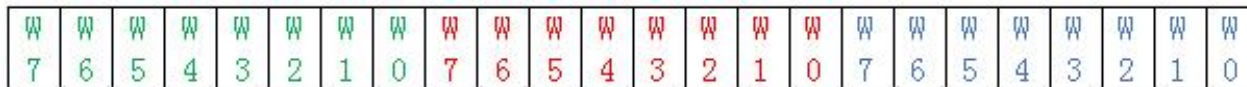

注：高位先发。

Note: Higher-level starts.

4) 时序波形图/Sequential wave map:

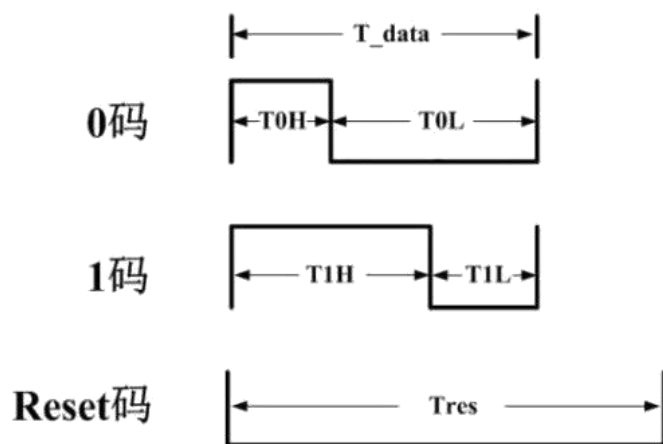

5) 控制器发送码型要求/Controller Transmit Code type requirements:

参数 Parameter	符号 Symbol	最小值 MIN.	典型值 Typ.	最大值 Max	单位 Units
码元周期 Code period	T _{DATA}	1.2	1.25	-	us
0 码高电平时间 Zero Yard high-level time	T _{0H}		0.25	0.47	us
0 码低电平时间 Zero Yard low level time	T _{0L}		1		us
1 码高电平时间 One Yard high level time	T _{1H}	0.58	0.85	1	us
1 码低电平时 One Yard low level time	T _{1L}		0.4		us
Reset 码低电平时间 Reset Code Low level time	T _{res}	80			us

注：控制器发送数据 “0”码高电平时间必须小于 **0.47us**；数据 “1”码高电平时间必须大于 **0.58us**。

Note: Controller Must Send Data “0” Code High Level Time is less than 0.47 US; data “1” Code high level time is more than 0.58 us.

应用线路图/Application Route Diagram:

电源电压 5V (如下图示) /Power supply voltage 5V (as shown)

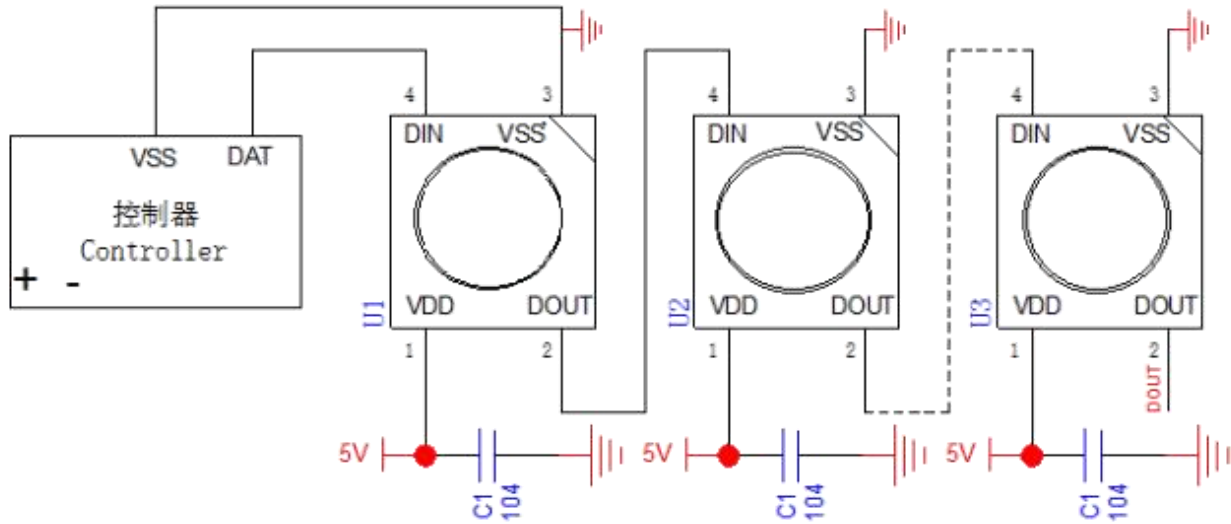

注/Note:

1. 在走线时, 应避免电源线、地线走线过细;

In the line, should avoid the power cord, the ground wire too fine.

2. 产品应用中驱控灯珠级联数量及控制器参数配置、驱动电源品质均有较大差异, 故请在批量使用产品前, 客户方务必自行验证产品兼容性, 我司不承诺满足客户所有应用需求.

In the application of the product, there are big differences in the number of the cascade of the driving lights, the configuration of the controller parameters and the quality of the driving power, we are not committed to meeting all the application requirements of our customers.

典型特性曲线

Typical Characteristics Curves

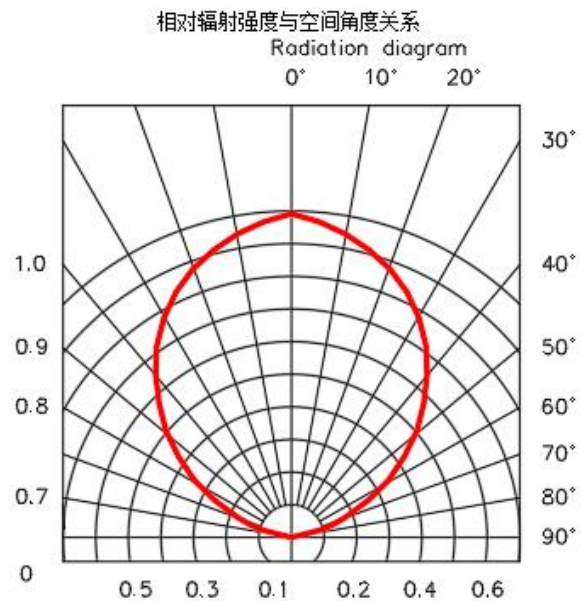
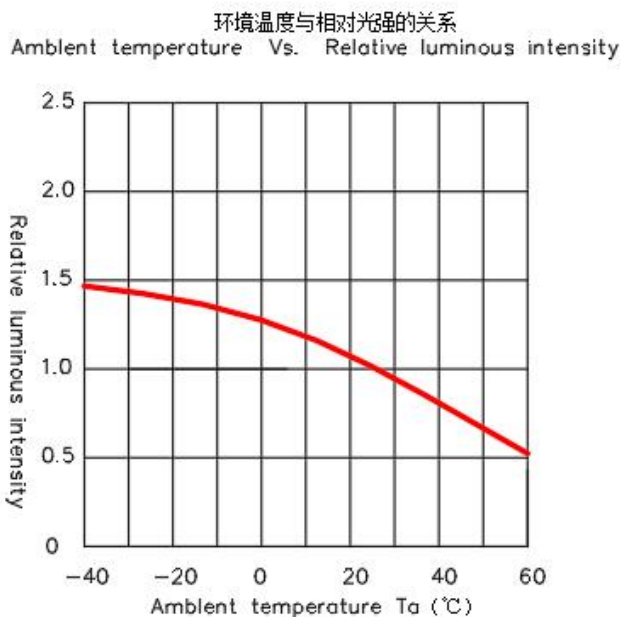
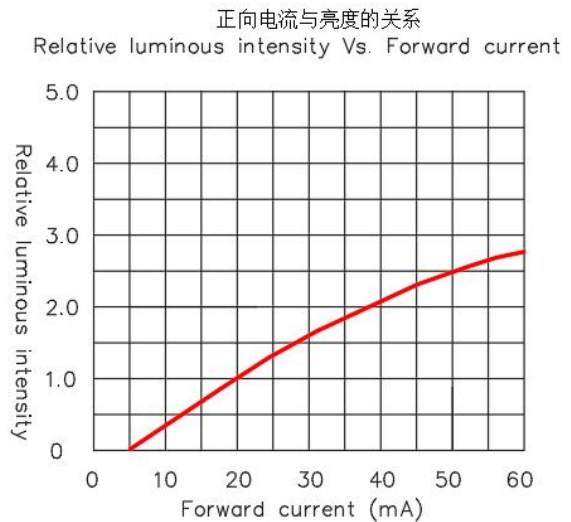
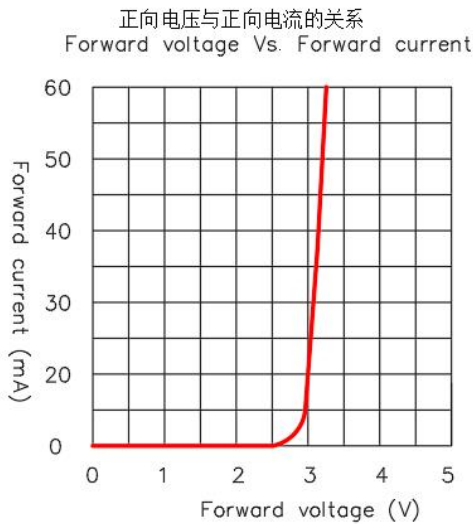
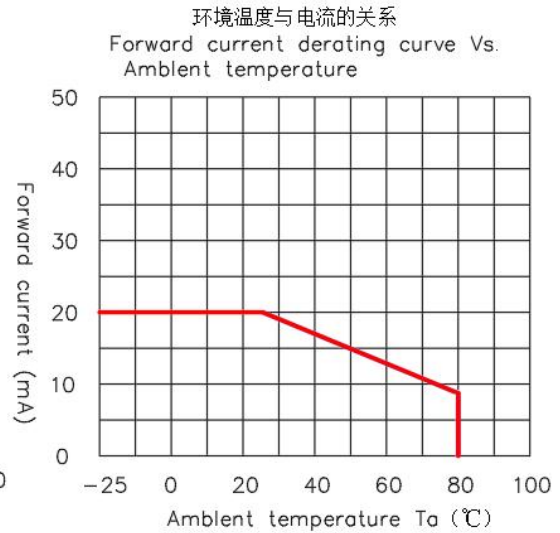
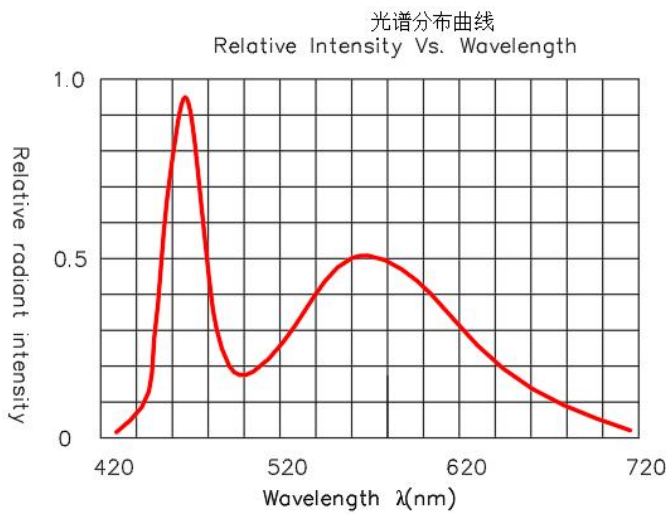

*可靠性实验项目 Reliability Test Project

描述 Description	项目 Item	测试标准 Test criterion	测试条件 Test condition	测试时间 Testtime	数量 Qty	失效数量 Fail qty
寿命测试 Life test	常温寿命测试 Life test(room temperature)	JIS7021:B4	Ta=25°C±5°C, IF=20mA	1000Hrs	22	0
环境测试 Ambience test	高温存储 High temperature store	JIS7021:B10 MIL-STD-202:210A MIL-STD-750:2031	Ta=85°C±5°C	1000Hrs	22	0
	低温存储 Low temperature store	JIS7021:B12	Ta=-35°C±5°C	1000Hrs	22	0
	高温高湿测试 High temperature/ humidity test	JIS7021:B11 MIL-STD-202:103D	Ta=85°C±5°C RH=85%	1000Hrs	22	0
	冷热冲击测试 Cold / Heat strike test	JIS7021::B4 MIL-STD-202:107D MIL-STD-750:1026	30min -10°C±5°C←→100°C± 5°C 5min 5min	50Cycles	22	0
	冷热循环测试 Cold and heat cycle test	JIS7021:A3 MIL-STD-202:107D MIL-STD-705:105E	5min 5min 5min -35°C~25°C~85°C~ -35°C 30min 5min 30min 5min	50Cycles	22	0

*判断标准 Judging criterion:

项目 Item	符号 Symbol	实验条件 Experiment condition	判断标准 Criteria	
			Min.	Max.
Forward Voltage 正向电压	VF	IF=36mA	----	Initial Datex1.1
Reverse Current 反向电流	IR	VR=5V	----	5 μ A
Luminous Intensity 发光强度	IV	IF=36mA	Initial Datex0.7	----

外形尺寸

Outline Dimension

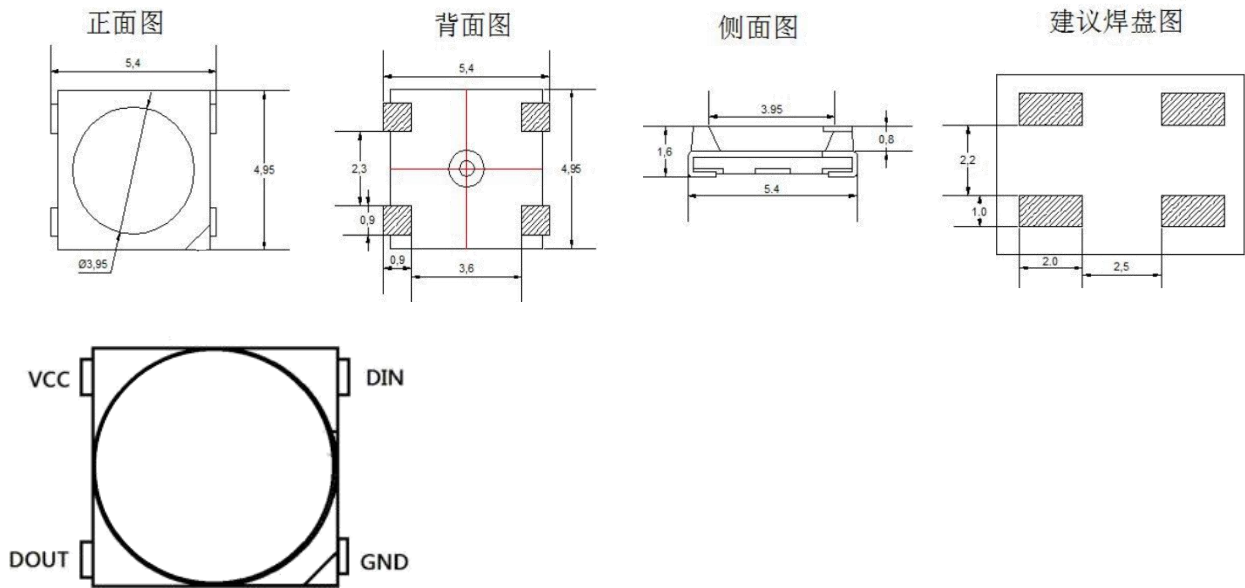

备注： 1. 以上尺寸单位均为 mm

Remarks: All dimensions are in millimeters.

2. 未特别标注公差尺寸公差均为 $\pm 0.25\text{mm}$

Tolerance is $\pm 0.25\text{mm}$ unless otherwise noted

引脚电路图及引脚功能:

序号 Serial number	符号 Symbol	功能描述 Function description
1	VCC/VDD	内部 IC 电源正及白光正极 INTERNAL IC power supply and white light positive electrode
2	DOUT	显示数据级联输出 (800K) Display data cascade output (800K)
3	GND/VSS	信号地及电源地 Signal ground and power supply ground
4	DIN	显示数据输入 (800K) Display data input (800K)

包装 (1)

Packaging (1)

载带与圆盘尺寸 Belt and disk dimensions

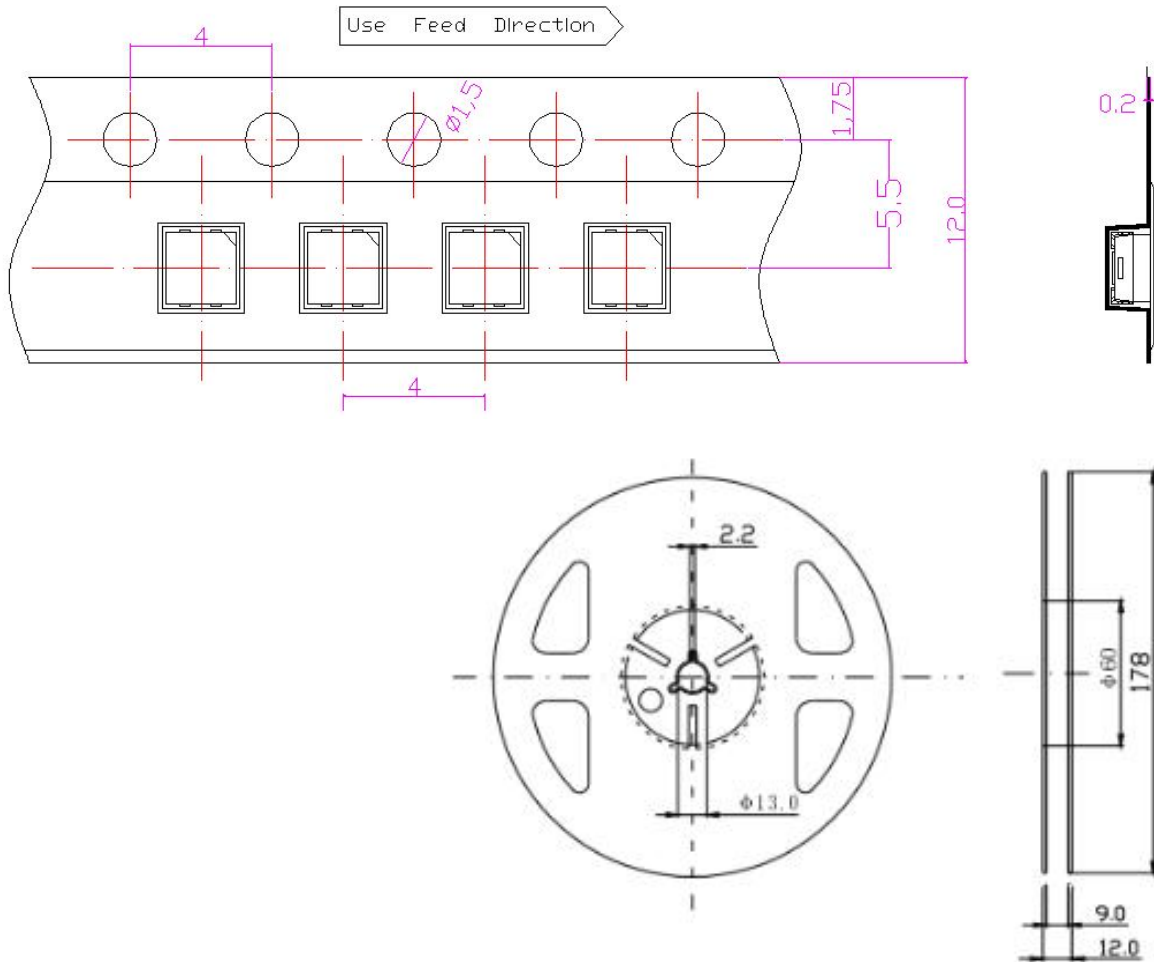

备注： 1. 以上尺寸单位均为 mm

Remarks: All dimensions are in millimeters.

2. 未特别标注公差尺寸公差均为 $\pm 0.25\text{mm}$

Tolerance is $\pm 0.25\text{mm}$ unless otherwise noted

◇ 圆盘及载带卷出方向及空穴规格 Disk and carrier belt direction of roll and hole dimensions

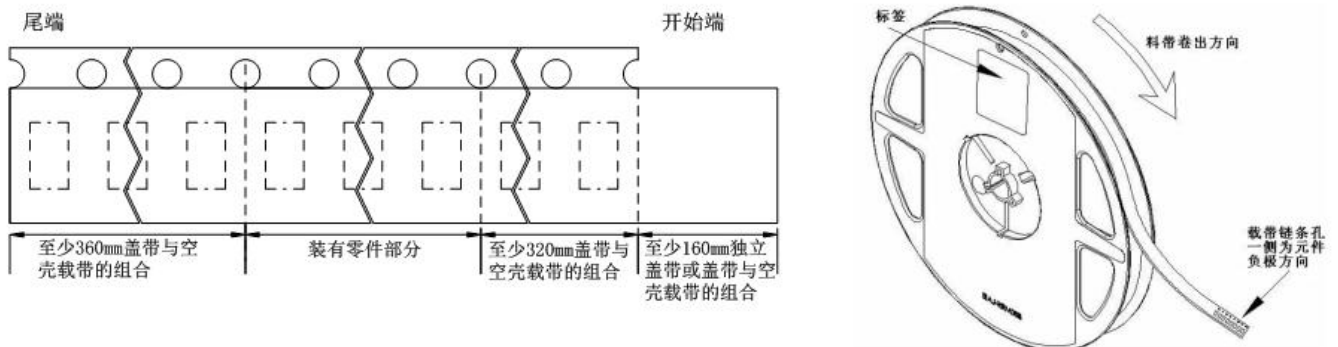

包装 (2)

Packaging (2)

◇ 防潮防静电包装 Moisture Proof and Anti-Electrostatic Foil Bag

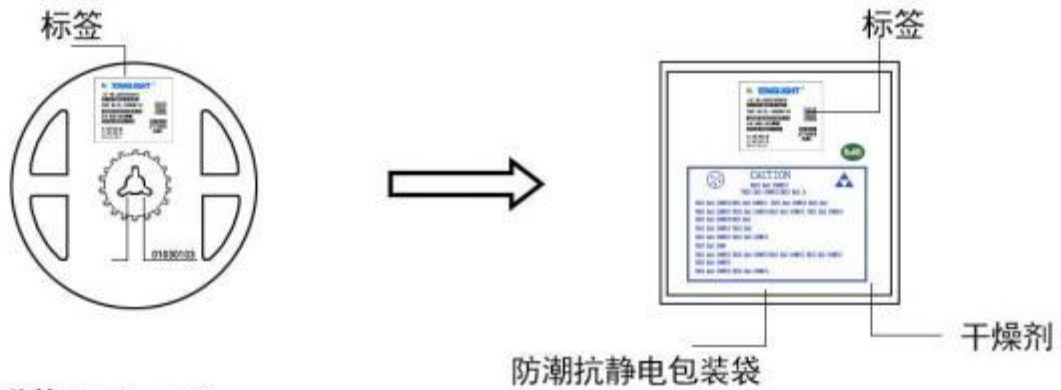

◇ 外包装箱 Cardboard Box

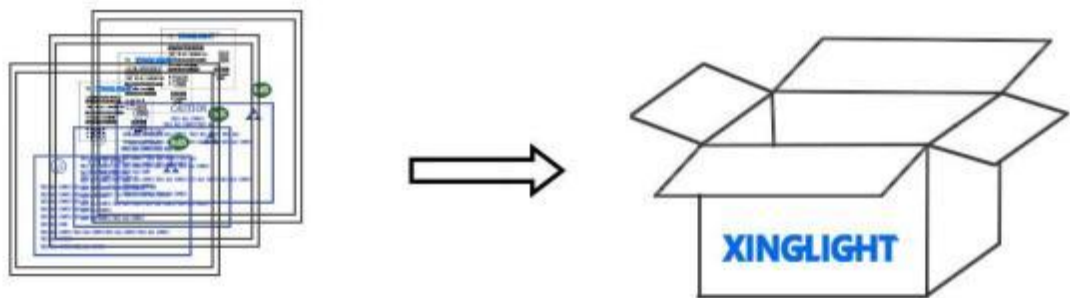

Capacity 5 or 10 reels per box (内箱容量: 50或100卷)

◇ 标签说明: Label Explanation

- LOT NO: 批次信息
- PART NO: 产品型号
- BIN CODE: 产品名称
- WL: 波长范围
- IV: 光强范围
- VF: 电压范围



焊接指导 (1)

Guideline for Soldering (I)

1. 使用烙铁人手焊接

Hand Soldering

只建议在修理和重工的情况下使用手工焊接；推荐使用功率低于 30 W 的烙铁，焊接时烙铁的温度必须保持在 300℃ 以下，且每个电极只能进行一次焊接，每次焊接的持续时间不得超过 3 秒。

人手焊接过程中的不慎操作易引起 LED 产品的损坏，应当小心谨慎。

Manual welding is recommended only for repair and heavy industry situations. A soldering iron of less than 30W is recommended to be used in Hand Soldering. Please keep the temperature of the soldering iron under 300°C while soldering. Each terminal of the LED is to go for less than 3 second and for one time only.

Be careful because the damage of the product is often started at the time of the hand soldering.

2. 回流焊接： 推荐使用以下无铅回流焊接温度图进行。

Reflow Soldering: Use the conditions shown in the under Figure of Pb -Free Reflow Soldering.

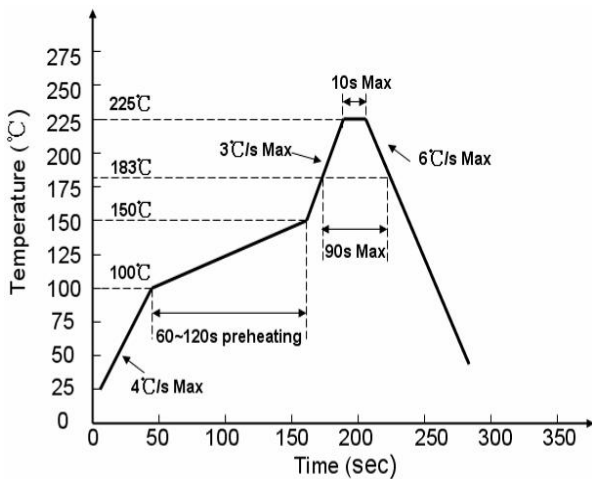

有铅制程 Lead process

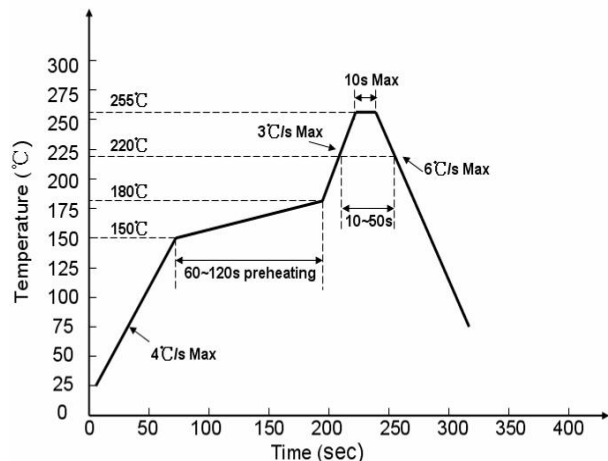

无铅制程 lead free

回流焊接最多只能进行两次。

Reflow soldering should not be done more than two times.

在回流焊接升温过程中，请不要对 LED 施加任何压力。

Stress on the LEDs should be avoided during heating in soldering process.

在焊接完成后，待产品温度下降到室温之后，再进行其他处理。

After soldering, do not deal with the product before its temperature drop down to room temperature.

焊接指导 (2)

Guideline for Soldering (2)

3. 清洗:

Cleaning

在焊接后推荐使用酒精进行清洗，在温度不高于 30°C 的条件下持续 3 分钟，不高于 50°C 的条件下持续 30 秒。

使用其他类似溶剂清洗前，请先确认使用的溶剂不会对 LED 的封装和环氧树脂部分造成损伤。超声波清洗也是有效的方法，一般最大功率不应超过 300W，否则可能对 LED 造成损伤。请根据具体的情况预先测试清洗条件是否会对 LED 造成损伤。

It is recommended that alcohol be used as a solvent for cleaning after soldering. Cleaning is to go under 30°C for 3 minutes or 50°C for 30 seconds. When using other solvents, it should be confirmed beforehand whether the solvents will dissolve the package and the resin or not.

Ultrasonic cleaning is also an effective way for cleaning. But the influence of Ultrasonic cleaning on LED depends on factors such as ultrasonic power. Generally, the ultrasonic power should not be higher than 300W. Before cleaning, a pretest should be done to confirm whether any damage to LEDs will occur.

*** 注意：** 此一般指导原则并不适用于所有 PCB 设计和焊接设备的配置。具体工艺受到诸多因素的影响，请根据特定的 PCB 设计和焊接设备来确定焊接方案。

*** Note:** This general guideline may not apply to all PCB designs and configurations of all soldering equipment. The technics in practise is influenced by many factors, it should be specialized base on the PCB designs and configurations of the soldering equipment..

使用注意事项 (1)

Precautions (1)

1. 贮存:

Storage

- 本产品使用密封防潮抗静电袋包装，并附有干燥剂，未开封的产品有一年的保存时间。

Moisture proof and anti-electrostatic package with moisture absorbent material is used, to keep moisture to a minimum.

- 开封前，产品须存放在温度不高于 30℃，湿度不高于 60%RH 的环境中。

Before opening the package, the product should be kept at 30℃ or less and umidity less than 60% RH, and be used within a year.

- 开封后，产品须存放在温度不高于 30℃，湿度不高于 10%RH 的环境中，且应该在 168 小时（7 天）内使用完。建议工作环境为温度不高于 30℃，湿度不高于 60%RH。

After opening the package, the product should be stored at 30℃ or less and humidity less than 10%RH, and be soldered within 168 hours (7 days). It is recommended that the product be operated at the workshop condition of 30℃ or less and humidity less than 60%RH.

- 对于尚未焊接的 LED，如果吸湿剂或包装失效，或者产品没有符合以上有效存储条件，烘焙可以起到一定的性能恢复效果。烘焙条件：60±5) °C，持续24 小时。

If the moisture absorbent material has fade away or the LEDs have exceeded the storage time, baking treatment should be performed based on the following condition: (60±5)°C for 24 hours.

2. 静电:

Static Electricity

静电和电涌会导致产品特性发生改变，例如正向电压降低等，如果情况严重甚至会损毁产品。所以在使用时必须采取有效的防静电措施。所有相关的设备和机器都应该正确接地，同时必须采取其他防止静电和电涌的措施。使用防静电手环，防静电垫子，防静电工作服、工作鞋、手套，防静电容器，都是有效的防止静电和电涌的措施。

Static electricity or surge voltage damages the LEDs. Damaged LEDs will show some unusual characteristic such as the forward voltage becomes lower, or the LEDs do not light at the low current. even not light.

All devices, equipment and machinery must be properly grounded. At the same time, it is recommended that wrist bands or anti-electrostatic gloves, anti-electrostatic containers be used when dealing with the LEDs.

使用注意事项 (2)

Precautions (2)

3. 设计建议:

Design Consideration

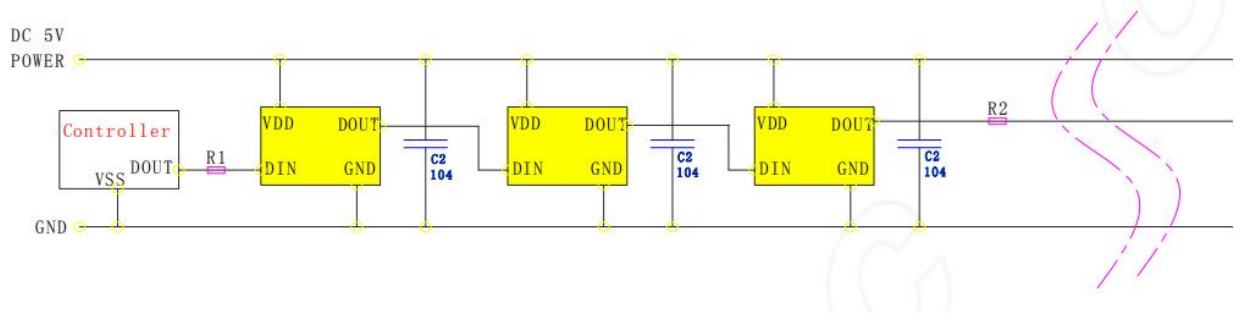

在实际应用电路中,为防止产品在测试时带电插拔产生的瞬间高压损伤 IC 内部电源及 信号输入输出脚,应在信号输入及输出端串接保护电阻。此外,为了使各 IC 芯片间更 稳定工作,各灯珠间的退偶电容则必不可少;

1. 产品两端所并的退偶电容一般不建议省略;
2. 产品的信号输入及输出端必需串接保护电阻 R1/R2, 因线材及传输距离不同, 在信号线两端串接的保护电阻会略有不同; R1/R2 的大小取决于级联灯珠的数量, 级联数量越多, 则 R1/R2 越小, 灯珠间传输距离长, 一般建议在 20-2K Ω 之间取值, 建议通常建议取值 在 500 欧左右; 以实际使用情况定; R2 可接地。

In practical application circuits, To prevent instantaneous high voltage generated by live plugging during product testing Damage to IC internal power supply and signal input/output pins Protective resistors should be connected in series at the signal input and output terminals .In addition, in order to ensure more stable operation between IC chips The decoupling capacitance between each lamp bead is essential:

- 1、 It is generally not recommended to omit the decoupling capacitors connected at both ends of the pr... ;
- 2、 The signal input and output terminals of the product must be connected in series with protective r...; Due to differences in wire material and transmission distance; The size of r1/r2 depends on the number of cascaded lamp beads , The more cascades, the smaller r1/r2 ; Long transmission distance between lamp beads , Generally recommended between 20-2k ω Value between , The recommended value is usually around 500 euros; Based on actual usage; R2 can be grounded .

使用注意事项 (3)

Precautions (3)

4. 其他事项:

Others

直接用手拿取产品不但会污染封装树脂表面,也可能由于静电等因素导致产品性能的改变。过度的压力也可能直接影响封装内部的管芯和金线,因此请勿对产品施加过度压力,特别当产品处于高温状态下,例如在回流焊接过程中。

When handling the product, touching the encapsulant with bare hands will not only contaminate its surface, but also affect on its optical characteristics. Excessive force to the encapsulant might result in catastrophic failure of the LEDs due to die breakage or wire deformation. For this reason, please do not put excessive stress on LEDs, especially when the LEDs are heated such as during Reflow Soldering.

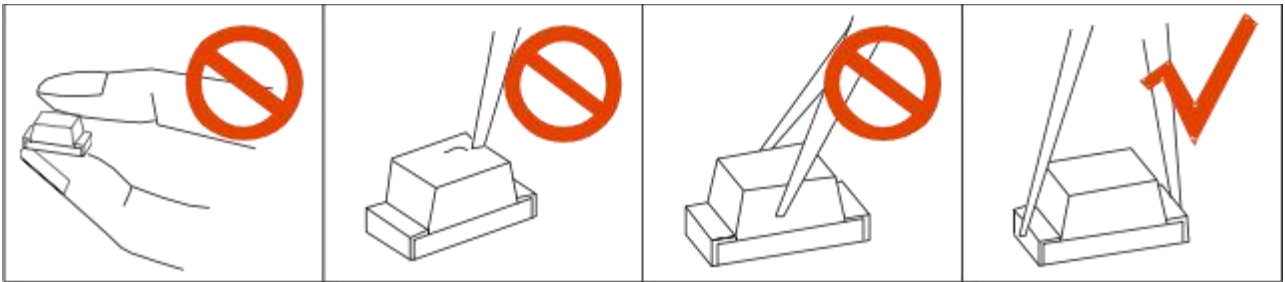

LED 的环氧树脂封装部分相当脆弱,请勿用坚硬、尖锐的物体刮、擦封装树脂部分。在用镊子夹取的时候也应当小心注意。

The epoxy resin of encapsulant is fragile, so please avoid scratch or friction over the epoxy resin surface.

While handling the product with tweezers, do not hold by the epoxy resin, be careful.

5. 眼睛保护忠告:

Safety Advice For Human Eyes

LED 发光时,请勿直视发光光源,特别是对于一些光强较高的 LED,强光可能伤害你的眼睛。

Viewing direct to the light emitting center of the LEDs, especially those of great Luminous Intensity, will cause great hazard to human eyes. Please be careful.