

# CERAMIC RESONATORS (CERALOCK®)

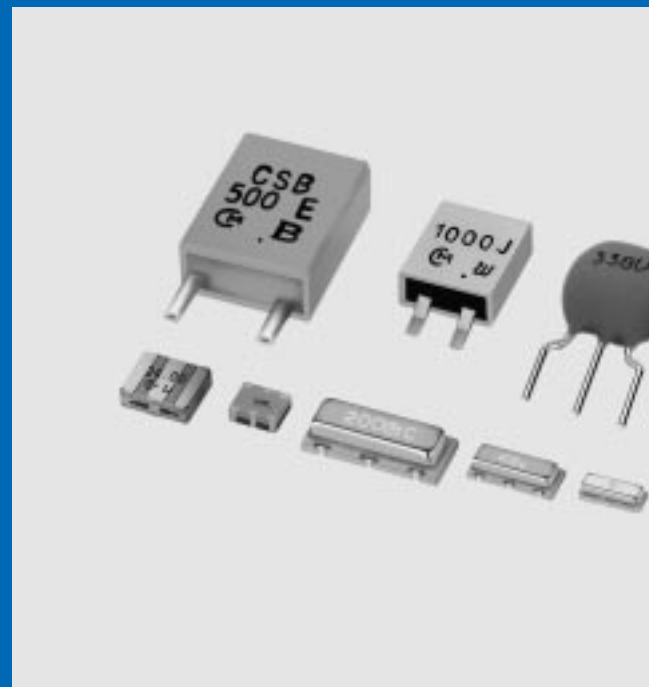

**muRata** *Innovator  
in Electronics*

Murata  
Manufacturing Co., Ltd.

<b>Part Numbering</b>	2
<b>1 Chip Type Three-Terminals CSTCC/E/G/R/V/W Series</b>	3
<b>2 Chip Type Two-Terminals CSACV/W Series</b>	7
<b>MHz Chip Type Notice</b>	9
<b>MHz Chip Type CSTC Series Packaging</b>	12
<b>MHz Chip Type CSAC Series Packaging</b>	14
<b>3 Lead Type Three-Terminals CSTLS Series</b>	15
<b>4 Lead Type Two-Terminals CSALS Series</b>	17
<b>MHz Lead Type Notice</b>	19
<b>MHz Lead Type CSTLS Series Packaging</b>	20
<b>MHz Lead Type CSALS Series Packaging</b>	22
<b>5 Chip Type Two-Terminals CSBFB Series</b>	23
● kHz Chip Type CSBFB_J 430-519kHz Notice (Soldering and Mounting)	25
● kHz Chip Type CSBFB_J 700-1250kHz Notice (Soldering and Mounting)	26
<b>6 Lead Type Two-Terminals CSBLA Series</b>	27
<b>kHz Lead Type Notice</b>	29
<b>kHz Type Notice</b>	30
<b>kHz Type Packaging</b>	31
<b>Application Circuits Utilizing</b>	32



Recycled P

(Global Part Number) **CS** **1** **CV** **16M0** **X53** **\*\*\*** **-R0**

① ② ③ ④ ⑤ ⑥ ⑦

① Product ID

Product ID	
<b>CS</b>	Ceramic Resonators

② Frequency/Capacitance

Code	Frequency/Capacitance
<b>A</b>	MHz No capacitance built-in
<b>T</b>	MHz Built-in Capacitance

③ Structure/Size

Code	Structure/Size
<b>LA</b>	Lead Type
<b>LS</b>	Round Lead Type
<b>CC</b>	Cap Chip Type
<b>CR/CE/CG</b>	Small-cap Chip Type
<b>CV</b>	Monolithic Chip Type
<b>CW</b>	Small Monolithic Chip Type

④ Nominal Center Frequency

Expressed by four-digit alphanumerics. The unit is in hertz (MHz). Decimal point is expressed by capital letter "M".

⑤ Design

Code	Design
<b>G□□</b>	Thickness Shear mode
<b>T/V□□</b>	Thickness Expander mode
<b>X□□</b>	Thickness Expander mode (3rd overtone)

□□ indicates initial frequency tolerance and load capacity.

CERALOCK® (kHz)

(Global Part Number) **CS** **B** **FB** **1M00** **J58** **\*\*\*** **-R1**

① ② ③ ④ ⑤ ⑥ ⑦

① Product ID

Product ID	
<b>CS</b>	Ceramic Resonators

② Frequency/Capacitance

Code	Frequency/Capacitance
<b>B</b>	kHz No capacitance built-in

③ Structure/Size

Code	Structure/Size
<b>LA</b>	Two-Terminal Lead Type
<b>FB</b>	SMD Type

④ Nominal Center Frequency

Expressed by four-digit alphanumerics. The unit is in hertz (Hz). Capital letter "K" following three figures expresses the unit of "kHz".

⑥ Individual Specification

Code	Individual Specification
<b>***</b>	Three-digit alphanumerics express "Individual Specification".

With standard products, "⑥ Individual Specification" is omitted, and "⑦ Package Specification Code" is carried up.

⑦ Packaging

Code	Packaging
<b>-B0</b>	Bulk
<b>-A0</b>	Radial Taping H <sub>0</sub> =18mm
<b>-A1</b>	Radial Taping H <sub>0</sub> =16mm
<b>-R0</b>	Plastic Taping ø=180mm
<b>-R1</b>	Plastic Taping ø=330mm

Radial taping is applied to lead type and plastic taping to chip type.

⑤ Design

Code	Design
<b>E□□</b>	Area Expansion mode
<b>J□□</b>	Area Expansion mode (Closed Type)

□□ indicates initial frequency tolerance and load capacitance.

⑥ Individual Specification

Code	Individual Specification
<b>***</b>	Three-digit alphanumerics express "Individual Specification".

With standard products, "⑥ Individual Specification" is omitted, and "⑦ Package Specification Code" is carried up.

⑦ Packaging

Code	Packaging
<b>-B0</b>	Bulk
<b>-R1</b>	Plastic Taping ø=330mm

Chip "CERALOCK" with built-in load capacitance in an extremely small package.

MURATA's package technology expertise has enabled the development of the Chip "CERALOCK" with built-in load capacitors.

High-density mounting can be realized because of the small package and the elimination of the need for an external load capacitor.

### ■ Features

1. Oscillation circuits do not require external load capacitors.
2. The series is available in a wide frequency range.
3. The resonators are extremely small and have a low profile.
4. No adjustment is necessary for oscillation circuits.

### ■ Applications

- Clock oscillators for microprocessors.
- Electronic control circuits for small electronic equipment such as hand held movie.
- Audio-visual applications (Camcorder, Remote Controller, etc.)
- Office automation equipments (DVD, CD-ROM, HDD, FDD, etc.)
- Automotive electronics. (CSTCC\_G\_A series, CSTCR\_G\_A series, CSTCE\_G\_A series, CSTCV\_X\_Q series)
- Dual Tone Multi Frequency (DTMF) generator for cordless telephones.



CSTCC\_G(A)  
2.00-3.99MHz

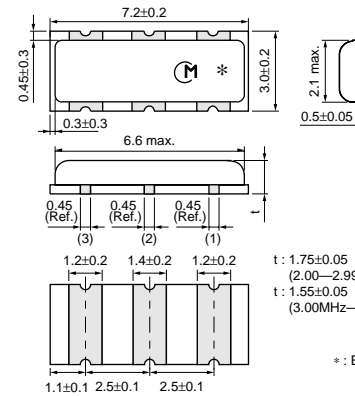

CSTCR\_G(A)  
4.00-7.99MHz

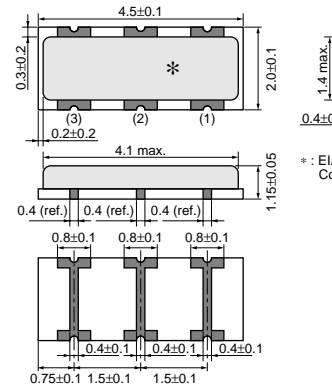

CSTCE\_G(A)  
8.00-12.50MHz

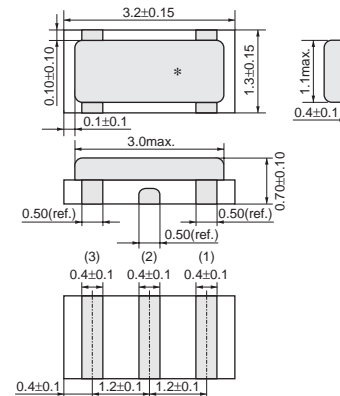

CSTCE\_V  
12.51-19.99MHz

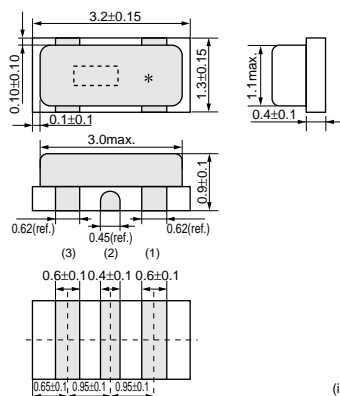

(in mm)



CSTCV\_X\_Q  
14.70-70.00MHz

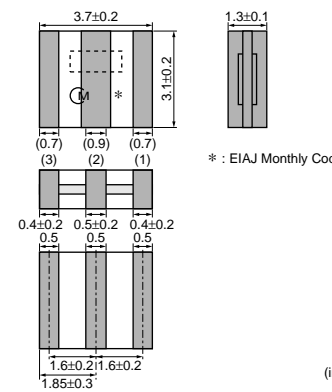

\* : EIAJ Monthly Cod

Continued on the following page



CSTCW\_X  
20.00-70.00MHz

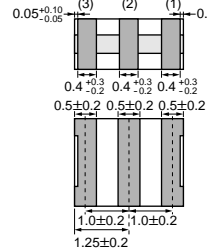

Thickness varies with frequency and built-in capacitors value.  
\*: EIAJ code

(in mm)

CSTCG\_V  
20.00-33.86MHz  
(Ultra small)

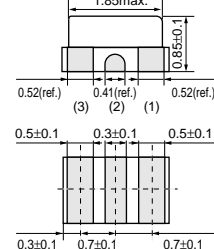

Part Number	Oscillating Frequency (MHz)	Initial Tolerance (%)	Temp.Stability (%)	Temperature Range (°C)	Aging (10 years) (%)	Use
CSTCC_G	2.00 to 3.99	±0.5	±0.3	-20 to 80	±0.3	For consumer elect
CSTCC_G_A	2.00 to 3.99	±0.5	±0.4	-40 to 125	±0.3	For automotive elec
CSTCR_G	4.00 to 7.99	±0.5	±0.2	-20 to 80	±0.1	For consumer elect
CSTCR_G_A	4.00 to 7.99	±0.5	±0.3	-40 to 125	±0.1	For automotive elec
CSTCE_G	8.00 to 12.50	±0.5	±0.2	-20 to 80	±0.1	For consumer elect
CSTCE_G_A	8.00 to 12.50	±0.5	±0.2	-40 to 125	±0.1	For automotive elec
CSTCE_V	12.51 to 19.99	±0.5	±0.3	-20 to 80	±0.3	For consumer elect
CSTCV_X_Q	14.70 to 70.00	±0.5	±0.3	-40 to 125	±0.1	For automotive elec
CSTCG_V	20.00 to 33.86	±0.5	±0.3	-20 to 80	±0.3	Ultra small typ
CSTCW_X	20.00 to 70.00	±0.5	±0.2	-20 to 80	±0.1	For consumer elect

Irregular or stop oscillation may occur under unmatched circuit conditions. Please check the actual conditions prior to use.

### ■ Oscillation Frequency Measuring Circuit

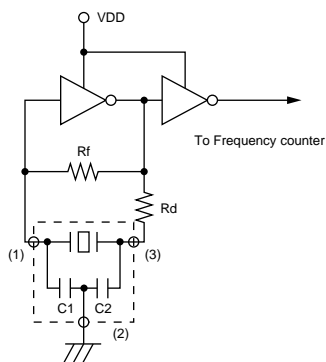

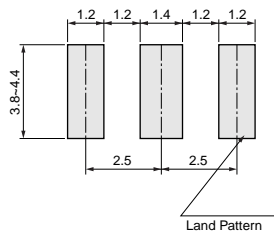

(in mm)

CSTCE\_G(A)

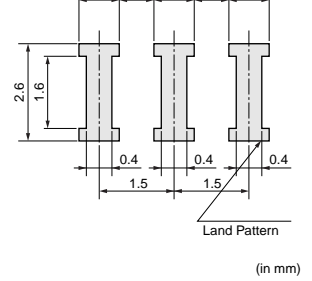

(in mm)

CSTCE\_V

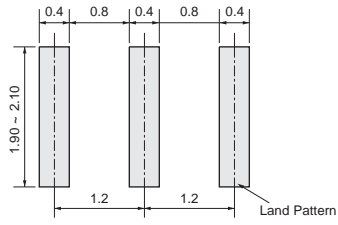

(in mm)

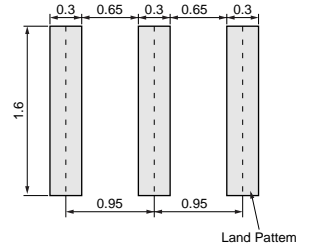

(in mm)

CSTCV\_X\_Q

CSTCG\_V

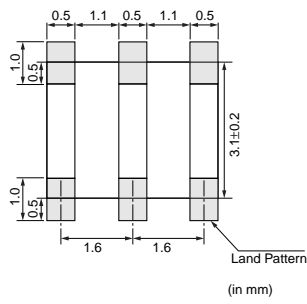

(in mm)

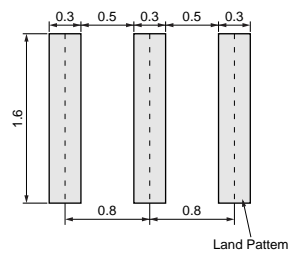

(in mm)

CSTCW\_X

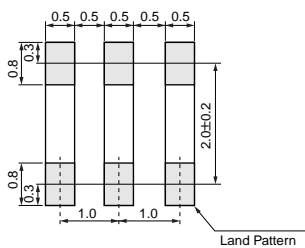

(in mm)



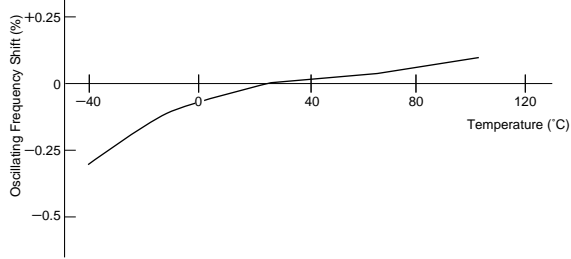

CSTCR\_G(LA)

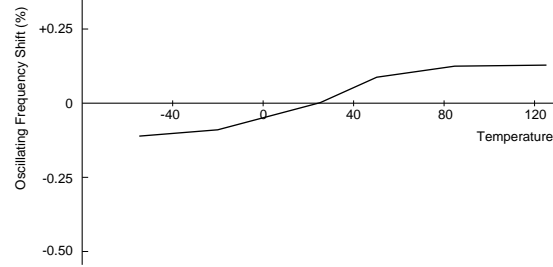

CSTCE\_G(LA)

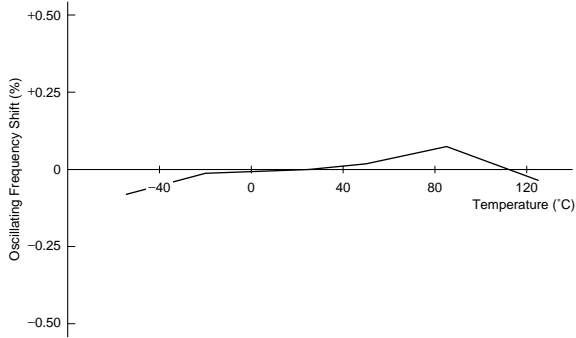

CSTCE\_V

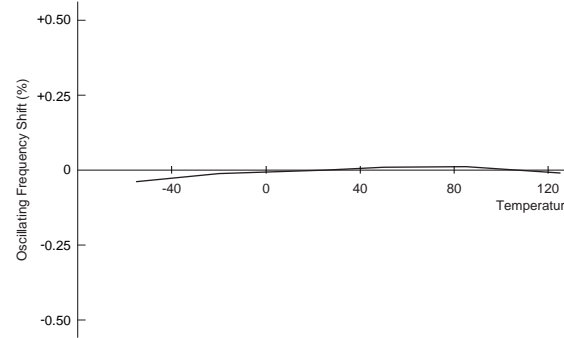

CSTCE\_X(Q)

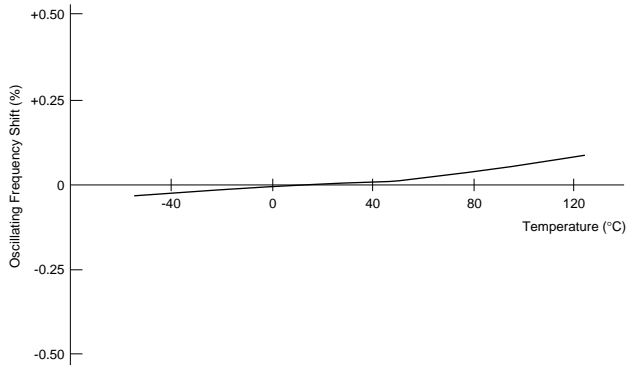

CSTCG\_V

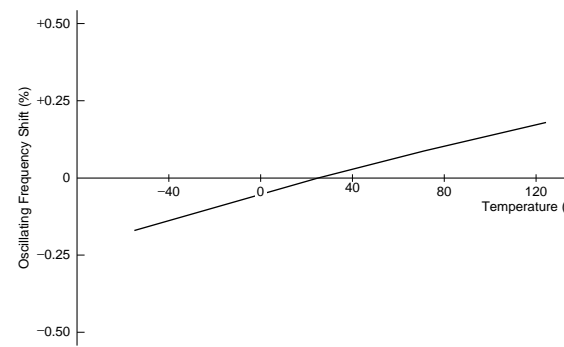

CSTCV\_X(Q)

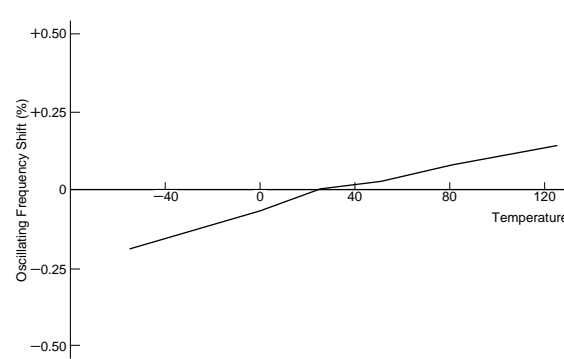
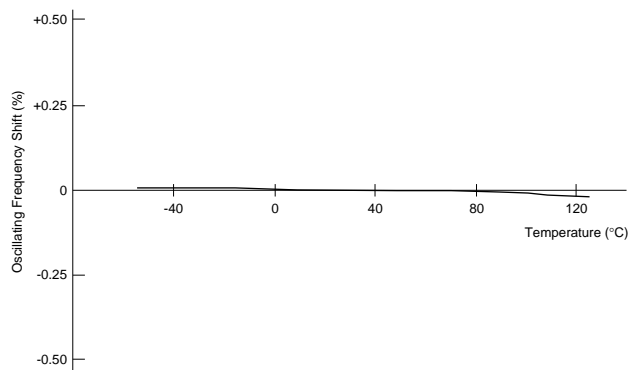

Wide range of chip "CERALOCK" is now available. This diverse series owes its development to MURATA's package technology expertise and original mass production techniques. It enables high-density mounting and further miniaturization of electronic equipment.

■ Features

1. The series is available in a wide frequency range.
2. The resonators are extremely small and have a low profile. (CSACW series)
3. No adjustment is necessary for oscillation circuits.

■ Applications

- Clock oscillators for microprocessors.
- Electronic control circuits for small electronic equipment.
- Automotive electronics. (CSACV\_X\_Q series)



CSACV\_X\_Q  
14.70-70.00MHz

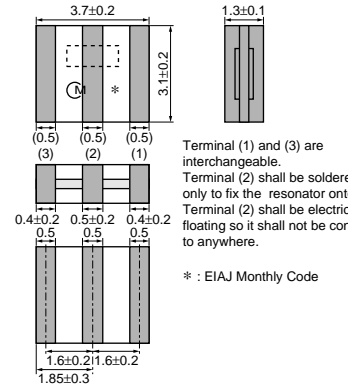

CSACW\_X  
20.00-70.00MHz

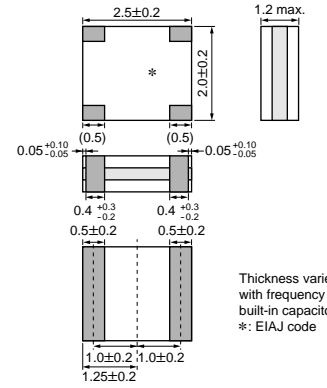

Part Number	Oscillating Frequency (MHz)	Initial Tolerance (%)	Temp.Stability (%)	Temperature Range (°C)	Aging (10 years) (%)	Use
CSACV_X_Q	14.70 to 70.00	±0.5	±0.3	-40 to 125	±0.1	For automotive electronic equipment
CSACW_X_53	20.00 to 24.99	±0.5	±0.2	-20 to 80	±0.1	For consumer electronic equipment
CSACW_X_51	25.00 to 70.00	±0.5	±0.2	-20 to 80	±0.1	For consumer electronic equipment

Irregular or stop oscillation may occur under unmatched circuit conditions. Please check the actual conditions prior to use.

■ Oscillation Frequency Measuring Circuit

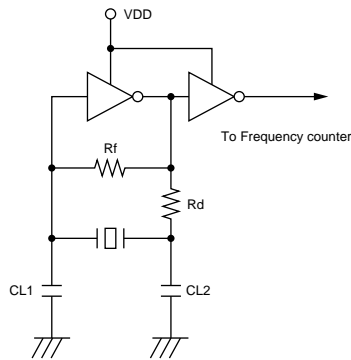



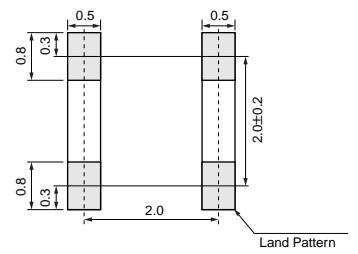
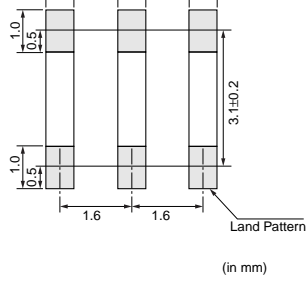

■ Oscillation Frequency Temperature Stability

CSACV\_X\_Q

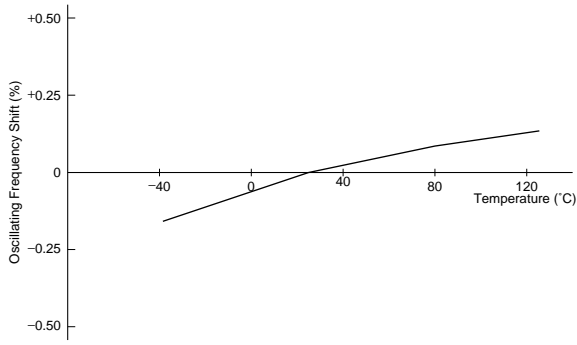

CSACW\_X

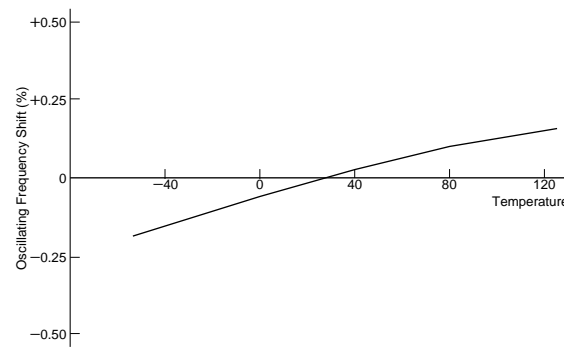

(1) Reflow

One heat stress shown in the right profile is applied to resonator, then being place in natural condition for 1 hour, resonator shall be measure.

1. Pre-heating conditions shall be +140 to +160°C for 60 to 120 seconds. Ascending time up to +150°C shall be longer than 30 second.
2. Heating conditions shall be within 20 seconds at +230°C min., but peak temperature shall be lower than +240°C.

(2) Soldering Iron

Soldering iron of +270±5°C shall be placed 0.5mm above from electrode of resonator. Melting solder through soldering iron shall be applied to electrode for 3±1 seconds, then being place in natural condition for 24 hour, resonator shall be measured.

2. Wash

Some series are not withstand washing. Please check the right list before use.

(1) Cleaning Solvent

HCFC, Isopropanol, Tap water, Demineralized water, Cleanthrough750H, Pine alpha 100S, Techno care FRW

(2) Temperature Difference : dT \*1

dT≤60°C (dT=Component-solvent)

\*1 ex. In case the component at +90°C immerses into cleaning solvent at +60°C, then dT=30°C.

(3) Condition

1. Ultrasonic Wash

1 minute max. in above solvent at +60°C max.  
(Frequency : 28kHz, Output : 20W/L)

2. Immersion Wash

5 minutes max. in above solvent at +60°C max.

3. Shower or Rinse Wash

5 minutes max. in above solvent at +60°C max.

(4) Drying

5 minutes max. by air blow at +80°C max.

(5) Others

1. Total washing time should be within 10 minutes.
2. Please insure the component is thoroughly evaluated in your application circuit.
3. The component may be damaged if it is washed with chlorine, petroleum, or alkali cleaning solvent.

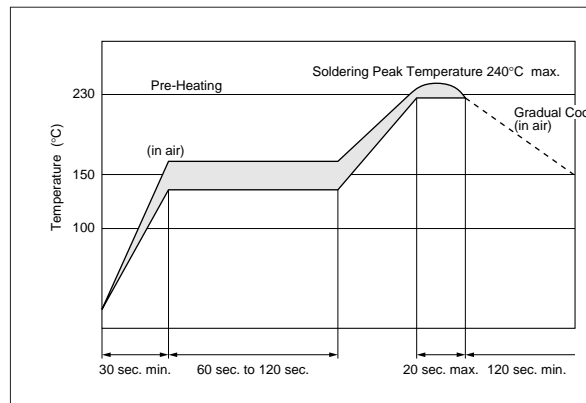

Series	Wash
<b>CSTCC (Except 2.00-3.49MHz)</b>	Available
<b>CSTCV</b>	Available
<b>CSACV</b>	Available
<b>CSTCR</b>	Not Available
<b>CSTCC (Only 2.00-3.49MHz)</b>	Not Available
<b>CSTCW</b>	Not Available
<b>CSACW</b>	Not Available
<b>CSTCE</b>	Not Available
<b>CSTCG</b>	Not Available

\*All automotive types are Available.



#### CSTCC\_G

Please do not apply excess mechanical stress to the component and terminals at soldering.

The component is recommended with placement machines with employ optical placement capabilities.

The component might be resulted in damage by excessivemechanical force. Please make sure that you have evaluated by using placementmachines before going into mass production. Do not use placement machines whichutilize mechanical positioning. Please contact Murata for details beforehand.

#### ■ Notice (Storage and Operating Conditions)

##### CSTCC\_G\_A/CSTCR\_G\_A/CSTCE\_G\_A

Please do not apply excess mechanical stress to the component and terminals at soldering.

Conformal coating of the component is acceptable.

However, the resin material, curing temperature, and other process conditions should be evaluated to confirm stable electrical characteristics are maintained.

The component is recommended with placement machines

#### ■ Notice (Storage and Operating Conditions)

##### CSTCV\_X\_Q/CSACV\_X\_Q

Please do not apply excess mechanical stress to the component and terminals at soldering.

Conformal coating of the component is acceptable.

However, the resin material, curing temperature, and other process conditions should be evaluated to confirm stable electrical characteristics are maintained.

The component is recommended with placement machines

#### ■ Notice (Storage and Operating Conditions)

##### CSTCW\_X/CSACW\_X

Please do not apply excess mechanical stress to the component and terminals at soldering.

Conformal coating or washing to the component is not acceptable. Because it is not hermetically sealed.

#### 1. CSTCC\_G (2.00MHz-3.49MHz)

Conformal coating or washing to the component is not acceptable. Because it is not hermetically sealed.

#### 2. CSTCC\_G (3.50MHz-10.0MHz)

Conformal coating of the component is acceptable. However, the resin material, curing temperature, and other process conditions should be evaluated to confirm stable electrical characteristics are maintained.

with employ optical placement capabilities.

The component might be resulted in damage by excessivemechanical force. Please make sure that you have evaluated by using placementmachines before going into mass production. Do not use placement machines whichutilize mechanical positioning. Please contact Murata for details beforehand.

which employ optical placement capabilities. In some cases, placement machines which utilize mechanical positioning may apply excessive mechanical force which might result in damage to the ceramic resonator. Please contact Murata before mounting this product using placement machines which use mechanical positioning.

CSTCR\_G/CSTCE\_G/CSTCE\_V/CSTCG\_V

Please do not apply excess mechanical stress to the component and terminals at soldering.

Conformal coating or washing to the component is not acceptable. Because it is not hermetically sealed.

The component is recommended with placement machines with employ optical placement capabilities.

The component might be resulted in damage by excessivemechanical force. Please make sure that you have evaluated by using placementmachines before going into mass production. Do not use placement machines whichutilize mechanical positioning. Please contact Murata for details beforehand.

■ Notice (Rating)

The component may be damaged if excess mechanical stress is applied.

■ Notice (Handling)

"CERALOCK" may stop oscillating or oscillate irregularly under improper circuit conditions.



Part Number	Plastic Tape ø180mm	Plastic Tape ø330mm	Bulk	Dimensions
CSTCC_G	2,000	6,000	500	a
CSTCC_G_A	2,000	6,000	500	a
CSTCR_G	3,000	9,000	500	a
CSTCR_G_A	3,000	9,000	500	a
CSTCE_G	3,000	9,000	500	b
CSTCE_G_A	3,000	9,000	500	b
CSTCE_V	3,000	9,000	500	b
CSTCV_X_Q	2,000	6,000	500	a
CSTCW_X	3,000	9,000	500	b
CSTCG_V	3,000	9,000	500	b

The order quantity should be an integral multiple of the "Minimum Quantity" shown above.

### ■ Dimensions of Reel

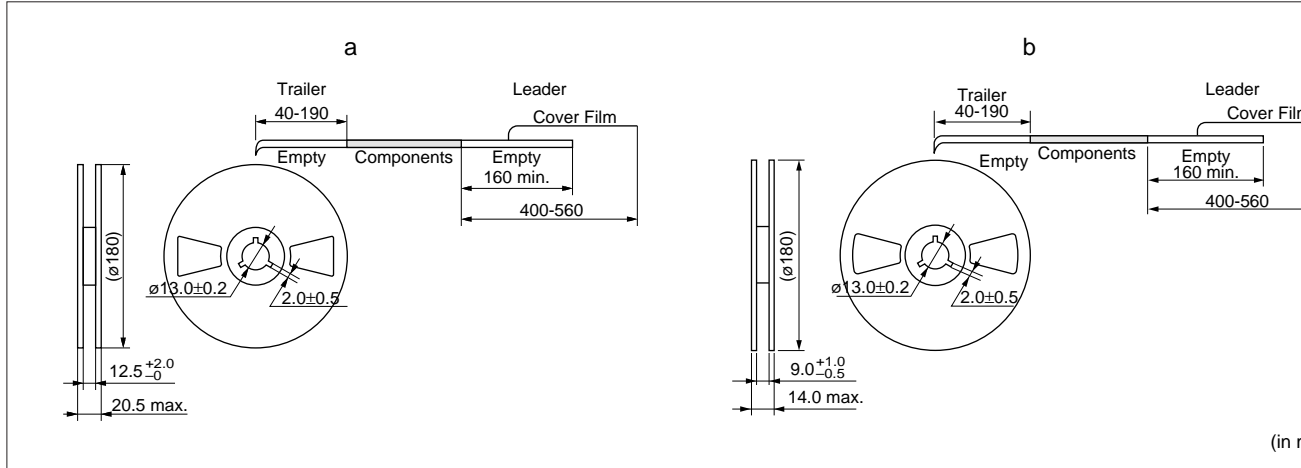

### ■ Dimensions of Taping

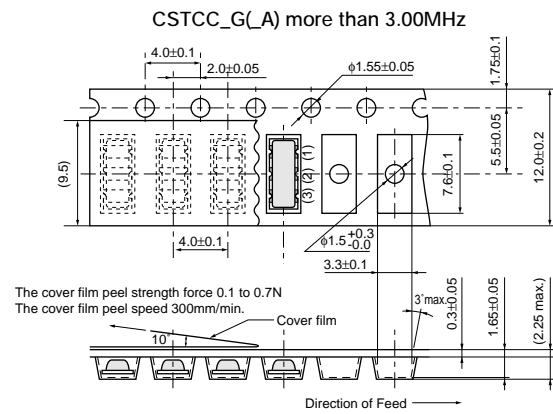
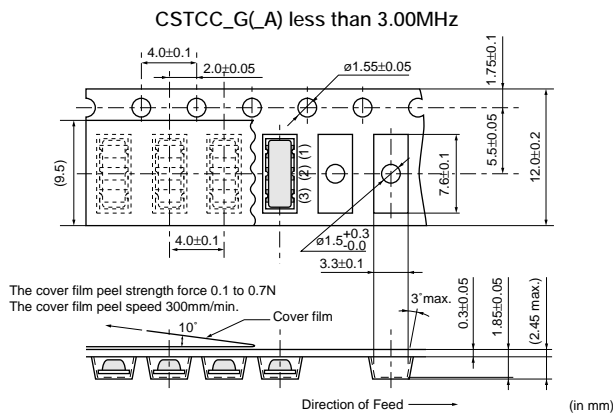

Continued on the following page

CSTCR\_G(LA)

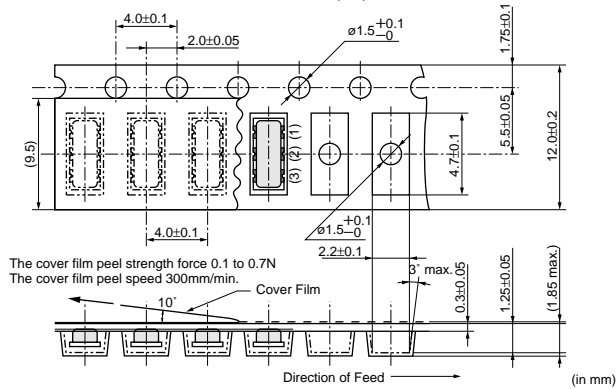

CSTCE\_G(LA)

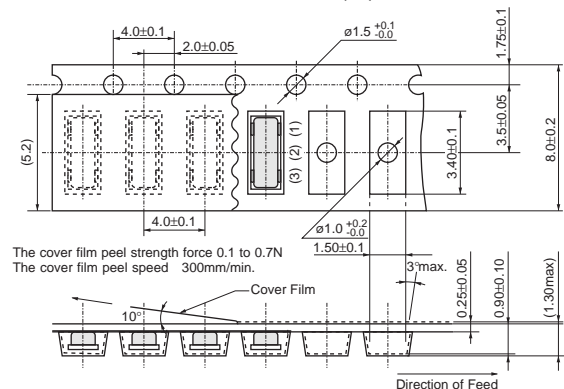

CSTCE\_V

Dimensions of Carrier Tape

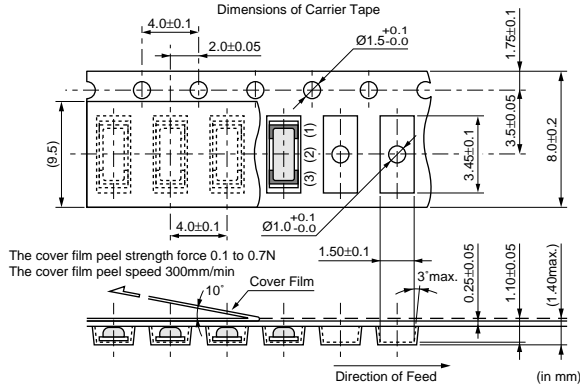

CSTCV\_X\_Q

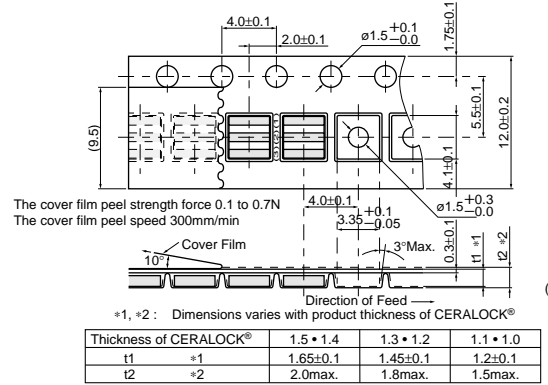

CSTCG\_V

Dimensions of Carrier Tape

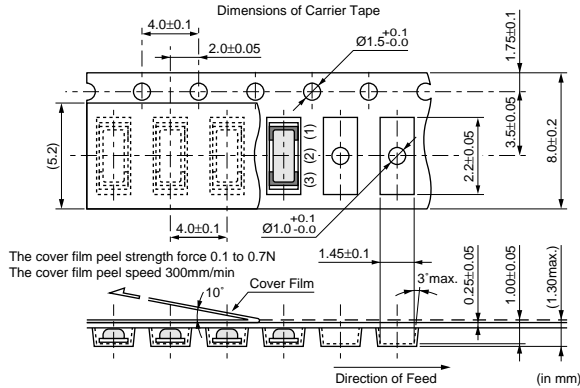

CSTCW\_X

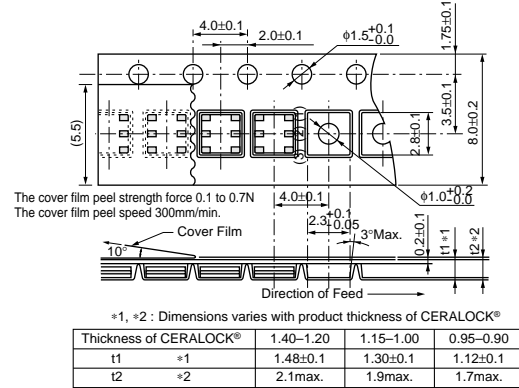

Part Number	Plastic Tape ø180mm	Plastic Tape ø330mm	Bulk	Dimensions
CSACV_X_Q	2,000	6,000	500	a
CSACW_X	3,000	9,000	500	b

The order quantity should be an integral multiple of the "Minimum Quantity" shown above.

### ■ Dimensions of Reel

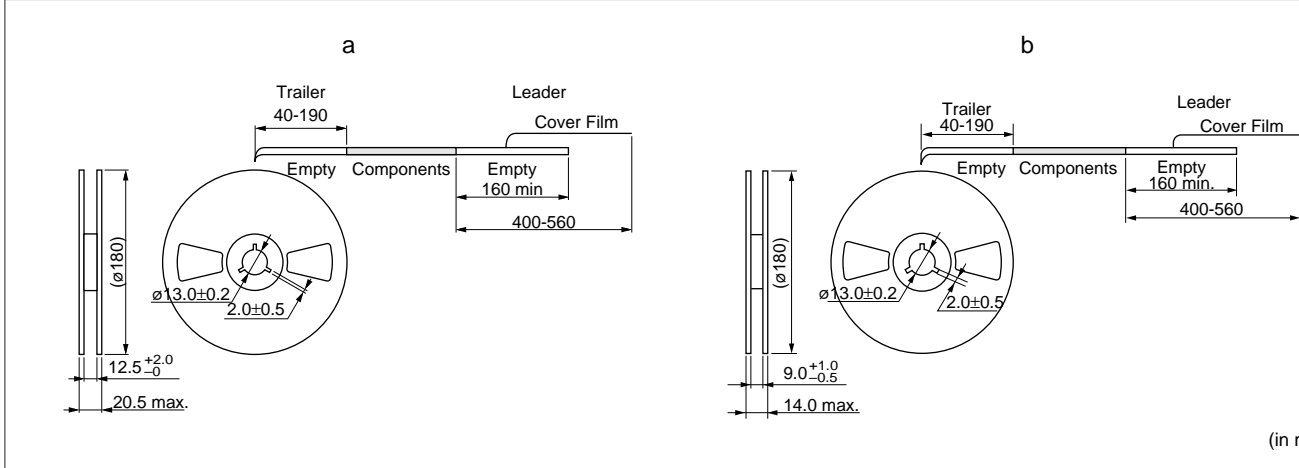

### ■ Dimensions of Taping

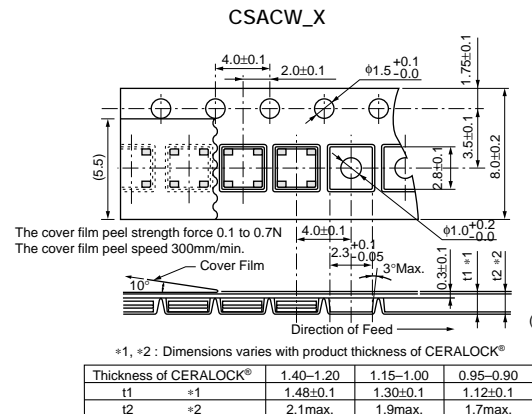
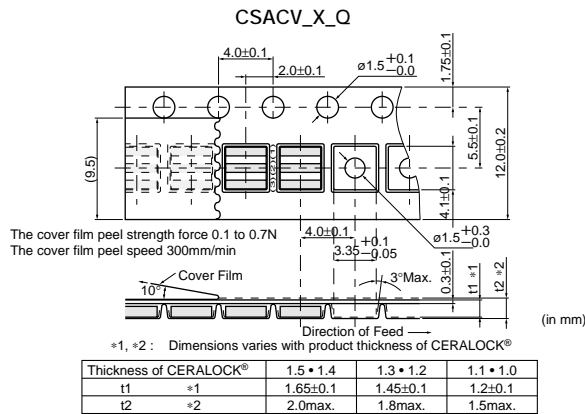

"CERALOCK" with built-in load capacitors.  
MURATA's ceramic resonator, "CERALOCK", has been widely applied as the most suitable component for clock oscillators in a broad range of microprocessors. The CSTLS series can be used in the design of oscillation circuits not requiring external load capacitors, enabling both high-density mounting and cost reduction.

■ Features

1. Oscillation circuits do not require external load capacitors.
2. The series is stable over a wide temperature range.
3. The resonators are compact, light weight and exhibit superior shock resistance performance.
4. They enable the design of oscillator circuits requiring no adjustment.
5. The series is inexpensive and available in stable supply.
6. There are some variation of built-in capacitance value to apply various of IC.

■ Applications

- DTMF generators.
- Clock oscillators for microcomputers.
- Remote control units.
- Automated office equipment.

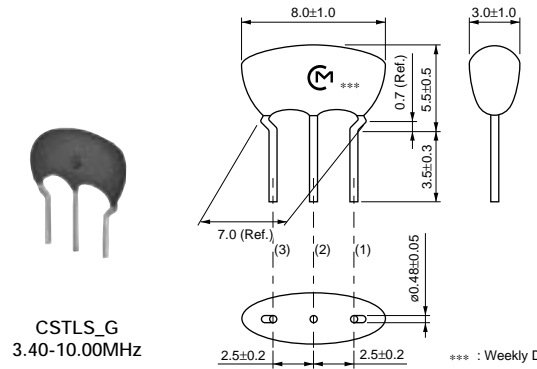

CSTLS\_G  
3.40-10.00MHz

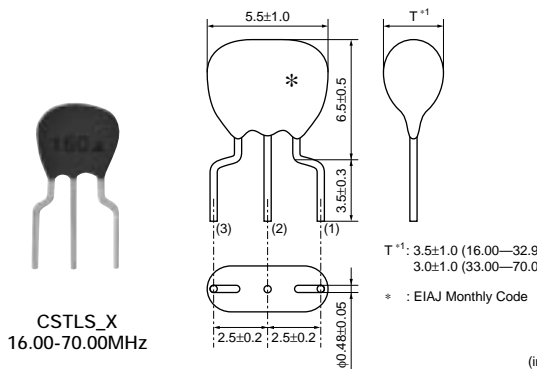

CSTLS\_X  
16.00-70.00MHz

Part Number	Oscillating Frequency (MHz)	Initial Tolerance (%)	Temp.Stability (%)	Temperature Range (°C)	Aging (10 years) (%)	Use
CSTLS_G	3.40 to 10.00	±0.5	±0.2	-20 to 80	±0.2	For consumer elect
CSTLS_X	16.00 to 70.00	±0.5	±0.2	-20 to 80	±0.2	For consumer elect

Irregular or stop oscillation may occur under unmatched circuit conditions. Please check the actual conditions prior to use.  
The order quantity should be an integral multiple of the "Minimum Quantity" shown in the packaging page.

■ Oscillation Frequency Measuring Circuit

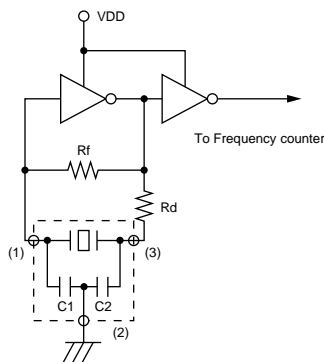



3

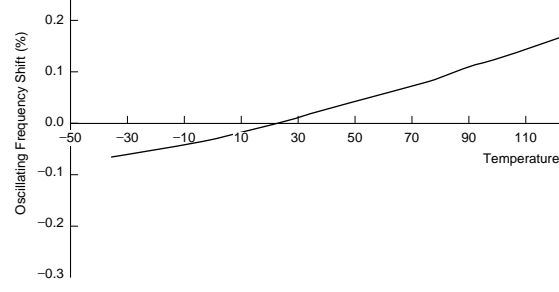
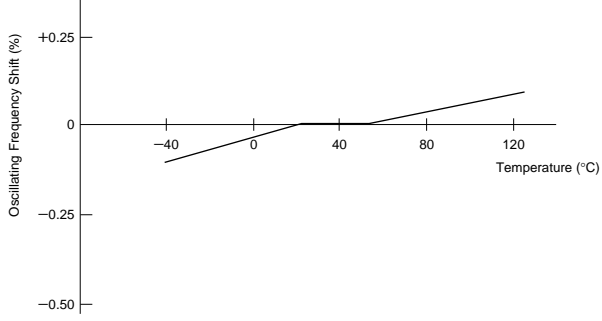

"CERALOCK" with two leaded terminals.

The CSALS series ceramic resonator owe their development to MURATA's innovative expert technologies and the application of mass production techniques typically utilized in the manufacture of piezoelectric ceramic components. Because of their high mechanical Q and consistent high quality, CSALS series are ideally suited to microprocessor and remote control unit applications.

In addition, MURATA offers a special "CERALOCK" version suitable for automatic insertion utilizing tape and reel and other packaging forms. For further information, please contact your local MURATA representative office or authorized distributor.

CSALS\_X  
16.00-70.00MHz

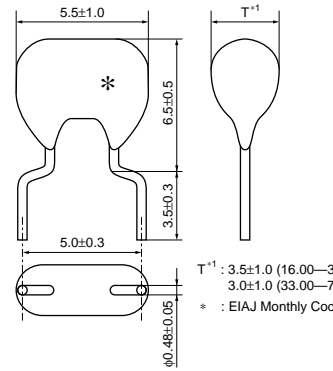

### ■ Features

1. The series is stable over a wide temperature range and with respect to long-term aging.
2. The series comprises fixed, tuned, solid-state devices.
3. The resonators are miniature and light weight.
4. They exhibit excellent shock resistance performance.
5. Oscillating circuits requiring no adjustment can be designed by utilizing these resonators in conjunction with transistors or appropriate ICs.

### ■ Applications

- Square-wave and sine-wave oscillator.
- Clock generator for microprocessors.
- Remote control systems.

Part Number	Oscillating Frequency (MHz)	Initial Tolerance (%)	Temp.Stability (%)	Temperature Range (°C)	Aging (10 years) (%)	Use
CSALS_X	16.00 to 70.00	±0.5	±0.2	-20 to 80	±0.2	For consumer elect

Irregular or stop oscillation may occur under unmatched circuit conditions. Please check the actual conditions prior to use.  
The order quantity should be an integral multiple of the "Minimum Quantity" shown in the packaging page.



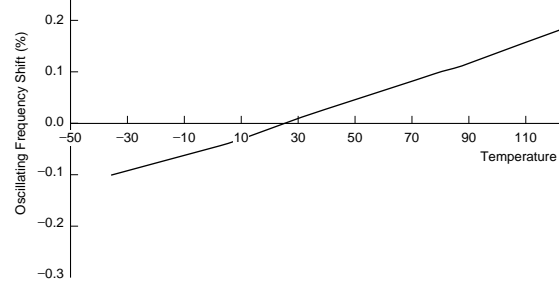
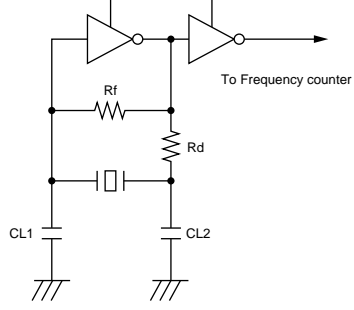

4

The component cannot be withstand washing.

■ **Notice (Storage and Operating Conditions)**

Please do not apply excess mechanical stress to the component and lead terminals at soldering.

Conformal coating or washing to the component is not acceptable. Because it is not hermetically sealed.

■ **Notice (Rating)**

The component may be damaged if excess mechanical stress is applied.

■ **Notice (Handling)**

"CERALOCK" may stop oscillating or oscillate irregularly under improper circuit conditions.



Part Number	Ammo Pack	Bulk
<b>CSTLS_G (3.40 to 10.0MHz)</b>	2,000	500
<b>CSTLS_X (16.00 to 70.00MHz)</b>	2,000	500

The order quantity should be an integral multiple of the "Minimum Quantity" shown above.

### ■ Tape Dimensions of CSTLS\_G

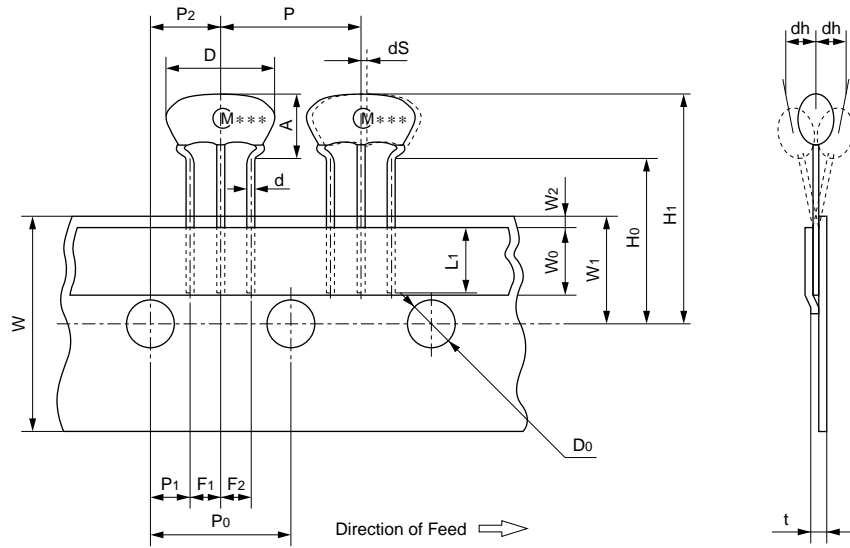

Item	Code	Dimensions	Tolerance	Remarks
Width of diameter	D	8.0	$\pm 1.0$	
Height of resonator	A	5.5	$\pm 0.5$	
Dimensions of terminal	d	$\phi 0.48$	$\pm 0.05$	
Lead length under the hold down tape	L1	5.0 min.	—	
Pitch of component	P	12.7	$\pm 0.5$	Tolerance for Pitches $10 \times P_0 = 127 \pm 1$
Pitch of sprocket hole	P0	12.7	$\pm 0.2$	
Length from sprocket hole center to lead	P1	3.85	$\pm 0.5$	
Length from sprocket hole center to component center	P2	6.35	$\pm 0.5$	
Lead spacing (I)	F1	2.5	$\pm 0.2$	
Lead spacing (II)	F2	2.5	$\pm 0.2$	
Slant to the forward or backward	dh	0	$\pm 1.0$	1mm max.
Width of carrier tape	W	18.0	$\pm 0.5$	
Width of hold down tape	W0	6.0 min.	—	Hold down tape does not exceed the carrier tape.
Position of sprocket hole	W1	9.0	$\pm 0.5$	
Gap of hold down tape and carrier tape	W2	0	$\begin{matrix} +0.5 \\ -0 \end{matrix}$	
Distance between the center of sprocket hole and lead stopper	H0	18.0	$\pm 0.5$	
Total height of resonator	H1	23.5	$\pm 1.0$	
Diameter of sprocket hole	D0	$\phi 4.0$	$\pm 0.2$	
Total tape thickness	t	0.6	$\pm 0.2$	
Body tilt	dS	0	$\pm 1.0$	

(in mm)

Continued on the following page

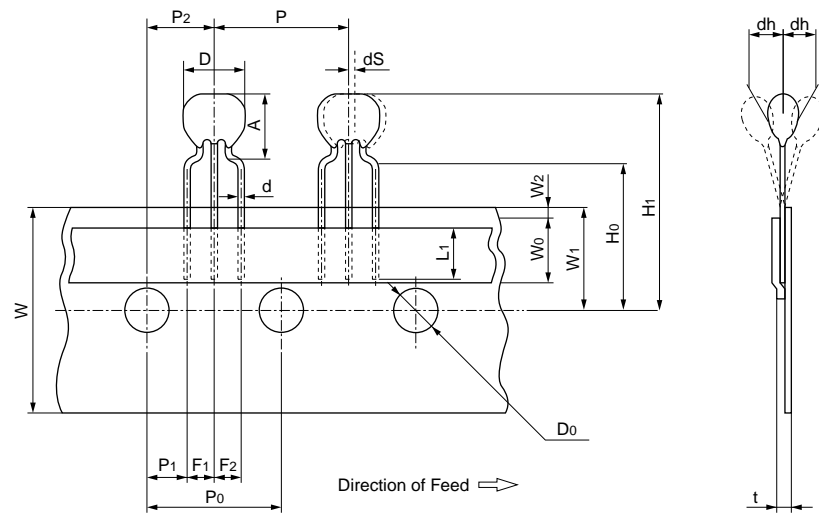

Item	Code	Dimensions	Tolerance	Remarks
Width of diameter	D	5.5	$\pm 1.0$	
Height of resonator	A	6.5	$\pm 0.5$	
Dimensions of terminal	d	$\phi 0.48$	$\pm 0.05$	
Lead length under the hold down tape	L1	5.0 min.	-	
Pitch of component	P	12.7	$\pm 0.5$	Tolerance for Pitches $10 \times P_0 = 127 \pm 1$
Pitch of sprocket hole	P0	12.7	$\pm 0.2$	
Length from sprocket hole center to lead	P1	3.85	$\pm 0.5$	
Length from sprocket hole center to component center	P2	6.35	$\pm 0.5$	
Lead spacing (I)	F1	2.5	$\pm 0.2$	
Lead spacing (II)	F2	2.5	$\pm 0.2$	
Slant to the forward or backward	dh	0	$\pm 1.0$	1mm max.
Width of carrier tape	W	18.0	$\pm 0.5$	
Width of hold down tape	W0	6.0 min.	-	Hold down tape doesn't exceed the carrier tape.
Position of sprocket hole	W1	9.0	$\pm 0.5$	
Gap of hold down tape and carrier tape	W2	0	$+0.5$ $-0.0$	
Distance between the center of sprocket hole and lead stopper	H0	18.0	$\pm 0.5$	
Total height of resonator	H1	24.5	$\pm 0.1$	
Diameter of sprocket hole	D0	$\phi 4.0$	$\pm 0.2$	
Total tape thickness	t	0.6	$\pm 0.2$	
Body tilt	dS	0	$\pm 1.0$	

(in mm)



Part Number	Ammo Pack	Bulk
CSALS_X (16.00 to 70.00MHz)	2,000	500

The order quantity should be an integral multiple of the "Minimum Quantity" shown above.

### ■ Tape Dimensions of CSALS

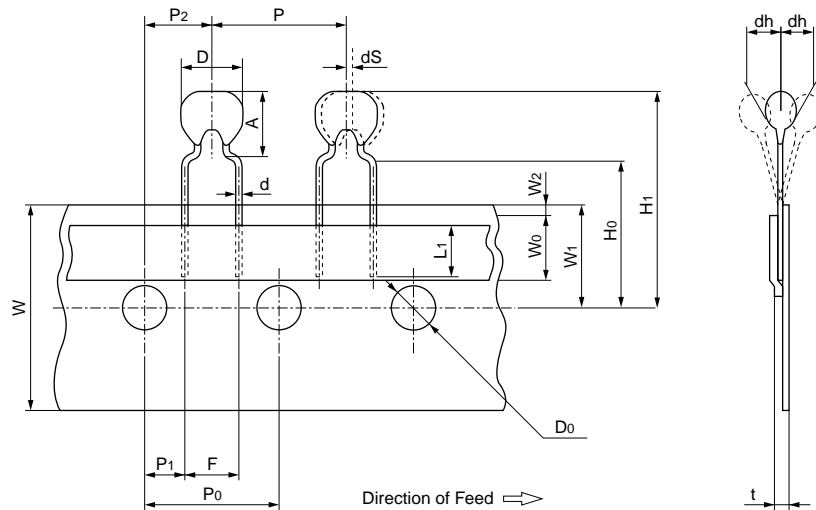

Item	Code	Dimensions	Tolerance	Remarks
Width of diameter	D	5.5	±1.0	
Height of resonator	A	6.5	±0.5	
Dimensions of terminal	d	ø0.48	±0.05	
Lead length under the hold down tape	L1	5.0 min.	—	
Pitch of component	P	12.7	±0.5	Tolerance for Pitches 10xP0=127±1
Pitch of sprocket hole	P0	12.7	±0.2	
Length from sprocket hole center to lead	P1	3.85	±0.5	
Length from sprocket hole center to component center	P2	6.35	±0.5	
Lead spacing	F	5.0	±0.3	
Slant to the forward or backward	dh	0	±1.0	1mm max.
Width of carrier tape	W	18.0	±0.5	
Width of hold down tape	W0	6.0 min.	—	Hold down tape doesn't exceed the carrier tape.
Position of sprocket hole	W1	9.0	±0.5	
Gap of hold down tape and carrier tape	W2	0	+0.5 -0	
Distance between the center of sprocket hole and lead stopper	H0	18.0	±0.5	
Total height of resonator	H1	24.5	±1.0	
Diameter of sprocket hole	D0	ø4.0	±0.2	
Total tape thickness	t	0.6	±0.2	
Body tilt	dS	0	±1.0	

(in mm)

Can be reflow soldered and mounted by automatic placers. MURATA's original package technologies have enabled the development of the kHz band "CERALOCK". The series is perfect in miniature remote control units and AV modules.

■ Features

1. The series withstands reflow soldering.
2. The series is mountable by automatic placers.
3. No adjustment is necessary for oscillation circuits.

■ Applications

- Clock oscillators for microprocessors.
- OA equipment.
- AV modules.



CSBFB\_J  
430-519kHz

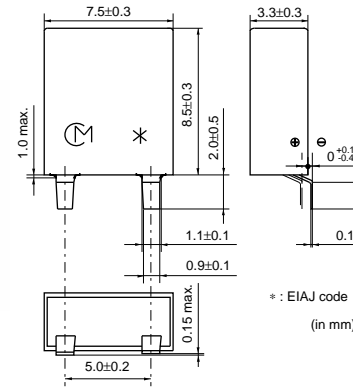

CSBFB\_J  
700-1250kHz

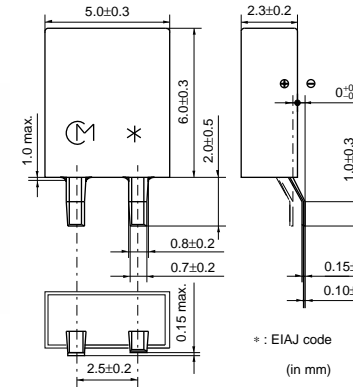

Part Number	Oscillating Frequency (kHz)	Initial Tolerance (%)	Temp.Stability (%)	Temperature Range (°C)	Aging (10 years) (%)	Use
CSBFB_J	430 to 519, 700 to 1250	±0.5	±0.3	-20 to 80	±0.3	-

Irregular or stop oscillation may occur under unmatched circuit conditions. Please check the actual conditions prior to use.

■ Oscillation Frequency Measuring Circuit

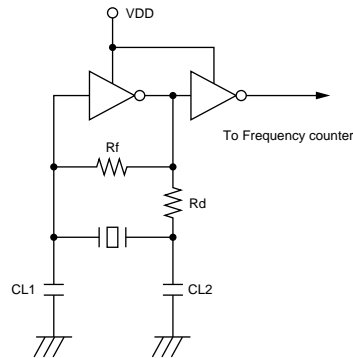

■ Oscillation Frequency Temperature Stability

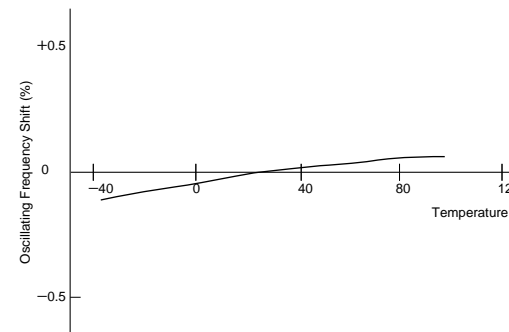

Continued on the following page





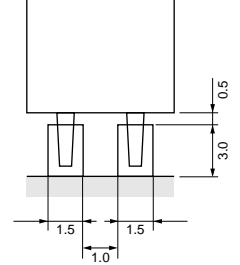
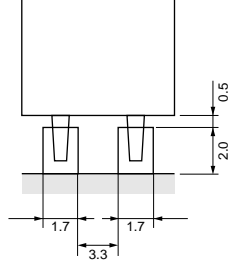

(in mm)

5

(1) Reflow

Right profile of heat stress is applied to resonator, then being place in natural condition for 1 hour, resonator shall be measured.

1. Pre-heating conditions shall be +140 to +160°C for 60 to 120 seconds. Ascending time up to +150°C shall be longer than 30 second.
2. Heating conditions shall be within 20 seconds at +225°C min., but peak temperature shall be lower than +235°C.

(2) Soldering Iron

Soldering iron of +270±5°C shall be placed 0.5mm above from electrode of resonator. Melting solder through soldering iron shall be applied to electrode for 3±1 seconds, then being place in natural condition for 24 hour, resonator shall be measured.

2. Wash

(1) Cleaning Solvent

HCFC, Isopropanol, Tap water, Demineralized water, Cleanthrough750H, Pine alpha 100S, Techno care FRW

(2) Temperature Difference : dT \*1

$dT \leq 60^\circ\text{C}$  (dT=Component-solvent)

\*1 ex. In case the component at +90°C immerses into cleaning solvent at +60°C, then dT=30°C.

(3) Condition

1. Ultrasonic Wash

1 minute max. in above solvent at +60°C max.  
(Frequency : 28kHz, Output : 20W/L)

2. Immersion Wash

5 minutes max. in above solvent at +60°C max.

3. Shower or Rinse Wash

5 minutes max. in above solvent at +60°C max.

(4) Drying

5 minutes max. by air blow at +80°C max.

(5) Others

1. Total washing time should be within 10 minutes.
2. Please insure the component is thoroughly evaluated in your application circuit.
3. The component may be damaged if it is washed with chlorine, petroleum, or alkali cleaning solvent.

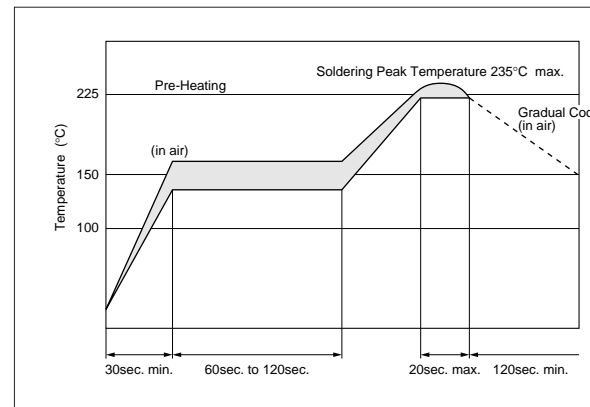

(1) Reflow

Right profile of heat stress is applied to resonator, then being place in natural condition for 1 hour, resonator shall be measured.

1. Pre-heating conditions shall be +140 to +160°C for 60 to 120 seconds. Ascending time up to +150°C shall be longer than 30 second.
2. Heating conditions shall be within 20 seconds at +215°C min., but peak temperature shall be lower than +225°C.

(2) Soldering Iron

Soldering iron of +270±5°C shall be placed 0.5mm above from electrode of resonator. Melting solder through soldering iron shall be applied to electrode for 3±1 seconds, then being place in natural condition for 24 hour, resonator shall be measured.

2. Wash

(1) Cleaning Solvent

HCFC, Isopropanol, Tap water, Demineralized water, Cleanthrough750H, Pine alpha 100S, Techno care FRW

5

(2) Temperature Difference : dT \*1

$dT \leq 60^\circ\text{C}$  (dT=Component-solvent)

\*1 ex. In case the component at +90°C immerses into cleaning solvent at +60°C, then dT=30°C.

(3) Condition

1. Ultrasonic Wash

1 minute max. in above solvent at +60°C max.  
(Frequency : 28kHz, Output : 20W/L)

2. Immersion Wash

5 minutes max. in above solvent at +60°C max.

3. Shower or Rinse Wash

5 minutes max. in above solvent at +60°C max.

(4) Drying

5 minutes max. by air blow at +80°C max.

(5) Others

1. Total washing time should be within 10 minutes.
2. Please insure the component is thoroughly evaluated in your application circuit.
3. The component may be damaged if it is washed with chlorine, petroleum, or alkali cleaning solvent.

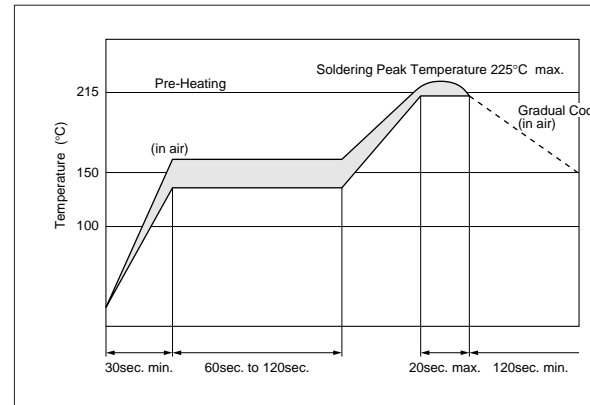

"CERALOCK" with two leaded terminals.

The CSBLA series ceramic resonator owe their development to MURATA's innovative expert technologies and the application of mass production techniques typically utilized in the manufacture of piezoelectric ceramic components. Because of their high mechanical Q and consistent high quality, the CSBLA series are ideally suited to microprocessor and remote control unit applications.

### ■ Features

1. The series is stable over a wide temperature range and with respect to long-term aging.
2. The series comprises fixed, tuned, solid-state devices.
3. The resonators are miniature and light weight.
4. They exhibit excellent shock resistance performance.
5. Oscillating circuits requiring no adjustment can be designed by utilizing these resonators in conjunction with transistors or appropriate ICs.

### ■ Applications

- Square-wave and sine-wave oscillator.
- Clock generator for microprocessors.
- Remote control systems.



CSBLA\_E  
375-429kHz

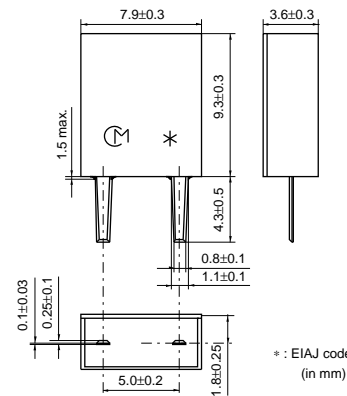

CSBLA\_E  
430-509kHz

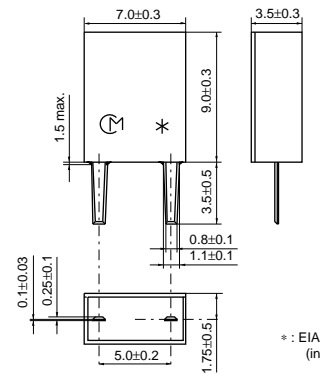

CSBLA\_E  
510-699kHz

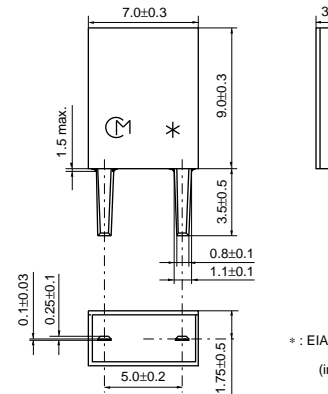

CSBLA\_J  
700-1250kHz

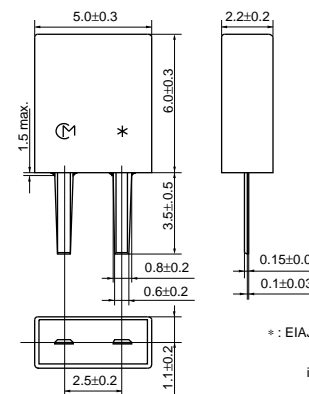

### ■ Oscillation Frequency Measuring Circuit

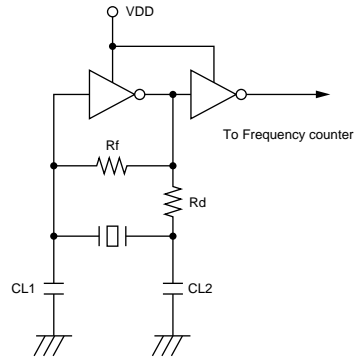

### ■ Oscillation Frequency Temperature Stability

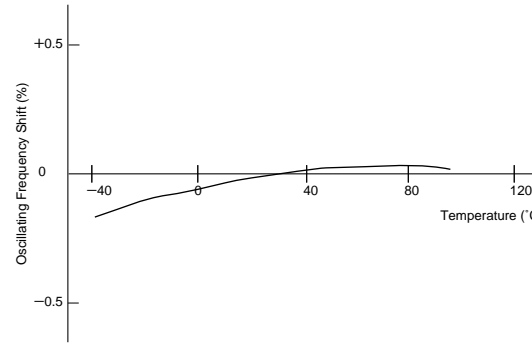

**■ Notice (Soldering and Mounting)**

## CSBLA\_J

## (1) Cleaning Solvent

HCFC, Isopropanol, Tap water, Demineralized water,  
Cleanthrough750H, Pine alpha 100S, Techno care  
FRW.

## (2) Temperature Difference:dT \*1

$dT \leq 30$  C. (dT=Component-solvent)

\*1 ex. In case the component at +90 C. immerses  
into cleaning solvent at +60 C., then  
 $dT=30$  C.

## (3) Condition

## 1. Ultrasonic Wash

1 minute max. in above solvent at +60 C. max.  
(Frequency:28kHz, Output:20W/L)

## 2. Immersion Wash

5 minutes max. in above solvent at +60 C. max.

## 3. Shower or Rinse Wash

5 minutes max. in above solvent at +60 C. max.

## (4) Drying

5 minutes max. by air blow at +80 C. max.

## (5) Others

1. Total washing time should be within 10 minutes.

2. Please insure the component is thoroughly  
evaluated in your application circuit.

3. The component may be damaged if it is washed  
with alkali cleaning solvent.



CSBFB\_J

Please do not apply excess mechanical stress to the component and lead terminals at soldering.

Conformal coating of the component is acceptable.

However, the resin material, curing temperature, and other process conditions should be evaluated to confirm stable electrical characteristics are maintained.

Ultrasonic cleaning of the component is acceptable.

■ Notice (Storage and Operating Condition)

CSBLA\_E

Please do not apply excess mechanical stress to the component and lead terminals at soldering.

Conformal coating or washing to the component is not acceptable. Because it is not hermetically sealed.

■ Notice (Storage and Operating Condition)

CSBLA\_J

Please do not apply excess mechanical stress to the component and lead terminals at soldering.

Conformal coating of the component is acceptable.

However, the resin material, curing temperature, and other process conditions should be evaluated to confirm stable electrical characteristics are maintained.

Ultrasonic cleaning of the component is acceptable.

However, the size of bath, size and thickness of PBC should be evaluated to confirm stable electrical characteristics are maintained.

■ Notice (Rating)

The component may be damaged if excess mechanical stress is applied.

■ Notice (Handling)

"CERALOCK" may stop oscillating or oscillate irregularly under improper circuit conditions.

However, the size of bath, size and thickness of PBC should be evaluated to confirm stable electrical characteristics are maintained.

In case of the bulk component, dry heating treatment (130 C. for 5 hours min.) is required before reflow soldering. Then, the component should be soldering within 48 hours after dry heating treatment.

Part Number	Plastic Tape ø330mm	Bulk
<b>CSBFB_J (430 to 519kHz)</b>	1,500	500
<b>CSBFB_J (700 to 1250kHz)</b>	3,000	1,000

The order quantity should be an integral multiple of the "Minimum Quantity" shown above.

### ■ Dimensions of Reel

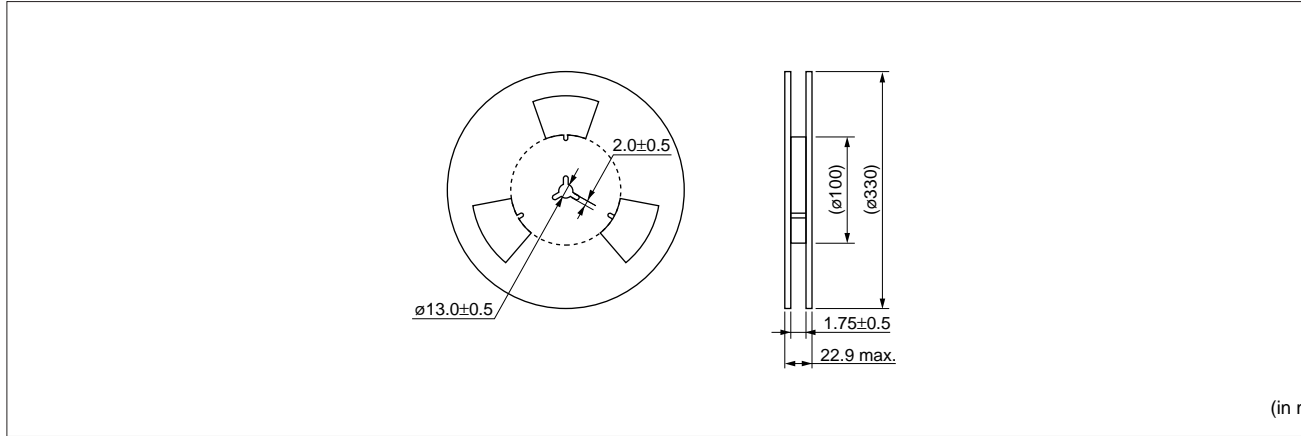

### ■ Dimensions of Taping

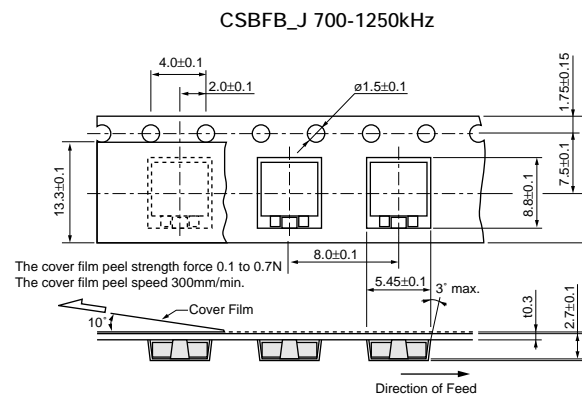
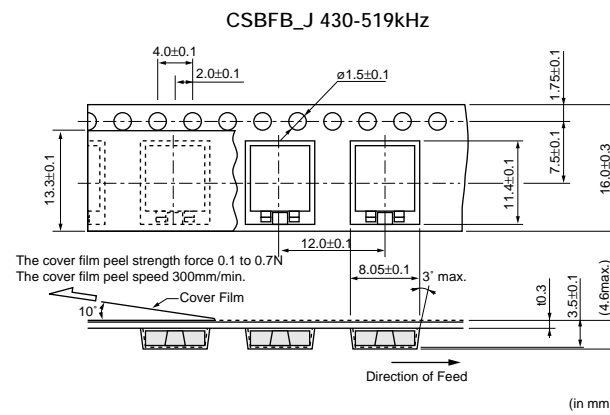

### ■ CSBLA Series Minimum Quantity

Part Number	Magazine	Bulk
<b>CSBLA_E</b>	50	500
<b>CSBLA_J</b>	100	1,000

The order quantity should be an integral multiple of the "Minimum Quantity" shown above.





### 8-bit Microcomputer

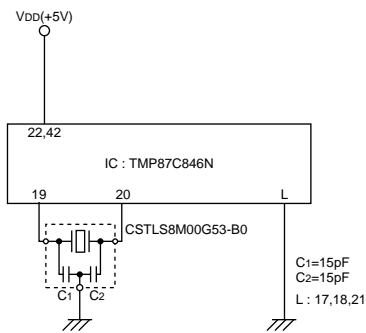

### 8-bit Microcomputer

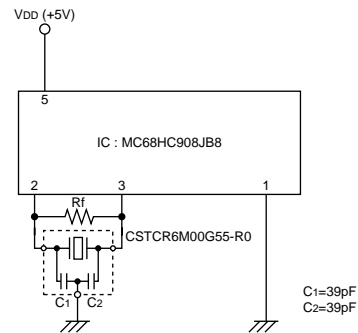

### ■ uPD78018F (NEC)

#### 8-bit Microcomputer

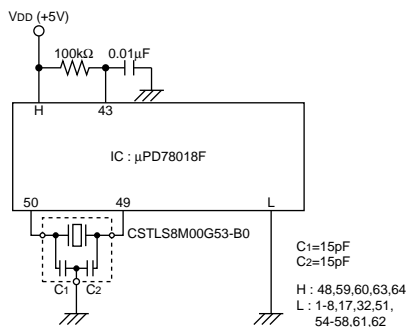

### ■ HD64F3337 (HITACHI)

#### 8-bit Microcomputer

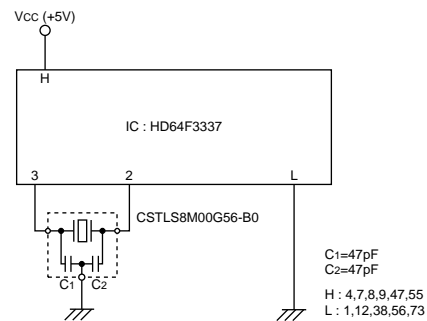

### ■ ML66517 (OKI)

#### 8-bit Microcomputer

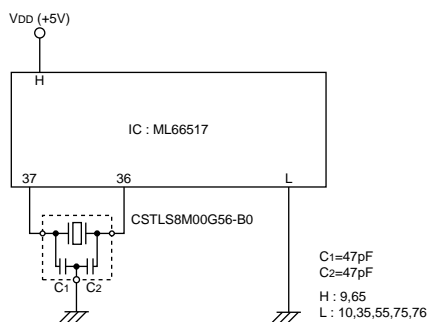

### ■ M38039MF (MITSUBISHI)

#### 8-bit Microcomputer

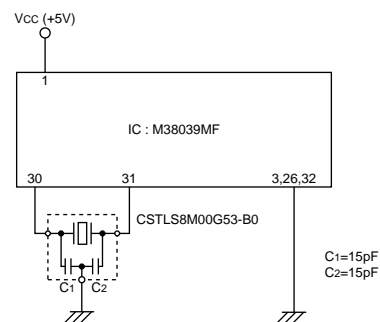

Continued on the following page

Remote Control Unit

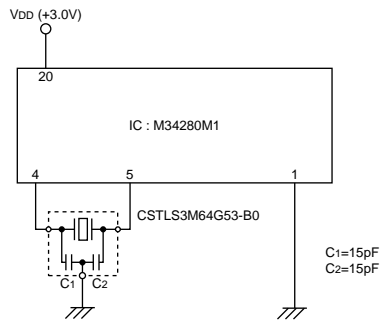

Speech Synthesizer

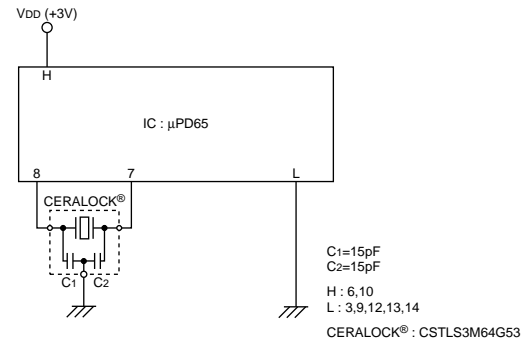

■ uPD754304 (NEC)

4-bit Microcomputer

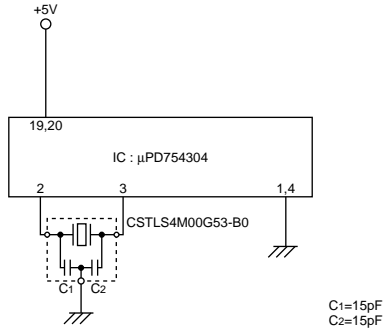

■ LC651154F (SANYO)

4-bit Microcomputer

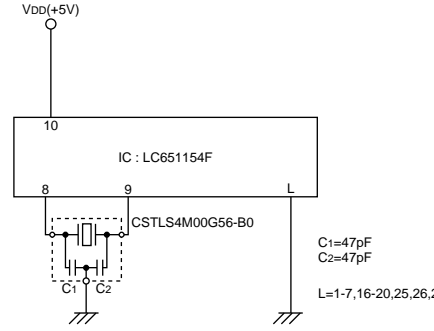

■ LC7367JM (SANYO)

Tone/Pulse Dialer

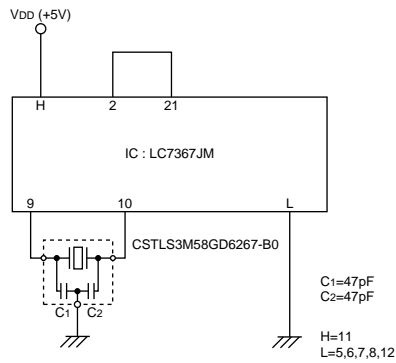

■ ML7005MB (OKI)

Tone/Pulse Dialer

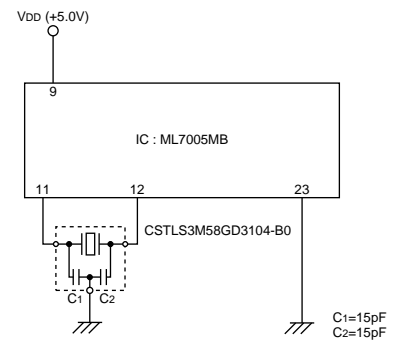

Continued on the following page



### 32-bit Microcomputer

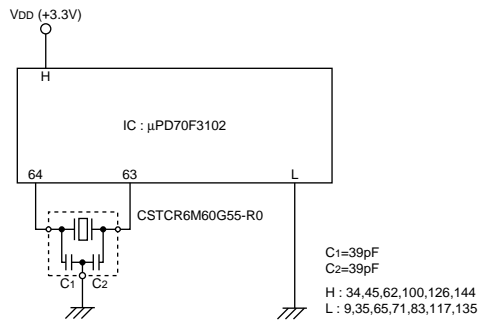

### Digital Signal Processing IC for CD

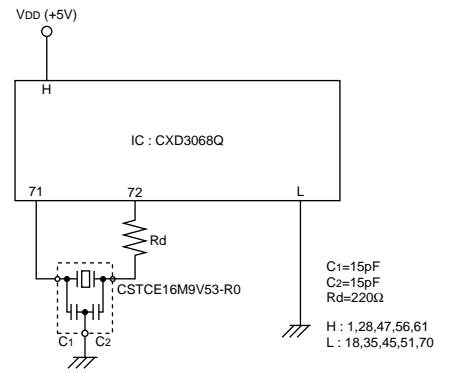

### LC895299 (SANYO)

Error Correction of CD-ROM LSI

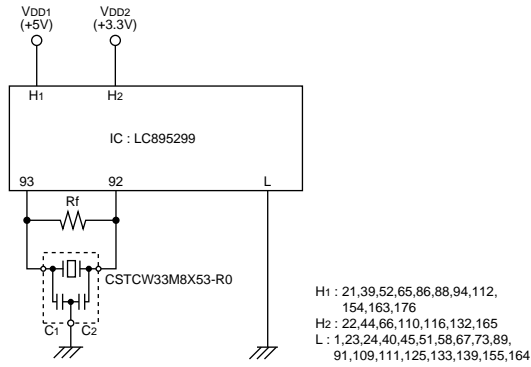

### TMP47C660AN (TOSHIBA)

4-bit Microcomputer

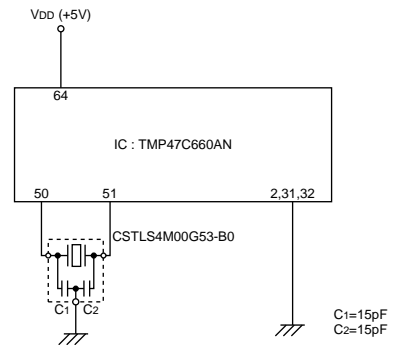

### TA8690AN (TOSHIBA)

TV Horizontal/Compatible with Synthesizer Circuit

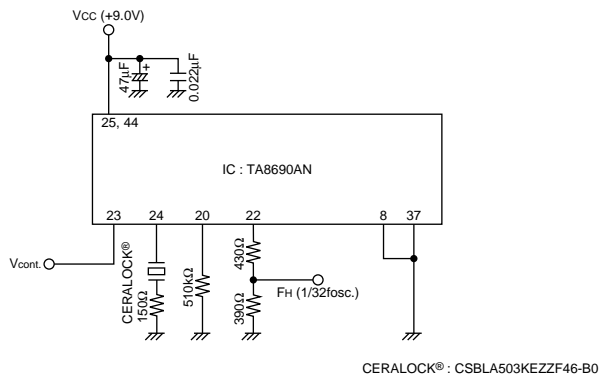

### LA3410 (SANYO)

FM Stereo MPX

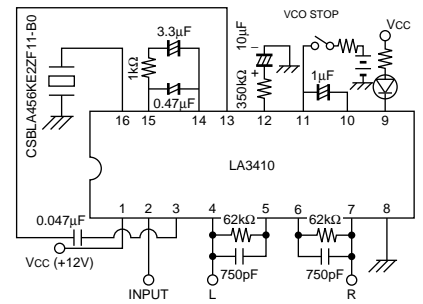

Continued on the following page

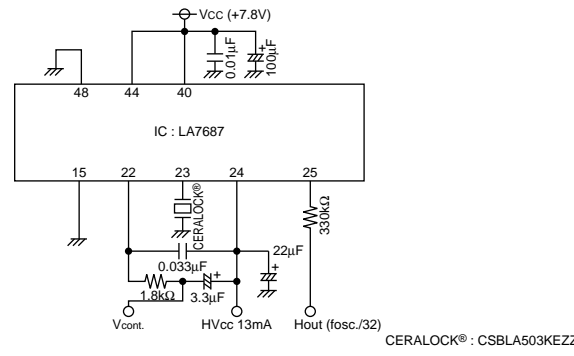
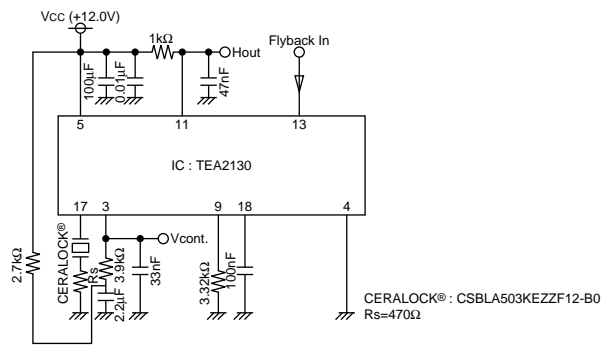

■ Oscillation Circuit Incorporating Transistor

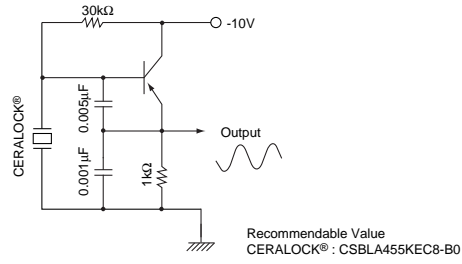

**⚠ Note:**

1. Export Control

⟨For customers outside Japan⟩

Murata products should not be used or sold for use in the development, production, stockpiling or utilization of any conventional weapons or mass-destruction weapons (nuclear weapons, chemical or biological weapons, or missiles), or any other weapons.

⟨For customers in Japan⟩

For products which are controlled items subject to the "Foreign Exchange and Foreign Trade Law" of Japan, the export license specified by the law is required for export.

2. Please contact our sales representatives or product engineers before using our products listed in this catalog for the applications listed below which require especially high reliability for the prevention of defects which might directly cause damage to the third party's life, body or property, or when intending to use our products for other applications than specified in this catalog.

① Aircraft equipment

② Aerospace equipment

③ Undersea equipment

④ Power plant equipment

⑤ Medical equipment

⑥ Transportation equipment (vehicles, trains, ships, etc.)

⑦ Traffic signal equipment

⑧ Disaster prevention / crime prevention equipment

⑨ Data-processing equipment

⑩ Application of similar complexity and/or reliability requirements to the applications listed in the above

3. Product specifications in this catalog are as of May 2002. They are subject to change or our products in it may be discontinued without advance notice. Please check with our sales representatives or product engineers before ordering. If there are any questions, please contact our sales representatives or product engineers.

4. Please read rating and ⚠CAUTION (for storage and operating, rating, soldering and mounting, handling) in this catalog to prevent smoking and/or burning.

5. This catalog has only typical specifications because there is no space for detailed specifications. Therefore, please approve our product specification or the approval sheet for product specification before ordering.

6. Please read CAUTION and Notice in this catalog for safety. This catalog has only typical specifications. Therefore you are requested to approve our product specification or to transact the approval sheet for product specification, before ordering.

7. Please note that unless otherwise specified, we shall assume no responsibility whatsoever for any conflict or dispute that may occur in connection with the use of our and/or third party's intellectual property rights and other related rights in consideration of your using our products and/or information described contained in our catalogs. In this connection, no representation shall be made to the effect that any third parties are authorized to use the rights mentioned above under licenses without our consent.

8. No ozone depleting substances (ODS) under the Montreal Protocol are used in our manufacturing process.

 **Murata Manufacturing Co., Ltd.**

<http://www.murata.com>

**Head Office**

2-26-10, Tenjin Nagaokakyo-shi, Kyoto 617-8555, Japan Phone: 81-75-951-9111

**International Division**

3-29-12, Shibuya, Shibuya-ku, Tokyo 150-0002, Japan  
Phone: 81-3-5469-6123 Fax: 81-3-5469-6155 E-mail: [intl@murata.co.jp](mailto:intl@murata.co.jp)