

LOC		DIST		REVISIONS						
P	LTR REV	DESCRIPTION MODIFICATIONS			DATE	DWN DESS.	APVD APP.			
FH		00		F	MISE A JOURS / AJOUT NOTA			07DEC2009	BG	GP
		G	ECR-11-018538			07SEP2011	LP	NA		

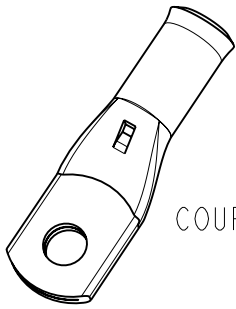

COUPE A-A

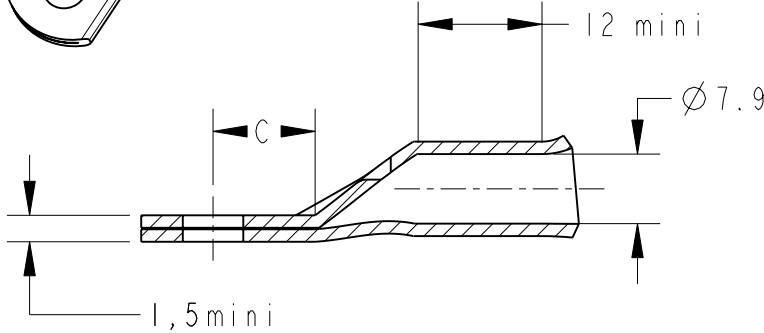

Inspection hole



Ces produits répondent à la norme NFC 20-130.
 These products are NFC 20-130 compliant.

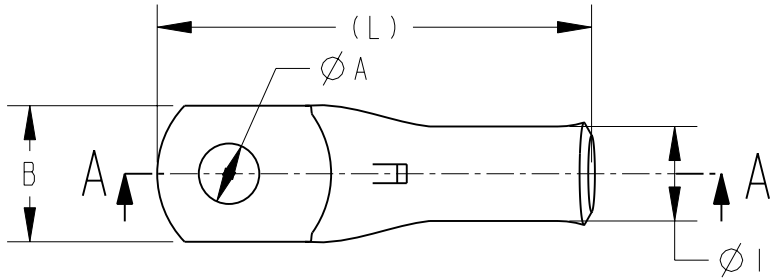

(L)	C	B	Ø A	DESCRIPTION	PART NUMBER
39	7	15	6,4	XCT 35-6	710027-1
46	11	17	8,3	XCT 35-8	710027-2
46	11	17	10,3	XCT 35-10	710036-3
46	11	17	12,8	XCT 35-12	710036-4

- 1 - MATERIAL = TINNED COPPER
- 2 - Marking in depth: logo-section-hole-Made in France +
- 3 - CABLE SECTION = 2AWG or 35mm²
- 4 - GROOVE E35Cu OR DIE (Punch 17P50+ Die 17M35)

TOLERANCES UNLESS OTHERWISE SPECIFIED: -
 TOLERANCES NON SPECIFIEES: -

DIMENSIONS: mm	DWN/DESSINE D. LEGUY	15DEC00	MATERIAL MATIERE	CUIVRE		FINISH FINITION	ETAME			
	CHK/VERIFIE E. DEREY	-	 TE Connectivity							
TOLERANCES UNLESS OTHERWISE SPECIFIED: TOLERANCES NON SPECIFIEES (SUIV NB DE DECIMALES): 0 PLC/DEC: ±0 1 PLC/DEC: ±0 2 PLC/DEC: ±0 3 PLC/DEC: ±0 4 PLC/DEC: ±0 ANGLES ±-	APVD/APPROUVE N. ALMEIDA	-							NAME TITRE	XCT 35-..
	PRODUCT SPEC SPEC. PRODUIT	-	SIZE FORMAT	CAGE CODE	DRAWING NO No PLAN	RESTRICTED TO RESERVE A				
	APPLICATION SPEC SPEC. APPLICATION	-	A4	00779	C=710027					
	WEIGHT MASSE APPROX.		CUSTOMER DRAWING /PLAN CLIENT			UNIQUEMENT POUR REFERENCE	SCALE ECHELLE - / -	SHEET FEUILLE	OF DE	REV G