

# APPROVAL SHEET

**WK12L, WK20L, WK25L**

**±1%, ±5%**

Thick Film Power Chip Resistor

Wide Termination

RoHS compliant and Halogen free

Size 0612, 1020, 1225

Automotive AEC Q200 Compliant

ASTM B-809-95 Compliant

\*Contents in this sheet are subject to change without prior notice.

## FEATURE

1. High power rating and compact size
2. High reliability and stability
3. Reduced size of final equipment
4. RoHS compliant and Halogen free products
5. AEC Q200 Compliant
6. ASTM B-809-95 60°C 1000hrs compliant

## APPLICATION

- Power supply
- PDA
- Digital meter
- Computer
- Automotives
- Battery charger
- DC-DC power converter

## DESCRIPTION

The resistors are constructed in a high grade ceramic body (aluminum oxide). Internal metal electrodes are added at each end and connected by a resistive paste that is applied to the top surface of the substrate. The composition of the paste is adjusted to give the approximate resistance required and the value is trimmed to nominated value within tolerance which controlled by laser trimming of this resistive layer.

The resistive layer is covered with a protective coat. Finally, the two external end terminations are added at longer sides. For ease of soldering the outer layer of these end terminations is Tin (lead free) alloy.

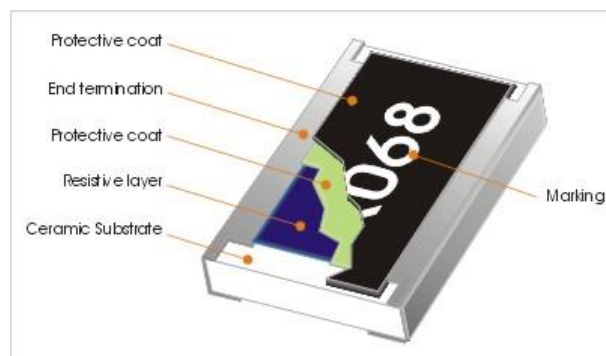

Fig 2. Construction of Chip-R

**QUICK REFERENCE DATA**

Item	General Specification		
	WK12L	WK20L	WK25L
Series No.	WK12L	WK20L	WK25L
Size code	0612(1632)	1020 ( 2550 ),	1225(3264)
Resistance Tolerance	±5% (E24); ±1% (E24+E96)		
Resistance Range	1Ω ~ 1MΩ,		
TCR (ppm/°C) :	± 200 ppm/°C	± 200 ppm/°C	± 200 ppm/°C
Max. dissipation at T <sub>amb</sub> =70°C	3/4W	1 W	2W
Max. Operation Voltage (DC or RMS)	200V	200V	200V
Max. Overload Voltage (DC or RMS)	400V	400V	400V
Climatic category (IEC 60068)	55/155/56		

Note :

1. This is the maximum voltage that may be continuously supplied to the resistor element, see "IEC publication 60115-8"
2. Max. Operation Voltage : So called RCWV (Rated Continuous Working Voltage) is determined by

$$RCWV = \sqrt{\text{Rated Power} \times \text{Resistance Value}} \text{ or Max. RCWV listed above, whichever is lower.}$$

**MECHANICAL DATA (unit : mm)**

TYPE	WK12L	WK20L	WK25L
W	3.20±0.20	5.00±0.20	6.30±0.20
L	1.60±0.20	2.50±0.15	3.20±0.20
H	0.55±0.10	0.55±0.10	0.55±0.10
c	0.50±0.25	0.60±0.20	0.60±0.20
d	0.50±0.25	0.60±0.20	0.60±0.20

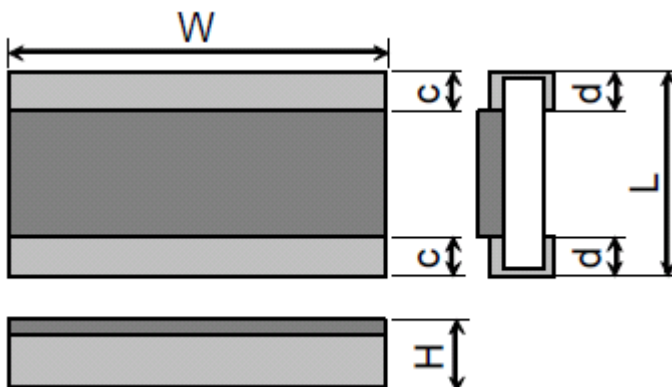

## MARKING

Each resistor is marked with a four-digit code on the protective coating to designate the nominal resistance value.

Example:

1R00 = 1Ω  
 3901 = 3900Ω  
 1101 = 1100Ω



## FUNCTIONAL DESCRIPTION

### Product characterization

Standard values of nominal resistance are taken from the E96 & E24 series for resistors with a tolerance of  $\pm 5\%$  &  $\pm 1\%$ . The values of the E24/E96 series are in accordance with "IEC publication 60063".

### Derating curve

The power that the resistor can dissipate depends on the operating temperature; see Fig.3

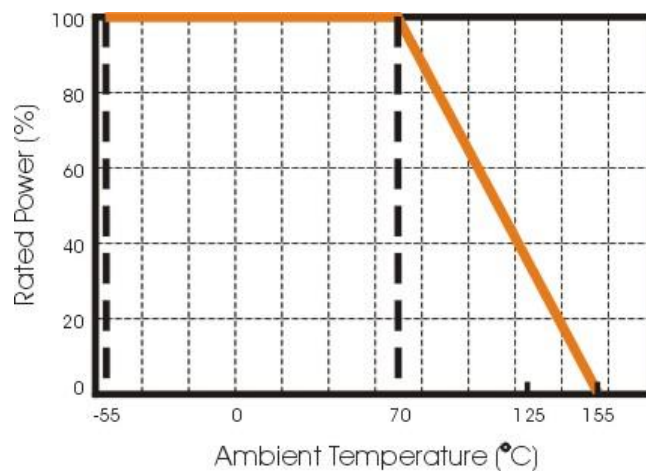

Figure 3. Maximum dissipation in percentage of rated power as a function of the ambient temperature.

## MOUNTING

Due to their rectangular shapes and small tolerances, Surface Mountable Resistors are suitable for handling by automatic placement systems.

Chip placement can be on ceramic substrates and printed-circuit boards (PCBs).

Electrical connection to the circuit is by individual soldering condition.

The end terminations guarantee a reliable contact.

### SOLDERING CONDITION

The robust construction of chip resistors allows them to be completely immersed in a solder bath of 260°C for 10 seconds. Therefore, it is possible to mount Surface Mount Resistors on one side of a PCB and other discrete components on the reverse (mixed PCBs).

Surface Mount Resistors are tested for solderability at 235°C during 2 seconds. The test condition for no leaching is 260°C for 30 seconds. Typical examples of soldering processes that provide reliable joints without any damage are given in Fig 4.

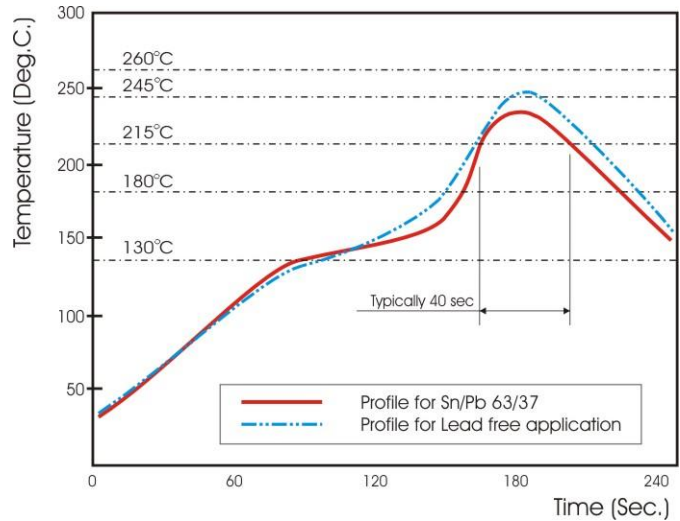

Fig 4. Infrared soldering profile for Chip Resistors

### CATALOGUE NUMBERS

The resistors have a catalogue number starting with .

WK12	L	472_	J	T	L	V
<b>Size code</b>	<b>Type code</b>	<b>Resistance code</b>	<b>Tolerance</b>	<b>Packaging code</b>	<b>Termination code</b>	<b>Special code</b>
WK25 : 1225 WK20 : 1020 WK12: 0612	L : wide termination	<b>5% E24</b> : 2 significant digits followed by no. of zeros and a blank  4.7Ω =4R7_ 10Ω =100_  <b>1% E24+E96</b> : 3 significant digits followed by no. of zeros  102Ω =1020 37.4KΩ =3742	J : ±5% F : ±1% P : Jumper	T : 7" Reel taping	L = Sn base (lead free)	V = AEC Q200 Compliant + ASTM B-809-95 Compliant

**TEST AND REQUIREMENTS ( AEC Q200 )**

No.	Test items	Condition of test	Performance requirements
1	High temperature exposure AEC Q200 - No.3	MIL-STD-202 Method 108 Ambient temperature: 155±2°C, Condition: Without load, Duration: 1000 <sup>+48</sup> <sub>0</sub> h Interval measurements: 250 h and 500 h	Resistor: ΔR/R: Within ± (3%+0.1Ω) Chip jumper: 50mΩ max. No visible damage
2	Temperature cycling AEC Q200 - No.4	JESD22 Method JA-104 Temperature: -55±3°C / 125±2°C, Dwell time: 30min maximum at each temp. Transition time: 1 min. max. Number of cycles: 1000 cycles. Interval measurements: 250 cy and 500 cy	Resistor: ΔR/R: Within ± (1%+0.05Ω) Chip jumper: 50mΩ max. No visible damage
3	Bias humidity AEC Q200 – No.7	MIL-STD-202 Method 103 Condition: 85°C & 85% R.H. Test power: 10% of rated power shall be applied for continuously. Duration: 1,000 <sup>+48</sup> <sub>0</sub> h Interval measurements: 250 h and 500 h	Resistor: ΔR/R: Within ± (3%+0.1Ω) Chip jumper: 50mΩ max. No visible damage
4	Operational life AEC Q200 – No.8	MIL-STD-202 Method 108 Ambient temperature: 125±2°C The applied voltage shall be the voltage to be calculated at 35% of rated dissipation or the limiting element voltage whichever is the smaller. Condition: The voltage shall be applied for continuously. Duration: 1000 <sup>+48</sup> <sub>0</sub> h Interval measurements: 250 h and 500 h	Resistor: ΔR/R: Within ± (3%+0.1Ω) Chip jumper: 50mΩ max. No visible damage
5	Dimensions AEC Q200 – No.10	JESD22 Method JB-100	As in Table-3
6	Resistance to Solvents AEC Q200 – No.12	MIL-STD-202 Method 215 Solvent: 2-propanol at 25°C Immersion time: 3 min Brush: 10 times brushing Immersion and brush cycle: 3cycle	Resistor: ΔR/R: Within ± (1%+0.05Ω) Chip jumper: 50mΩ max. No visible damage
7	Mechanical Shock AEC Q200 – No.13	MIL-STD-202 Method 213 Waveform: half sine, Peak value 100G, Normal duration 6ms Condition: XX'YY'ZZ', 10times each	Resistor: ΔR/R: Within ± (1%+0.05Ω) Chip jumper: 50mΩ max. No visible damage
8	Vibration AEC Q200 – No.14	MIL-STD-202 Method 204 Peak acceleration and Sweep time: 5 g's for 20 min , Frequency 10Hz to 2000Hz, Condition: 12 cycles each of 3 orientations	Resistor: ΔR/R: Within ± (1%+0.05Ω) Chip jumper: 50mΩ max. No visible damage
9	Resistance to soldering heat AEC Q200 - No.15	MIL-STD-202 Method 210 Solder bath temp: 260±5°C Immersed time: 10±1s	Resistor: ΔR/R: Within ± (1%+0.05Ω) Chip jumper: 50mΩ max. No visible damage

Approval sheet

No	Test items	Condition of test	Performance requirements
10	ESD test AEC Q200 – No.17	AEC-Q200-002 Human body model, 2 Kohm, 150 pF, Test voltage: 2000V	Resistor: $\Delta R/R$ : Within $\pm (5\%+0.1\Omega)$ Chip jumper: 50m $\Omega$ max. No visible damage
11	Solderability AEC Q200 – No.18	J-STD-002 a) Bake the sample for 155 °C dwell time 4h / solder dipping 235°C/ 5s. Solder: Sn96.5-Ag3-Cu0.5 b) Category 3, Solder dipping 215°C/ 5s. Solder: Sn63Pb37 c) Category 3, Solder dipping 260°C/ 7s.	The surface of terminal immersed shall be min. of 95% covered with a new coating of solder.
12	Electrical Characterization AEC Q200 - No.19	1. D.C. Resistance 2. Temperature Coefficient of Resistance -55 °C / +20 °C +20 °C / +125°C	1. The resistance value shall correspond with the rated resistance taking into account the specified tolerance. 2. As in Table-1
13	Bending strength AEC Q200 – No.21	AEC-Q200-005 Bending value 2mm Holding time: 60sec.	Resistor: $\Delta R/R$ : Within $\pm (1\%+0.05\Omega)$ Chip jumper: 50m $\Omega$ max. No visible damage
14	Adhesion AEC Q200 – No.22	AEC-Q200-006 Pressurizing force: 17.7N Test time: 60 $\pm$ 1s.	Resistor: $\Delta R/R$ : Within $\pm (1\%+0.05\Omega)$ Chip jumper: 50m $\Omega$ max. No visible damage
15	Humid Sulfur vapor test (FOS)	ASTM B809 Reagent: Sulfur (Saturated vapor) Test temp.: 60°C Relative humidity: 95%RH Test period: 1000h	Resistor: $\Delta R/R$ : Within $\pm (1.0\%+0.05\Omega)$ Chip jumper: 50m $\Omega$ max. No visible damage

**PACKAGING**

Tape specifications (unit :mm)

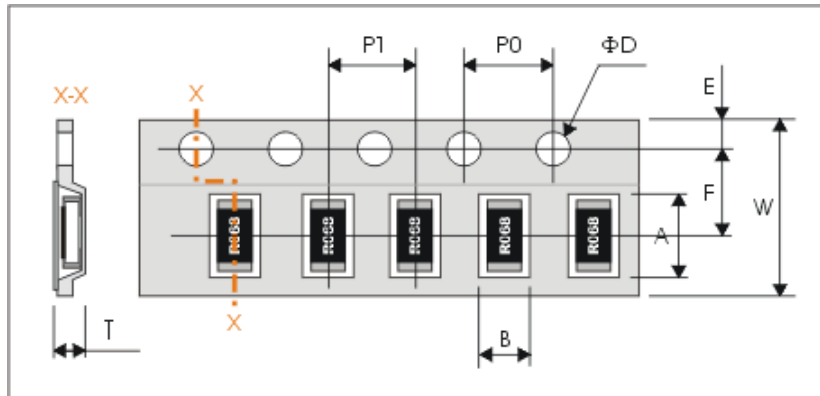

Type	A	B	W	F	E
WK12L	3.60±0.20	2.00±0.15	8.00±0.30	3.50±0.10	1.75±0.10
WK20L	5.50±0.20	3.10±0.20	12.00±0.30	5.50±0.10	
WK25L	6.90±0.20	3.60±0.20	12.00±0.30	5.50±0.10	

Type	P1	P0	ΦD	T
WK12L	4.00±0.10	4.00±0.10	Φ1.50 <sup>+0.1</sup> <sub>-0.0</sub>	Max 1.0
WK20L				1.10±0.15
WK25L				1.10±0.15

**Reel dimensions**

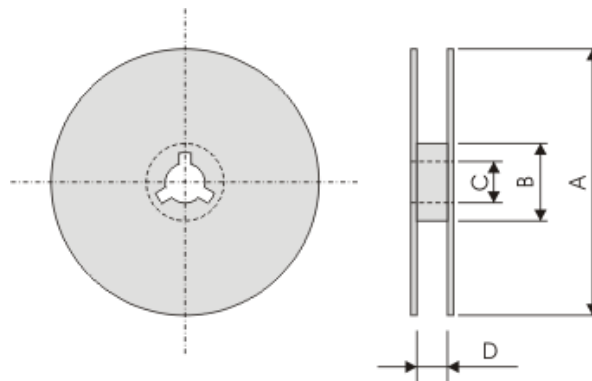

(unit : mm)

Symbol	A	B	C	D
7" Reel	Φ178.0±2.0	Φ60.0±1.0	13.0±0.2	12.4.0±1.00
10" Reel	Φ254.0±2.0	Φ100.0±1.0	13.0±0.2	14.0±0.20
13" Reel	Φ330.0±2.0	Φ100.0±1.0	13.0±0.2	14.0±0.20

**Taping quantity**

WK20L, WK25L by plastic tape taping 4,000 pcs per 7" reel!

WK12L by paper tape taping 5,000 pcs per 7" reel!