

SPECIFICATION FOR APPROVAL

承 認 書

Description : Piezo Audio Transducer
Kingstate Part No. : KMTG1203
Customer's Model No. : _____
Specification No. : POD-5046
Number Of The Edition : 1.6

CUSTOMER'S APPROVED SIGNATURE		



志豐電子股份有限公司 KINGSTATE ELECTRONICS CORP.

Address: 10F, No. 69-11, Sec. 2, Chung Cheng E. Rd., Tamshui County, Taipei Hsien, Taiwan, R.O.C.

International sales dept.: TEL: 886-2-2809-5651 FAX: 886-2-2809-7151

Domestic sales dept.: TEL: 886-2-2809-0668 FAX: 886-2-28096748

<http://www.kingstate.com.tw>

Approved by	Checked by	Issued by
 2017.09.22	 2017.09.22	SKYChen 09/22/17

A. SCOPE 範疇

This specification applies piezo audio transducer, **KMTG1203**

此規格書適用於壓電式蜂鳴器, **KMTG1203**

B. SPECIFICATION 規格

No.	Item	Unit	Specification	Condition
1	Operating Volt. Range 最大操作電壓	Vp-p	MAX 25	
2	Current consumption 消耗電流	mA	MAX 5.0	at 5Vp-p,square wave,4.0KHz.
3	Sound pressure level 輸出音壓	dB	MIN 81	at 10cm/5Vp-p,square wave,4.0KHz
4	Electrostatic capacity 靜電容量	pF	16,000 ± 30%	at 120Hz/1V
5	Operating temp. 操作溫度	°C	-40 ~ +120	
6	Storage temp. 儲存溫度	°C	-40 ~ +120	
7	Dimension 尺寸	mm	L12.0 x W12.0 x H3.0	See appearance drawing 請參照外觀尺寸圖
8	Weight (MAX) 重量	gram	0.50	
9	Material 材質		LCP (Black)	
10	Terminal 端子		SMD type (鍍全錫/Plating Sn)	See appearance drawing 請參照外觀尺寸圖
11	Environmental Protection Regulation 環保法規		HSF	
12	Storage life 保存期限	month	6	6 months preservation at room temp.(25±3°C), Humidity40% 在室溫下25±3°C,濕度40%以下可保存6個月.
13	MSL 濕敏指數		2	

C. APPEARANCE DRAWING 外觀尺寸圖

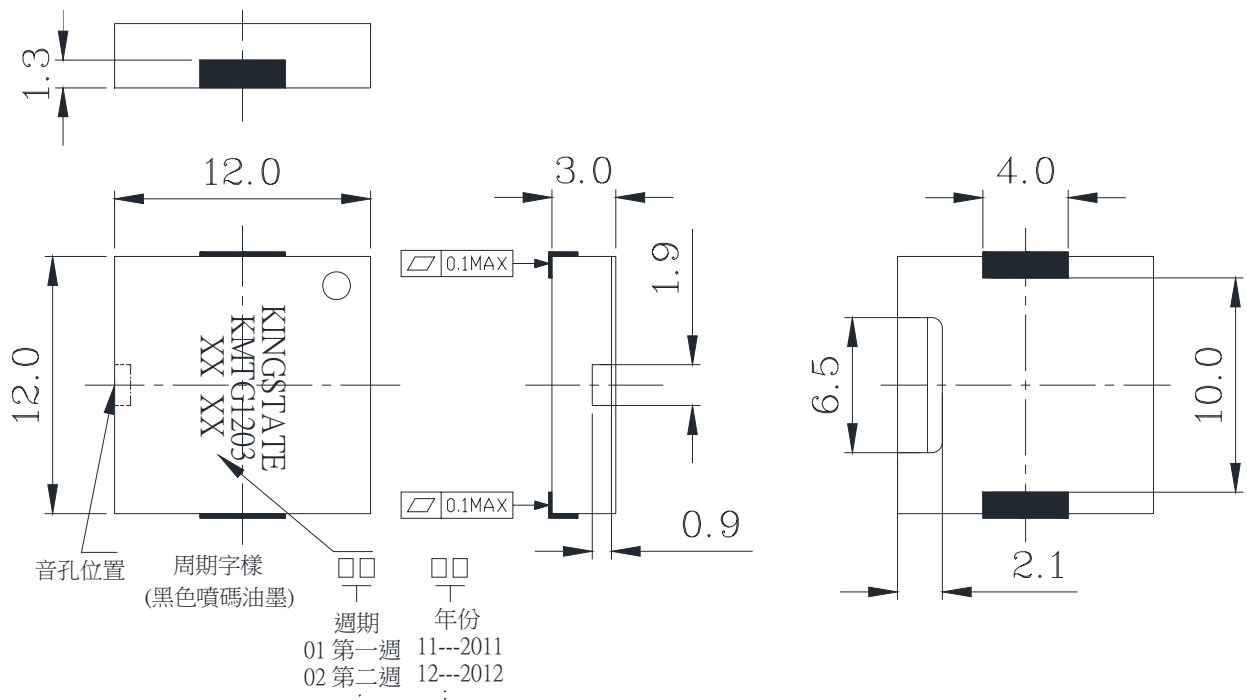

Tol: ± 0.3
Unit: mm

D. TYPICAL FREQUENCY RESPONSE CURVE 頻率響應曲線

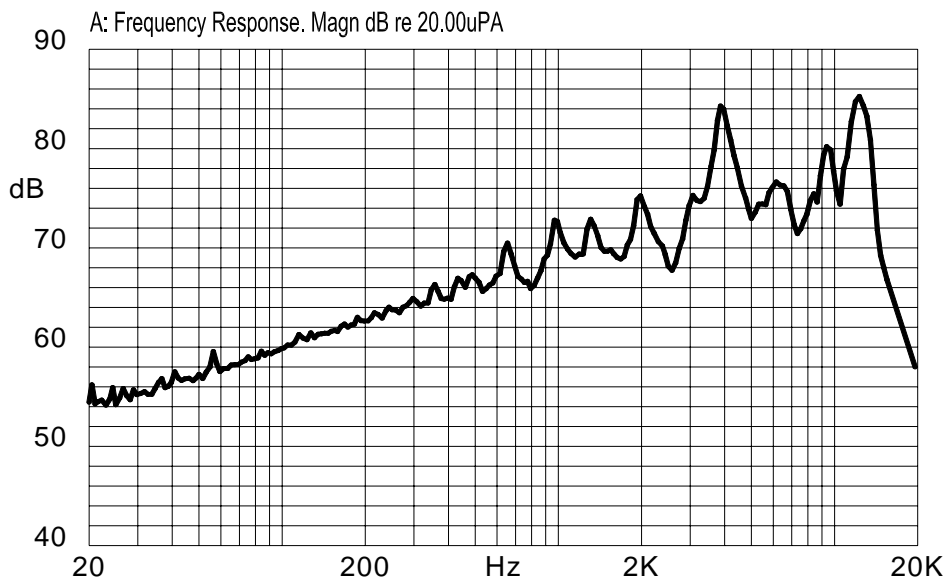

E. MEASURING METHOD 測量方法

S.P.L. Measuring Circuit 音壓測試接線圖

Input Signal: 5Vp-p,4.0kHz, Square Wave 輸入信號: 5Vp-p,4.0kHz, 方波

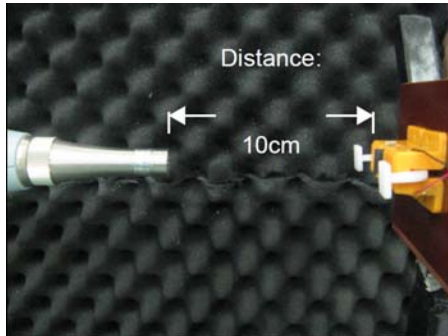
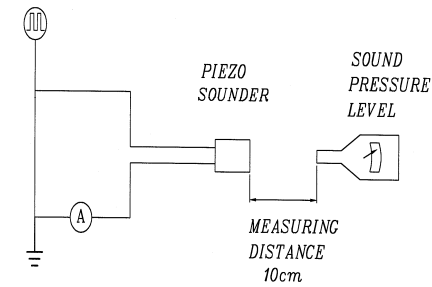

Mic : RION S.P.L meter UC30 or equivalent

Mic : RION 噪音計 UC30 或同等品

S.G : Hewlett Packard 33120A Function Generator or equivalent

S.G : Hewlett Packard 33120A 函數信號產生器或同等品

F. MECHANICAL CHARACTERISTICS 機械特性

No.	Item	Test Condition	Evaluation standard
1	Solderability 焊錫附著性	Lead terminals are immersed in solder bath of +350±5°C for 3±1 second. 端子置於錫膏內,錫膏溫度:+350±5°C. 焊接時間: 3±1 秒.	95% surface of lead pads must be covered with fresh solder 錫膏須覆蓋端子上方 95%
2	Soldering Heat Resistance 焊錫耐熱性	The product is followed the reflow temperature curve to test its reflow thermo stability. 產品依照迴焊溫度曲線測試迴焊耐熱性.	No interference in operation. 操作上無任何不良.
3	Terminal Mechanical Strength 端子強度	Lead pads shall be soldered on the pc board, and the force 9.8N(1.0kg) shall be applied behind the part for 10 seconds. 將端子焊在 PC 板上後, 對單體施以 9.8N(1.0kg)拉力 10 秒.	No damage and cutting off 端子不鬆動, 不脫落
4	Vibration 振動試驗	Buzzer shall be measured after being applied vibration of amplitude of 1.5mm with 10 to 55hz band of vibration frequency to each of 3 per-pendicular directions for 2 hours. 振動週波數 10~55HZ、全振幅 1.5mm 於 X.Y.Z 3 個方向,各 2 小時.	The value of oscillation frequency/ current consumption should be in ±10% compared with initial ones .The SPL should be in ±10dB compared with initial one.
5	Drop test 落下測試	The part only shall be dropped from a height of 75cm onto a 40mm thick wooden board 3 times in 3 axes (X.Y.Z). (a total of 9 times). 單體從 75 公分高處, X.Y.Z 3 個方向,各 3 回,落於 40mm 厚木板上.	諧振頻率與消耗電流變化量須在 ±10%內. 輸出音壓變化量須在 ±10dB 內.
6	Temperature tolerance of Conductive Silver Paste 導電銀漿耐溫性	Conductive Silver Paste curing at 150°C and then it can bear temperature less than 260°C. 導電銀漿在 150°C 下固化後最高可承受 260°C	No interference in operation. 操作上無任何不良.
7	Survivability of Reflow process 迴流焊次數	Buzzer cannot through reflow process more than 2 times and please reference Temperature profile as figure 'G. Recommended Temperature Profile For Reflow Oven ' is recommended. 依照“建議迴焊爐溫度曲線”圖, 最多可承受兩次迴流焊	No interference in operation. 操作上無任何不良.

G. Recommended Temperature Profile For Reflow Oven

建議迴焊爐溫度曲線

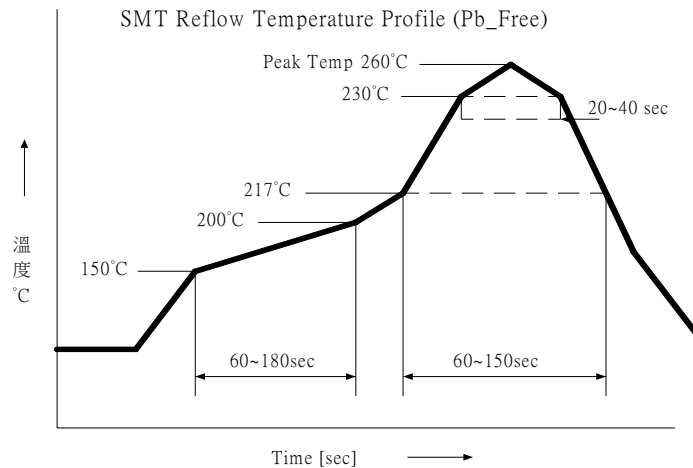

H. Recommended land pattern 建議基板設計尺寸圖

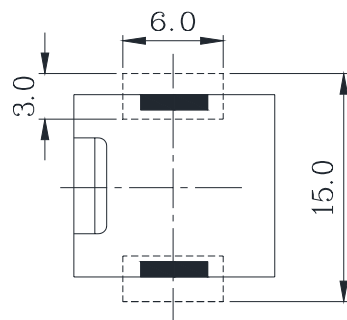

Recommendable Land Pattern

I. ENVIRONMENT TEST 環境測試

No.	Item	Test Condition	Evaluation standard
1	High temp. test 高溫測試	After being placed in a chamber at +120°C for 240 hours 置於+120°C環境中 240 小時	Being placed for 4 hours at +25°C, buzzer shall be measured. The value of oscillation frequency/ current consumption should be in ±10% compared with initial ones. The SPL should be in ±10dB compared with initial one. 經測試後，靜置於+25°C（室溫）環境中 4 小時後，諧振頻率與消耗電流變化量須在±10%內。輸出音壓變化量須在±10dB 內。
2	Low temp. test 低溫測試	After being placed in a chamber at -40°C for 240 hours 置於-40°C環境中 240 小時	
3	Humidity test 相對濕度測試	After being placed in a chamber at +40°C and 90±5% relative humidity for 240 hours 置於+40°C，相對濕度 90±5% 環境中 240 小時	
4	Temp. cycle test 溫度循環試驗	The part shall be subjected to 5 cycles. One cycle shall be consist of: 單體承受溫度循環測試 5 次，其循環內容如圖示： 	

J. RELIABILITY TEST 信賴性測試

No.	Item	Test condition	Evaluation standard
1	Operating life test 壽命測試	<p>1. Continuous life test 高溫壽命測試(連續) 48 hours continuous operation at +55°C with rated voltage applied. 在+55°C環境下,以額定電壓連續操作 48 小時.</p> <p>2. Intermittent life test 室溫壽命測試(間歇) A duty cycle of 1 minute on, minutes off, a minimum of 5000 times at room temp. (+25 ±2°C) and rated voltage applied. 在室溫下(+25 ±2°C), 以額定電壓操作, 通電 1 分鐘/斷電 1 分鐘, 測試 5000 次循環.</p>	<p>Being placed for 4 hours at +25°C, buzzer shall be measured. The value of oscillation frequency/ current consumption should be in ±10% compared with initial ones. The SPL should be in ±10dB compared with initial one.</p> <p>經測試後, 靜置於+25°C (室溫) 環境中 4 小時後, 諧振頻率與消耗電流變化量須在±10%內. 輸出音壓變化量須在±10dB 內.</p>

TEST CONDITION.

Standard Test Condition	:	a) Temperature : +5 ~ +35°C	b) Humidity : 45-85%	c) Pressure : 860-1060mbar
一般測試條件	:	a) 溫度 : +5 ~ +35°C	b) 濕度 : 45-85%	c) 氣壓 : 860-1060mbar
Judgement Test Condition	:	a) Temperature : +25 ±2°C	b) Humidity : 60-70%	c) Pressure : 860-1060mbar
爭議時測試條件	:	a) 溫度 : +25 ±2°C	b) 濕度 : 60-70%	c) 氣壓 : 860-1060mbar

K. PACKING STANDARD 包裝規格

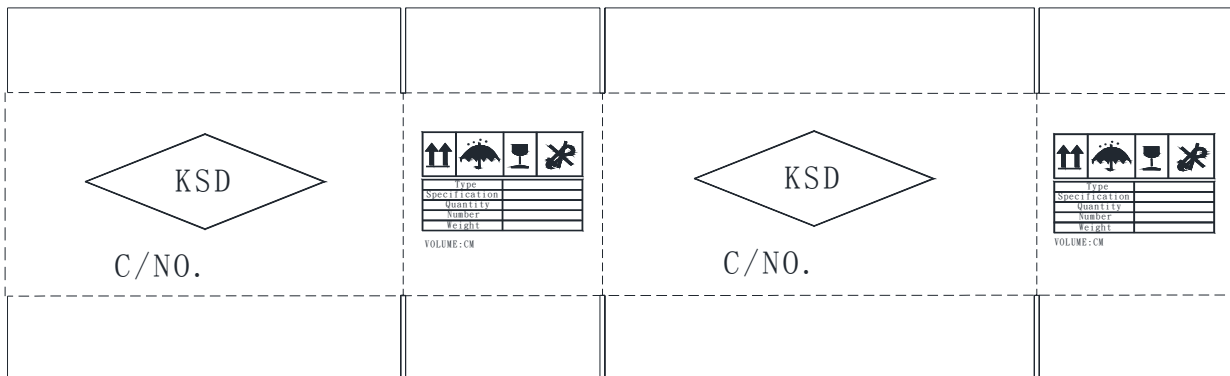

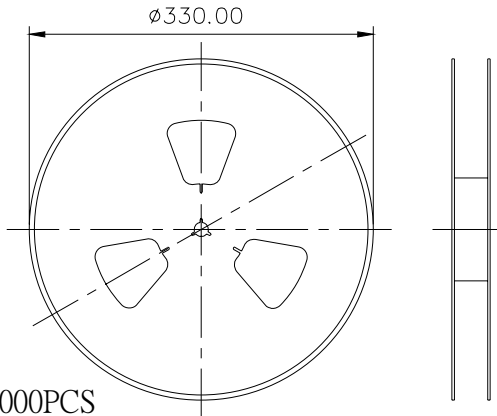
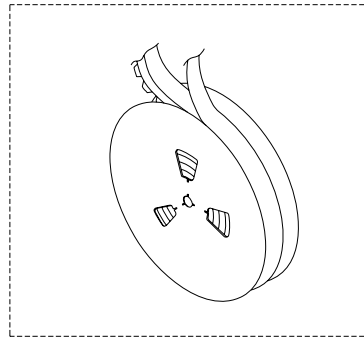
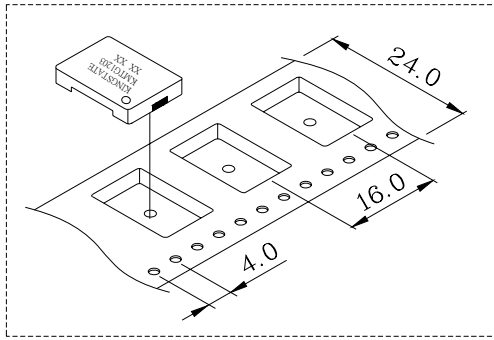

1 Reel: 1000PCS

Carton Box
(5 Inner Box)

Inner Box
(1 Layer Reel)

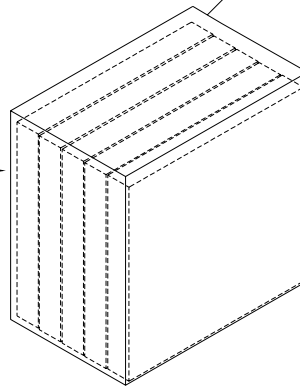
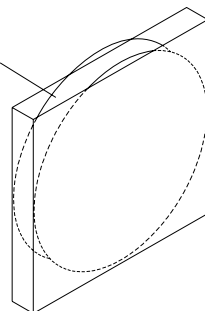

Inner Box	340mmx340mmx35mm	1x1000PCS=1000PCS
Carton Box	350mmx195mmx355mm	5x1000PCS=5,000PCS

Lot No.	XXXXXXXXXX
Part No.	XXXXXXXXXX
Quantity	XXXX PCS
Date:	DD MM YY
	HSF
KINGSTATE ELECTRONICS CORP.	

* The label stuck on Inner boxes and the outer of carton.

Caution
This bag contains
MOISTURE-SENSITIVE DEVICES

- Calculated shelf life in sealed bag: 12 months at +40°C and $\leq 90\%$ relative humidity (RH)
- Peak package body temperature: _____ °C
- After bag is opened, devices that will be subjected to reflow solder or other high temperature process must be:
 - Mounted within: _____ hours of factory conditions:
 - ≤ 30 D160% RH, or
 - Stored per J-STD-033
- Devices require bake, before mounting, if:
 - Humidity Indicator Card reads $>10\%$ for level 2a - 5a devices or $>60\%$ for level 2 devices when read at $23 \pm 5^\circ\text{C}$
 - 2a or 3b are not met
- If baking is required, refer to IPC/JEDEC J-STD-033 for bake procedure.

Bag Seal Date: _____

Note: Level and body temperature defined by IPC/JEDEC J-STD-033

Date	PRC	QTY	PIN	INITIAL



真空包裝袋 / 內附干燥劑 / HIC 卡
外貼MSD 標貼 / 符合MSL-2