

# OPTIREG™ linear TLS850F3TUV50

Low dropout linear voltage regulator with watchdog and reset



## Features

- Output voltage 5 V  $\pm$ 2%
- Current capability 500 mA
- Input voltage range from 3 V to 42 V
- Stable with 1  $\mu$ F ceramic output capacitor
- Ultra low current consumption: typically 26  $\mu$ A
- Very low drop out voltage: typically 300 mV at 250 mA
- Watchdog circuit for monitoring a microprocessor
- Watchdog inhibit
- Output voltage supervision by reset circuit:
  - Programmable delay time
- Output current limitation
- Overtemperature shutdown
- Green Product (RoHS compliant)

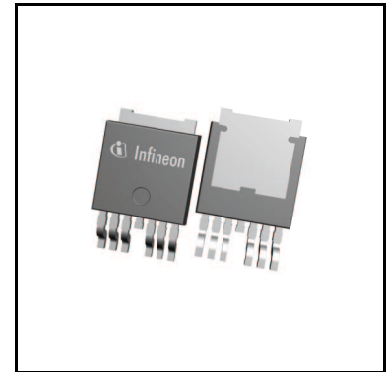

## Potential applications

- Automotive general ECUs
- Telematics systems
- ADAS cameras and radar systems
- Navigation systems
- Body control modules

## Product validation

Qualified for automotive applications. Product validation according to AEC-Q100.

## Description

The OPTIREG™ linear TLS850F3TUV50 is a high performance low drop out fixed output voltage regulator in a PG-TO252-7 package. With an input voltage range of 3 V to 42 V and very low quiescent current of only 26  $\mu$ A, these regulators are perfectly suitable for automotive systems or other supply systems connected to the battery permanently. The TLS850F3TUV50 provides an output voltage accuracy of  $\pm 2\%$  and a maximum output current of 500 mA.

The loop concept combines fast regulation and very good stability while requiring only one small ceramic capacitor of 1  $\mu$ F at the output. The operating range starts already at an input voltage of only 3 V (extended operating range). This makes the TLS850F3TUV50 also suitable to supply automotive systems that need to operate during cranking condition.

The **Reset** supervises the output voltage, including undervoltage reset and delay reset at power-on.

An integrated **Watchdog** circuit with adjustable timing monitors the microcontroller's operation. A shared external delay capacitor sets both reset timing and watchdog timing.

Internal protection features such as output current limitation and overtemperature shutdown are implemented to protect the device against immediate damage due to failures such as output short circuit to GND, overcurrent and overtemperature.

| Type          | Package    | Marking |
|---------------|------------|---------|
| TLS850F3TUV50 | PG-TO252-7 | 850F3V5 |

## Table of contents

|          |   |           |
|----------|---|-----------|
|          | <b>Features</b> .....   | <b>1</b>  |
|          | <b>Potential applications</b> .....                           | <b>1</b>  |
|          | <b>Product validation</b> .....                               | <b>1</b>  |
|          | <b>Description</b> .....                                      | <b>2</b>  |
|          | <b>Table of contents</b> .....                                | <b>3</b>  |
| <b>1</b> | <b>Block diagram</b> .....                                    | <b>4</b>  |
| <b>2</b> | <b>Pin configuration</b> .....                                | <b>5</b>  |
| 2.1      | Pin assignment .....  | 5         |
| 2.2      | Pin definitions and functions .....                           | 5         |
| <b>3</b> | <b>General product characteristics</b> .....                  | <b>6</b>  |
| 3.1      | Absolute maximum ratings .....                                | 6         |
| 3.2      | Functional range .....  | 7         |
| 3.3      | Thermal resistance .....                                      | 8         |
| <b>4</b> | <b>Block description and electrical characteristics</b> ..... | <b>9</b>  |
| 4.1      | Voltage regulator .....                                       | 9         |
| 4.1.1    | Electrical characteristics voltage regulator .....            | 10        |
| 4.1.2    | Typical performance characteristics voltage regulator .....   | 12        |
| 4.2      | Current consumption .....                                     | 15        |
| 4.2.1    | Typical performance characteristics current consumption ..... | 16        |
| 4.3      | Reset .....   | 17        |
| 4.3.1    | Electrical characteristics reset .....                        | 20        |
| 4.3.2    | Typical performance characteristics reset .....               | 21        |
| 4.4      | Watchdog .....  | 23        |
| 4.4.1    | Electrical characteristics watchdog .....                     | 26        |
| 4.4.2    | Typical performance characteristics watchdog .....            | 28        |
| <b>5</b> | <b>Application information</b> .....                          | <b>30</b> |
| 5.1      | Application diagram .....                                     | 30        |
| 5.2      | Selection of external components .....                        | 30        |
| 5.2.1    | Input pin .....   | 30        |
| 5.2.2    | Output pin .....  | 30        |
| 5.3      | Thermal considerations .....                                  | 31        |
| 5.4      | Reverse polarity protection .....                             | 31        |
| 5.5      | Further application information .....                         | 32        |
| <b>6</b> | <b>Package information</b> .....                              | <b>33</b> |
| <b>7</b> | <b>Revision history</b> .....                                 | <b>34</b> |

**Block diagram**

**1 Block diagram**

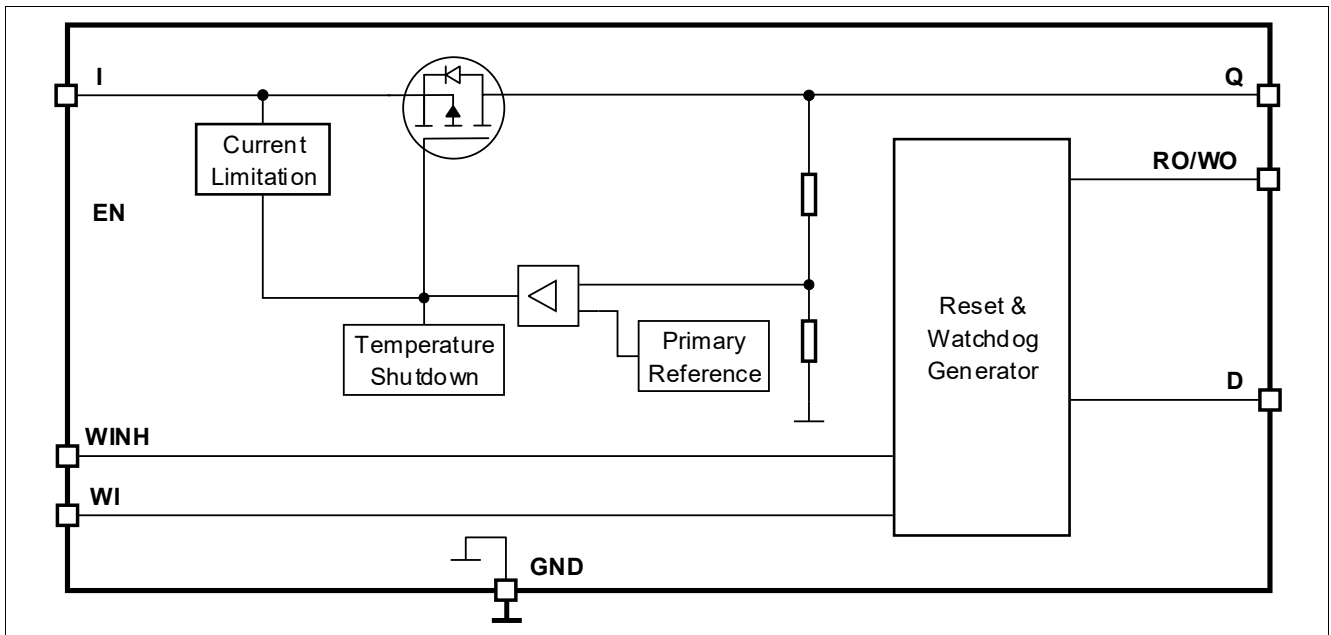
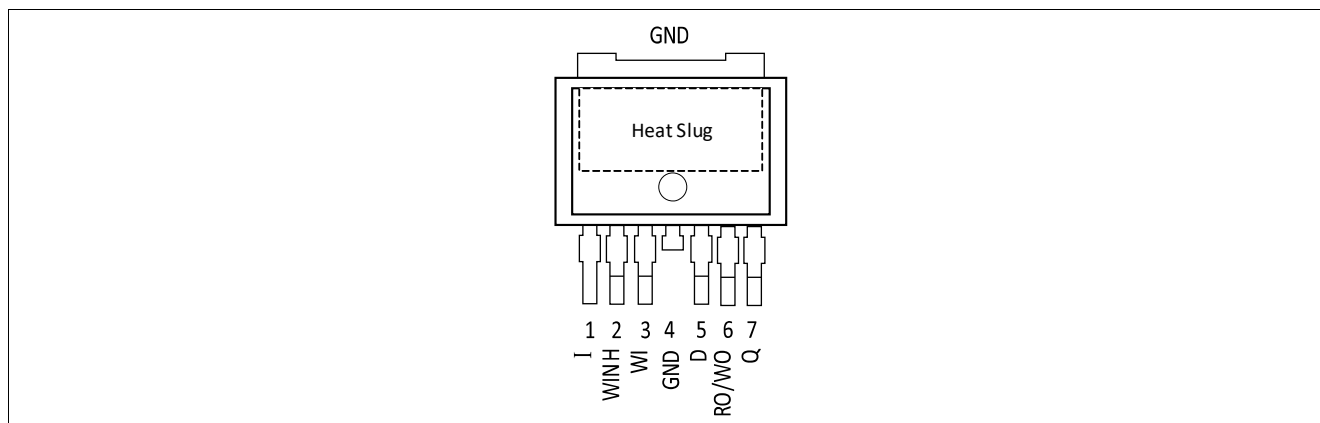

**Figure 1 Block diagram**

**Pin configuration**

## 2 Pin configuration

### 2.1 Pin assignment



**Figure 2 Pin assignment PG-T0252-7**

### 2.2 Pin definitions and functions

| Pin | Symbol | Function  |
|-----|--------|---|
| 1   | I      | <b>Input</b><br>It is recommended to connect a small ceramic capacitor from this pin to GND, close to the pins, in order to compensate line influences.   |
| 2   | WINH   | <b>Watchdog inhibit input</b><br>“Low” activates the watchdog function.<br>“High” deactivates the watchdog function.<br>This pin has an integrated pull-down resistor.                                    |
| 3   | WI     | <b>Watchdog input</b><br>Serve watchdog with trigger input signal (usable for microcontroller monitoring).<br>This pin has an integrated pull-down resistor.  |
| 4   | GND    | <b>Ground</b>   |
| 5   | D      | <b>Delay input</b><br>Connect an external capacitor from this pin to GND to set reset timing and watchdog timing. If no capacitor is placed, then disable the watchdog.                                   |
| 6   | RO/WO  | <b>Reset output/Watchdog output</b><br>This pin has an integrated pull-up resistor to Q. It is an open collector output.<br>If the reset and watchdog functions are not needed, then leave this pin open. |
| 7   | Q      | <b>Regulator output</b><br>Connect the output capacitor $C_Q$ from this pin to GND close to the pin, respecting the values specified for its capacitance and ESR in <b>Functional range</b> .             |
| Pad | –      | <b>Exposed pad</b><br>Connect the exposed pad to a heatsink area.<br>Connect the exposed pad to GND.  |

General product characteristics

### 3 General product characteristics

#### 3.1 Absolute maximum ratings

**Table 1 Absolute maximum ratings<sup>1)</sup>**

$T_j = -40^\circ\text{C}$  to  $150^\circ\text{C}$ ; all voltages with respect to ground, positive current flowing into pin (unless otherwise specified)

| Parameter                       | Symbol        | Values |      |      | Unit | Note or Test Condition                 | Number   |
|---------------------------------|---------------|--------|------|------|------|--|----------|
|                                 |               | Min.   | Typ. | Max. |      |  |          |
| <b>Voltage rating</b>           |               |        |      |      |      |  |          |
| Input voltage I                 | $V_I$         | -0.3   | –    | 45   | V    | –                                      | P_3.1.15 |
| Output voltage Q                | $V_Q$         | -0.3   | –    | 7    | V    | –                                      | P_3.1.16 |
| Reset output RO/WO              | $V_{RO/WO}$   | -0.3   | –    | 7    | V    | –                                      | P_3.1.17 |
| Delay voltage D                 | $V_D$         | -0.3   | –    | 7    | V    | –                                      | P_3.1.18 |
| Watchdog input WI               | $V_{WI}$      | -0.3   | –    | 7    | V    | –                                      | P_3.1.19 |
| Watchdog inhibit WINH           | $V_{WINH}$    | -0.3   | –    | 7    | V    | –                                      | P_3.1.20 |
| <b>Temperature</b>              |               |        |      |      |      |  |          |
| Junction temperature            | $T_j$         | -40    | –    | 150  | °C   | –                                      | P_3.1.21 |
| Storage temperature             | $T_{stg}$     | -55    | –    | 150  | °C   | –                                      | P_3.1.22 |
| <b>ESD robustness</b>           |               |        |      |      |      |  |          |
| ESD robustness to GND           | $V_{ESD,HBM}$ | -2     | –    | 2    | kV   | <sup>2)</sup> HBM all pins             | P_3.1.23 |
| ESD robustness to GND           | $V_{ESD,CDM}$ | -500   | –    | 500  | V    | <sup>3)</sup> CDM all pins except 1, 7 | P_3.1.24 |
| ESD robustness pins 1, 7 to GND | $V_{ESD}$     | -750   | –    | 750  | V    | <sup>3)</sup> CDM                      | P_3.1.25 |

1) Not subject to production test, specified by design.

2) Human body model (HBM) robustness according to AEC-Q100-002.

3) Charged device model (CDM) robustness according to AEC-Q100-011 Rev-D; voltage level refers to test condition (TC) mentioned in the standard.

#### Notes

1. Stresses above the ones listed here may cause permanent damage to the device. Exposure to absolute maximum rating conditions for extended periods may affect device reliability.
2. Integrated protection functions are designed to prevent IC destruction under fault conditions described in the data sheet. Fault conditions are considered as “outside” normal operating range. Protection functions are not designed for continuous repetitive operation.
3. Latchup robustness: class II according to AEC - Q100-04.

**General product characteristics**

**3.2 Functional range**

**Table 2 Functional range**

$T_j = -40^\circ\text{C}$  to  $150^\circ\text{C}$ ; all voltages with respect to ground, positive current flowing into pin (unless otherwise specified)

| Parameter                               | Symbol       | Values               |      |      | Unit | Note or Test Condition | Number  |
|---|--------------|----------------------|------|------|------|------------------------|---------|
|   |              | Min.                 | Typ. | Max. |      |                        |         |
| Input voltage range                     | $V_I$        | $V_{Q,nom} + V_{dr}$ | –    | 42   | V    | 1)                     | P_3.2.1 |
| Extended input voltage range            | $V_{I(ext)}$ | 3                    | –    | 42   | V    | 2)                     | P_3.2.2 |
| Junction temperature                    | $T_j$        | -40                  | –    | 150  | °C   | –                      | P_3.2.4 |
| Output capacitance for stable operation | $C_Q$        | 1                    | –    | –    | μF   | 3)4)                   | P_3.2.5 |
| ESR of output capacitor                 | $ESR_{CQ}$   | –                    | –    | 20   | Ω    | 4)5)                   | P_3.2.6 |

- 1) See the values of output voltage  $V_Q$  and drop out voltage  $V_{dr}$ , in **Voltage regulator**.
- 2) The output voltage  $V_Q$  follows the input voltage, but is outside the specified range, see **Voltage regulator**.
- 3) The minimum output capacitance requirement is applicable for a worst case capacitance tolerance of 30%.
- 4) Not subject to production test, specified by design.
- 5) Relevant ESR value at  $f = 10$  kHz.

*Note: Within the functional range the IC operates as described in the circuit description. The electrical characteristics are specified within the conditions given in the related electrical characteristics table.*

**General product characteristics**

**3.3 Thermal resistance**

Note: This thermal data was generated in accordance with JEDEC JESD51 standards. For more information, go to [www.jedec.org](http://www.jedec.org).

**Table 3 Thermal resistance**

| Parameter           | Symbol     | Values |      |      | Unit | Note or Test Condition                                   | Number   |
|---------------------|------------|--------|------|------|------|--|----------|
|                     |            | Min.   | Typ. | Max. |      |  |          |
| Junction to case    | $R_{thJC}$ | –      | 3    | –    | K/W  | <sup>1)</sup>  | P_3.3.6  |
| Junction to ambient | $R_{thJA}$ | –      | 112  | –    | K/W  | <sup>1)2)</sup> Footprint only                           | P_3.3.7  |
| Junction to ambient | $R_{thJA}$ | –      | 66   | –    | K/W  | <sup>1)2)</sup> 300 mm <sup>2</sup> heatsink area on PCB | P_3.3.8  |
| Junction to ambient | $R_{thJA}$ | –      | 50   | –    | K/W  | <sup>1)2)</sup> 600 mm <sup>2</sup> heatsink area on PCB | P_3.3.9  |
| Junction to ambient | $R_{thJA}$ | –      | 30   | –    | K/W  | <sup>1)3)</sup> 2s2p PCB                                 | P_3.3.10 |

- 1) Not subject to production test, specified by design.
- 2) Specified  $R_{thJA}$  value is according to JEDEC JESD51-3 at natural convection on FR4 1s0p board; The Product (chip and package) was simulated on a 76.2 × 114.3 × 1.5 mm<sup>3</sup> board with 1 inner copper layer (1 × 70 μm Cu).
- 3) Specified  $R_{thJA}$  value is according to JEDEC JESD51-2,-5,-7 at natural convection on FR4 2s2p board; The Product (chip and package) was simulated on a 76.2 × 114.3 × 1.5 mm<sup>3</sup> board with 2 inner copper layers (2 × 70 μm Cu, 2 × 35 μm Cu). Where applicable a thermal via array under the exposed pad contacted the first inner copper layer.



## **4 Block description and electrical characteristics**

### **4.1 Voltage regulator**

A resistor network divides the output voltage  $V_Q$ . The device compares this fractional voltage to an internal voltage reference and drives the pass transistor accordingly.

The control loop stability depends on the following factors:

- Output capacitor
- Load current  $I_Q$
- Chip temperature  $T_j$
- Internal circuit design

#### **Output capacitor**

To ensure stable operation, the capacitance of the output capacitor  $C_Q$  and its equivalent series resistor  $ESR_{CQ}$  requirements must be maintained, see [Functional range](#). The output capacitor must be sized according to the requirements of the application, for example to buffer steps in the load current  $I_Q$ .

#### **Input capacitors, reverse polarity protection diode**

An input capacitor  $C_I$  is recommended to compensate line influences. In order to block influences, such as pulses and high frequency distortion at the input, use a reverse polarity protection diode and a combination of several capacitors. Connect the capacitors close to the component's terminals.

#### **Smooth ramp-up**

In order to prevent overshoot during startup, a smooth ramp-up function is implemented. This ensures a reduced output voltage overshoot during startup, mostly independent from load and output capacitor.

#### **Output current limitation**

Due to a short circuit or overload condition the load current can exceed the specified limit. In this case the device limits the output current and the output voltage decreases.

#### **Overtemperature shutdown**

The overtemperature shutdown circuit prevents the device from immediate destruction in case of a fault condition, for example due to a permanent short circuit at the output. In such a condition the overtemperature shutdown circuit switches off the device. After the device cools down, the regulator restarts. This leads to an oscillatory behavior of the output voltage  $V_Q$ . However, any junction temperature above 150°C is outside the maximum ratings and therefore significantly reduces the lifetime of the device.

Block description and electrical characteristics

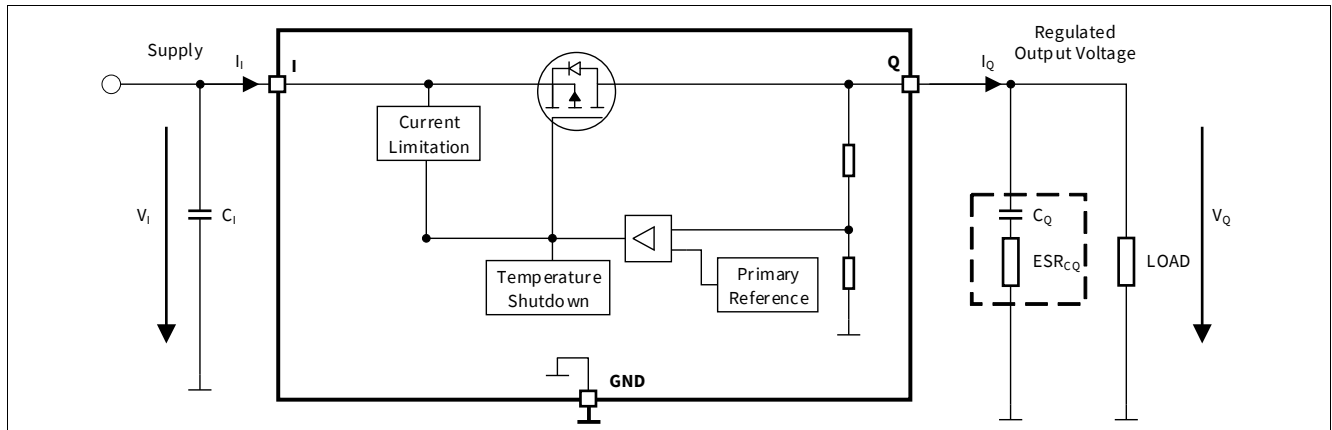

Figure 3 Functional block diagram voltage regulator circuit

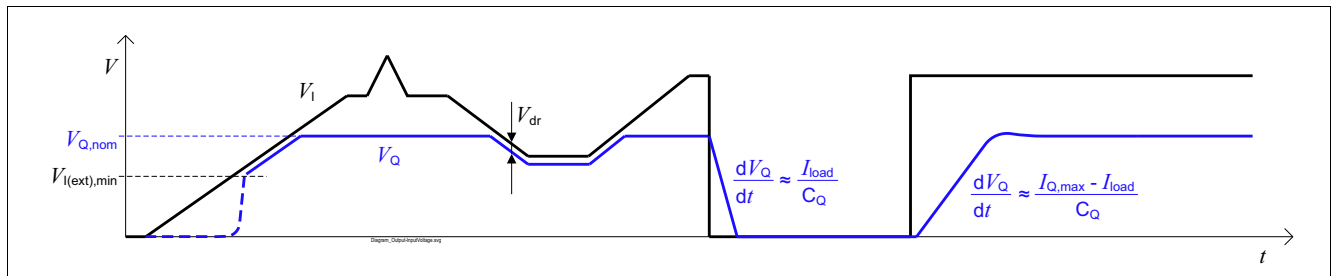

Figure 4 Output voltage versus input voltage

4.1.1 Electrical characteristics voltage regulator

Table 4 Electrical characteristics voltage regulator

$V_i = 13.5\text{ V}$ ;  $T_j = -40^\circ\text{C}$  to  $150^\circ\text{C}$ ; all voltages with respect to ground, direction of currents as shown in **Figure 3** (unless otherwise specified)

| Parameter                        | Symbol                | Values |      |      | Unit | Note or Test Condition   | Number   |
|----------------------------------|-----------------------|--------|------|------|------|--|----------|
|                                  |                       | Min.   | Typ. | Max. |      |  |          |
| Output voltage accuracy          | $V_Q$                 | 4.9    | 5.0  | 5.1  | V    | $50\ \mu\text{A} \leq I_Q \leq 200\ \text{mA}$ ;<br>$V_{Q,nom} + V_{dr} \leq V_i \leq 42\ \text{V}$                  | P_4.1.1  |
| Output voltage accuracy          | $V_Q$                 | 4.9    | 5.0  | 5.2  | V    | $I_Q \leq 50\ \mu\text{A}$ ;<br>$V_{Q,nom} + V_{dr} \leq V_i \leq 42\ \text{V}$                                      | P_4.1.5  |
| Output voltage accuracy          | $V_Q$                 | 4.9    | 5.0  | 5.1  | V    | $50\ \mu\text{A} \leq I_Q \leq 500\ \text{mA}$ ;<br>$V_{Q,nom} + V_{dr} \leq V_i \leq 28\ \text{V}$                  | P_4.1.8  |
| Output voltage startup slew rate | $\Delta V_Q/\Delta t$ | 7      | -    | 70   | V/ms | $\Delta V_i/\Delta t = 50\ \text{V/ms}$ ;<br>$C_Q = 1\ \mu\text{F}$ ;<br>$0.5\ \text{V} \leq V_Q \leq 4.5\ \text{V}$ | P_4.1.10 |
| Load regulation steady state     | $\Delta V_{Q,load}$   | -15    | -5   | 5    | mV   | $I_Q = 0.05\ \text{mA}$ to $500\ \text{mA}$ ;<br>$V_i = 6.5\ \text{V}$   | P_4.1.13 |
| Line regulation steady state     | $\Delta V_{Q,line}$   | -5     | 1    | 10   | mV   | $V_i = 8\ \text{V}$ to $32\ \text{V}$ ;<br>$I_Q = 5\ \text{mA}$  | P_4.1.14 |
| Power supply ripple rejection    | PSRR                  | -      | 60   | -    | dB   | <sup>2)</sup> $f_{ripple} = 100\ \text{Hz}$ ;<br>$V_{ripple} = 0.5\ \text{V}_{pp}$ ;<br>$I_Q = 10\ \text{mA}$        | P_4.1.15 |

**Block description and electrical characteristics**

**Table 4 Electrical characteristics voltage regulator (cont'd)**

$V_I = 13.5\text{ V}$ ;  $T_j = -40^\circ\text{C}$  to  $150^\circ\text{C}$ ; all voltages with respect to ground, direction of currents as shown in **Figure 3** (unless otherwise specified)

| Parameter                                     | Symbol      | Values |      |      | Unit | Note or Test Condition                              | Number   |
|---|-------------|--------|------|------|------|---|----------|
|   |             | Min.   | Typ. | Max. |      |   |          |
| Dropout voltage $V_{dr} = V_I - V_Q$          | $V_{dr}$    | –      | 125  | 350  | mV   | <sup>1)</sup> $I_Q = 100\text{ mA}$                 | P_4.1.21 |
| Dropout voltage $V_{dr} = V_I - V_Q$          | $V_{dr}$    | –      | 300  | 750  | mV   | <sup>1)</sup> $I_Q = 250\text{ mA}$                 | P_4.1.22 |
| Output current limitation                     | $I_{Q,max}$ | 501    | 700  | 1100 | mA   | $0\text{ V} \leq V_Q \leq V_{Q,nom} - 0.1\text{ V}$ | P_4.1.26 |
| Overtemperature shutdown threshold            | $T_{j,sd}$  | 151    | 175  | 200  | °C   | <sup>2)</sup> $T_j$ increasing                      | P_4.1.27 |
| Overtemperature shutdown threshold hysteresis | $T_{j,sdh}$ | –      | 15   | –    | K    | <sup>2)</sup> $T_j$ decreasing                      | P_4.1.28 |

1) Measured when the output voltage  $V_Q$  has dropped 100 mV from its nominal value obtained at  $V_I = 13.5\text{ V}$ .

2) Not subject to production test, specified by design.

4.1.2 Typical performance characteristics voltage regulator

Output voltage  $V_Q$  versus junction temperature  $T_j$

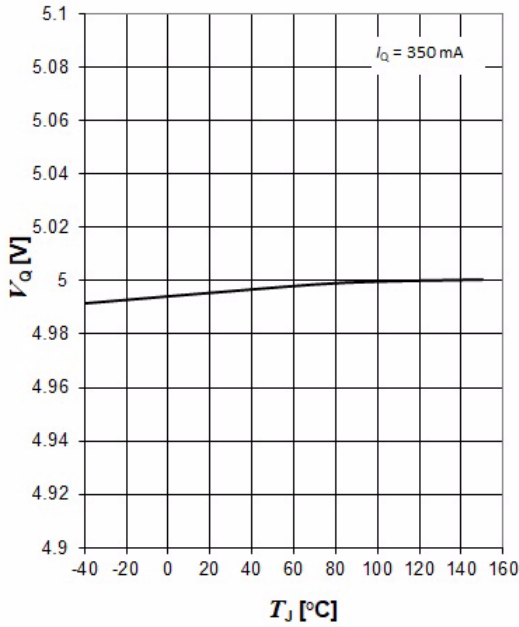

Output current limitation  $I_{Q,max}$  versus input voltage  $V_i$

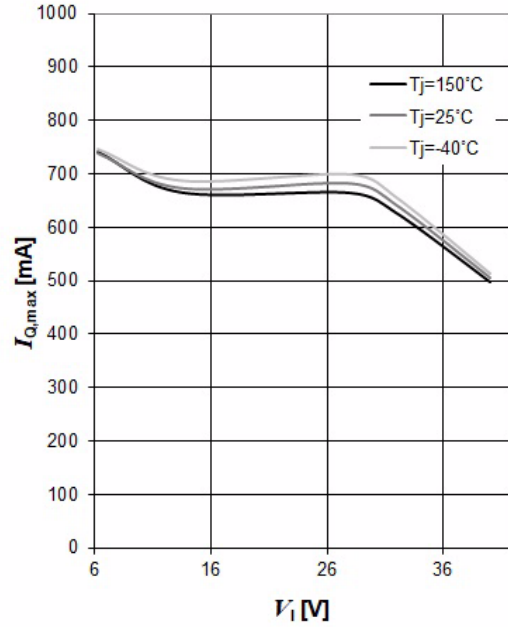

Dropout voltage  $V_{dr}$  versus junction temperature  $T_j$

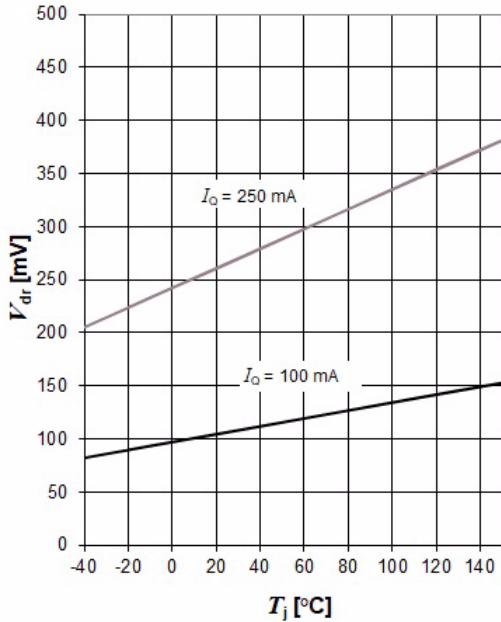

Dropout voltage  $V_{dr}$  versus output current  $I_Q$

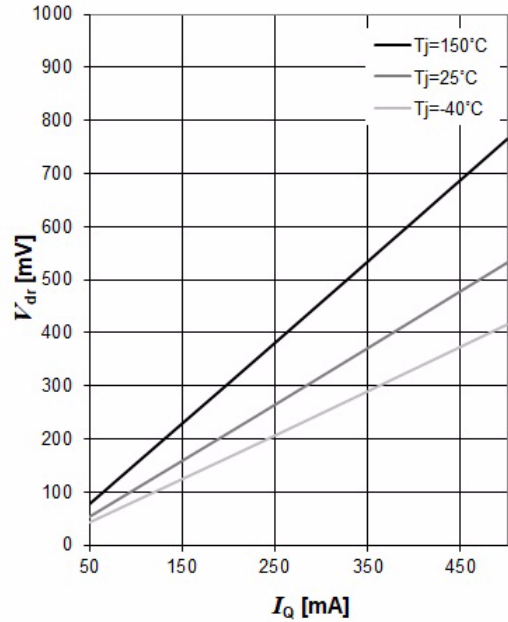

**Block description and electrical characteristics**

**Output voltage  $V_Q$  versus output current  $I_Q$**

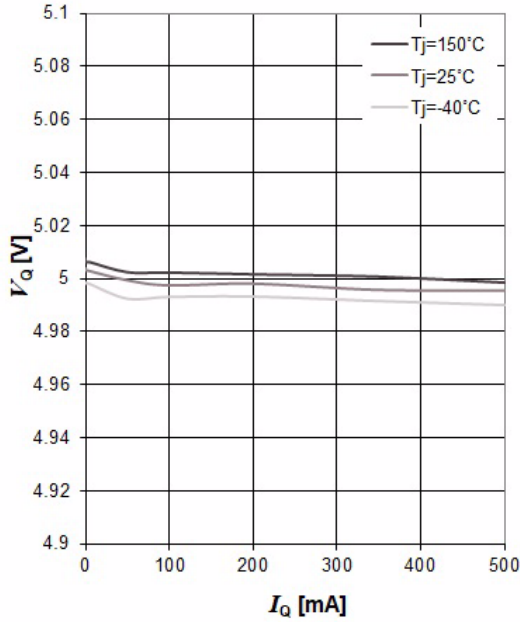

**Output voltage  $V_Q$  versus input voltage  $V_I$**

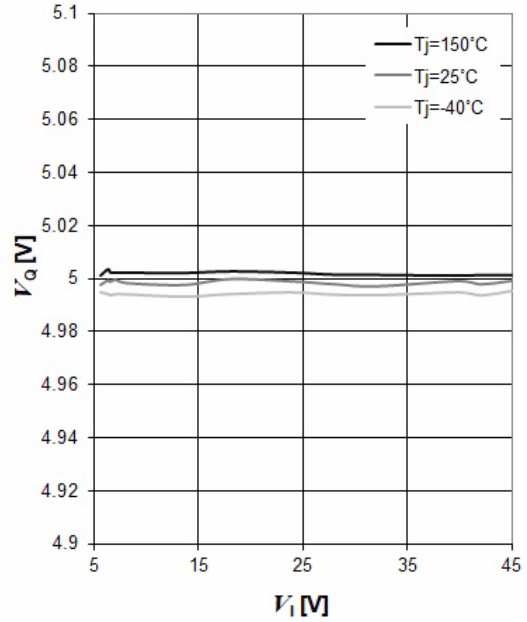

**Line regulation  $\Delta V_{Q,line}$  versus input voltage change  $\Delta V_I$**

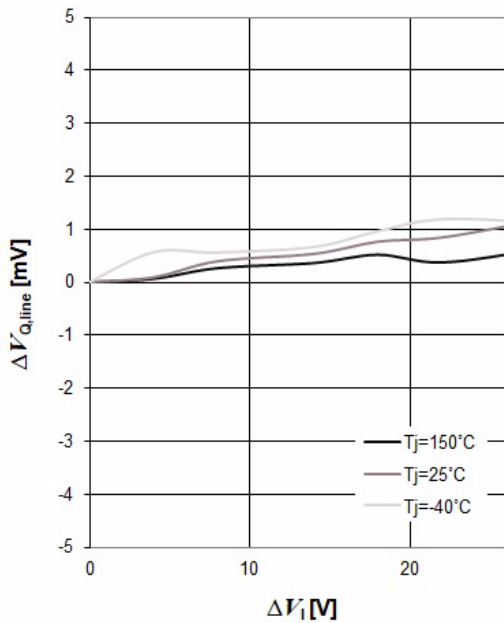

**Load regulation  $\Delta V_{Q,load}$  versus output current change  $\Delta I_Q$**

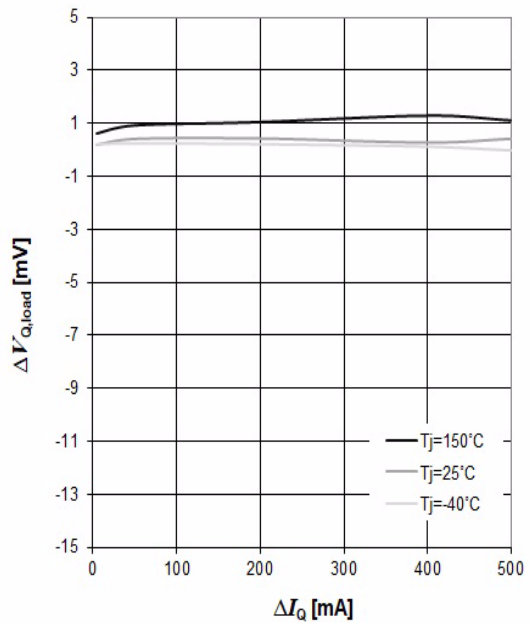

**Block description and electrical characteristics**

**Power supply ripple rejection *PSRR* versus frequency *f***

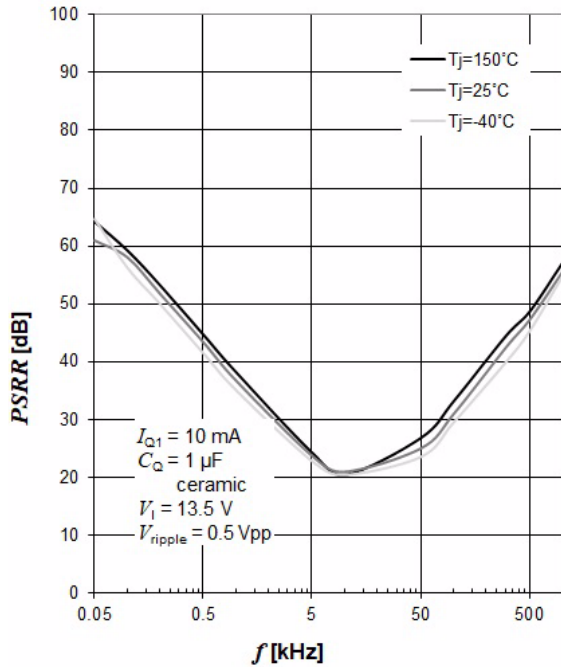

**Block description and electrical characteristics**

**4.2 Current consumption**

**Table 5 Electrical characteristics current consumption**

$V_I = 13.5\text{ V}$ ,  $T_j = -40^\circ\text{C}$  to  $150^\circ\text{C}$ ; all voltages with respect to ground; direction of currents see [Figure 5](#) (unless otherwise specified)

| Parameter                             | Symbol | Values |      |      | Unit          | Note or Test Condition   | Number   |
|---------------------------------------|--------|--------|------|------|---------------|--|----------|
|                                       |        | Min.   | Typ. | Max. |               |  |          |
| Current consumption $I_q = I_I - I_Q$ | $I_q$  | –      | 23   | 35   | $\mu\text{A}$ | $I_Q = 50\ \mu\text{A}$ ;<br>$T_j = 25^\circ\text{C}$ ;<br>watchdog disabled                 | P_4.2.4  |
| Current consumption $I_q = I_I - I_Q$ | $I_q$  | –      | 26   | 43   | $\mu\text{A}$ | $I_Q = 50\ \mu\text{A}$ ;<br>$T_j \leq 125^\circ\text{C}$ ;<br>watchdog disabled             | P_4.2.5  |
| Current consumption $I_q = I_I - I_Q$ | $I_q$  | –      | 29   | 51   | $\mu\text{A}$ | $I_Q = 50\ \mu\text{A}$ ;<br>$T_j \leq 150^\circ\text{C}$ ;<br>watchdog disabled             | P_4.2.6  |
| Current consumption $I_q = I_I - I_Q$ | $I_q$  | –      | 26   | 39   | $\mu\text{A}$ | $I_Q = 50\ \mu\text{A}$ ;<br>$T_j = 25^\circ\text{C}$ ;<br>watchdog enabled                  | P_4.2.7  |
| Current consumption $I_q = I_I - I_Q$ | $I_q$  | –      | 30   | 47   | $\mu\text{A}$ | $I_Q = 50\ \mu\text{A}$ ;<br>$T_j \leq 125^\circ\text{C}$ ;<br>watchdog enabled              | P_4.2.8  |
| Current consumption $I_q = I_I - I_Q$ | $I_q$  | –      | 33   | 55   | $\mu\text{A}$ | $I_Q = 50\ \mu\text{A}$ ;<br>$T_j \leq 150^\circ\text{C}$ ;<br>watchdog enabled              | P_4.2.9  |
| Current consumption $I_q = I_I - I_Q$ | $I_q$  | –      | 33   | 55   | $\mu\text{A}$ | <sup>1)</sup> $I_Q = 500\ \text{mA}$ ;<br>$T_j \leq 125^\circ\text{C}$ ;<br>watchdog enabled | P_4.2.11 |

1) Not subject to production test, specified by design.

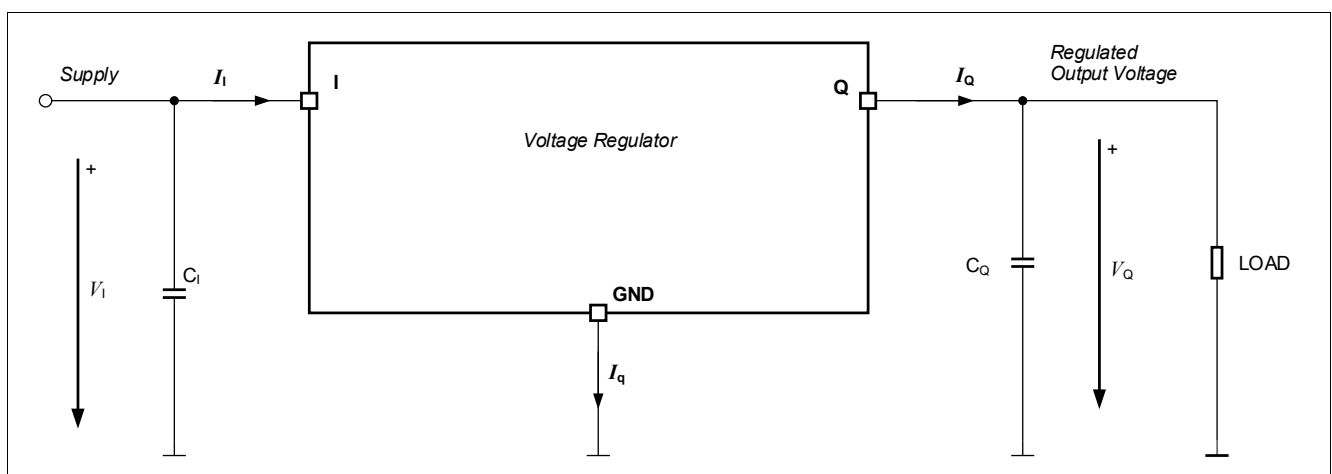

**Figure 5 Parameter definition**

4.2.1 Typical performance characteristics current consumption

Current consumption  $I_q$  versus junction temperature  $T_j$

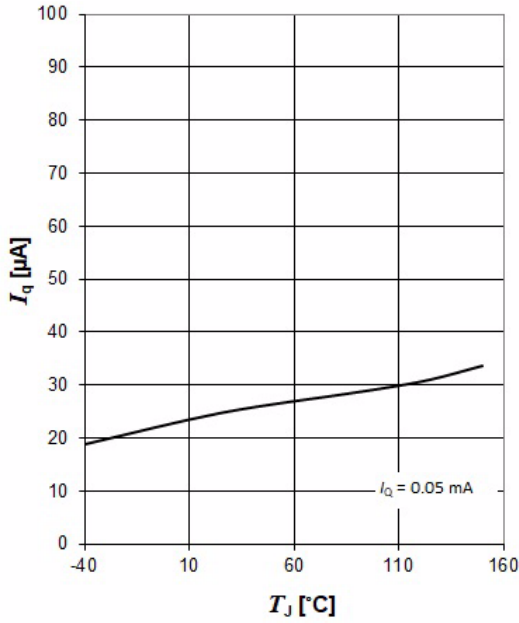

Current consumption  $I_q$  versus output current  $I_Q$

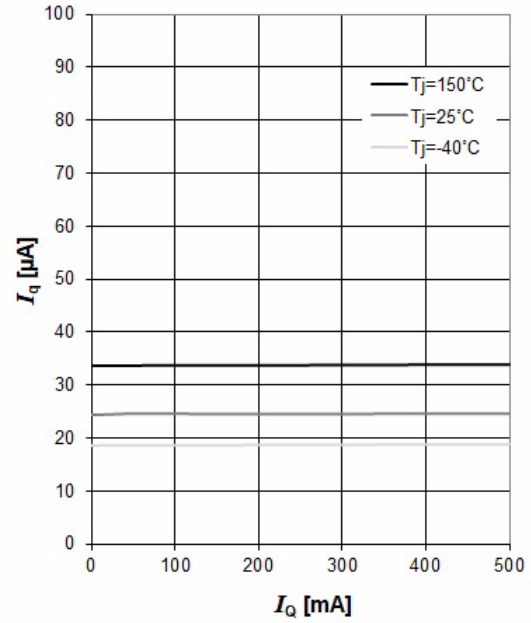

Current consumption  $I_q$  versus input voltage  $V_I$

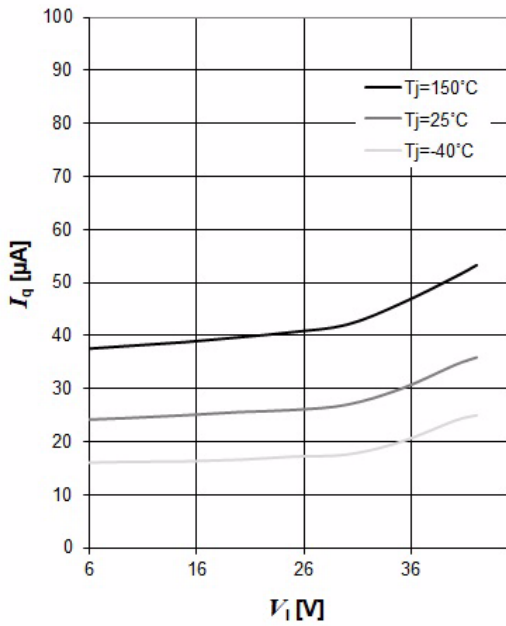



## Block description and electrical characteristics

### 4.3 Reset

The reset function monitors the output voltage  $V_Q$ . It allows a connected system or microcontroller to react to an imminent loss of power. To meet the requirements of the application, some reset related parameters can be adjusted by measures described below.

#### Output undervoltage reset event

If  $V_Q$  drops below the output undervoltage reset lower switching threshold  $V_{RT,low}$ , then the device detects an output undervoltage event and sets the reset output pin RO/WO to “low”. This signal can be used to reset a microcontroller, which is supplied by  $V_Q$ .

#### Reset reaction time

If the output voltage of the regulator drops below the output undervoltage reset lower switching threshold  $V_{RT,low}$ , then the delay capacitor  $C_D$  discharges with the discharge current  $I_{DR,dSCH}$ . As soon as the delay capacitor's voltage  $V_D$  reaches the lower delay switching threshold  $V_{DR,lo}$ , then the device sets the reset output RO/WO to “low”. The time from  $V_Q$  dropping below  $V_{RT,low}$  and the transition of the reset output RO/WO to “low” is the total reset reaction time  $t_{rr,total}$ .

The total reset reaction time  $t_{rr,total}$  is related to the delay capacitor discharge time  $t_{rr,d}$  and the internal reaction time  $t_{rr,int}$ :

$$t_{rr,total} = t_{rr,int} + t_{rr,d} \quad (4.1)$$

with

- $t_{rr,total}$ : Total reset reaction time
- $t_{rr,int}$ : Internal reset reaction time, see [Internal reset reaction time](#)
- $t_{rr,d}$ : Delay capacitor discharge time. For  $C_D = 10$  nF see value specified in [Delay capacitor discharge time](#).

If the output voltage drop lasts shorter than the reset blanking time  $t_{rr,blank}$ , then the delay capacitor does not discharge and the device does not set the reset output RO/WO to “low”. The reset blanking time prevents unintentional microcontroller reset due to very short distortion of the output voltage, see [Timing diagram reset](#).

## Block description and electrical characteristics

### Power-on reset delay time

Before startup of the regulator or after an undervoltage reset event, the delay capacitor  $C_D$  discharges. If the output voltage of the regulator exceeds the output undervoltage reset upper switching threshold  $V_{RT,hi}$ , then this triggers the charging cycle of  $C_D$ .  $C_D$  is charged with the delay capacitor charge current  $I_{D,ch}$ . If  $V_D$  reaches the higher delay switching threshold  $V_{DR,hi}$ , then the device sets the reset output RO/WO to “high”. The time from  $V_Q$  exceeding  $V_{RT,hi}$  until the device sets the reset output RO/WO to “high” is the power-on reset delay time  $t_{d,PWR-ON}$ . The power-on reset delay time allows a microcontroller to start up properly before the reset output RO/WO is released to “high”. The power-on reset delay time  $t_{d,PWR-ON}$  can be configured with the capacitance of the delay capacitor  $C_D$  connected to pin D.

If a power-on reset delay time  $t_{d,PWR-ON}$  different from the value for  $C_D = 10 \text{ nF}$  is required, then the necessary delay capacitor's value can be derived from the specified value given in [Reset delay timing](#) by:

$$C_D = 10 \text{ nF} \times t_{d,PWR-ON} / t_{d,PWR-ON,10nF} \quad (4.2)$$

with

- $t_{d,PWR-ON}$ : Desired power-on reset delay time
- $t_{d,PWR-ON,10nF}$ : Power-on reset delay time, see [Power-on reset delay time](#)
- $C_D$ : Delay capacitor required

The formula is valid for  $C_D \geq 1 \text{ nF}$ . For precise timing calculations also consider the delay capacitor's tolerance.

### Reset output RO/WO

The reset output RO/WO is an open collector output with an integrated pull-up resistor. If a lower-ohmic RO/WO signal is desired, then connect an external pull-up resistor to the output Q. Since the maximum RO/WO sink current is limited, the minimum optional external resistor  $R_{RO/WO,ext}$  is specified in [Reset output, external pull-up resistor to Q](#).

### Reset output RO/WO “low” for $V_Q \geq 1 \text{ V}$

If an undervoltage reset condition occurs, then the device keeps the reset output RO/WO “low” for  $V_Q \geq 1 \text{ V}$ , even if the input voltage  $V_I$  is 0 V. This is achieved by supplying the reset circuit from the output capacitor.

Block description and electrical characteristics

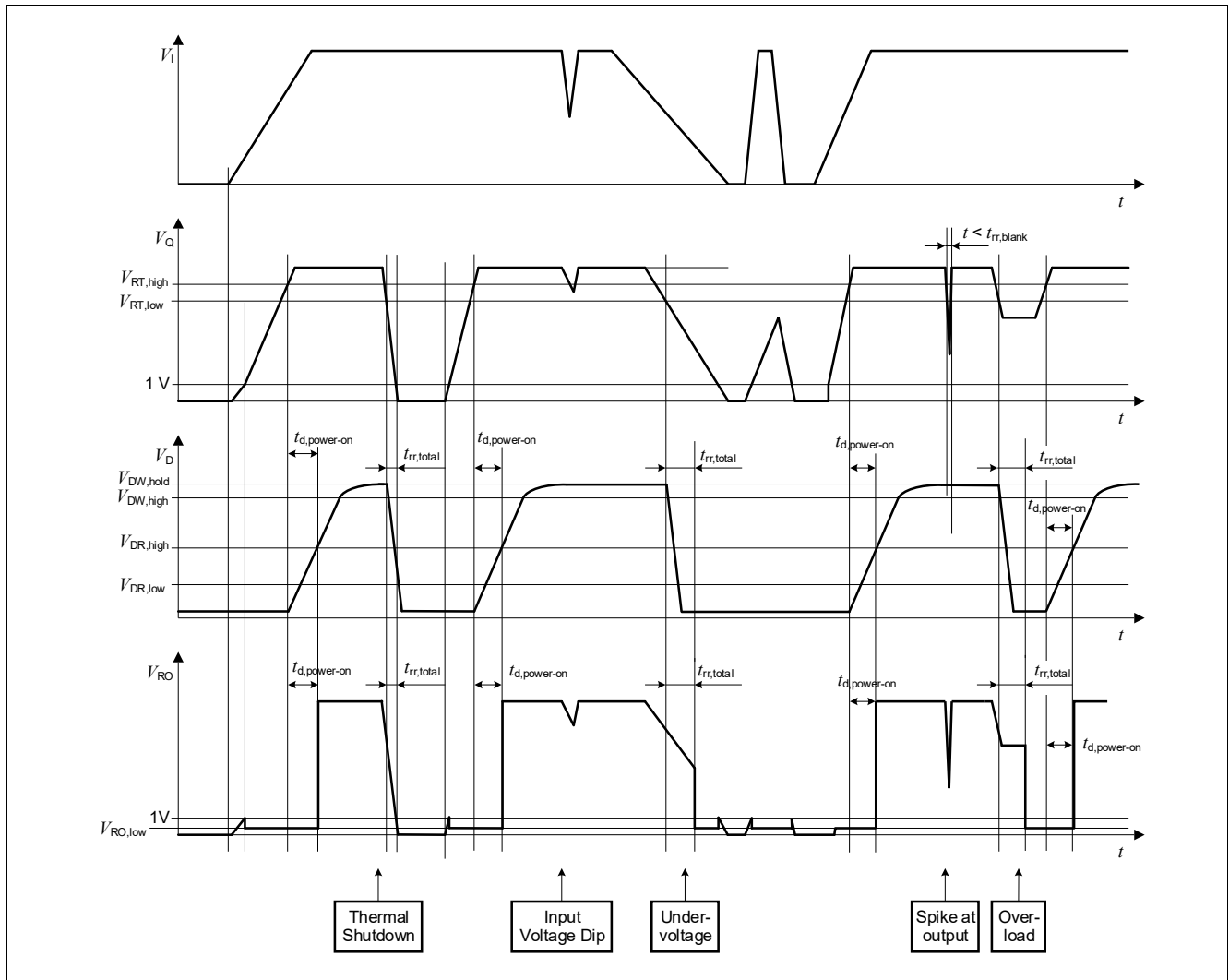

Figure 6 Timing diagram reset

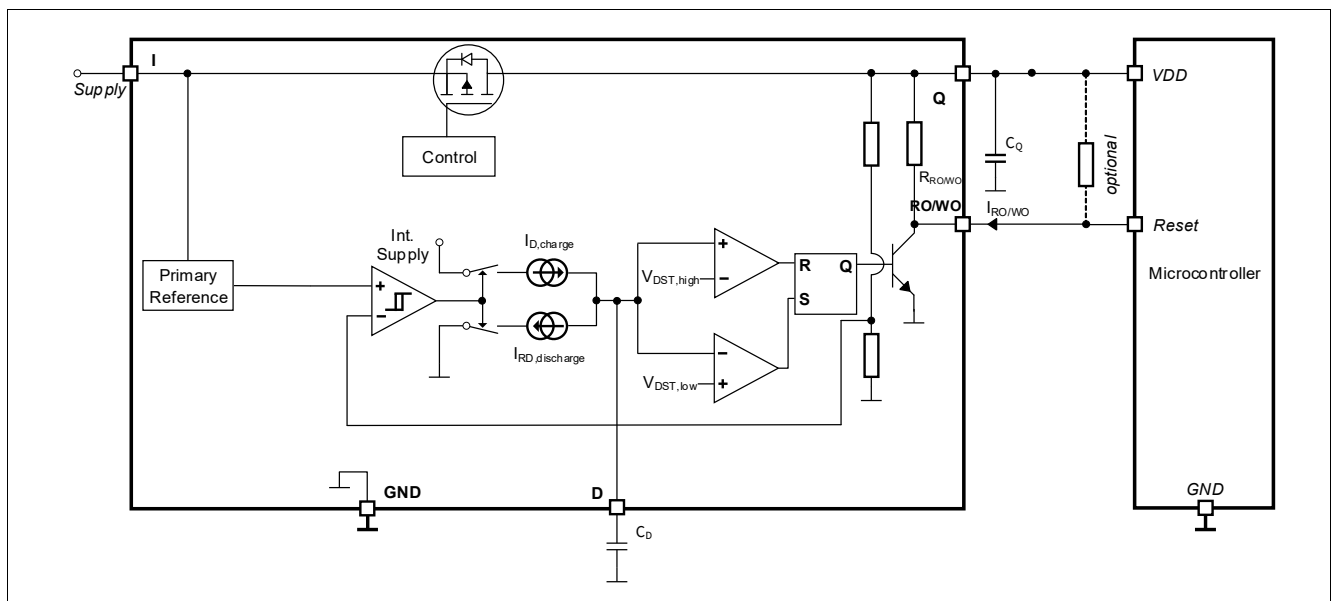

Figure 7 Functional block diagram reset

**Block description and electrical characteristics**

**4.3.1 Electrical characteristics reset**

**Table 6 Electrical characteristics reset**

$V_I = 13.5\text{ V}$ ,  $T_j = -40^\circ\text{C}$  to  $150^\circ\text{C}$ ; all voltages with respect to ground; direction of currents see [Figure 7](#) (unless otherwise specified)

| Parameter  | Symbol              | Values |      |      | Unit          | Note or Test Condition   | Number   |
|--|---------------------|--------|------|------|---------------|--|----------|
|  |                     | Min.   | Typ. | Max. |               |  |          |
| <b>Output undervoltage reset comparator default values</b> |                     |        |      |      |               |  |          |
| Output undervoltage reset lower switching threshold        | $V_{RT,low}$        | 4.5    | 4.6  | 4.75 | V             | $V_Q$ decreasing;<br>$V_{RT,low} \leq V_I \leq 42\text{ V}$                          | P_4.4.3  |
| Output undervoltage reset upper switching threshold        | $V_{RT,high}$       | 4.6    | 4.7  | 4.85 | V             | $V_Q$ increasing;<br>$V_{RT,high} \leq V_I \leq 42\text{ V}$                         | P_4.4.4  |
| Output undervoltage reset switching hysteresis             | $V_{RT,hy}$         | 30     | 100  | 200  | mV            | $V_I$ within operating range   | P_4.4.10 |
| <b>Reset output RO/WO</b>                                  |                     |        |      |      |               |  |          |
| Reset output “low” voltage                                 | $V_{RO/WO,low}$     | –      | 0.2  | 0.4  | V             | $1\text{ V} \leq V_Q \leq V_{RT}$ ;<br>$R_{RO,ext} \geq 6.2\text{ k}\Omega$          | P_4.4.16 |
| Reset output, external pull-up resistor to Q               | $R_{RO/WO,ext}$     | 6.2    | –    | –    | k $\Omega$    | $1\text{ V} \leq V_Q \leq V_{RT}$ ;<br>$V_{RO} \leq 0.4\text{ V}$                    | P_4.4.17 |
| Reset output, internal pull-up resistor                    | $R_{RO/WO,int}$     | 10     | 20   | 35   | k $\Omega$    | Internally connected to Q  | P_4.4.18 |
| <b>Reset delay timing</b>                                  |                     |        |      |      |               |  |          |
| Lower delay switching threshold                            | $V_{DR,low}$        | –      | 0.6  | –    | V             | –  | P_4.4.20 |
| Delay capacitor charge current                             | $I_{D,ch}$          | –      | 1.6  | –    | $\mu\text{A}$ | $V_D = 1.2\text{ V}$   | P_4.4.21 |
| Delay capacitor reset discharge current                    | $I_{DR,dsch}$       | –      | 180  | –    | mA            | $V_D = 1.2\text{ V}$   | P_4.4.22 |
| Power-on reset delay time                                  | $t_{d,PWR-ON,10nF}$ | 3      | 6    | 9    | ms            | <sup>1)</sup> Calculated value;<br>$C_D = 10\text{ nF}$ ;<br>$C_D$ discharged to 0 V | P_4.4.23 |
| Internal reset reaction time                               | $t_{rr,int}$        | 3      | 8    | 40   | $\mu\text{s}$ | $C_D = 0\text{ nF}$ , $V_Q = 4\text{ V}$ ;<br>$V_{WINH,high} \leq V_{WINH}$          | P_4.4.24 |
| Delay capacitor discharge time                             | $t_{rr,d,10nF}$     | –      | 0.2  | 0.3  | $\mu\text{s}$ | <sup>1)</sup> $C_D = 10\text{ nF}$   | P_4.4.26 |
| Total reset reaction time                                  | $t_{rr,total,10nF}$ | –      | 10   | 41   | $\mu\text{s}$ | Calculated value:<br>$t_{rr,d,10nF} + t_{rr,int}$ ;<br>$C_D = 10\text{ nF}$          | P_4.4.27 |
| Reset blanking time  | $t_{rr,blank}$      | –      | 3    | –    | $\mu\text{s}$ | <sup>2)</sup>  | P_4.4.28 |

1) For programming a different delay and reset reaction time, see [Reset](#).

2) Not subject to production test, specified by design.

### 4.3.2 Typical performance characteristics reset

Undervoltage reset lower switching threshold  $V_{RT,lo}$  versus junction temperature  $T_j$

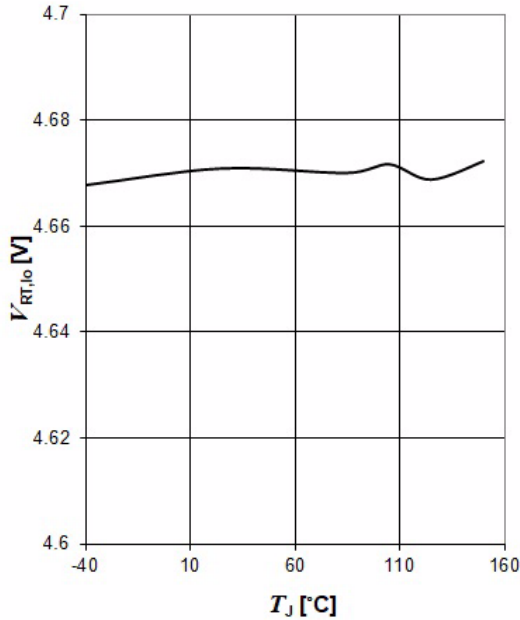

Power-on reset delay time  $t_{d,PWR-ON}$  versus delay capacitance  $C_D$

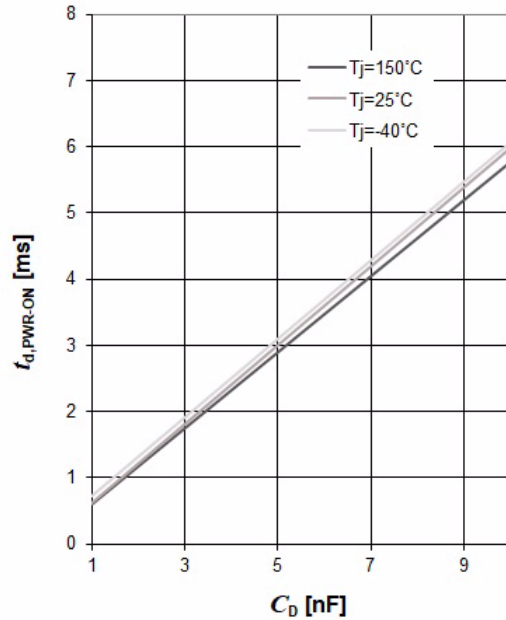

Power-on reset delay time  $t_{d,PWR-ON}$  versus junction temperature  $T_j$

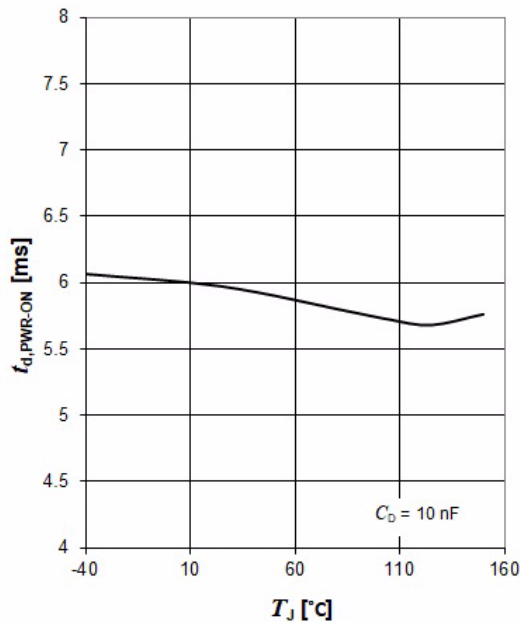

Internal reset reaction time  $t_{rr,int}$  versus junction temperature  $T_j$

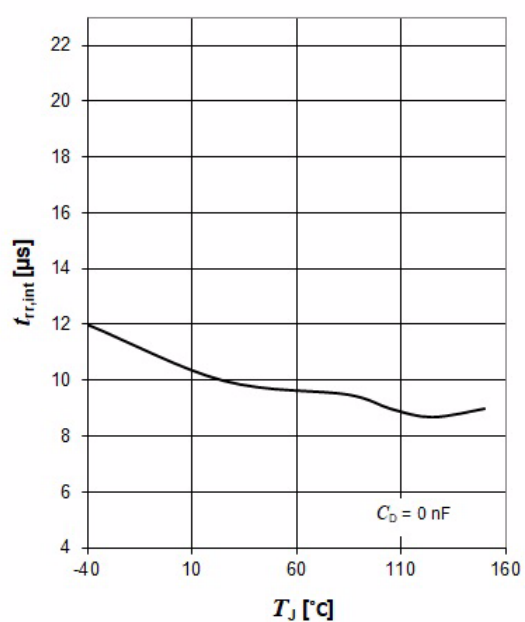

**Block description and electrical characteristics**

**Total reset reaction time  $t_{rr,total}$  versus  
junction temperature  $T_j$**

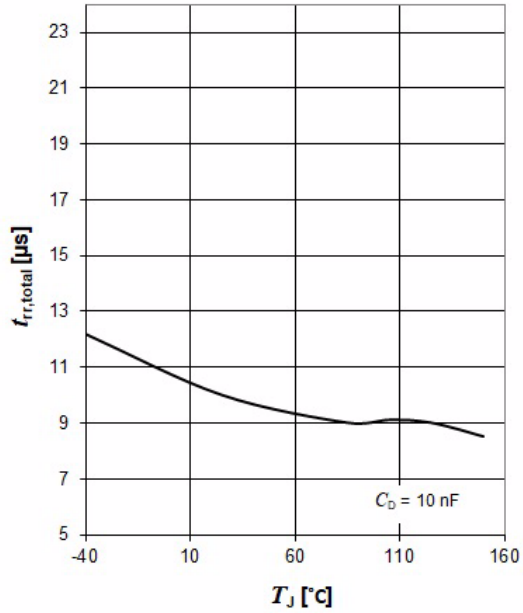

**Block description and electrical characteristics**

**4.4 Watchdog**

The device offers a watchdog with inhibit feature and programmable watchdog timing. The watchdog function monitors a microcontroller to detect time based failures. If the device detects a missing rising edge at the WI pin, then it sets the watchdog output to “low” after a defined time. An external delay capacitor  $C_D$  is used to configure the timing. For details on how the WI signal can comply with watchdog timing, see [Timing diagram watchdog](#).

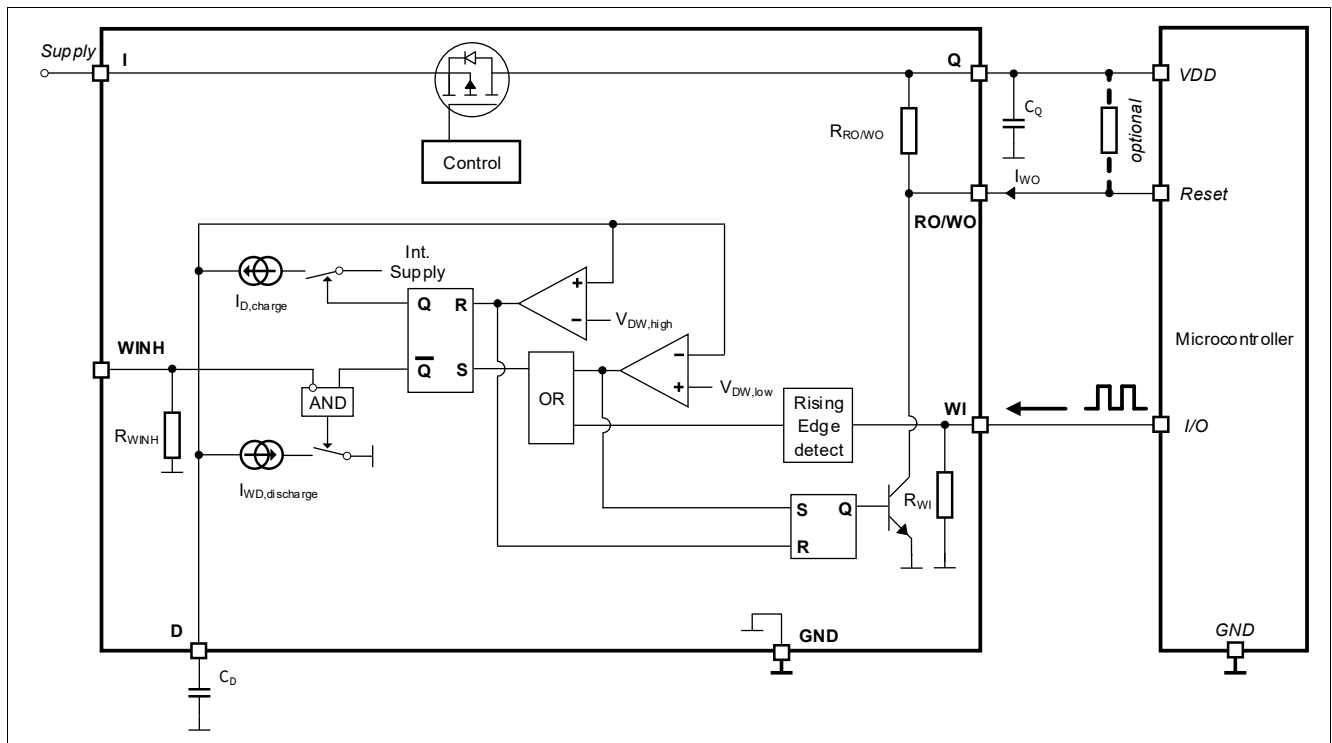

**Figure 8 Functional block diagram watchdog circuit**

**Watchdog inhibit input WINH**

The watchdog inhibit input WINH enables or disables the watchdog function. A “high” signal at WINH disables the watchdog. When disabled, the capacitor at the D pin is charged to the watchdog deactivation hold voltage  $V_{DW,hold}$ . The signal applied to WINH must comply with the values in [Watchdog inhibit WINH](#).

**Watchdog output RO/WO**

The watchdog output RO/WO is an open collector output with an integrated pull-up resistor. If a lower-ohmic RO/WO signal is desired, then connect an external pull-up resistor to the output Q. Since the maximum RO/WO sink current is limited, the minimum external resistor value  $R_{RO/WO,ext}$  is specified in [Watchdog output external pull-up resistor](#).

**Block description and electrical characteristics**

**Watchdog input WI**

A positive edge at the watchdog input WI triggers the watchdog. Because of the integrated high pass filter, the amplitude and slope of the signal at WI pin must comply with the values in **Watchdog input WI**. For details on the test pulse applied, see **Figure 9**.

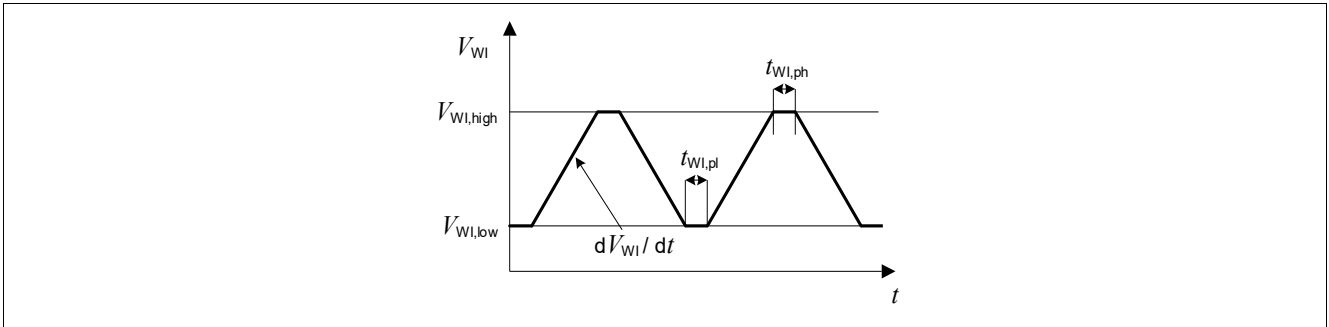

**Figure 9 Test pulses watchdog input WI**

**Watchdog timing**

If the watchdog is enabled and the device does not detect a rising edge at the WI pin, then the delay capacitor  $C_D$  is continuously charged and discharged between  $V_{DW,low}$  and  $V_{DW,high}$ , see **Functional block diagram watchdog circuit**. The RO/WO pin goes “low” for  $t_{WD,lo}$  when the delay capacitor voltage  $V_D$  discharges to  $V_{DW,low}$ . Due to the cyclic nature of this behavior, this pattern repeats with the watchdog period  $t_{WD,p}$ .

If the device detects a rising edge at the WI pin during the  $C_D$  discharge cycle, then a new charge cycle starts. To prevent the device from setting RO/WO to “low”, a rising edge on the WI pin must occur within the watchdog trigger time  $t_{WI,tr}$ . For timing details see **Timing diagram watchdog**.

If a watchdog trigger time  $t_{WI,tr}$  different from the one for  $C_D = 10$  nF is required, then the delay capacitor’s value can be derived from the value in **Watchdog timing** by:

$$C_D = 10 \text{ nF} \times t_{WI,tr} / t_{WI,tr,10nF} \tag{4.3}$$

The watchdog output “low” time  $t_{WD,lo}$  and the watchdog period  $t_{WD,p}$  equate to:

$$t_{WD,lo} = t_{WD,lo,10nF} \times C_D / 10 \text{ nF} \tag{4.4}$$

$$t_{WD,p} = t_{WI,tr} + t_{WD,lo} \tag{4.5}$$

The formula applies for  $C_D \geq 1$  nF. For precise timing calculations consider the delay capacitor’s tolerance.



**Block description and electrical characteristics**

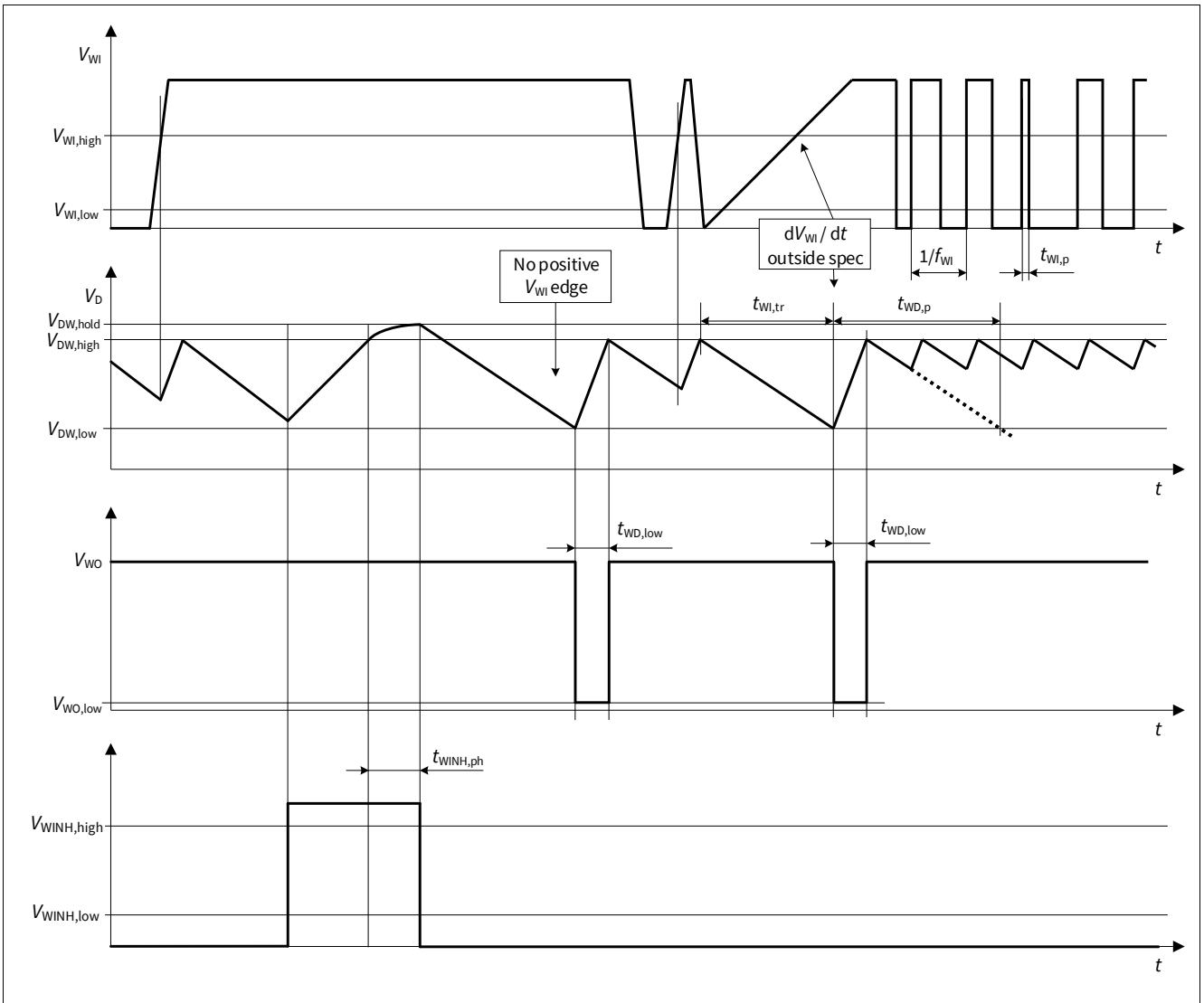

**Figure 10 Timing diagram watchdog**

**Block description and electrical characteristics**

**4.4.1 Electrical characteristics watchdog**

**Table 7 Electrical characteristics watchdog**

$V_I = 13.5\text{ V}$ ,  $T_j = -40^\circ\text{C}$  to  $150^\circ\text{C}$ ; all voltages with respect to ground, direction of currents see [Figure 8](#) (unless otherwise specified)

| Parameter                                    | Symbol                          | Values |      |      | Unit                   | Note or Test Condition   | Number   |
|--|---------------------------------|--------|------|------|------------------------|--|----------|
|  |                                 | Min.   | Typ. | Max. |                        |  |          |
| <b>Watchdog inhibit WINH</b>                 |                                 |        |      |      |                        |  |          |
| Watchdog inhibit “low” signal valid          | $V_{\text{WINH,low}}$           | –      | –    | 0.8  | V                      | –  | P_4.5.1  |
| Watchdog inhibit “high” signal valid         | $V_{\text{WINH,high}}$          | 2      | –    | –    | V                      | –  | P_4.5.2  |
| Watchdog inhibit “high” level input current  | $I_{\text{WINH,high}}$          | –      | –    | 4    | $\mu\text{A}$          | $V_{\text{WINH}} = 3.3\text{ V}$   | P_4.5.3  |
| Watchdog inhibit “high” signal pulse length  | $t_{\text{WINH,ph}}$            | –      | 2.5  | –    | ms                     | $C_D = 10\text{ nF}$ ;<br>$V_{\text{WINH}} \geq V_{\text{WINH,high}}$        | P_4.5.5  |
| Watchdog inhibit internal pull-down resistor | $R_{\text{WINH}}$               | 0.825  | 1.5  | 2.6  | $\text{M}\Omega$       | –  | P_4.5.6  |
| <b>Watchdog input WI</b>                     |                                 |        |      |      |                        |  |          |
| Watchdog input “low” signal valid            | $V_{\text{WI,low}}$             | –      | –    | 0.8  | V                      | <sup>1)</sup>  | P_4.5.7  |
| Watchdog input “high” signal valid           | $V_{\text{WI,high}}$            | 2      | –    | –    | V                      | <sup>1)</sup>  | P_4.5.8  |
| Watchdog input “low” signal pulse length     | $t_{\text{WI,pl}}$              | 1      | –    | –    | $\mu\text{s}$          | <sup>1)</sup> $V_{\text{WI}} \leq V_{\text{WI,low}}$                         | P_4.5.9  |
| Watchdog input “high” signal pulse length    | $t_{\text{WI,ph}}$              | 1      | –    | –    | $\mu\text{s}$          | <sup>1)</sup> $V_{\text{WI}} \geq V_{\text{WI,high}}$                        | P_4.5.10 |
| Watchdog input “high” level input current    | $I_{\text{WI,H}}$               | –      | –    | 4    | $\mu\text{A}$          | $V_{\text{WI}} = 3.3\text{ V}$   | P_4.5.11 |
| Watchdog input signal slew rate              | $\Delta V_{\text{WI}}/\Delta t$ | 1      | –    | –    | $\text{V}/\mu\text{s}$ | <sup>1)</sup> $V_{\text{WI,low}} \leq V_{\text{WI}} \leq V_{\text{WI,high}}$ | P_4.5.12 |
| Watchdog input internal pull-down resistor   | $R_{\text{WI}}$                 | 0.825  | 1.5  | 2.6  | $\text{M}\Omega$       | –  | P_4.5.13 |
| <b>Watchdog output WO</b>                    |                                 |        |      |      |                        |  |          |
| Watchdog output “low” voltage                | $V_{\text{WO,low}}$             | –      | 0.2  | 0.4  | V                      | $V_Q \geq 2.5\text{ V}$ ;<br>$R_{\text{WO}} \geq 6.2\text{ k}\Omega$         | P_4.5.14 |
| Watchdog output external pull-up resistor    | $R_{\text{WO,ext}}$             | 6.2    | –    | –    | $\text{k}\Omega$       | $V_Q \geq 2.5\text{ V}$ ;<br>$V_{\text{WO}} \leq 0.4\text{ V}$               | P_4.5.15 |
| Watchdog output internal pull-up resistor    | $R_{\text{WO,int}}$             | 10     | 20   | 35   | $\text{k}\Omega$       | –  | P_4.5.16 |
| <b>Watchdog timing</b>                       |                                 |        |      |      |                        |  |          |
| Delay capacitor charge current               | $I_D$                           | –      | 1.6  | –    | $\mu\text{A}$          | $V_D = 1.2\text{ V}$   | P_4.5.17 |

**Block description and electrical characteristics**

**Table 7 Electrical characteristics watchdog** (cont'd)

$V_I = 13.5\text{ V}$ ,  $T_j = -40^\circ\text{C}$  to  $150^\circ\text{C}$ ; all voltages with respect to ground, direction of currents see [Figure 8](#) (unless otherwise specified)

| Parameter                                     | Symbol            | Values |      |      | Unit          | Note or Test Condition   | Number   |
|---|-------------------|--------|------|------|---------------|--|----------|
|   |                   | Min.   | Typ. | Max. |               |  |          |
| Delay capacitor deactivation charge current   | $I_{DW,ch,deact}$ | –      | 1.6  | –    | $\mu\text{A}$ | $V_D = 1.2\text{ V}$   | P_4.5.18 |
| Delay capacitor watchdog discharge current    | $I_{DW,disch}$    | –      | 0.5  | –    | $\mu\text{A}$ | $V_D = 1.2\text{ V}$   | P_4.5.19 |
| Upper watchdog timing threshold               | $V_{DW,high}$     | –      | 1.45 | –    | V             | –  | P_4.5.20 |
| Lower watchdog timing threshold               | $V_{DW,low}$      | –      | 0.9  | –    | V             | –  | P_4.5.21 |
| Upper delay watchdog deactivated hold voltage | $V_{DW,deact}$    | –      | 1.5  | –    | V             | $V_{WINH} \geq V_{WINH,high}$  | P_4.5.22 |
| Watchdog trigger time                         | $t_{WI,tr,10nF}$  | 3.5    | 13   | 21   | ms            | <sup>2)</sup> Calculated value;<br>$C_D = 10\text{ nF}$  | P_4.5.23 |
| Watchdog output “low” time                    | $t_{WD,lo,10nF}$  | 1.5    | 4    | 6    | ms            | <sup>2)</sup> Calculated value;<br>$C_D = 10\text{ nF}$  | P_4.5.24 |
| Watchdog period                               | $t_{WD,p,10nF}$   | 5      | 17   | 27   | ms            | <sup>2)</sup> Calculated value;<br>$t_{WI,tr,10nF} + t_{WD,lo,10nF}$ ;<br>$C_D = 10\text{ nF}$ | P_4.5.25 |

1) For details on the test pulse applied, see [Figure 9](#).

2) For programming the watchdog timing, see [Watchdog](#).

4.4.2 Typical performance characteristics watchdog

Watchdog trigger time  $t_{WI,tr}$  versus delay capacitance  $C_D$

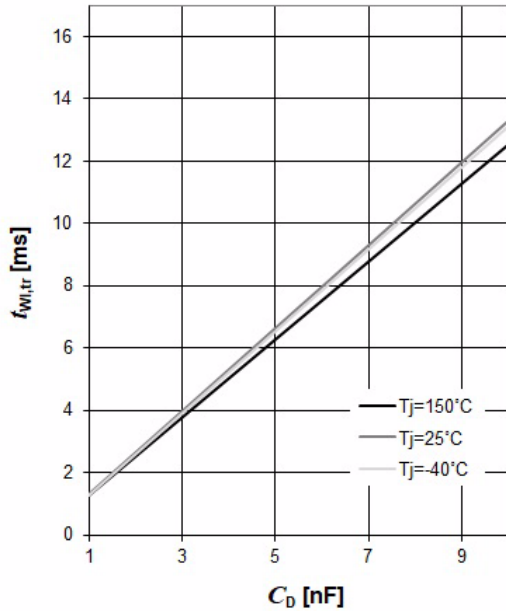

Watchdog trigger time  $t_{WI,tr}$  versus junction temperature  $T_j$

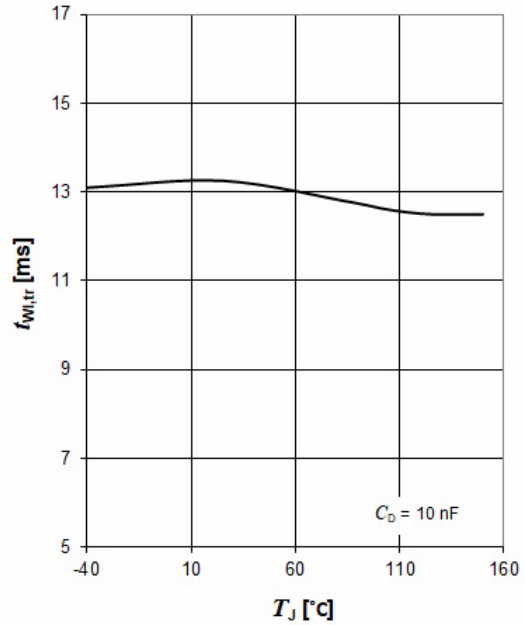

Watchdog inhibit high signal pulse length  $t_{WINH,ph}$  versus junction temperature  $T_j$

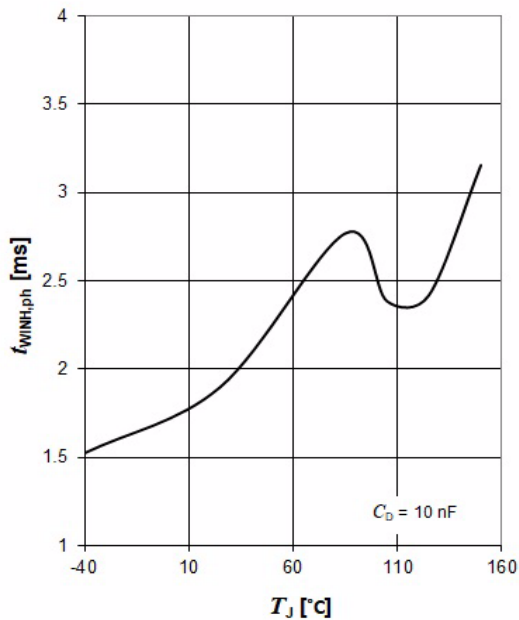

Watchdog output “low” time  $t_{WD,lo}$  versus junction temperature  $T_j$

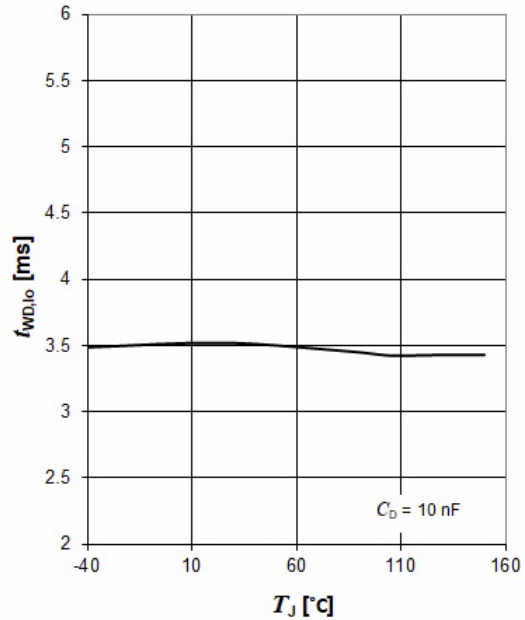

**Block description and electrical characteristics**

**Watchdog output “low” time  $t_{WD,lo}$  versus delay capacitance  $C_D$**

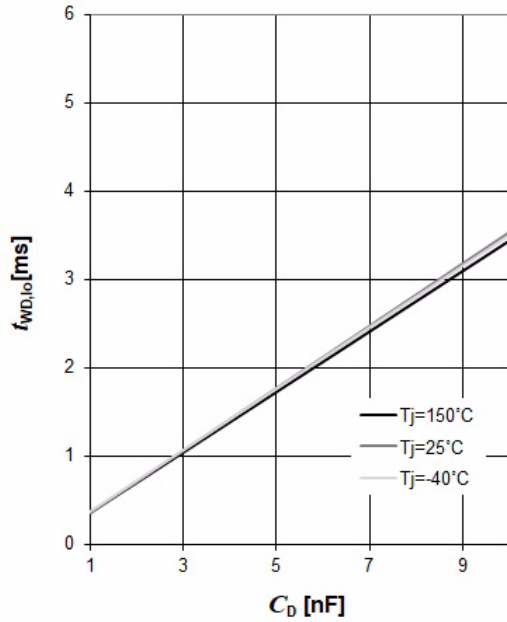

**Application information**

**5 Application information**

*Note: The following information is given as a hint for the implementation of the device only and shall not be regarded as a description or warranty of a certain functionality, condition or quality of the device.*

**5.1 Application diagram**

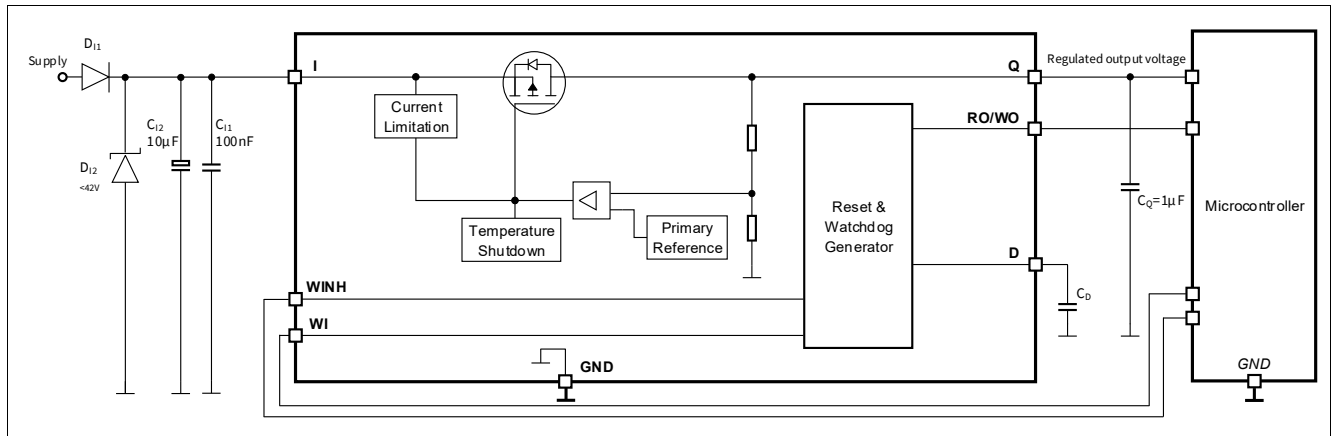

**Figure 11 Application diagram**

**5.2 Selection of external components**

**5.2.1 Input pin**

**Figure 11** shows the typical input circuitry for a linear voltage regulator. A ceramic capacitor at the input, in the range of 100 nF to 470 nF, is recommended to filter out high frequency disturbances imposed by the line, such as ISO pulses 3a/b. The capacitor must be placed very close to the input pin of the linear voltage regulator on the PCB.

An aluminum electrolytic capacitor in the range of 10 μF to 470 μF is recommended as an input buffer to smooth out high energy pulses, such as ISO pulse 2a. This capacitor should be placed close to the input pin of the linear voltage regulator on the PCB.

An overvoltage suppressor diode can be used to further suppress any voltage exceeding the maximum rating of the linear voltage regulator and protect the device against damage due to overvoltage.

The external components at the input are not mandatory for the operation of the voltage regulator, but they are recommended in case of possible external disturbances.

**5.2.2 Output pin**

An output capacitor is mandatory for the stability of a linear voltage regulator. The requirement to the output capacitor is given in **Functional range**.

The device is designed to be stable with extremely low ESR capacitors. According to automotive requirements, ceramic capacitors with X5R or X7R dielectrics are recommended.

The output capacitor should be placed as close as possible to the regulator’s output and to GND pins and on the same side of the PCB as the regulator itself.

## Application information

In case of rapid transients of input voltage or load current, the capacitance should be dimensioned in accordance and verified in the real application to fulfill the output stability requirements.

### 5.3 Thermal considerations

Knowing the input voltage, the output voltage and the load profile of the application, the total power dissipation can be calculated:

$$P_D = (V_I - V_Q) \times I_Q + V_I \times I_q \quad (5.1)$$

with

- $P_D$ : continuous power dissipation
- $V_I$ : input voltage
- $V_Q$ : output voltage
- $I_Q$ : output current
- $I_q$ : quiescent current

The maximum acceptable thermal resistance  $R_{thJA}$  can then be calculated:

$$R_{thJA,max} = (T_{j,max} - T_a) / P_D \quad (5.2)$$

with

- $T_{j,max}$ : maximum allowed junction temperature
- $T_a$ : ambient temperature

Based on the above calculation the proper PCB type and the necessary heat sink area can be determined with reference to the specification in [Thermal resistance](#).

#### Example

Application conditions:

$$V_I = 13.5 \text{ V}$$

$$V_Q = 5 \text{ V}$$

$$I_Q = 50 \text{ mA}$$

$$T_a = 85^\circ\text{C}$$

Calculation of  $R_{thJA,max}$ :

$$P_D = (V_I - V_Q) \times I_Q + V_I \times I_q$$

$$= (13.5 \text{ V} - 5 \text{ V}) \times 50 \text{ mA} + 13.5 \text{ V} \times 33 \mu\text{A}$$

$$= 0.425 \text{ W} + 0.000446 \text{ W}$$

$$= 0.425446 \text{ W}$$

$$R_{thJA,max} = (T_{j,max} - T_a) / P_D$$

$$= (150^\circ\text{C} - 85^\circ\text{C}) / 0.425446 \text{ W} = 152.781 \text{ K/W}$$

As a result, the PCB design must ensure a thermal resistance  $R_{thJA}$  lower than 152.781 K/W. According to [Thermal resistance](#), at least 300 mm<sup>2</sup> heatsink area is needed on the FR4 1s0p PCB, or the FR4 2s2p board can be used.

### 5.4 Reverse polarity protection

The device must be protected from reverse polarity by external components. An external reverse polarity diode is required. The [Absolute maximum ratings](#) of the device must be maintained.

**Application information**

**5.5 Further application information**

- Please contact Infineon for information on pin behavior assessment
- Existing application note
- For further information you may contact <https://www.infineon.com>





**Revision history**

## **7 Revision history**

| <b>Revision</b> | <b>Date</b> | <b>Changes</b>    |
|-----------------|-------------|-------------------|
| 1.1             | 2023-10-16  | Editorial changes |
| 1.0             | 2022-11-29  | Datasheet created |

## Trademarks

All referenced product or service names and trademarks are the property of their respective owners.

**Edition 2023-10-16**

**Published by**

**Infineon Technologies AG**

**81726 Munich, Germany**

**© 2023 Infineon Technologies AG.**

**All Rights Reserved.**

**Do you have a question about any aspect of this document?**

**Email: [erratum@infineon.com](mailto:erratum@infineon.com)**

**Document reference**

**Z8F70660207**

## IMPORTANT NOTICE

The information given in this document shall in no event be regarded as a guarantee of conditions or characteristics ("Beschaffheitsgarantie").

With respect to any examples, hints or any typical values stated herein and/or any information regarding the application of the product, Infineon Technologies hereby disclaims any and all warranties and liabilities of any kind, including without limitation warranties of non-infringement of intellectual property rights of any third party.

In addition, any information given in this document is subject to customer's compliance with its obligations stated in this document and any applicable legal requirements, norms and standards concerning customer's products and any use of the product of Infineon Technologies in customer's applications.

The data contained in this document is exclusively intended for technically trained staff. It is the responsibility of customer's technical departments to evaluate the suitability of the product for the intended application and the completeness of the product information given in this document with respect to such application.

For further information on technology, delivery terms and conditions and prices, please contact the nearest Infineon Technologies Office ([www.infineon.com](http://www.infineon.com)).

## WARNINGS

Due to technical requirements products may contain dangerous substances. For information on the types in question please contact your nearest Infineon Technologies office.

Except as otherwise explicitly approved by Infineon Technologies in a written document signed by authorized representatives of Infineon Technologies, Infineon Technologies' products may not be used in any applications where a failure of the product or any consequences of the use thereof can reasonably be expected to result in personal injury.