

FEATURES

- Basic/supplementary isolation to UL60950²
- ANSI/AAMI ES60601-1
- Single and dual outputs
- UL 94V-0 package material
- SIP package style
- 5.2kVDC isolation 'Hi Pot Test'
- 3.3V, 5V, 12V, 15V & 24V inputs
- 3.3V, 5V, 9V, 12V & 15V outputs
- Internal SMD construction
- Fully encapsulated with toroidal magnetics
- Pin compatible with the MEV, NMV, NMK, MEJ2 & NMJ series
- Characterised CMTI >200kV/μS
- Continuous barrier withstand voltage 2.4kVDC

PRODUCT OVERVIEW

The MEJ1 series are single and dual output DC-DC converters in a 7 pin SIP package style offering an isolation and insulation upgrade path from the NMV & MEV1 series¹. The MEJ1 series has UL60950 and ANSI/AAMI ES60601-1 recognition, which makes it ideal for applications where safety and miniaturisation are of paramount importance.

SELECTION GUIDE

Order Code	Nominal Input Voltage	Output Voltage	Output Current	Input Current (Typ)	Load Regulation (Typ)	Load Regulation (Max)	Ripple & Noise (Typ) ³	Ripple & Noise (Max) ³	Efficiency (Min)	Efficiency (Typ)	MTTF ¹	Recommended Alternative	
	V	V	mA		%	%	mVp-p	mVp-p	%	%	kHrs		
Recommended In Production													
Single	MEJ1S0303SC	3.3	3.3	303	410	8.5	11	42	55	67	70	3653	
	MEJ1S0305SC	3.3	5	200	400	9	10	33	45	68	71.5	3810	
	MEJ1S0503SC	5	3.3	303	280	6.5	8	20	40	66	69	4117	
	MEJ1S0505SC	5	5	200	270	5.5	7	24	40	68	72	4082	
	MEJ1S0509SC	5	9	111	265	4.5	5	20	40	70	74	3939	
	MEJ1S0512SC	5	12	83	260	4.5	7	22	40	71	74	3816	
	MEJ1S0515SC	5	15	66	260	5	6	22	40	72	75	3412	
	MEJ1S1203SC	12	3.3	303	110	6	7	25	45	69	72	3461	
	MEJ1S1205SC	12	5	200	110	5	6	21	40	71	74.5	3319	
	MEJ1S1209SC	12	9	111	105	4	5	18	40	73	76.5	3218	
	MEJ1S1212SC	12	12	83	105	3.5	5	19	40	73	76.5	3494	
	MEJ1S1215SC	12	15	66	105	4	5	16	40	73	77	3150	
	MEJ1S1505SC	15	5	200	90	5	6	23	45	70	74	3048	
	MEJ1S1509SC	15	9	111	85	4	5	18	40	72	76	2963	
	MEJ1S1512SC	15	12	83	85	4	5	20	40	72	76.5	2733	
	MEJ1S1515SC	15	15	66	85	4	5	19	35	73	76.5	2333	
	MEJ1S2405SC	24	5	200	55	5	6	23	40	71	75	3353	
	MEJ1S2409SC	24	9	111	55	4	7	17	40	72	77	2940	
MEJ1S2412SC	24	12	83	55	4	5	19	40	72	78	2987		
MEJ1S2415SC	24	15	66	55	3.5	5	17	40	74	78	2517		
Dual	MEJ1D0503SC	5	±3.3	±151	280	6	8	19	40	67	70	4511	
	MEJ1D0505SC	5	±5	±100	275	5	6	23	35	69	72	4012	
	MEJ1D0509SC	5	±9	±55	265	4	6	16	35	69	74	3492	
	MEJ1D0512SC	5	±12	±42	260	4	5	15	30	72	74.5	3485	
	MEJ1D1209SC	12	±9	±55	110	4	5	15	35	73	77	2908	
	MEJ1D1212SC	12	±12	±42	110	3.5	5	14	30	74	76.5	2911	
	MEJ1D1515SC	15	±15	±33	85	3.5	5	20	35	73	76.5	2440	
	MEJ1D2409SC	24	±9	±55	55	3.5	5	17	35	73	78	3208	
	MEJ1D2415SC	24	±15	±33	55	3.5	5	14	35	74	78.5	2697	
	Discontinued												
Dual	MEJ1D0515SC	5	±15	±33	260	4	5	13	35	71	75.5	2844	NMJ0515SC
	MEJ1D1203SC	12	±3.3	±151	110	5.5	6	19	40	70	73	3461	MEJ1S1203SC
	MEJ1D1205SC	12	±5	±100	110	4.5	5	18	40	72	75.5	3317	NMJ1205SC
	MEJ1D1215SC	12	±15	±33	110	4	5	11	35	73	77	2713	NMJ1215SC
	MEJ1D1505SC	15	±5	±100	90	4.5	5	19	40	72	75	3274	MEJ2D1505SC
	MEJ1D1509SC	15	±9	±55	85	4	5	14	35	73	76.5	3229	MEJ2D1509SC
	MEJ1D1512SC	15	±12	±42	85	3.5	5	13	35	73	77	2872	MEJ1S1512SC
	MEJ1D2405SC	24	±5	±100	55	4.5	5	19	40	72	76.5	3316	MEJ1S2405SC
MEJ1D2412SC	24	±12	±42	55	3.5	5	12	35	74	78	3362	MEJ1S2412SC	



For full details go to
<https://www.murata.com/en-global/products/power/rohs>



1. Calculated using MIL-HDBK-217 FN2 calculation model with nominal input voltage at full load.
 2. See safety approvals section for limitations of use.
 3. See ripple & noise test method.
 All specifications typical at T_A=25°C, nominal input voltage and rated output current unless otherwise specified.

INPUT CHARACTERISTICS					
Parameter	Conditions	Min.	Typ.	Max.	Units
Voltage range	Continuous operation, 3V input types	2.97	3.3	3.63	V
	Continuous operation, 5V input types	4.5	5	5.5	
	Continuous operation, 12V input types	10.8	12	13.2	
	Continuous operation, 15V input types	13.5	15	16.5	
	Continuous operation, 24V input types	21.6	24	26.4	
Input reflected ripple	3.3V input types		40		mA
	5V input types		24		
	12V & 15V input types		12		
	24V input types		8		

OUTPUT CHARACTERISTICS					
Parameter	Conditions	Min.	Typ.	Max.	Units
Rated Power ²	T _A =-40°C to 85°C			1	W
Voltage Set Point Accuracy	See tolerance envelopes				
Line regulation	High V _{IN} to low V _{IN}		1.1	1.2	%/%

ISOLATION CHARACTERISTICS					
Parameter	Conditions	Min.	Typ.	Max.	Units
Isolation test voltage	Production tested for 1 second	5200			VDC
	Qualification tested for 1 second	7000			
	Qualification tested for 1 minute	5200			
Resistance	Viso= 500VDC		1		GΩ
Isolation capacitance			3		pF
Continuous barrier withstand voltage	Non-safety barrier application			2400	V
Safety standard	UL60950-1			200	Vrms
	ANSI/AAMI ES60601-1	1 M00P		200	

GENERAL CHARACTERISTICS					
Parameter	Conditions	Min.	Typ.	Max.	Units
Switching frequency	All types		50		kHz

TEMPERATURE CHARACTERISTICS					
Parameter	Conditions	Min.	Typ.	Max.	Units
Specification	All output types, (see safety approval section for limitations)	-40		85	°C
Storage		-55		125	
Case Temperature above ambient	MEJ1S1212SC, MEJ1S1512SC, MEJ1S2412SC, MEJ1D1215SC, MEJ1D1512SC, MEJ1D2412SC, MEJ1D2415SC, MEJ1S1215SC, MEJ1S1509SC, MEJ1S2409SC		13		
	MEJ1D1205SC, MEJ1D1209SC, MEJ1D2405SC, MEJ1D2409SC, MEJ1S1209SC, MEJ1S1515SC, MEJ1S2415SC, MEJ1D1212SC, MEJ1D1509SC, MEJ1S0515SC, MEJ1S2405SC, MEJ1D0512SC, MEJ1D0515SC, MEJ1D1515SC, MEJ1S1505SC, MEJ1D0505SC, MEJ1D0509SC, MEJ1D1203SC, MEJ1D1505SC, MEJ1S0509SC, MEJ1S0512SC, MEJ1S1205SC		17		
	MEJ1S0505SC, MEJ1S1203SC, MEJ1D0503SC, MEJ1S0303SC, MEJ1S0305SC, MEJ1S0503SC		21		
Cooling	Free air convection				

ABSOLUTE MAXIMUM RATINGS	
Short-circuit protection	48 Hours
Lead temperature 1mm from case for 10 seconds	260°C
Wave Solder	Wave Solder profile not to exceed the profile recommended in IEC 61760-1 Section 6.1.3. Please refer to application notes for further information.
Input voltage V _{IN} , MEJ1x03xxSC	5V
Input voltage V _{IN} , MEJ1x05xxSC	7V
Input voltage V _{IN} , MEJ1x12xxSC	15V
Input voltage V _{IN} , MEJ1x15xxSC	18V
Input voltage V _{IN} , MEJ1x24xxSC	28V

TECHNICAL NOTES**ISOLATION VOLTAGE**

'Hi Pot Test', 'Flash Tested', 'Withstand Voltage', 'Proof Voltage', 'Dielectric Withstand Voltage' & 'Isolation Test Voltage' are all terms that relate to the same thing, a test voltage, applied for a specified time, across a component designed to provide electrical isolation, to verify the integrity of that isolation.

Murata Power Solutions MEJ1 series of DC-DC converters are all 100% production tested at 5.2kVDC for 1 second and qualification tested at 7kVDC for 1 second, 5.2kVDC for 1 minute.

The MEJ1 series is recognised by Underwriters Laboratory, please see safety approval section for more information. When the insulation in the MEJ1 series is not used as a safety barrier, i.e. provides functional isolation only, continuous or switched voltages across the barrier up to 2.4kV are sustainable. This is established by measuring the partial discharge inception voltage in accordance with IEC 60270. Please contact Murata for further information.

REPEATED HIGH-VOLTAGE ISOLATION TESTING

It is well known that repeated high-voltage isolation testing of a barrier component can actually degrade isolation capability, to a lesser or greater degree depending on materials, construction and environment. We therefore strongly advise against repeated high voltage isolation testing, but if it is absolutely required, that the voltage be reduced by 20% from specified test voltage.

SAFETY APPROVAL**ANSI/AAMI ES60601-1**

The MEJ1 series have recognised by Underwriters Laboratory (UL) to ANSI/AAMI ES60601-1 and provides 1 MOOP (Means Of Operator Protection) based upon a working voltage of 200 Vrms max and 280 Vpk max., between Primary and Secondary and between Primary and its Enclosure, in a maximum ambient temperature of 85°C and/or case temperature limit of 130°C (case temperature measured on the face opposite the pins).

File Number E202895 applies.

UL60950

The MEJ1 series have been recognised by Underwriters Laboratory (UL) to UL60950 for basic/supplementary insulation to a working voltage of 200Vrms in a maximum ambient temperature of 85°C and/or case temperature limit of 130°C (case temperature measured on the face opposite the pins).

File number E151252 applies.

Creepage and clearance 2mm

Working altitude 4000m

FUSING

The MEJ1 Series of converters are not internally fused so to meet the requirements of UL an anti-surge input line fuse should always be used with ratings as defined below.

MEJ1x03xxSC 1A

MEJ1x05xxSC 1A

MEJ1x12xxSC 500mA

MEJ1x15xxSC 500mA

MEJ1x24xxSC 200mA

All fuses should be UL recognised and rated to at least the maximum allowable DC input voltage.

RoHS COMPLIANCE INFORMATION

This series is compatible with RoHS soldering systems with a peak wave solder temperature of 260°C for 10 seconds. Please refer to [application notes](#) for further information. The pin termination finish on this product series is Tin Plate, Hot Dipped over Matte Tin with Nickel Preplate. The series is backward compatible with Sn/Pb soldering systems. For further information, please visit www.murata-ps.com/rohs

ENVIRONMENTAL VALIDATION TESTING

The following tests have been conducted on this product series, as part of our design verification process. The datasheet characteristics specify user operating conditions for this series, please contact Murata if further information about the tests is required.

Test	Standard	Condition
Temperature cycling	MIL-STD-883 Method 1010, Condition B	10 cycles between two chambers set to achieve -55°C and +125°C. The dwell time shall not be less than 10min.
Humidity bias	JEDEC JESD22-A101	85°C ± 2°C, 85% ± 5% R.H. for >1000 hours.
Storage life	JEDEC JESD22-A103, Condition A	125°C +10/-0°C for ≥1000 hours.
Vibration	MIL-STD-883 Method 2007, Condition A	1.5mm pk-pk / 20g pk min, 20-2000Hz, 4 sweeps in each of 3 mutually perpendicular axis at 3 oct/min.
Shock	MIL-STD-883 Method 2002, Condition A	500g 1.0ms half sine, 5 shocks in each direction of 3 mutually perpendicular axes.
ESD	JEDEC JESD22-A114	HBM Testing Standard at 3 stress levels; 2.0kV, 4.0kV and 8.0kV.
Bump	IEC Class 4M5 of ETS 300 019-2-4	Shock Spectrum Type II, 6mS duration, 250m/s ² 500 bumps in 6 directions.
Solderability	IPC/ECA J-STD-002, Test A and A1	SnPb (Test A) For leaded solderability the parts are conditioned in a steam ager for 8 hours ±15 min. at a temperature of 93±3°C. Dipped in solder at 245°C ±5°C for 5 +0/-0.5 seconds. Pb-free (Test A1) For lead free solderability the parts are conditioned in a steam ager for 8 hours ± 15 min. at a temperature of 93±3°C. Dipped in solder at 255°C ±5°C for 5 +0/-0.5 seconds.
Solder heat	JEDEC JESD22-B106	The test sample is subjected to a molten solder bath at 260 ±5°C for 10 seconds (96SC tin/silver/copper).
Solder heat (hand)	MIL-STD-202 Method 210, Condition A	The soldering iron is heated to 350°C ± 10°C and applied to the terminations for a duration of 4 to 5 seconds.
Solvent cleaning	Resistance to cleaning agents.	Solvent – Novec 71IPA & Topklean EL-20A. Pulsed ultrasonic immersion 45°C- 65°C.
Solvent Resistance	MIL-STD-883 Method 2015	Separate samples subjected to solvent A, solvent B and solvent D.
Lead Integrity (Adhesion)	MIL-STD-883 Method 2025	Leads are bent through 90° until a fracture occurs.
Lead Integrity (Fatigue)	MIL-STD-883 Method 2004, condition B ₂	The leads are bent to an angle of 15°. Each lead is subjected to 3 cycles.
Lead Integrity (Tension/Pull)	MIL-STD-883 Method 2004, Condition A ₁	Pull of 0.227kg applied for 30 seconds. The force is then increased until the pins snap.

PART NUMBER STRUCTURE

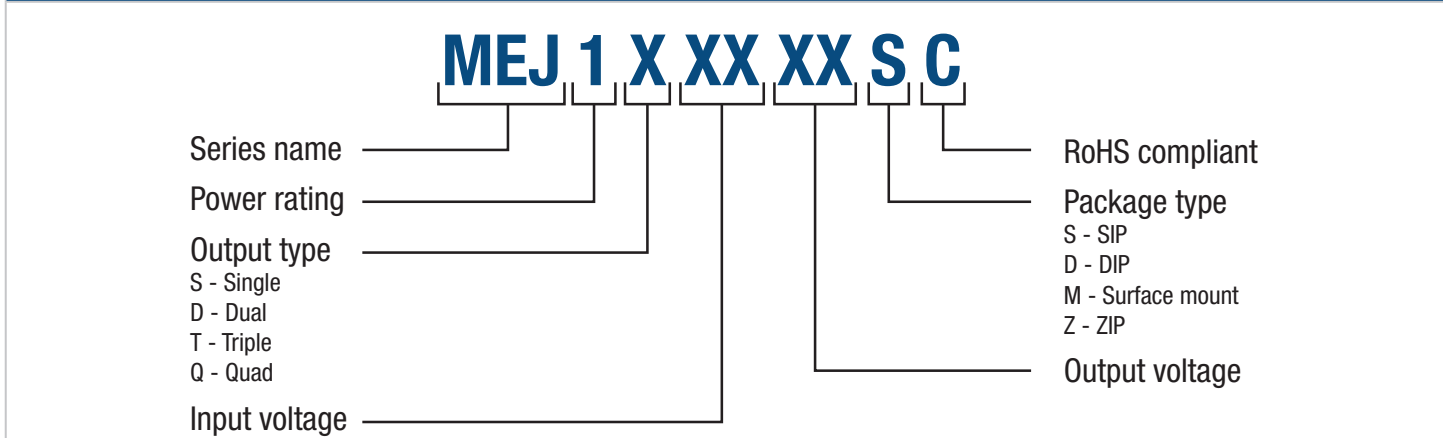

CHARACTERISATION TEST METHODS

Ripple & Noise Characterisation Method

Ripple and noise measurements are performed with the following test configuration.

C1	1µF X7R multilayer ceramic capacitor, voltage rating to be a minimum of 3 times the output voltage of the DC-DC converter
C2	10µF tantalum capacitor, voltage rating to be a minimum of 1.5 times the output voltage of the DC-DC converter with an ESR of less than 100mΩ at 100 kHz
C3	100nF multilayer ceramic capacitor, general purpose
R1	450Ω resistor, carbon film, ±1% tolerance
R2	50Ω BNC termination
T1	3T of the coax cable through a ferrite toroid
RLOAD	Resistive load to the maximum power rating of the DC-DC converter. Connections should be made via twisted wires

Measured values are multiplied by 10 to obtain the specified values.

Differential Mode Noise Test Schematic

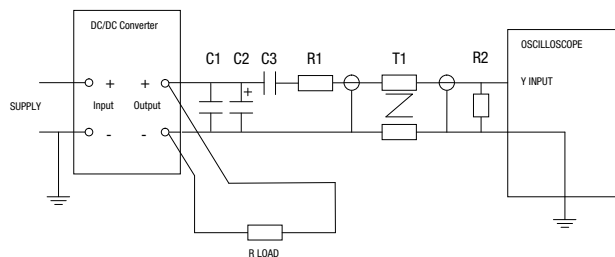

APPLICATION NOTES

Minimum load

The minimum load to meet datasheet specification is 10% of the full rated load across the specified input voltage range. Lower than 10% minimum loading will result in an increase in output voltage, which may rise to typically double the specified output voltage if the output load falls to less than 5%.

Gate Drive Applications Advisory Note

For general guidance for product usage in gate drive applications please refer to [“gate drive application notes”](#).

Capacitive loading and start up

Typical start up times for this series, with a typical input voltage rise time of 2.2µs and output capacitance of 10µF, are shown in the table below. The product series will start into a capacitance of 47µF with an increased start time, however, the maximum recommended output capacitance is 10µF.

Typical Start-Up Wave Form

Start-up time		Start-up time		Start-up time	
µs		µs		µs	
MEJ1S0303SC	900	MEJ1S1509SC	2400	MEJ1D1205SC	1200
MEJ1S0305SC	2000	MEJ1S1512SC	2700	MEJ1D1209SC	3600
MEJ1S0503SC	500	MEJ1S1515SC	3800	MEJ1D1212SC	3900
MEJ1S0505SC	2000	MEJ1S2405SC	1700	MEJ1D1215SC	6000
MEJ1S0509SC	3200	MEJ1S2409SC	2300	MEJ1D1505SC	1200
MEJ1S0512SC	7500	MEJ1S2412SC	2200	MEJ1D1509SC	3200
MEJ1S0515SC	10500	MEJ1S2415SC	3600	MEJ1D1512SC	3300
MEJ1S1203SC	600	MEJ1D0503SC	700	MEJ1D1515SC	4800
MEJ1S1205SC	1200	MEJ1D0505SC	1600	MEJ1D2405SC	1100
MEJ1S1209SC	2900	MEJ1D0509SC	3700	MEJ1D2409SC	2000
MEJ1S1212SC	2900	MEJ1D0512SC	4200	MEJ1D2412SC	3300
MEJ1S1215SC ¹	3900	MEJ1D0515SC	7000	MEJ1D2415SC	6400
MEJ1S1505SC	1100	MEJ1D1203SC	600		

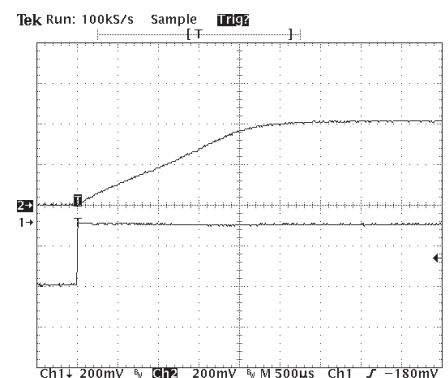

1. The MEJ1S1215SC have been tested to 150µF and will operate within datasheet specifications with an increased start up time, please contact Murata for information about other variants.

TOLERANCE ENVELOPES

The voltage tolerance envelope shows typical load regulation characteristics for this product series. The tolerance envelope is the maximum output voltage variation due to changes in output loading.

DUAL 1203, 1515, 2412, SINGLE 0303, 0305, 1203

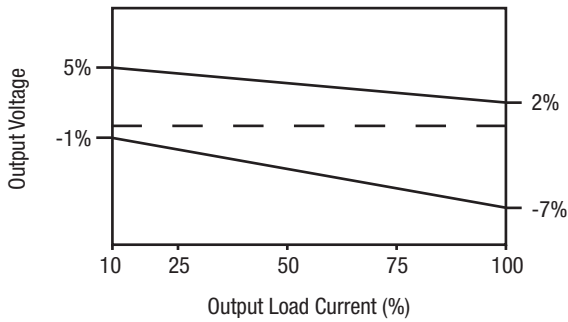

DUAL 1209, 1509, 2409

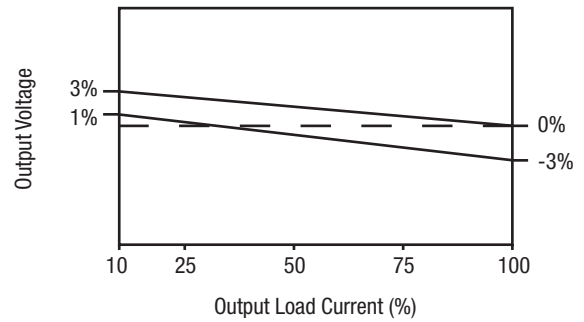

DUAL 0515, SINGLE 1515, 2415

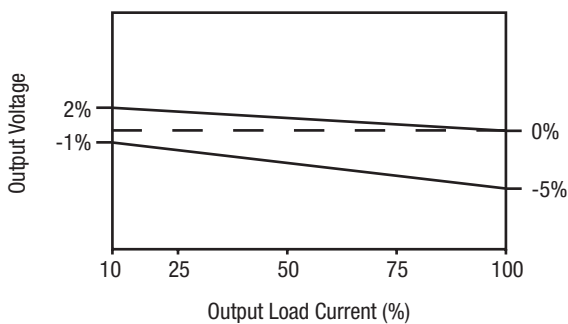

DUAL 1512, SINGLE 1212, 1512, 2412

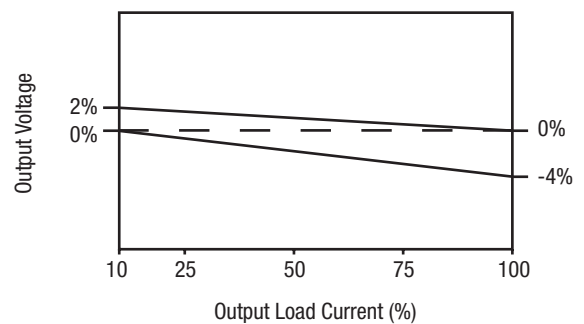

DUAL 0512, SINGLE 1209, 1509

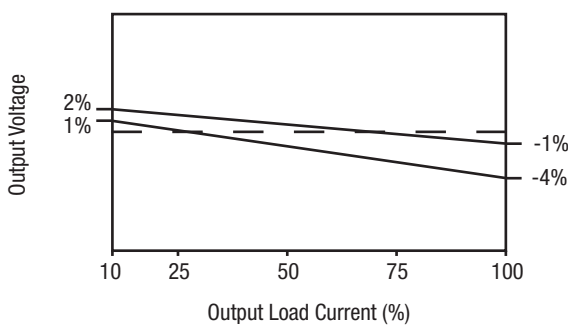

DUAL 1212, 1215, 2415, SINGLE 0509, 0512, 1215, 2409

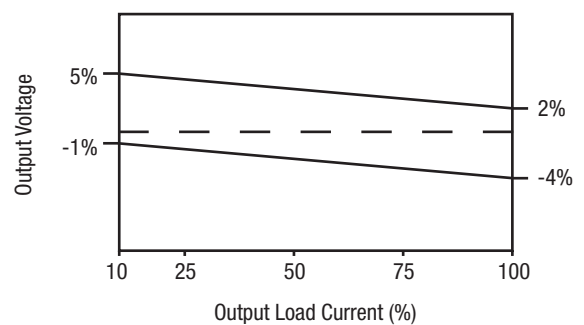

TOLERANCE ENVELOPES (Continued)

SINGLE 1205, 1505, 2405, 0515

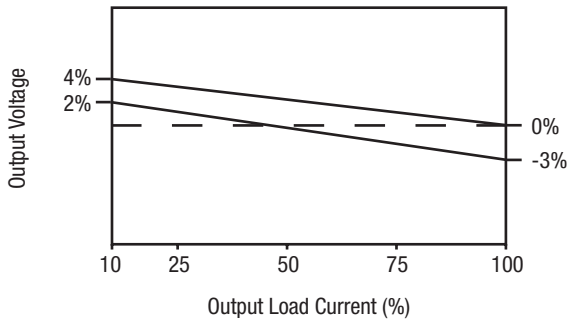

DUAL 1205, 0505, 1505, 2405

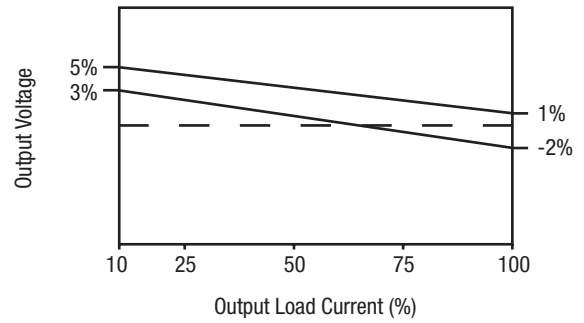

DUAL 0509, 0503, SINGLE 0503, 0505

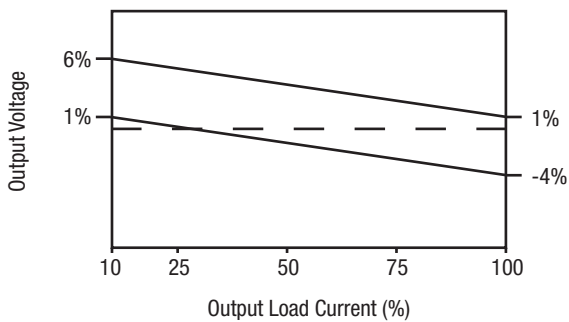

TEMPERATURE DERATING GRAPH

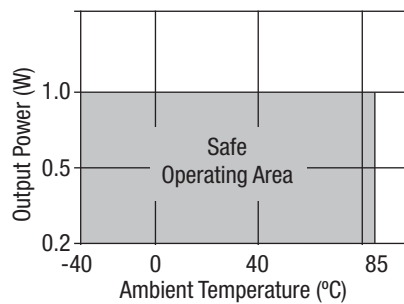

EFFICIENCY VS LOAD Single Output

3.3V Input

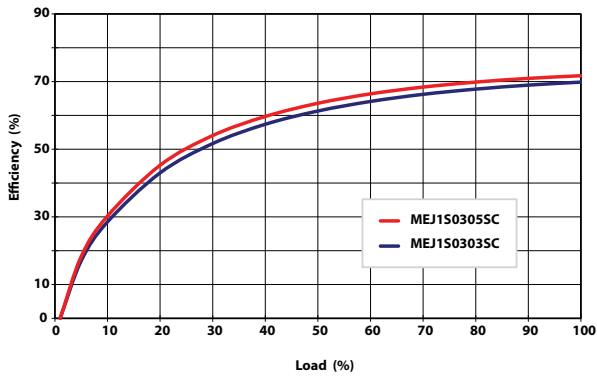

5V Input

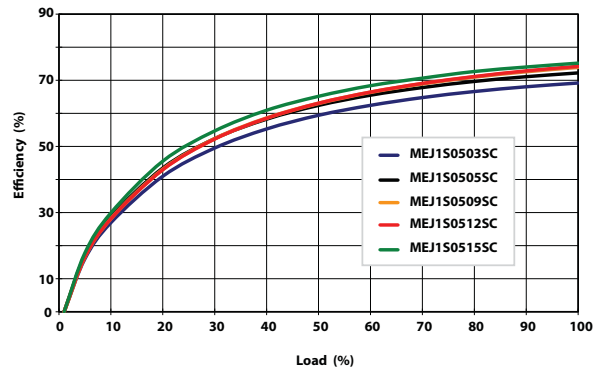

12V Input

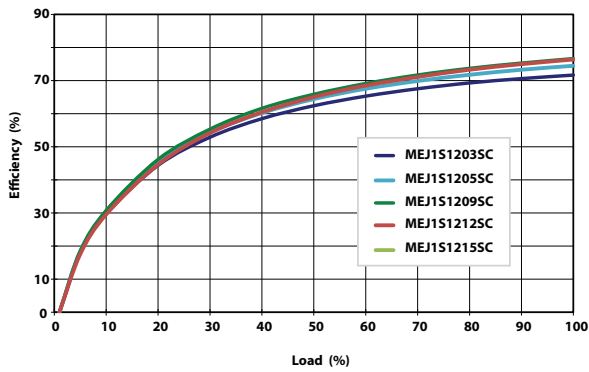

15V Input

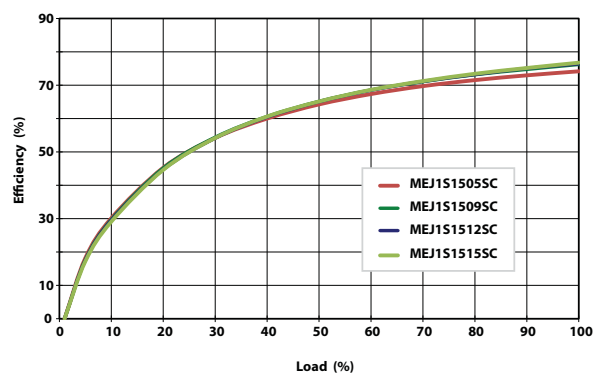

24V Input

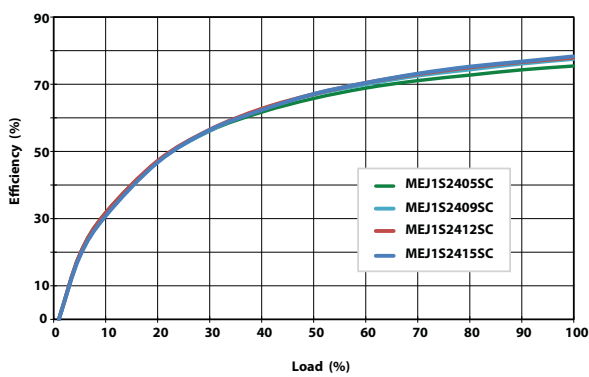

EFFICIENCY VS LOAD Dual Output

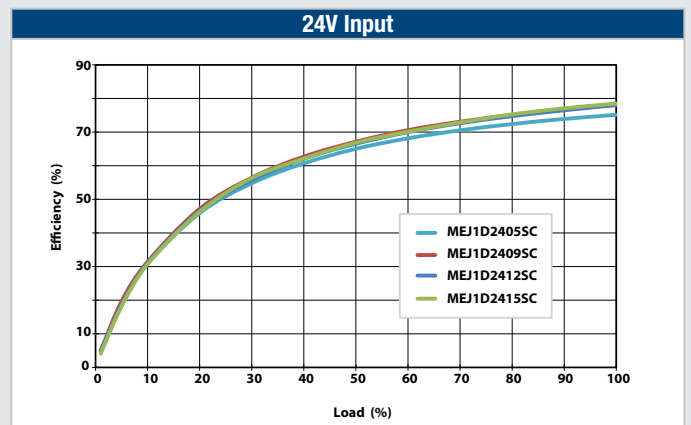
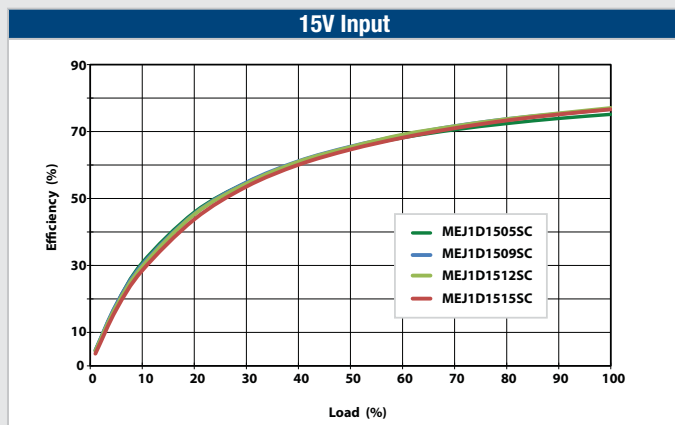
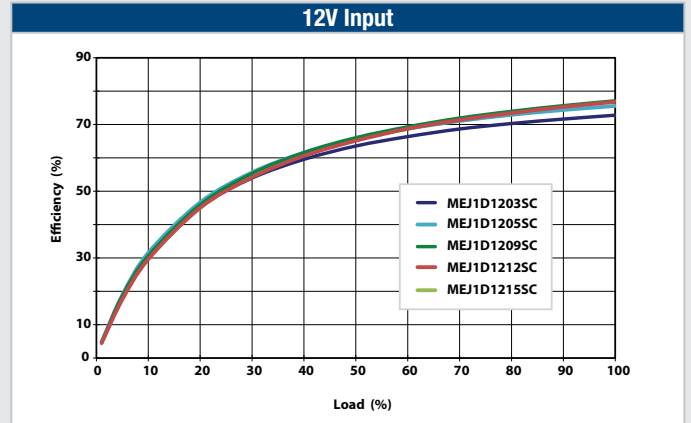
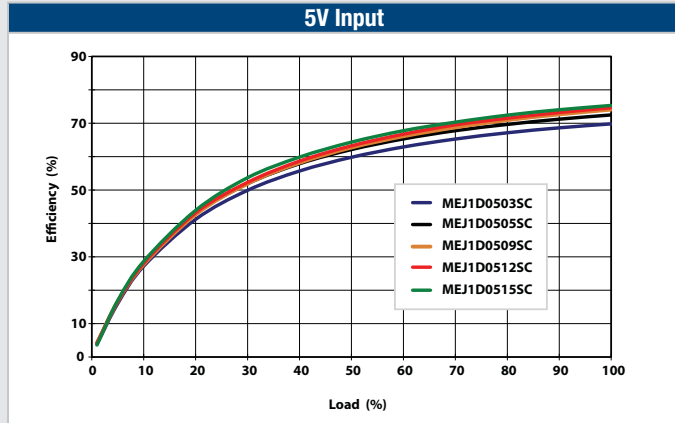

PACKAGE SPECIFICATIONS

MECHANICAL DIMENSIONS

All dimensions in mm ± 0.25 mm (inches ± 0.01). All pins on a 2.54 (0.1) pitch and within ± 0.25 (0.01) of true position.
 * Pin not fitted on single output variants.

Weight: 4.3g

PIN CONNECTIONS

Single Output

Pin	Function
1	+Vin
2	-Vin
5	-Vout
7	+Vout

Dual Output

Pin	Function
1	+VIN
2	-VIN
5	-VOUT
6*	OV
7	+VOUT

TUBE OUTLINE DIMENSIONS

Unless otherwise stated all dimensions in mm ± 0.5 mm (inches ± 0.02).
 Tube length : 20.669±0.079 (525mm±2mm). Tube Quantity : 25

RECOMMENDED FOOTPRINT DETAILS

* Hole not required for single output variants.
 All dimensions in mm ± 0.25 mm (inches ± 0.01).

DISCLAIMER

Unless otherwise stated in the datasheet, all products are designed for standard commercial and industrial applications and NOT for safety-critical and/or life-critical applications.

Particularly for safety-critical and/or life-critical applications, i.e. applications that may directly endanger or cause the loss of life, inflict bodily harm and/or loss or severe damage to equipment/property, and severely harm the environment, a prior explicit written approval from Murata is strictly required. Any use of Murata standard products for any safety-critical, life-critical or any related applications without any prior explicit written approval from Murata shall be deemed unauthorised use.

These applications include but are not limited to:

- Aircraft equipment
- Aerospace equipment
- Undersea equipment
- Power plant control equipment
- Medical equipment
- Transportation equipment (automobiles, trains, ships, etc.)
- Traffic signal equipment
- Disaster prevention / crime prevention equipment
- Data Processing equipment

Murata makes no express or implied warranty, representation, or guarantee of suitability, fitness for any particular use/purpose and/or compatibility with any application or device of the buyer, nor does Murata assume any liability whatsoever arising out of unauthorised use of any Murata product for the application of the buyer. The suitability, fitness for any particular use/purpose and/or compatibility of Murata product with any application or device of the buyer remain to be the responsibility and liability of the buyer.

Buyer represents and agrees that it has all the necessary expertise to create and implement safeguards that anticipate dangerous consequences of failures, monitor failures and their consequences, lessen the likelihood of failures that might cause harm, and take appropriate remedial actions. Buyer will fully indemnify and hold Murata, its affiliated companies, and its representatives harmless against any damages arising out of unauthorised use of any Murata products in any safety-critical and/or life-critical applications.

Remark: Murata in this section refers to Murata Manufacturing Company and its affiliated companies worldwide including, but not limited to, Murata Power Solutions.



This product is subject to the following [operating requirements](#) and the [Life and Safety Critical Application Sales Policy](#):

Refer to: <https://www.murata.com/en-eu/products/power/requirements>

Murata Power Solutions (Milton Keynes) Ltd. makes no representation that the use of its products in the circuits described herein, or the use of other technical information contained herein, will not infringe upon existing or future patent rights. The descriptions contained herein do not imply the granting of licenses to make, use, or sell equipment constructed in accordance therewith. Specifications are subject to change without notice.

© 2024 Murata Power Solutions (Milton Keynes) Ltd.