

8

7

6

5

4

3

2

1

VICOR CONFIDENTIAL

THIS DOCUMENT AND THE DATA DISCLOSED HEREIN OR HEREWITH IS NOT TO BE REPRODUCED, USED OR DISCLOSED IN WHOLE OR IN PART TO ANYONE WITHOUT THE PERMISSION OF VICOR CORP.

REVISIONS

REV	DESCRIPTION	DATE	APPROVED
5	RELEASED PER E064554	10/09/06	JSR MB
6	REVISED PER E101020	08/19/10	KUK DCS

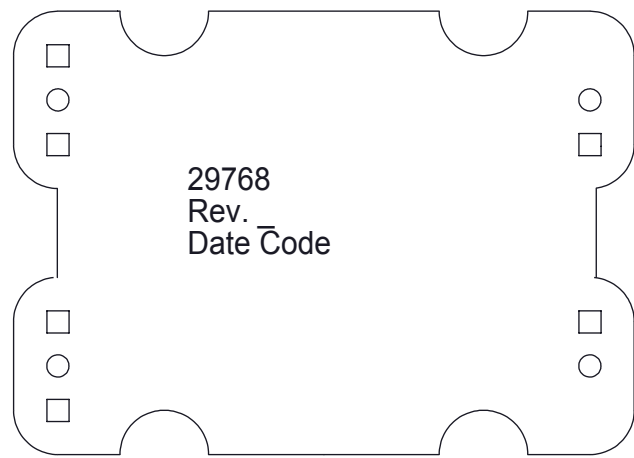

TOP VIEW
SEE NOTE 6

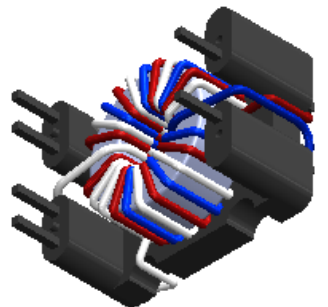
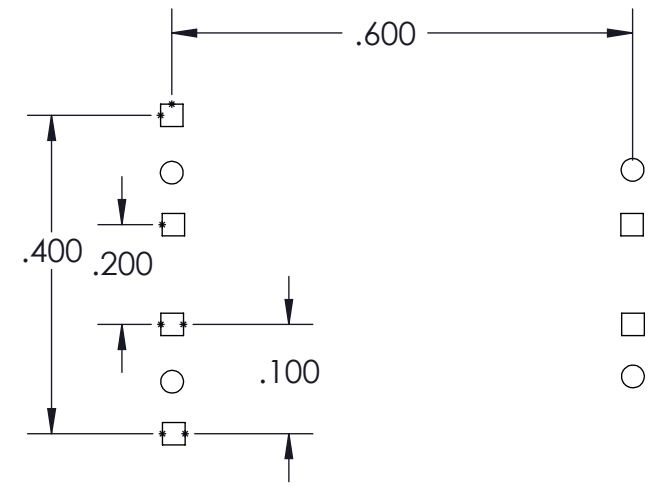
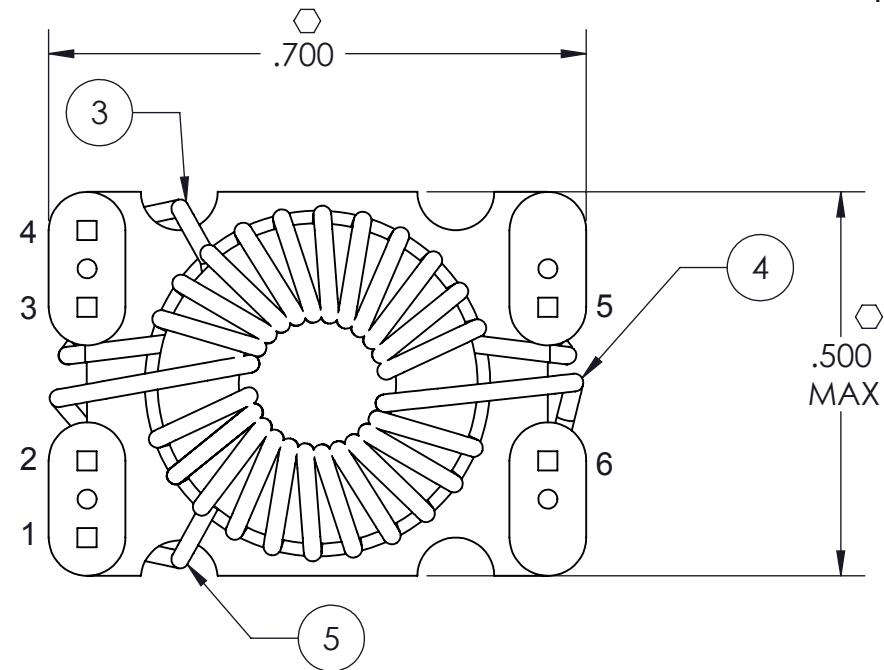
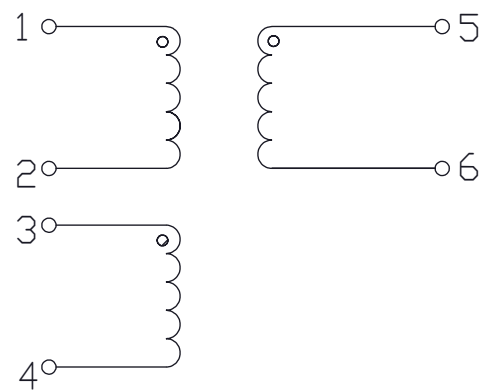
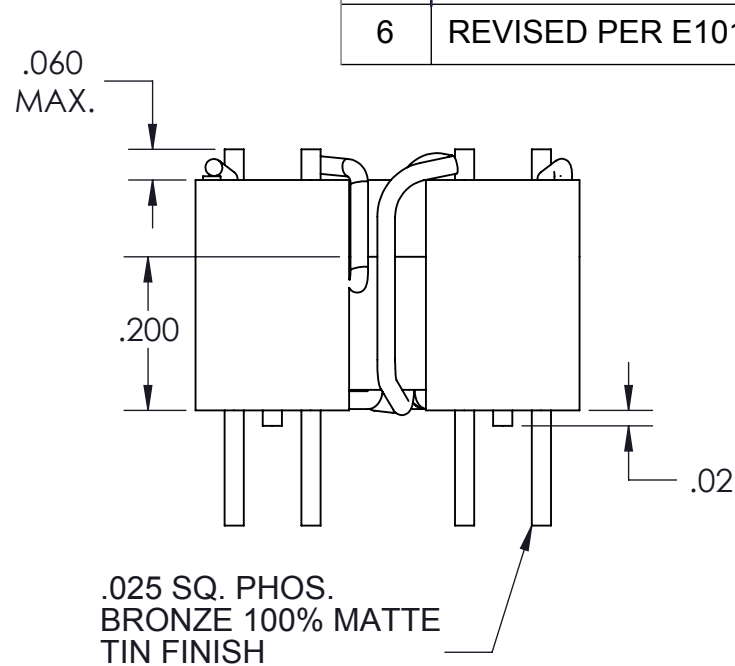
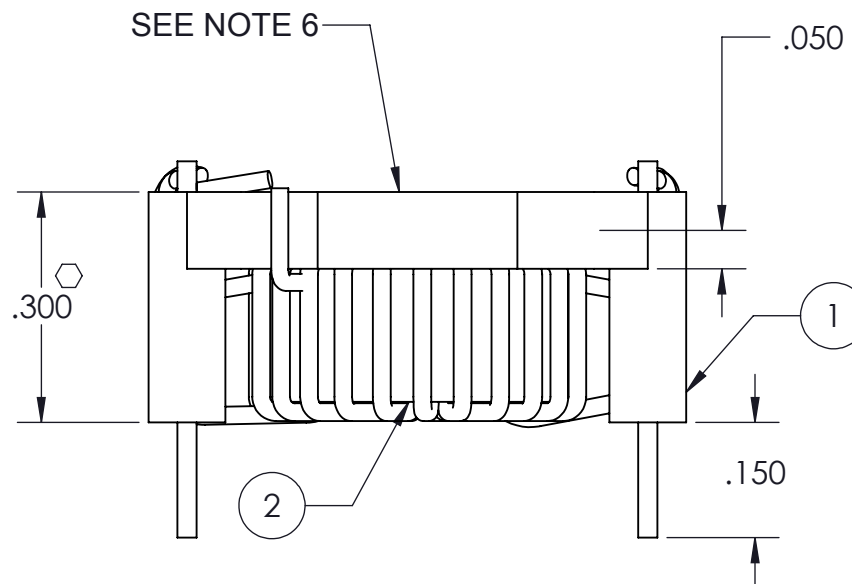

- NOTES:
 1. ASSEMBLY TO BE FREE OF NICKS.
 2. WINDINGS TO BE EVENLY SPACED.
 3. RoHS COMPLIANT, LEAD FREE PER CST-0001 LATEST REVISION.
 4. GENERAL WORKMANSHIP STANDARDS FOR MAGNETIC COMPONENTS PER WS-0002.
 5. DENOTES CRITICAL CHARACTERISTIC FOR LOT INSPECTION.
 6. PART NUMBER INFORMATION TO BE MARKED ON SURFACE INDICATED.
 7. DIMENSIONS ARE INCHES ONLY.

PINS	ITEM NO.	WINDING	NO. OF TURNS	IND.(uH)	DC RES (mΩ)	TEST
PINS 1&2	5	RED PRI.	8T OF #29 AWG.	101 - 187	40 - 50	100 KHz
PINS 3&4	3	WHITE PRI.	8T OF #29 AWG.	101 - 187	40 - 50	@ 1 VAC
PINS 5&6	4	BLUE 1 SEC.	8T OF #29 AWG.	101 - 187	40 - 50	

DRAWN	DATE
P.E.IENI	11/07/05
MATERIAL	UNLESS OTHERWISE SPECIFIED DIMENSIONS ARE INCH [MM] TOLERANCES ARE: DECIMALS ANGLES X.XX [X.X] = ±0.01 [0.25] ±1° X.XXX [X.XX] = ±0.005 [0.127]
FINISH	
THIRD ANGLE PROJECTION	
DO NOT SCALE DRAWING	

IND TOR PR BUS 3W ASSY DWG P/N 29768			
SIZE	CAGE CODE	DWG NO	REV
B	67131	29775	6
SCALE 4: 1		SHEET 1 OF 1	

8

7

6

5

4

3

2

1