

# 3: Handles

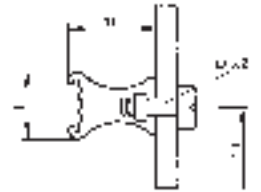

## 3.1 Fluted Handles

- Extruded aluminium handles, shaped to facilitate withdrawal of plug-in units
- Two grooves in the front face will accept identification strips (0.5 x 9 mm)
- **Scope of delivery:**
  - Extruded handle, clear anodised
  - Assembly material



### 3.1 Fluted Handles for Front Panels to IEC 60297

Front Panel Width HP	Width		Handle Length		Part-No.
	mm	inch	mm	inch	
3 HP	15.1	0.59	12.5	0.49	60-103
4 HP	20.1	0.79	17.6	0.69	60-104
5 HP	25.2	0.99	22.6	0.88	60-105
6 HP	30.3	1.19	27.7	1.09	60-106
7 HP	35.3	1.38	33.5	1.31	60-107
8 HP	40.5	1.59	37.9	1.49	60-108
10 HP	50.6	1.99	48.0	1.88	60-110
12 HP	60.8	2.39	58.2	2.29	60-112
14 HP	70.9	2.79	69.1	2.72	60-114
16 HP	81.1	3.19	78.5	3.09	60-116
20 HP	101.4	3.99	98.8	3.88	60-120
21 HP	106.4	4.18	104.6	4.11	60-121
27 HP	137.0	5.39	134.4	5.29	60-127
30 HP	152.2	5.99	149.6	5.88	60-130
40 HP	203.0	7.99	200.4	7.88	60-140
60 HP	304.6	11.99	302.0	11.88	60-160
84 HP	426.5	16.79	424.0	16.69	60-184

### 3.1.1 Fluted Handles for Cassettes and Modules With Front Panels to IEC 60297

7 HP	10 HP	14 HP	21 HP	28 HP	42 HP
23-060	23-061	23-062	23-063	23-064	23-065

Incl. assembly material

# 3: Handles



## 3.2 Rigid-Mounted Unit Handles

- Shape/finish and mounting position which correspond to those of the injector/ejector handles
- 4 HP to 12 HP injection-moulded in black glass reinforced Nylon (UL94 V-0)
- 14 HP to 84 HP are extruded in black Noryl (UL94 V-0)
- Aluminium identification labels are inserted into a slot in the handle
- Handles are fixed to the front panels using self-tapping, self-centering screws
- Handles for 4 HP have positioning nipples, allowing them to be fixed with one screw, without turning
- Width greater than 4 HP, at least two screws must be used for fixing
- Grooves on the handle always point towards the middle of the unit
- **Scope of delivery:**
  - Rigid-mounted handle
  - Identification label

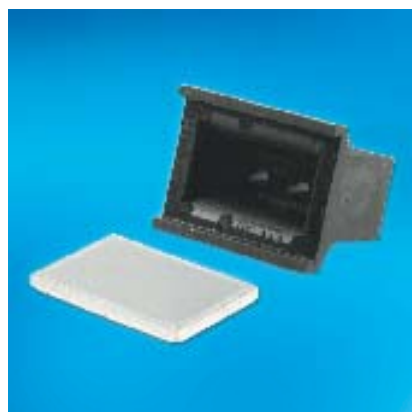
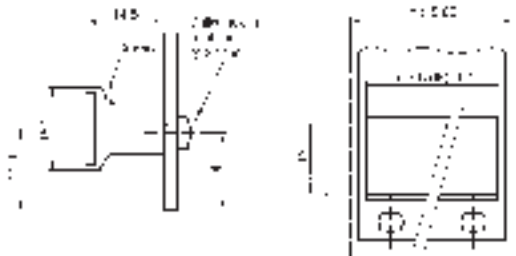

### 3.2 Rigid-Mounted Handle with Identification Label

Width	Scope of Delivery	Part-No.
4 HP top*	5 pcs.	60-200-01
4 HP bottom*	5 pcs.	60-200-02
4 HP	10 pcs.	60-200-04
5 HP	10 pcs.	60-200-05
6 HP	10 pcs.	60-200-06
7 HP	10 pcs.	60-200-07
8 HP	10 pcs.	60-200-08
10 HP	10 pcs.	60-200-10
12 HP	10 pcs.	60-200-12
14 HP	1 pc.	60-200-14
21 HP	1 pc.	60-200-21

- Other sizes (up to 84 HP) are available on request
- \* (Flat front panel with card holder)

#### 3.2.1 Assembly Material

Recessed round head screw	100 pcs.	1902-70
---------------------------	----------	---------

# 3: Handles



## 3.3 Injector/Ejector Handles acc. to IEC

- Inject/eject function: Allows trouble-free insertion and extraction of electronic units with multi-pole connectors
- Inject and eject handle is injection moulded black, glass-reinforced Nylon (UL94 V-0)
- Anodised aluminium identification label is snapped into a slot on the handle
- The unit is extracted by pressing the handle outwards, and inserted by pressing the handle inwards
- The insert function is patented
- PC cards can be mounted both in the standard position and off-set 1 HP (5.08 mm/0.20 inch)
- Front panel with special cut-outs has to be ordered separately
- 3 U  $\hat{=}$  set for 1 handle, 6 U and 9 U  $\hat{=}$  set for 2 handles
- **Scope of delivery:**
  - Injector/ejector handle
  - Identification label
  - Catch plate
  - Assembly material

### Standard mounting    Offset mounting

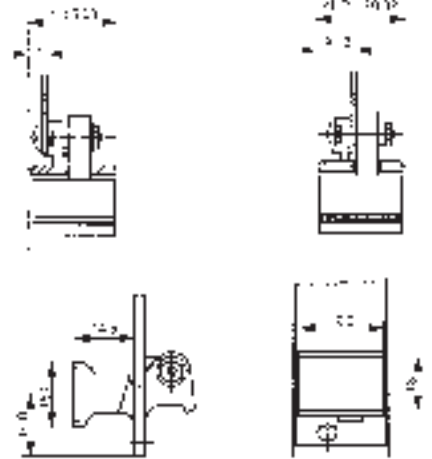

### Injector/Ejector Handle Complete, with Catch Plate

Description	3 U	6 U
Injector/ejector handle complete, with catch plate	63-358	63-359

### Rest Position Handle

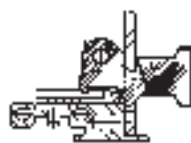

### Inject Handle

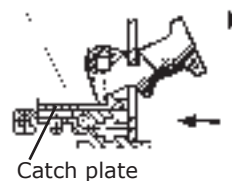

### Eject Handle



### Mounting of Catch Plate

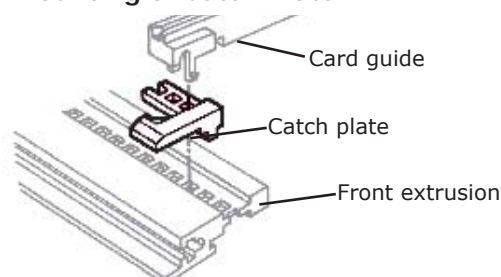

# 3: Handles

In use with part front panels for plug-in units

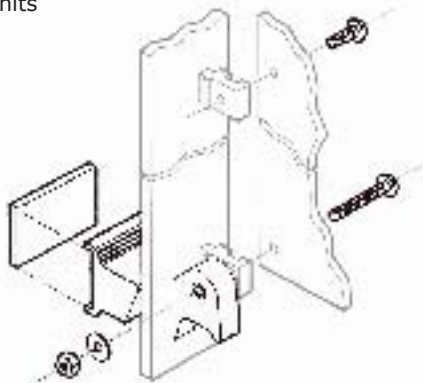

Card holder for use with flat front panels has to be ordered separately

## Single Parts Injector/Ejector Handle

Description	Scope of Delivery	Part-No.
Injector/ejector handle bottom	100 pcs.	63-451
Injector/ejector handle top	100 pcs.	63-450
Label	100 pcs.	63-454
Bush	100 pcs.	63-667
Bearing piece bottom (catch plate)	100 pcs.	63-452
Bearing piece top (catch plate)	100 pcs.	63-453
Slotted pan head screw M2.5 x 6	100 pcs.	1901-06
Slotted pan head screw M2.5 x 16	100 pcs.	1901-16
Hexagonal lock nut M2.5	100 pcs.	1907-04
Washer Ø 2.8/7 x 0.5	100 pcs.	1907-01

# 3: Handles



## 3.4 Injector/Ejector Handles acc. to IEEE

### 3.4.1 Ergonomic IEEE Standard Injector/Ejector Handle

- Without latching (standard)
- **Scope of delivery:**
  - Handle black (plastic, UL94 V-0)
  - Card holder (zinc die-cast, galvanized)
  - Reset spring (stainless steel)
  - Assembly material (screws M2.5 for fixing of card holder/printed board/front panel)
- Grey handles available on request

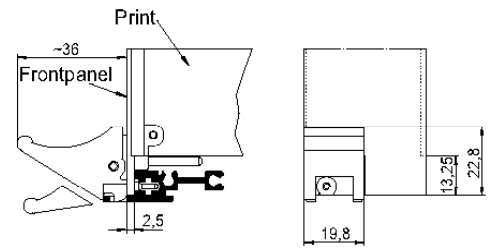

**Injector/Ejector Handle Top with ESD Pin**

Description	Part-No.
	1 pc.
Black	81-075



**Injector/Ejector Handle Top without ESD Pin**

Description	Part-No.
	1 pc.
Black	81-075-01



**Injector/Ejector Handle Bottom with ESD Pin**

Description	Part-No.
	1 pc.
Black	81-076



**Injector/Ejector Handle Bottom without ESD Pin**

Description	Part-No.
	1 pc.
Black	81-076-01

**Label 18.5 x 10 mm**

1 sheet A4 with 280 labels	81-030
----------------------------	--------

Label position

# 3: Handles

## 3.4.2 Ergonomic IEEE Hot-Swap Injector/Ejector Handle

- With latching (hot-swap)
- **Scope of delivery:**
  - Handle black, button red (plastic, UL94 V-0)
  - Card holder (zinc die-cast, galvanized)
  - Reset spring (stainless steel)
  - Assembly material (screws M2.5 for fixing of card holder/printed board)
- Grey handles available on request
- Offset version:
  - Offset by 2.54 mm (1/2 HP) to the right
  - Thus giving more space on the solder side of the PCB

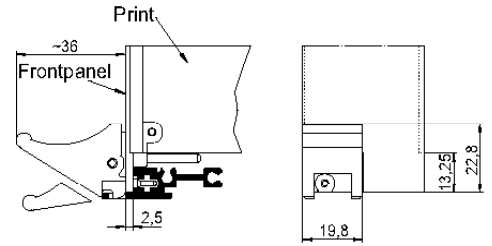

### Top Handle *with* ESD Pin

Description	Part-No. 1 pc.
Black	81-095
Black offset	81-184

Optional screws for fixing front panels: M2.5, 100 pcs: Cross recessed 1904-41 (12.7 mm), Torx: 1904K41 (11.3 mm)



### Top Handle *without* ESD pin

Description	Part-No. 1 pc.
Black	81-095-01

Optional screws for fixing front panels: M2.5, 100 pcs: Cross recessed 1904-41 (12.7 mm), Torx: 1904K41 (11.3 mm)



### Bottom Handle *with* ESD Pin

Description	Part-No. 1 pc.
Black	81-096
Black offset	81-185

Optional screws for fixing front panels: M2.5, 100 pcs: Cross recessed 1904-41 (12.7 mm), Torx: 1904K41 (11.3 mm)



### Bottom Handle *without* ESD Pin

Description	Part-No. 1 pc.
Black	81-096-01

Optional screws for fixing front panels: M2.5, 100 pcs: Cross recessed 1904-41 (12.7 mm), Torx: 1904K41 (11.3 mm)



### Microswitch for Injector/Ejector Handle

- Technical data and function see 3.4.7

Description	Part-No. 1 pc.
Microswitch with pre-assembled wire cable length (25 mm)	81-088

### Label 18.5 x 10 mm

1 sheet A4 with 280 labels	81-030
----------------------------	--------

# 3: Handles

## 3.4.3 Classic IEEE Standard and Hot-Swap Injector/Ejector Handle

- Without latching (standard)
- **Scope of delivery:**
  - Handle black, without button (plastic, UL94 V-0)
  - Card holder (zinc die-cast, galvanized)
  - Reset spring (stainless steel)
  - Assembly material (screws M2.5 for fixing of card holder/printed board)
- Offset version:
  - Offset by 2.54 mm (1/2 HP) to the right
  - Thus giving more space on the solder side of the PCB

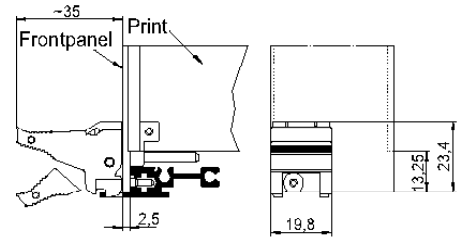

**Top Handle with ESD Pin**

Description	Part-No. 1 pc.
Black	81-260
Black offset	81-160

Optional screws for fixing front panels: M2.5, 100 pcs: Cross recessed 1904-41 (12.7 mm), Torx: 1904K41 (11.3 mm)



**Bottom Handle with ESD Pin**

Description	Part-No. 1 pc.
Black	81-261
Black offset	81-161

Optional screws for fixing front panels: M2.5, 100 pcs: Cross recessed 1904-41 (12.7 mm), Torx: 1904K41 (11.3 mm)

- With latching (hot-swap)
- **Scope of delivery:**
  - Handle black, button light grey (plastic, UL94 V-0)
  - Card holder (die-cast tin, galvanized)
  - Assembly material (screws M2.5 for fixing of card holder/printed board)
- Offset version:
  - Offset by 2.54 mm (1/2 HP) to the right
  - Thus giving more space on the solder side of the PCB



**Top Handle with ESD Pin**

Description	Part-No. 1 pc.
Black	81-255
Black offset	81-155

Optional screws for fixing front panels: M2.5, 100 pcs: Cross recessed 1904-41 (12.7 mm), Torx: 1904K41 (11.3 mm)



**Bottom Handle with ESD Pin**

Description	Part-No. 1 pc.
Black	81-256
Black offset	81-156

Optional screws for fixing front panels: M2.5, 100 pcs: Cross recessed 1904-41 (12.7 mm), Torx: 1904K41 (11.3 mm)



**Microswitch for Injector/Ejector Handle**

- Technical data and function see 3.4.7

Description	Part-No. 1 pc.
Microswitch with pre-assembled wire cable length (25 mm)	81-088

# 3: Handles

## 3.4.4. Telecom Hot-Swap Injector/Ejector Handle

- With latching (hot-swap)
- **Scope of delivery:**
  - Handle black, button red (plastic, UL94 V-0)
  - Card holder (zinc die-cast, galvanized)
  - Assembly material (screws M2.5 for fixing of card holder/printed board)
- Grey handles available on request
- Offset version:
  - Offset by 2.54 mm (1/2 HP) to the right
  - Thus giving more space on the solder side of the PCB

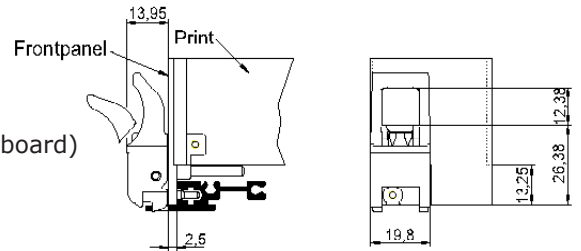

### Top Handle *with* ESD Pin

Description	Part-No. 1 pc.
Black	81-205
Black offset	81-188

Optional screws for fixing front panels: M2.5, 100 pcs: Cross recessed 1904-41 (12.7 mm), Torx: 1904K41 (11.3 mm)



### Top Handle *without* ESD pin

Description	Part-No. 1 pc.
Black	81-205-01

Optional screws for fixing front panels: M2.5, 100 pcs: Cross recessed 1904-41 (12.7 mm), Torx: 1904K41 (11.3 mm)



### Bottom Handle *with* ESD Pin

Description	Part-No. 1 pc.
Black	81-206
Black offset	81-189

Optional screws for fixing front panels: M2.5, 100 pcs: Cross recessed 1904-41 (12.7 mm), Torx: 1904K41 (11.3 mm)



### Bottom Handle *without* ESD Pin

Description	Part-No. 1 pc.
Black	81-206-01

Optional screws for fixing front panels: M2.5, 100 pcs: Cross recessed 1904-41 (12.7 mm), Torx: 1904K41 (11.3 mm)



### Microswitch for Injector/Ejector Handle

- Technical data and function see 3.4.7

Description	Part-No. 1 pc.
Microswitch with pre-assembled wire cable length (25 mm)	81-088



# 3: Handles

## 3.4.5 Telecom Long Hot-Swap Injector/Ejector Handle

- With latching (hot-swap)
- **Scope of delivery:**
  - Handle black, button red (plastic, UL94 V-0)
  - Card holder (zinc die-cast, galvanized)
  - Assembly material (screws M2.5 for fixing of card holder/printed t
- Grey handles available on request
- Offset version:
  - Offset by 2.54 mm (1/2 HP) to the right
  - Thus giving more space on the solder side of the PCB

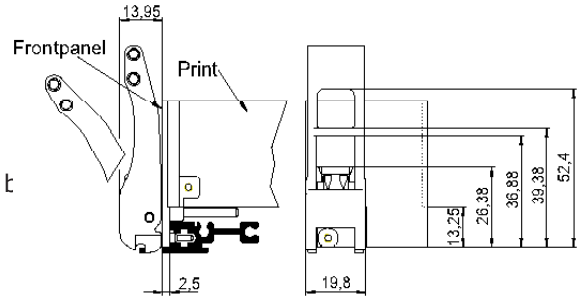

### Top Handle *with ESD Pin*

Description	Part-No. 1 pc.
Black	81-214
Black offset	81-117

Optional screws for fixing front panels: M2.5, 100 pcs: Cross recessed 1904-41 (12.7 mm), Torx: 1904K41 (11.3 mm)



### Bottom Handle *with ESD pin*

Description	Part-No. 1 pc.
Black	81-215
Black offset	81-116

Optional screws for fixing front panels: M2.5, 100 pcs: Cross recessed 1904-41 (12.7 mm), Torx: 1904K41 (11.3 mm)



### Microswitch for Injector/Ejector Handle

- Technical data and function see 3.4.7

Description	Part-No. 10 pc.
Microswitch with pre-assembled wire cable length (25 mm)	81-088

# 3: Handles

## 3.4.6 Cutouts and Function

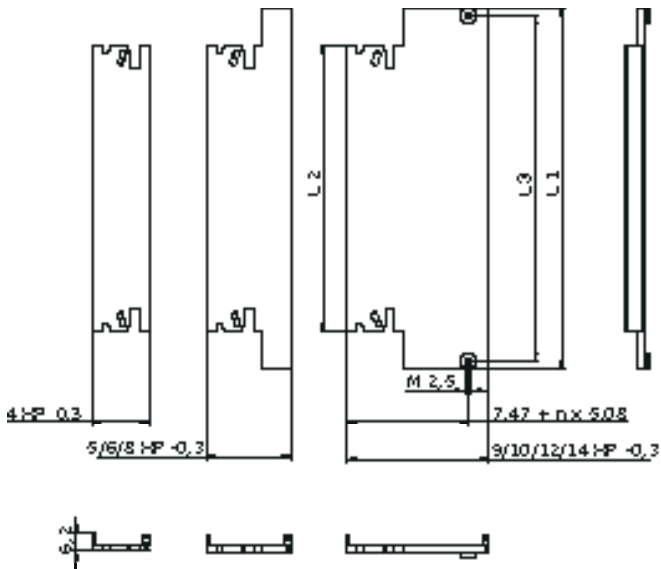

Injector/Ejector Handle Without Locking Feature (Function)

Injector/Ejector Handle With Locking Feature (Function)

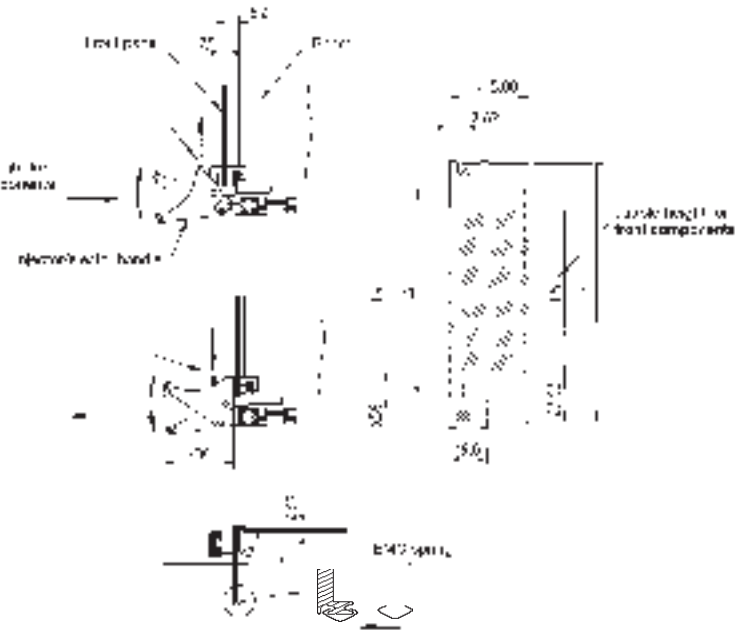
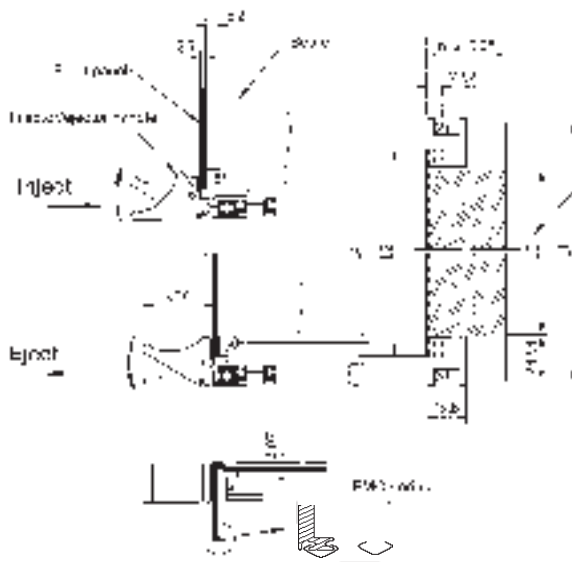

# 3: Handles

## Injector/Ejector Offset Handle With Locking Feature (Function)

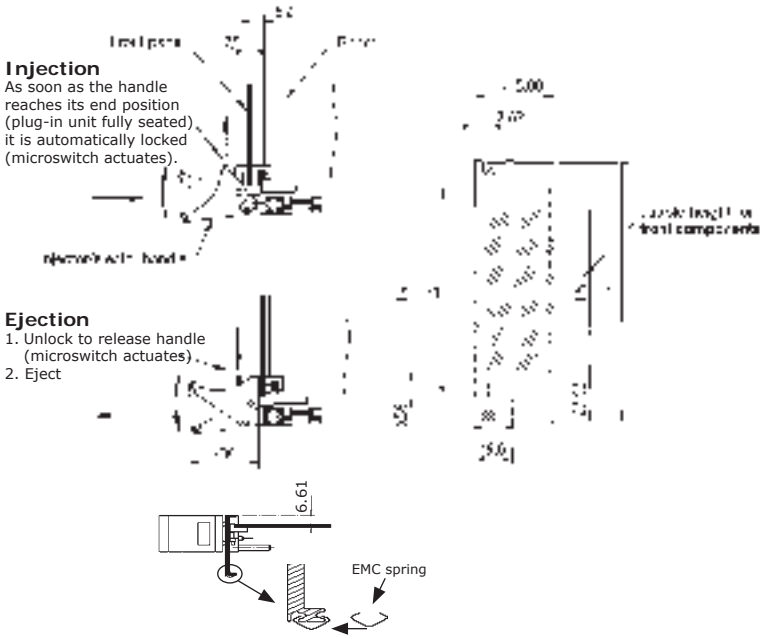

### Dimensions

Height	L1 mm	L1 inch	L2 mm	L2 inch	L3 mm	L3 inch	L4 mm	L4 inch	L5 mm	L5 inch
3 U	128.55	5.06	102.05	4.01	122.50	4.82	88.90	3.50	81.30	3.20
6 U	261.90	10.31	235.40	9.27	255.85	10.07	222.25	8.75	214.65	8.45
9 U	395.25	15.56	368.75	14.51	389.20	15.32	355.60	14.00	348.00	13.70

### 3.4.7 Microswitch Technical Data and Function



#### Microswitch for Injector/Ejector Handle

Description	Part-No. 1 pc.
Microswitch with pre-assembled wire cable length (25 mm)	81-088

#### Technical data

Life circuit:	30 V DC, 5 - 50 mA	30'000 cycles
	60 V DC, 5 mA	30'000 cycles
	60 V DC, 500 mA	15'000 cycles
Temperature:	-25°C to +70°C	
Humidity:	RH 85% max.	
Vibration:	10 Hz to 55 Hz, 18 g	
Shock:	30 g, 11 msec	

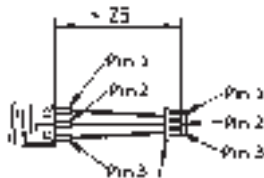

Molex Plug  
Part-No. 51021-0300

Mates with: 51047-0300  
(Molex P/N) 53048-0310  
53047-0310  
53261-0390  
53398-0390

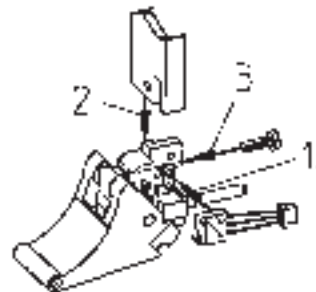

Note: Microswitch orientation

#### Switch function:

- Switch open: Connection between Pin 1 and Pin 3
- Switch closed: Connection between Pin 1 and Pin 2

#### Mounting sequence:

1. Push microswitch onto the handle
2. Insert the front panel into the handle
3. Screw-on

# 3: Handles

## Hot-Swap Safely at the Touch of a Button

Modern backplanes are equipped with high pin density connectors. In order to manage the occurring high connecting forces, up to 500 N (100lbs.) for a 6U plug-in unit, a new insertion/extraction handle was designed and standardized in IEEE 1101.10.

The standards for CompactPCI Hot Swap and VME64x show new features added to the IEEE handle. To meet these different demands, Elma has developed two handles.

To confirm with IEEE 1101.10 and CompactPCI without Hot Swap or other applications where high insertion/extraction forces have to be managed, Elma developed a handle with an optimized ratio of leverage that impairs minimum vertical forces to the rack. Thus preventing the front extrusions from buckling which can cause malfunction of the handle. In addition the Elma handle has a positioning pin. This pin, anchored in the tapped strip, precisely aligns each board within its slot, eliminating lateral forces to adjacent boards (this guarantees the functionality of the EMC gaskets and reinforces the front extrusions). A matter of course are the coding (up to 4096 possibilities) and the ESD pin for electrostatic discharge of the front panel (via an ESD clip in the card guide) as defined in the IEEE standard.

The CompactPCI Hot Swap specification asks for a switch incorporated in the handle assembly. And the VME64x specifications requires a handle with a build in locking feature. Elma has added these features to the above mentioned handle. Thus offering the user two almost identical handles for different requirements. Unique and user friendly is the locking feature:

To remove the plug-in unit first the handle has to be unlocked by pushing down the red button on the handle. The red button also activates at the same time the switch (open). The red button remains depressed. Now the plug-in unit can be removed by pushing the handle outwards. If the red button was pushed in error, push the handle inwards. When the plug-in unit is fully seated, the red button jumps up automatically thus locking the handle and activating the switch (closed).

To separate the two operations (unlocking and extraction) means security and guarantees that the handle meets completely the Hot Swap specification. According to the specification the switch has to change the state as the handle is unlocked but before any movement of the board begins. On insertion the switch should change state after the board is fully seated (physical connection is done). This locking happens automatically with the Elma handle. Only when the plug-in unit is fully and correctly inserted, will the handle be locked and the switch actuated (closed).

The Hot Swap specification highly recommends a protective cover for Hot Swap boards. The cover from Elma can be mounted without screws. It is inserted between printed board and front panel. Then the double-sided adhesive tape is pressed on the printed board through the pins of the connector. No time or money is wasted fitting screws and in addition the cover can be fixed on all 6U-, 160mm and 80mm boards even on those where holes for a protective cover are missing.

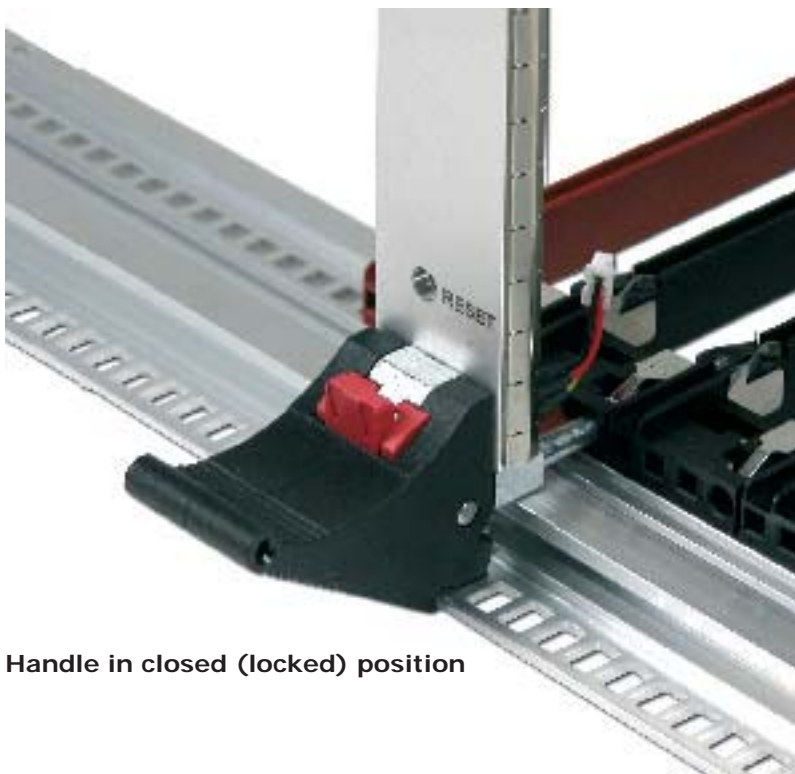

Handle in closed (locked) position

# 3: Handles

## 3.4.8 Card Holder and Coding Pins acc. to IEEE

- **Scope of delivery:**

- End piece card holder (die-cast tin, galvanized)
- Assembly material (screws M2.5 for fixing of front panel/card holder/printed board)

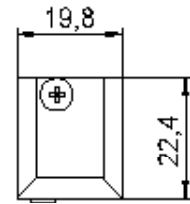
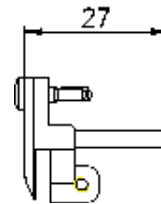

### 3.4.8.1 Card Holder/End Piece *with* ESD Pin

Description	Part-No. 1 pc.
Top	81-070
Bottom	81-071



### 3.4.8.2 Card Holder/End Piece *without* ESD Pin

Description	Part-No. 1 pc.
Top	81-070-01
Bottom	81-071-01



### 3.4.8.3 Coding Pins

- Acc. to IEC60297-3-103
- Plastic, UL94 V-0
- Can be rotated in 4 positions
- Card guides see chapter 7

Description	Part-No. 1 pc.
Grey	81-054-02
Dark red	81-054-06
Black	81-054-04

# 3: Handles



## 3.5 Injector/Ejector Handles acc. to AdvancedTCA

- Ergonomic for easy operation
- Material: steel
- With latching (hot-swap)



### 3.5.1. Classic Handle

- **Scope of delivery:**
  - 2 steel handles
  - 2 shoulder screws M2.5, Torx size T10
  - 4 + 4 washers
  - 2 latch spring clips

Description	Part-No.
2 handles	12T130



### 3.5.2 Ergonomic Handle acc. to ATCA

- Pre-assembled
- Easy assembling onto front panel and PCB
- Product still in development
- Available from end 2006, samples earlier (on request)

Description	Part-No.
	<b>1 pc.</b>
Top handle	AT-300
Bottom handle	AT-301

Please find further information on [www.elma.com](http://www.elma.com).



### 3.5.3 Microswitch for Injector/Ejector Handle

- Technical data and function see 3.4.7

Description	Part-No.
	<b>1 pc.</b>
Microswitch with pre-assembled wire cable length (25 mm)	81-088

# Application of Front Panels, Handles & Accessories



Source: Telkoor, USA