



Thermal Camera Unit (MLX90640)

SKU: U016

THERMAL is a thermal imager Unit contains a thermopile sensors named **MLX90640**. It can be used to measure the surface temperature of an object and form a thermographic image by a temperature gradient composed of different surface temperatures. The image resolution is **32 x 24**.

The MLX90640 Infrared (IR) sensor array combines high resolution and reliable operation in harsh environments, providing a cost-effective alternative to more expensive high-end thermal imaging cameras. Unlike the case of a microbolometer, the sensor does not require frequent recalibration, ensuring continuous monitoring and reducing system cost.

The field of view (FoV) option includes a standard $55^\circ \times 35^\circ$ version and a wide angle version of $110^\circ \times 75^\circ$ for distances up to 7m. This Unit is **$110^\circ \times 75^\circ$ FoV**, also known as the BAA package. The Unit communicates with the M5Core through the Grove A interface, IIC address is **0x33**

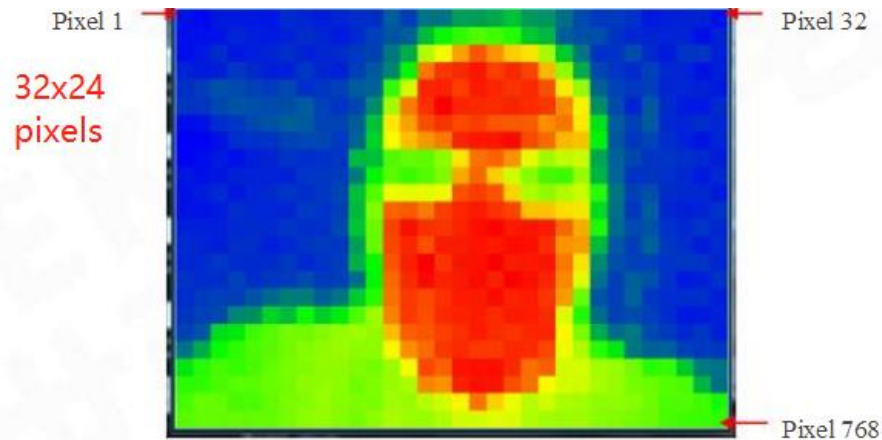

Product Features

- Operating Voltage: 3V ~ 3.6V
- Current Consumption: 23mA
- Field of View: 55°x35°
- Measurement Range: -40°C ~ 300°C
- Resolution: ±1.5°C
- Refresh Rate: 0.5Hz-64Hz
- Operating temperature: -40°C ~ 85°C
- Two Lego-compatible holes

Kit includes

- 1x THERMAL Unit
- 1x Grove Cable

Application

- High precision non-contact temperature measurements
- Intrusion / Movement detection
- Visual IR thermometers

Example

Arduino IDE

The code below is incomplete. To get complete code, please click [here](#).

```
/*
  MLX90640.ino
*/
#include <M5Stack.h>
#include <Wire.h>
#include "MLX90640_API.h"
#include "MLX90640_I2C_Driver.h"

// declaration
uint16_t eeMLX90640[832]; // 32 * 24 = 768
int SetRefreshRate;

// initialization
/* load system parameter */
MLX90640_DumpEE(MLX90640_address, eeMLX90640);
/* load extraction parameter */
MLX90640_ExtractParameters(eeMLX90640, &mlx90640);
SetRefreshRate = MLX90640_SetRefreshRate(0x33, 0x05);
```

```

M5.Lcd.fillScreen(TFT_BLACK);
infodisplay();

// display heat map
M5.update();
infodisplay();
interpolate_image(reversePixels,ROWS,COLS,dest_2d,\
INTERPOLATED_ROWS,INTERPOLATED_COLS);

```



Schematic

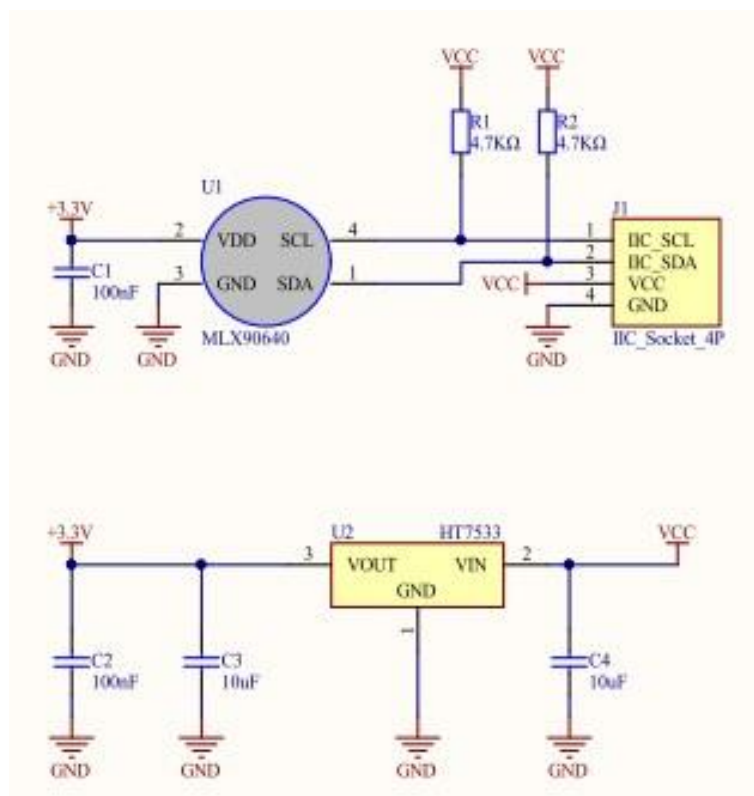

PinMap

M5Core (GROVE A)	GPIO22	GPIO21	5V	GND
THERMAL Unit	SCL	SDA	5V	GND



<https://m5stack.com/collections/m5-unit/products/thermal-camera/12-99-19>