

# SPECIFICATION

## PATENT PENDING

- Part No. : **WDMP.2458.A**
- Description : 5dBi Embedded Dual-Band WiFi Circular Polarized  
50mm Patch Antenna With SMA(F) Connector
- Features : High efficiency Dual-band WiFi 2.4GHz / 5~6GHz  
RHCP  
5dBi + at 2.4GHz / 7dBi + at 5~6GHz  
Military grade dielectrics & low loss substrates.  
50mm x 50mm x 16.57 mm ( with connector )  
50 x 50 x 7.07 mm (without connector )  
Screw mount with SMA(F) ST connector  
RoHS Compliant

Photo:



Front



Back

## 1. Introduction

The WDMP.2458.A antenna with SMA(F) connector is a circular polarized dual-band Wi-Fi antenna which consists of an advanced composite dielectric structure, providing better performance at greater distance and a broader band frequency range in the smallest package in the market.

Using military grade substrates, the WDMP.2458.A is aimed at unmanned systems, such as unmanned aerial/ground vehicles (UAVs/UGVs), robotics, and ground controllers/stations, applicable in different sectors from civilian, law enforcement, to defence.

Taking advantage of substrates of low dielectric constant and low dissipation factor, the WDMP.2458.A uses glass microfiber reinforced PTFE substrates to minimize signal transmission loss in order to achieve high efficiency. It performs with high efficiencies at WiFi bands from 2400~2500MHz and 5150~5850MHz of 74% and 67%, and with peak gains of 5.5 dBi and 7.3 dBi respectively.

Using circular polarized signals means the link is more stable for devices where the direction of orientation is unknown or where multipath is an issue.

The WDMP.2458.A's low profile design, equipped with a SMA(F) connector, is easy to install inside a housing or directly onto a PCB mainboard. It has four thru-holes at the patch corners, allowing users to fix the antenna with screws. The antenna has passed ISO 16750 high/low-temperature test and random vibration reliability testing.

Many module manufacturers specify peak gain limits for any antennas that are to be connected to that module. Those peak gain limits are based on free-space conditions. In practice, the peak gain of an antenna tested in free-space can degrade by at least 1 or 2dBi when put inside a device. So ideally you should go for a slightly higher peak gain antenna than mentioned on the module specification to compensate for this effect, giving you better performance.

Upon testing of any of our antennas with your device and a selection of appropriate layout, integration technique, or cable, Taoglas can make sure any of our antennas' peak gain will be below the peak gain limits. Taoglas can then issue a specification and/or report for the selected antenna in your device that will clearly show it complying with the peak gain limits, so you can be assured you are meeting regulatory requirements for that module.

For example, a module manufacturer may state that the antenna must have less than 2dBi peak gain, but you don't need to select an embedded antenna that has a peak gain of less than 2dBi in free-space. This will give you a less optimized solution. In that case it will be better to go for a slightly higher free-space peak gain of 3dBi or more if available. Once that antenna gets integrated into your device, performance will degrade below this 2dBi peak gain due to the effects of GND plane, surrounding components, and device housing. If you want to be absolutely sure, contact Taoglas and we will test. Choosing a Taoglas antenna with a higher peak gain than what is specified by the module manufacturer and enlisting our help will ensure you are getting the best performance possible without exceeding the peak gain limits.

## 2. Specification

ELECTRICAL		
Frequency Range (MHz)	2400-2500	5150-5850
Return Loss (dB)	< -7	< -6
Efficiency (%)	74.19	66.97
Peak Gain (dBi)	5.5	7.3
Polarization	RHCP	
Axial Ratio	Min. 1.75	Min. 1
Impedance (Ohm)	50 Ω	
Input Power	10W	
MECHANICAL		
Dimension (mm)	50 x 50 x 7.07 (without connector) 50 x 50 x 16.57 (with connector )	
Antenna Patch Material	PTFE composites	
Connector	SMA(F) ST	
Weight (g)	32.5	
ENVIRONMENTAL		
Operation Temperature	-40°C ~ + 85°C	
Storage Temperature	-40°C ~ + 85°C	

## 3. Antenna Characteristics

### 3.1 Test set-up

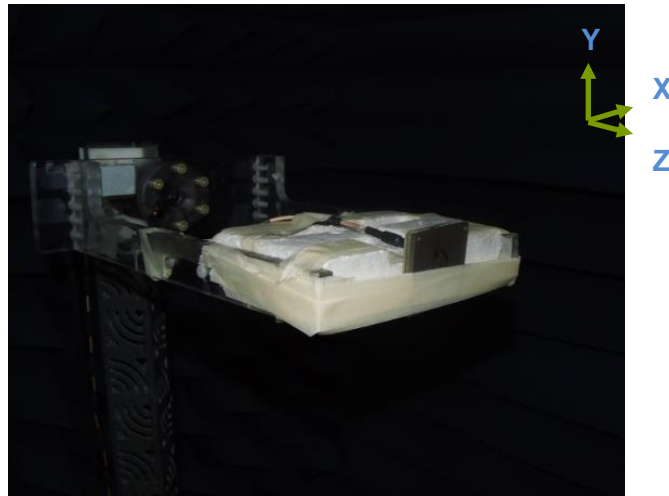

**Figure 1.** Peak gain, efficiency and radiation pattern measurements

### 3.2 Return Loss

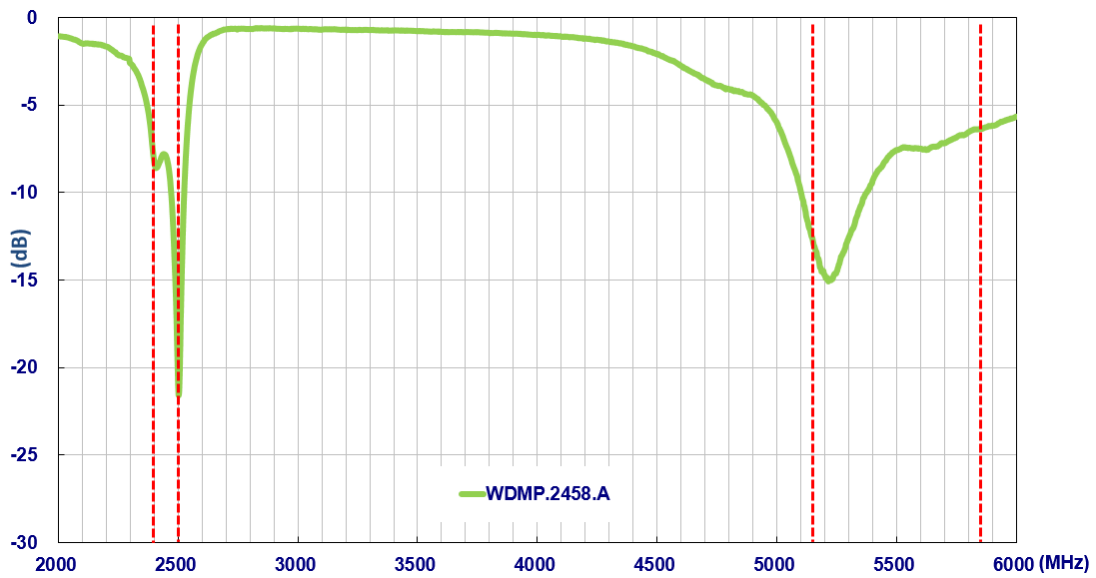

Figure 2. Return Loss

### 3.3 Efficiency

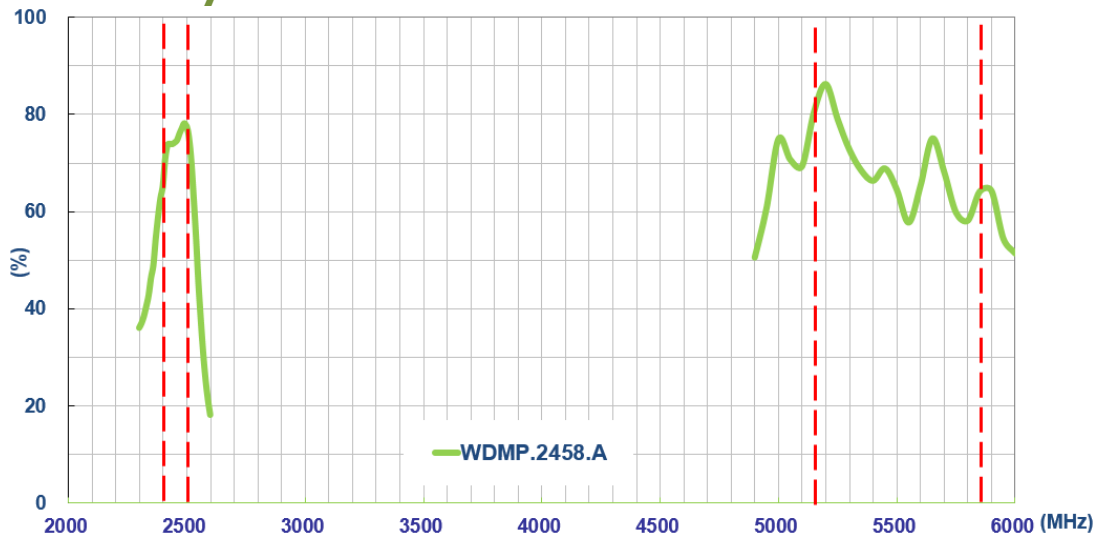

Figure 3. Efficiency

### 3.4 Peak Gain

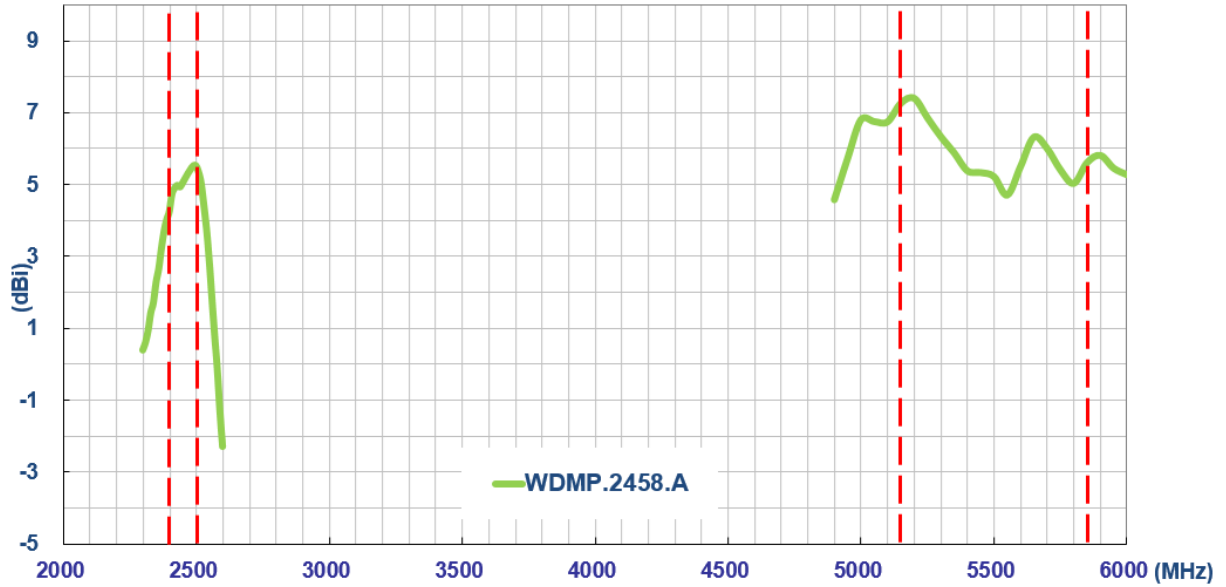

Figure 4. Peak Gain.

### 3.5 Average Gain

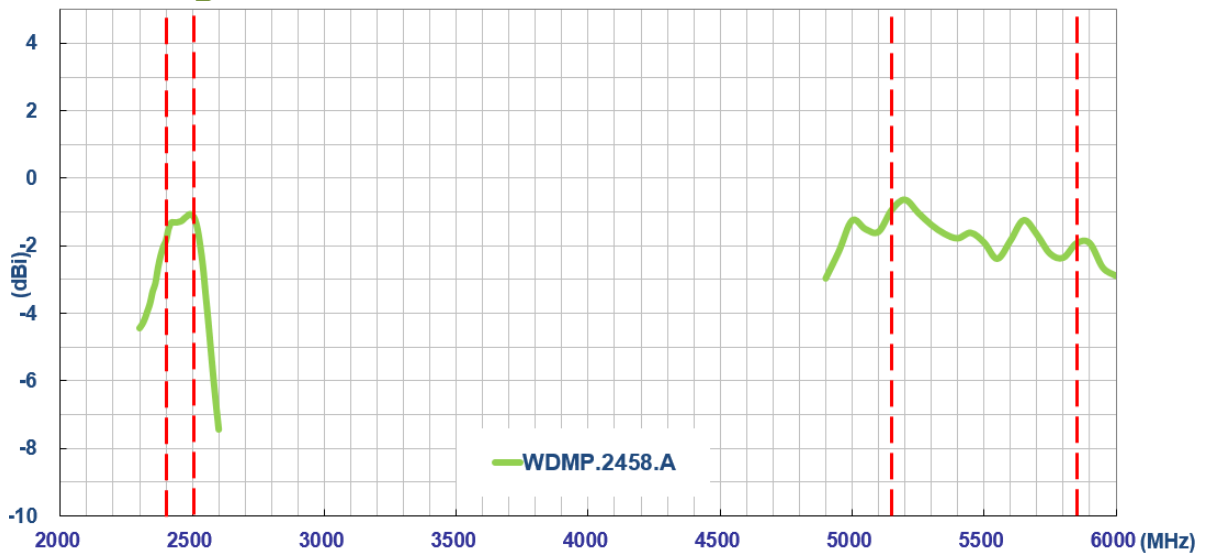
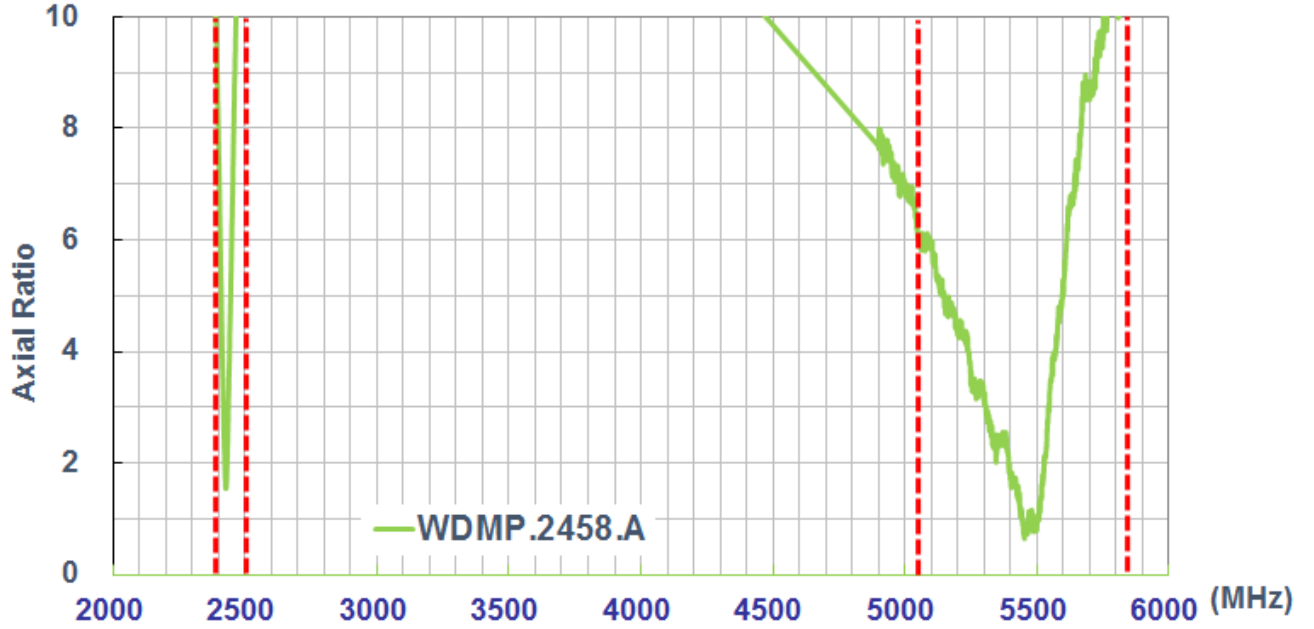

Figure 5. Average Gain

### 3.6 Axial Ratio



*Figure 6. Axial Ratio*



### 3.7 Radiation Patterns

#### 2D Patterns

XY-Plane

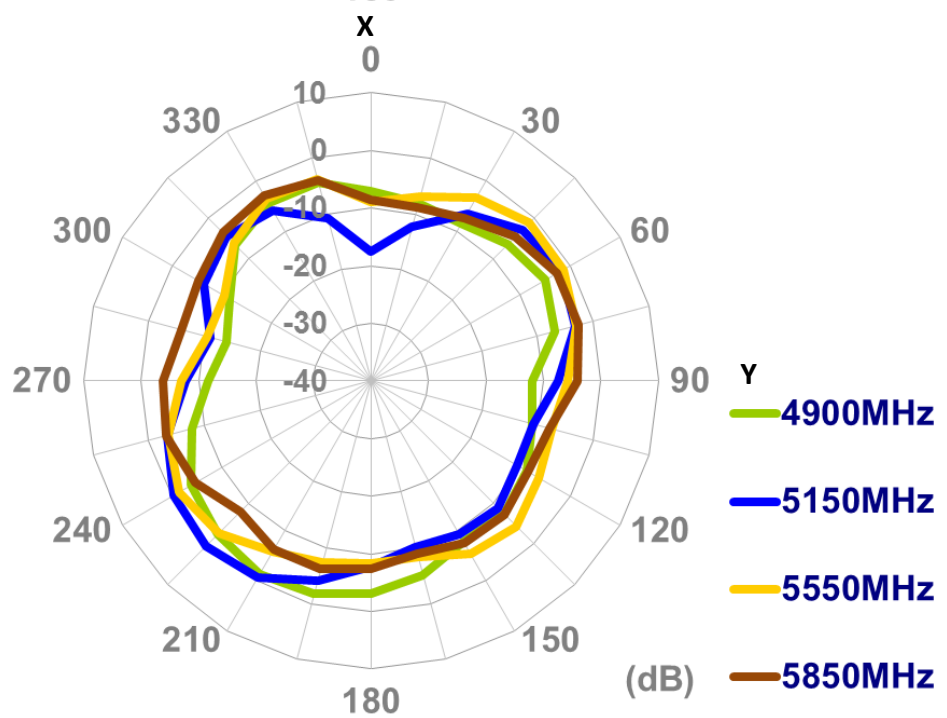
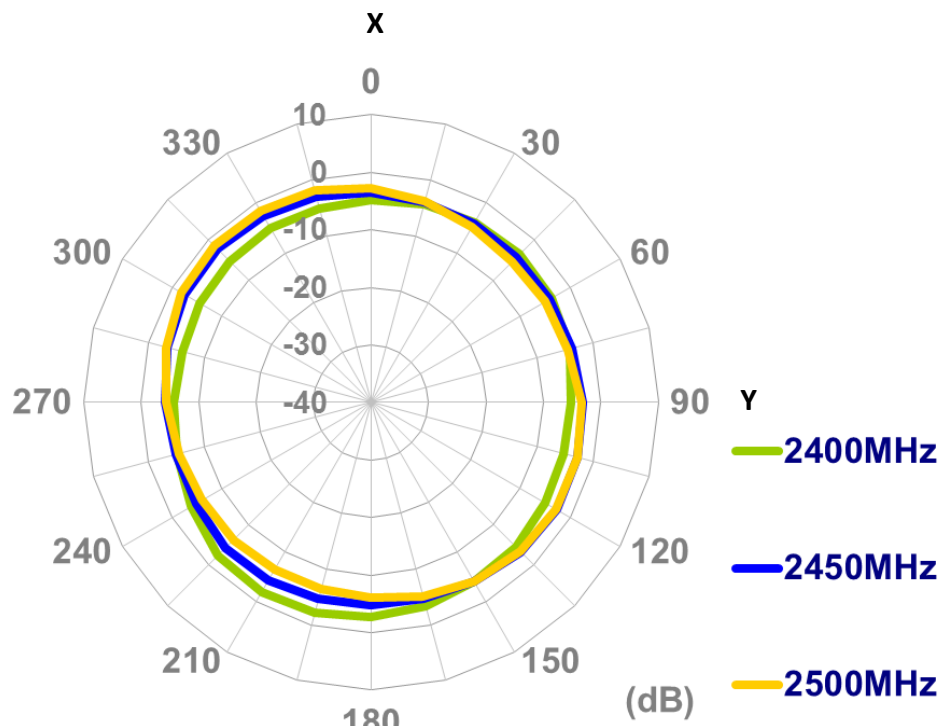



**TAOGLAS**<sup>®</sup>

XZ-Plane

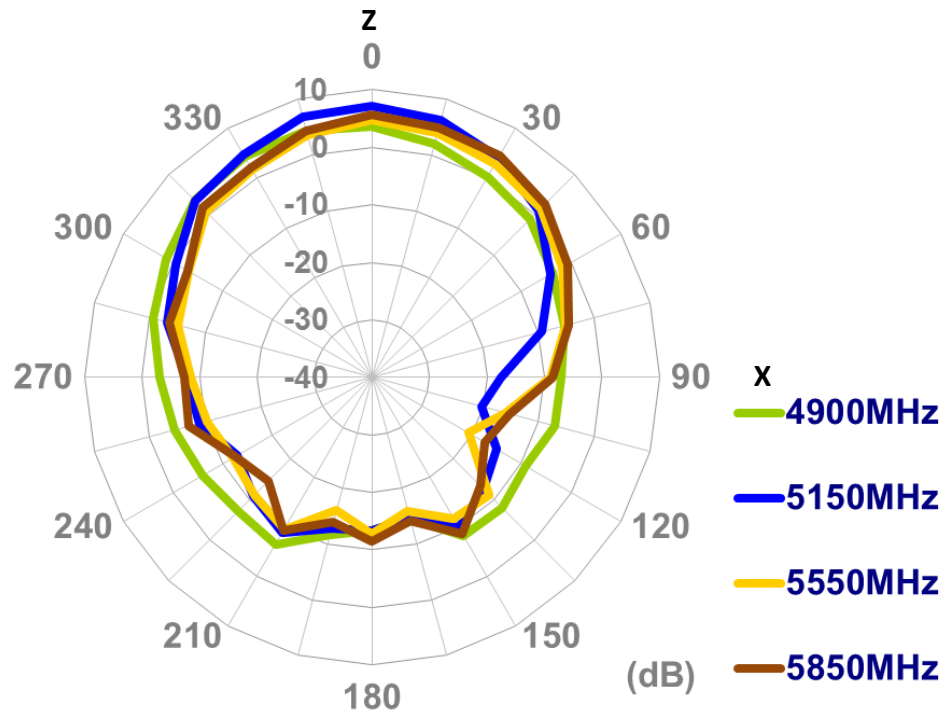
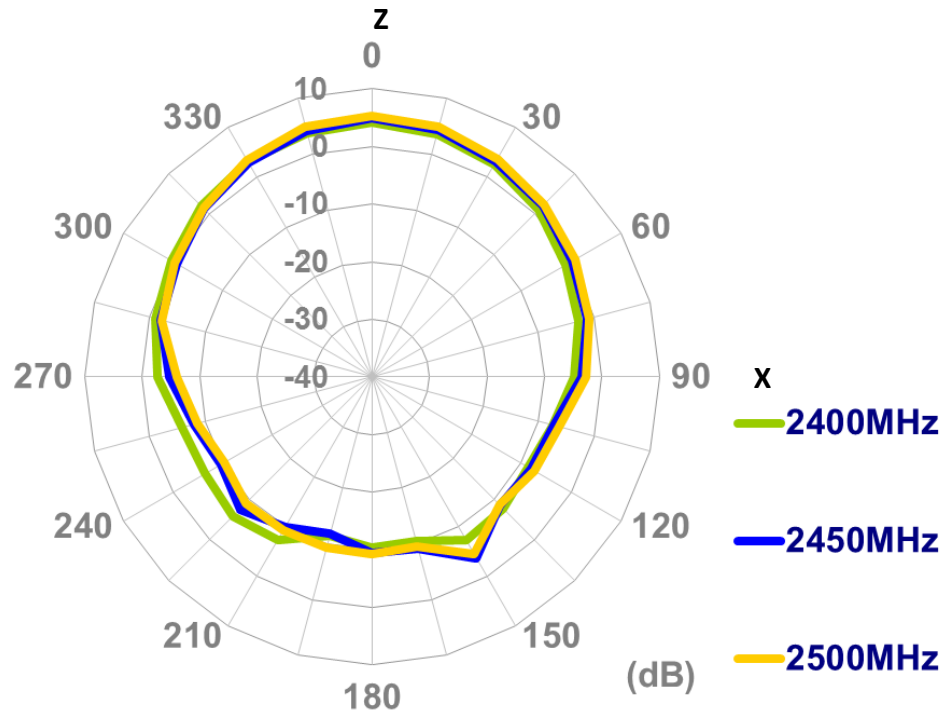



**TAOGLAS**<sup>®</sup>

YZ-Plane

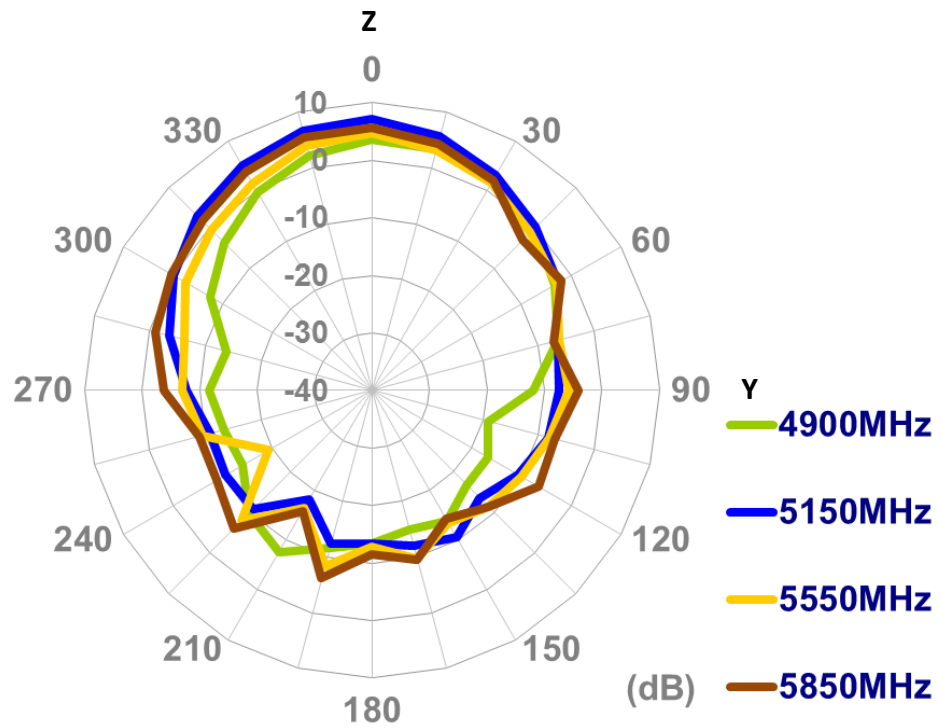
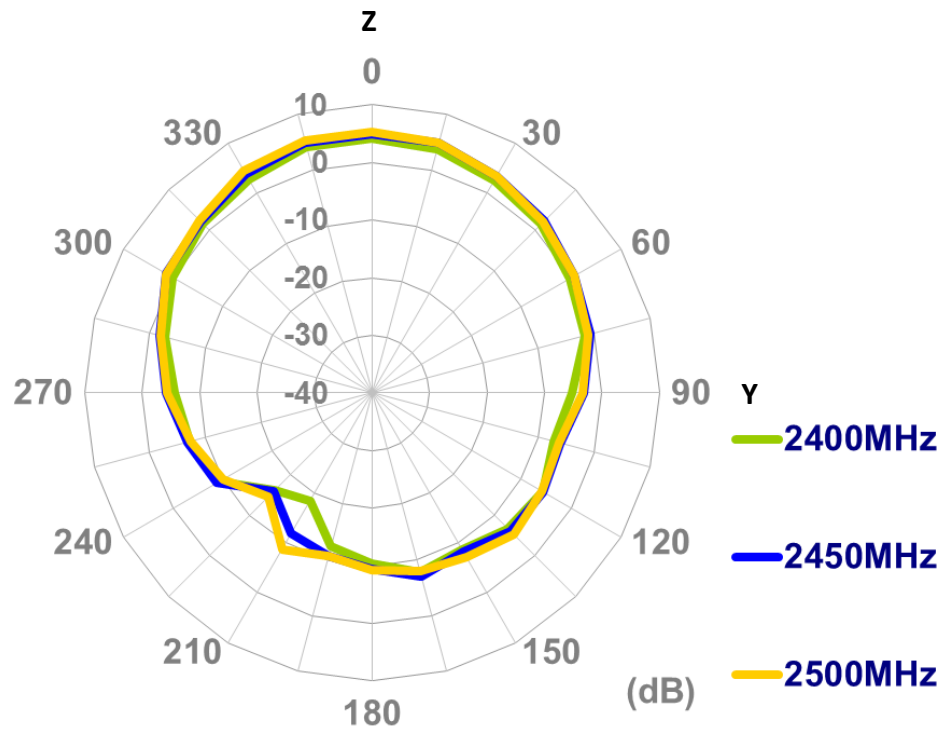

3D Patterns

Azimuth = 0.0  
Elevation = -15.0  
Roll = -45.0

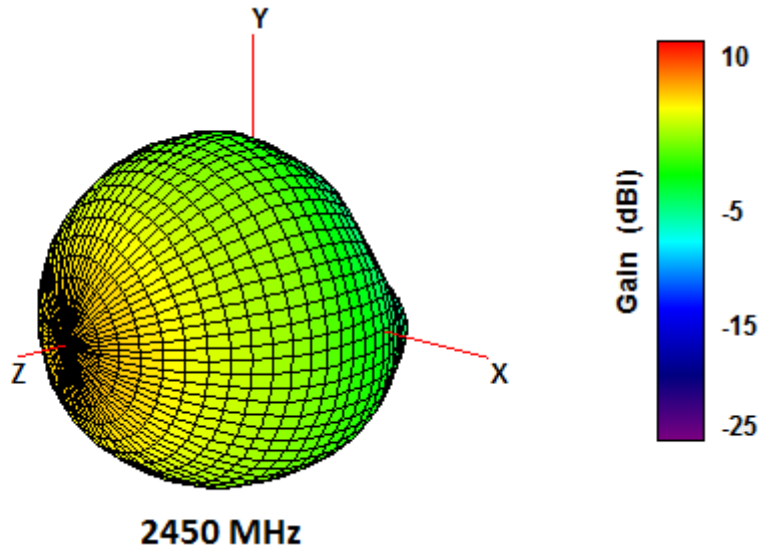

**Figure 7.** 3D Radiation Pattern at 2450 MHz

Azimuth = 0.0  
Elevation = -15.0  
Roll = -45.0

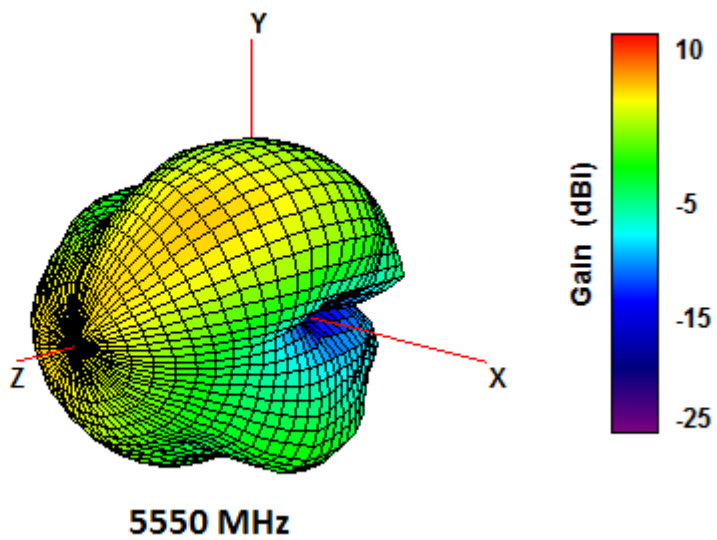

**Figure 8.** 3D Radiation Pattern at 5550 MHz

## 4. Drawing (unit: mm)

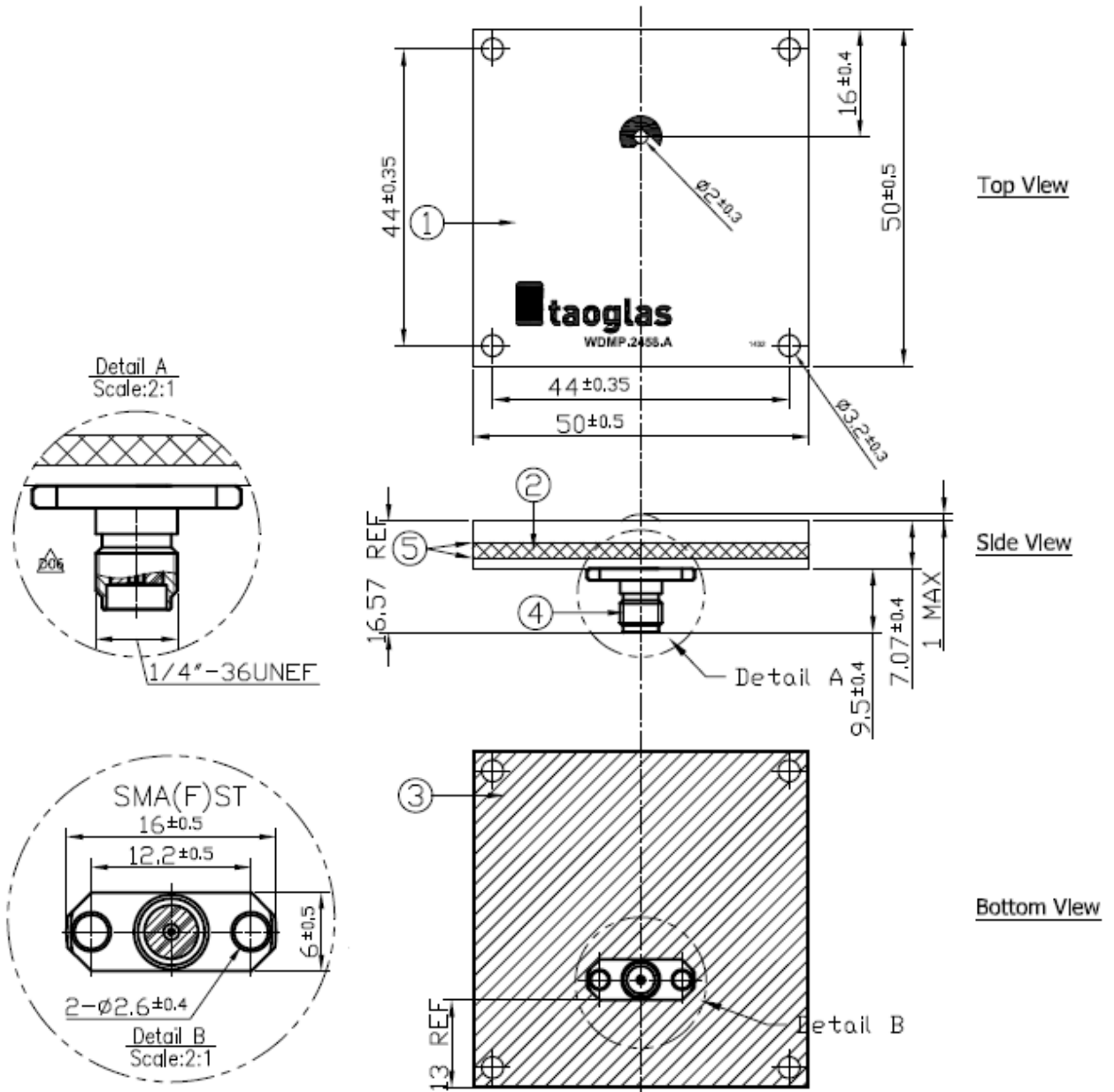

	Name	Material	Finish	QTY
1	WDMP.2458 Top_PCB	PTFE composites	Dark Gray	1
2	WDMP.2458 Middle_PCB	Composite	Black	1
3	WDMP.2458 Bottom_PCB	PTFE composites	Light Grey	1
4	SMA(F) ST For PCB	Brass	Gold	1
5	WDMP.2458 Double sided Adhesive	3M Adhesive	N/A	2

**Figure 9.** Dimensions and Drawing

## 5. Packaging

### WDMP.2458.A

#### Packaging Specifications

25 pcs WDMP.2458.A per tray  
Each tray in vacumed PE bag  
Tray Dimensions - 340\*340\*27mm  
Weight - .91Kg per tray

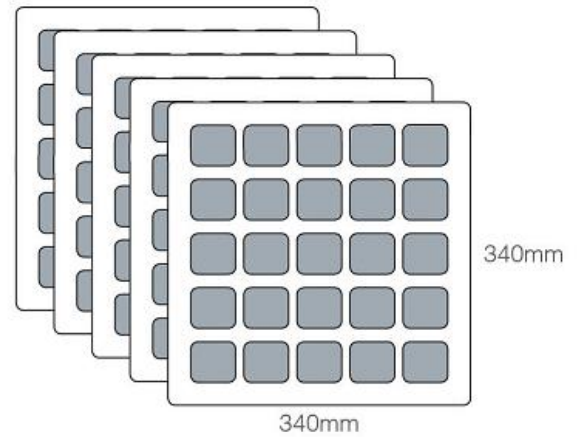



**TAOGLAS**®

10 Trays per Carton - 250 pcs  
Carton Dimensions - 360\*360\*310mm  
Weight - 9.93Kg

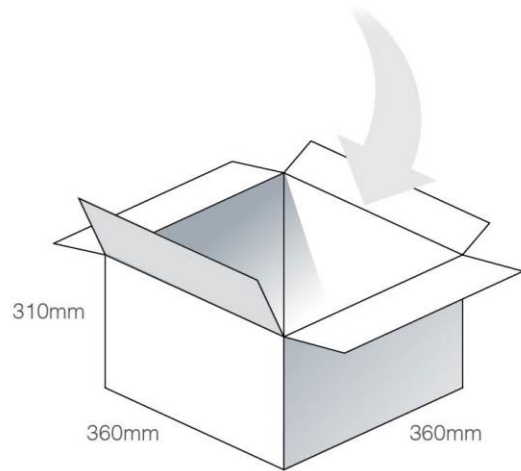

Pallet Dimensions 1100\*1100\*1370mm  
36 Cartons per Pallet  
9 Cartons per layer  
4 Layers

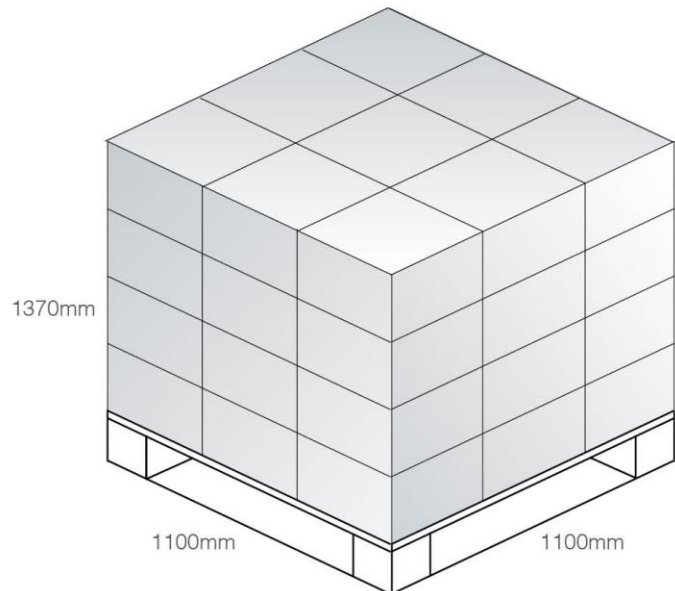

**Figure 10.** Package

## 6. Installation Instructions

There might be situations where the WDMP.2458.A needs to be sit firmly on the device board, either a plastic or a metal board. The patch provides four screw holes for this purpose.

This section illustrates the type of screw and screw/connector holes dimension should be considered for installation.

**Screw type :** Non-conductive M3 screw

**Nut type :** Non-conductive HEX M3 nut

**On-board screw holes dimension :**  $\varnothing$  3.2mm

**On-board connector holes dimension :** 18 x 8 mm

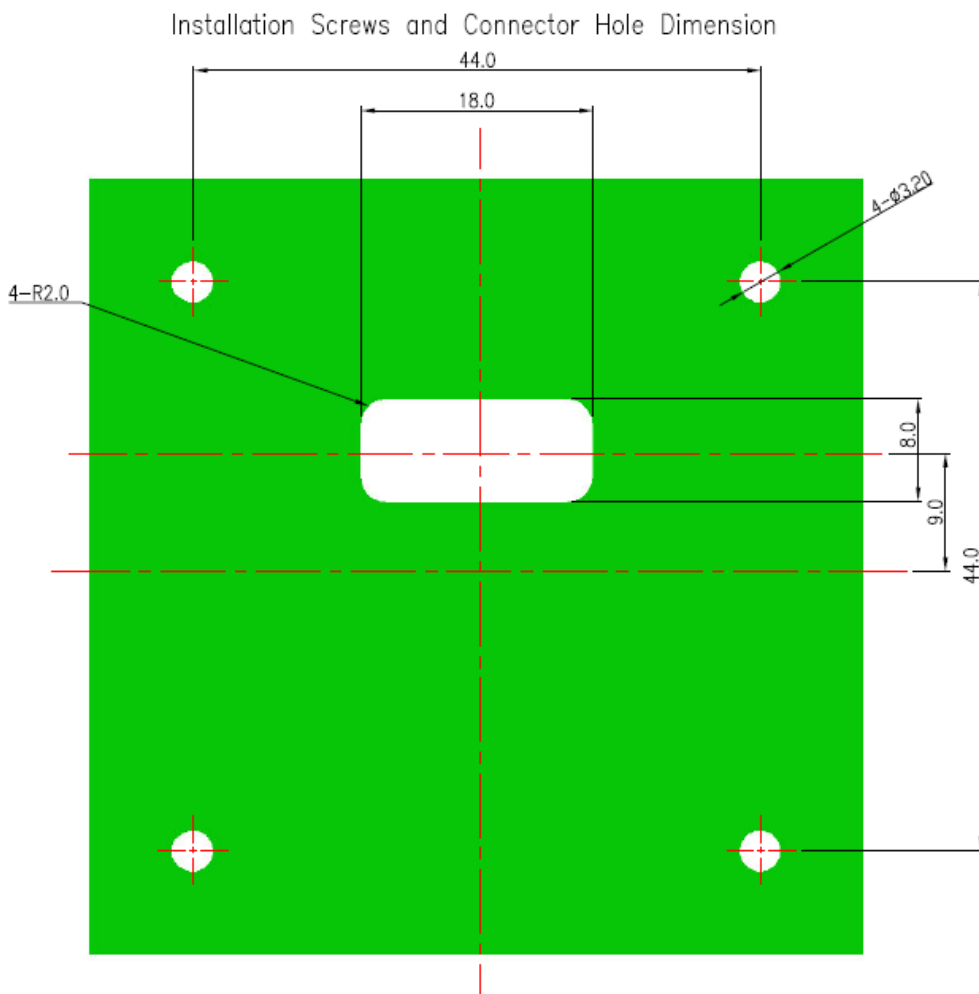
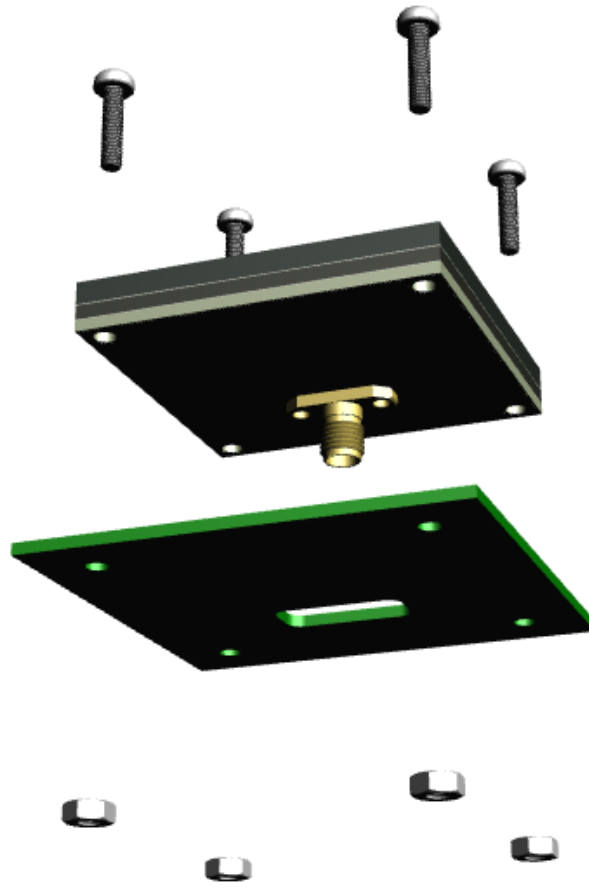

Figure 1. Dimensions of screw holes and connector hole on implemented board





**Figure 2. Exploded view of screw installation**

Screw Length  $\geq 7.07 + X + 2.5$  (M3 Nut Thickness)

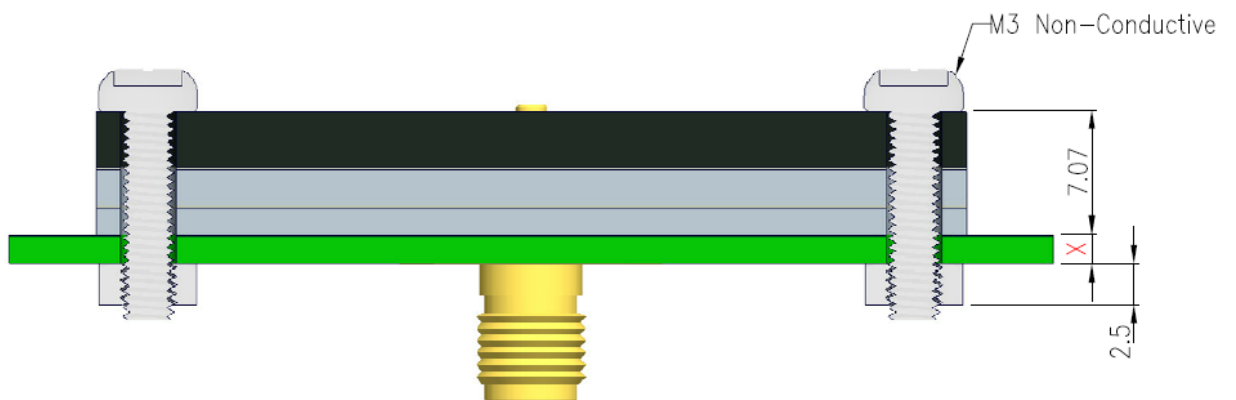

**Figure 3. Screw length calculation. X = implemented board thickness**

## 7. Application Note

The WDMP.2458.A has the same performance either in free space or on ground plane.

Following charts show the return loss, efficiency and peak gain in free space, on 10x10, 20x20 and 30x30cm ground plane.

### 7.1 Return loss

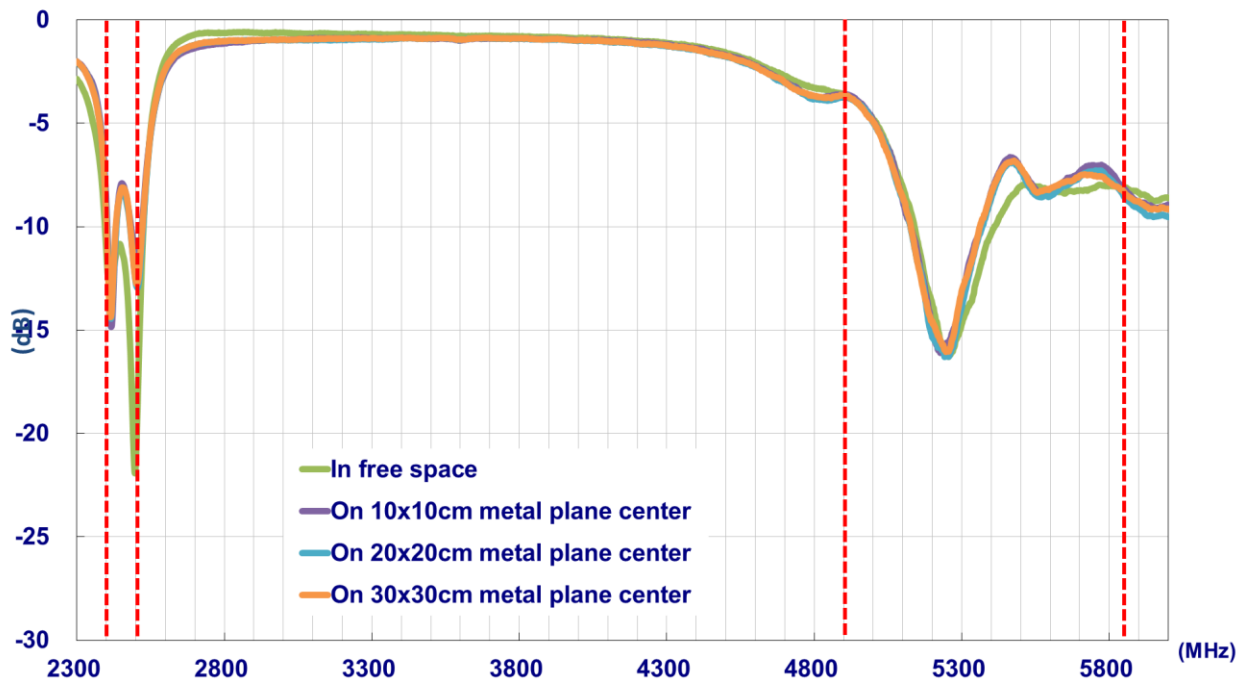

## 7.2 Efficiency

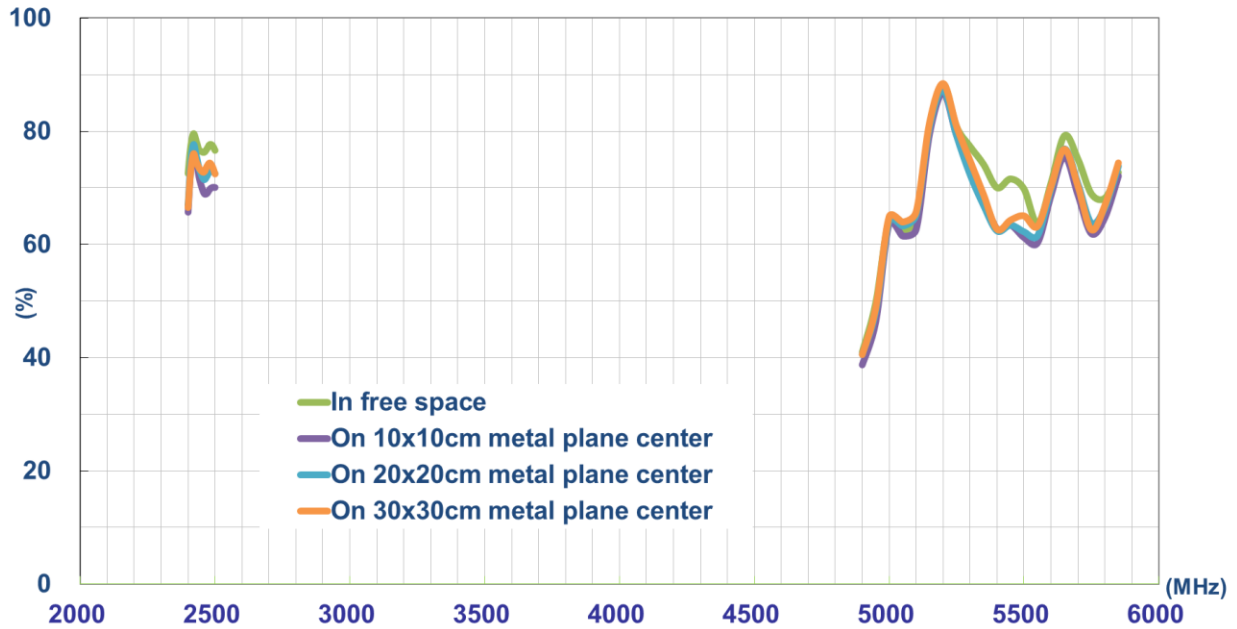

## 7.3 Peak Gain

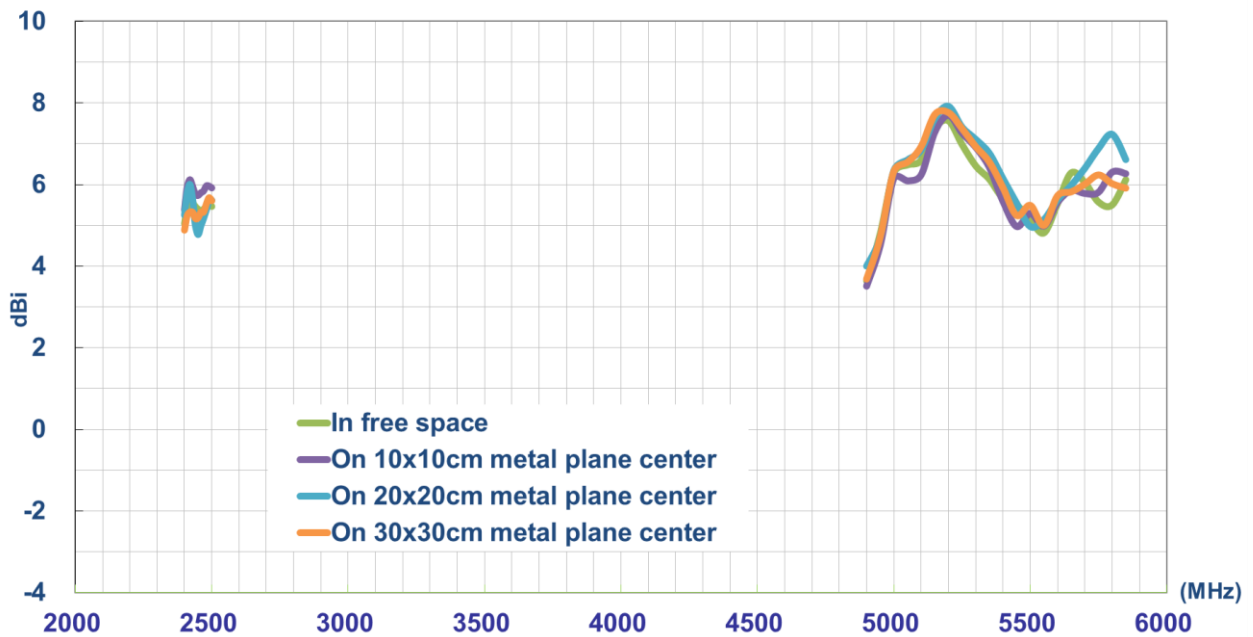

# Mouser Electronics

Authorized Distributor

Click to View Pricing, Inventory, Delivery & Lifecycle Information:

Taoglas:

[WDMP.2458.A](#)