

MEMS motion sensor: ultra-compact two-axis gyroscope for optical image stabilization

Datasheet - production data

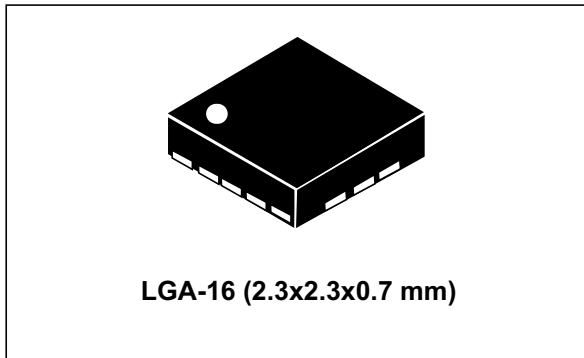

Features

- ± 100 dps / ± 200 dps full-scale range
- Wide supply voltage range: 1.71 V to 3.6 V
- Low-voltage compatible IOs
- 3- and 4-wire SPI digital interface
- Embedded temperature sensor
- Embedded self-test
- Integrated low- and high-pass filters with user-selectable bandwidth
- Power-down and sleep modes for smart power saving
- ECOPACK[®], RoHS and “Green” compliant

Applications

- Optical image stabilization

Description

The L2G2IS is a two-axis MEMS gyroscope for optical image stabilization applications.

It includes a sensing element and an IC interface capable of providing the measured angular rate to the application through an SPI digital interface.

The unique sensing element is manufactured using a dedicated micromachining process developed by STMicroelectronics to produce inertial sensors and actuators on silicon wafers.

The IC interface is manufactured using a CMOS process that allows a high level of integration to design a dedicated circuit which is trimmed to better match the characteristics of the sensing element.

The L2G2IS is available in a plastic land grid array (LGA) package and can operate over a temperature range of -40 °C to $+85$ °C.

Table 1. Device summary

| Order code | Temperature range (°C) | Package | Packing |
|------------|------------------------|-------------------------|---------------|
| L2G2IS | -40 to +85 | LGA-16 (2.3x2.3x0.7 mm) | Tray |
| L2G2ISTR | -40 to +85 | LGA-16 (2.3x2.3x0.7 mm) | Tape and reel |

Contents

- 1 Block diagram and pin description 6**
 - 1.1 System block diagram 6
 - 1.2 Pin description 7

- 2 Terminology & functionality 8**
 - 2.1 Sensitivity 8
 - 2.2 Zero-rate level 8
 - 2.3 Data-ready interrupt and synchronous reading 8
 - 2.4 Temperature sensor 8

- 3 Mechanical and electrical characteristics 9**
 - 3.1 Mechanical characteristics 9
 - 3.2 Electrical characteristics 10
 - 3.3 Temperature sensor characteristics 11
 - 3.4 SPI - serial peripheral interface 12
 - 3.5 Absolute maximum ratings 13

- 4 Application hints 14**

- 5 Digital interfaces 15**
 - 5.1 SPI bus interface 15
 - 5.1.1 SPI read 16
 - 5.1.2 SPI write 16
 - 5.1.3 SPI read in 3-wire mode 17

- 6 Output register mapping 18**

- 7 Register description 19**
 - 7.1 WHO_AM_I (00h) 19
 - 7.2 TEMP_OUT_L (01h), TEMP_OUT_H (02h) 19
 - 7.3 OUT_X_L (03h), OUT_X_H (04h) 19
 - 7.4 OUT_Y_L (05h), OUT_Y_H (06h) 19
 - 7.5 STATUS_REG (09h) 19

| | | |
|----------|----------------------------------|-----------|
| 7.6 | CTRL_REG1 (0Bh) | 20 |
| 7.7 | CTRL_REG2 (0Ch) | 21 |
| 7.8 | CTRL_REG3 (0Dh) | 21 |
| 7.9 | ORIENT_CONFIG (10h) | 22 |
| 7.10 | OFF_X (11h) | 22 |
| 7.11 | OFF_Y(12h) | 23 |
| 7.12 | CTRL_REG4 (1Fh) | 23 |
| 8 | Package information | 24 |
| 8.1 | Soldering information | 24 |
| 8.2 | LGA-16 package | 24 |
| 9 | Revision history | 25 |

List of tables

| | | |
|-----------|---|----|
| Table 1. | Device summary | 1 |
| Table 2. | Pin description | 6 |
| Table 3. | Mechanical characteristics | 8 |
| Table 4. | Electrical characteristics | 9 |
| Table 5. | Temperature sensor characteristics | 10 |
| Table 6. | SPI slave timing values. | 11 |
| Table 7. | Absolute maximum ratings | 12 |
| Table 8. | External component values. | 13 |
| Table 9. | Serial interface pin description | 14 |
| Table 10. | Register address map. | 17 |
| Table 11. | WHO_AM_I register | 18 |
| Table 12. | TEMP_OUT_L register | 18 |
| Table 13. | TEMP_OUT_H register. | 18 |
| Table 14. | TEMP_OUT resolution | 18 |
| Table 15. | STATUS_REG register. | 18 |
| Table 16. | STATUS_REG description | 19 |
| Table 17. | CTRL_REG1 register | 19 |
| Table 18. | CTRL_REG1 description | 19 |
| Table 19. | Operating mode selection. | 20 |
| Table 20. | CTRL_REG2 register | 20 |
| Table 21. | CTRL_REG2 description | 20 |
| Table 22. | CTRL_REG3 register | 20 |
| Table 23. | CTRL_REG3 description | 20 |
| Table 24. | Low-pass filter cutoff frequency selection. | 21 |
| Table 25. | ORIENT_CONFIG register | 21 |
| Table 26. | ORIENT_CONFIG description | 21 |
| Table 27. | OFF_X register | 21 |
| Table 28. | OFF_X description | 21 |
| Table 29. | OFF_Y register | 22 |
| Table 30. | OFF_Y description | 22 |
| Table 31. | CTRL_REG4 register | 22 |
| Table 32. | CTRL_REG4 description | 22 |
| Table 33. | High-pass filter cutoff frequency selection | 22 |
| Table 34. | LGA-16 package outer dimensions. | 23 |
| Table 35. | Document revision history. | 24 |

List of figures

| | | |
|------------|---|----|
| Figure 1. | Block diagram | 6 |
| Figure 2. | Pin connections | 7 |
| Figure 3. | SPI slave timing diagram | 12 |
| Figure 4. | L2G2IS electrical connections and external components | 14 |
| Figure 5. | SPI read protocol | 16 |
| Figure 6. | SPI write protocol | 16 |
| Figure 7. | Multiple byte SPI write protocol (2-byte example). | 17 |
| Figure 8. | SPI read protocol in 3-wire mode | 17 |
| Figure 9. | LPF chain block diagram | 22 |
| Figure 10. | LGA-16 package outline and dimensions | 24 |

1 Block diagram and pin description

1.1 System block diagram

Figure 1. Block diagram

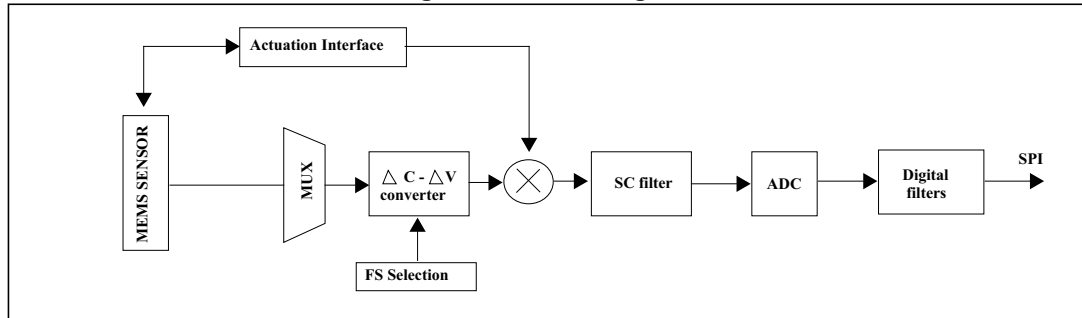

1.2 Pin description

Figure 2. Pin connections

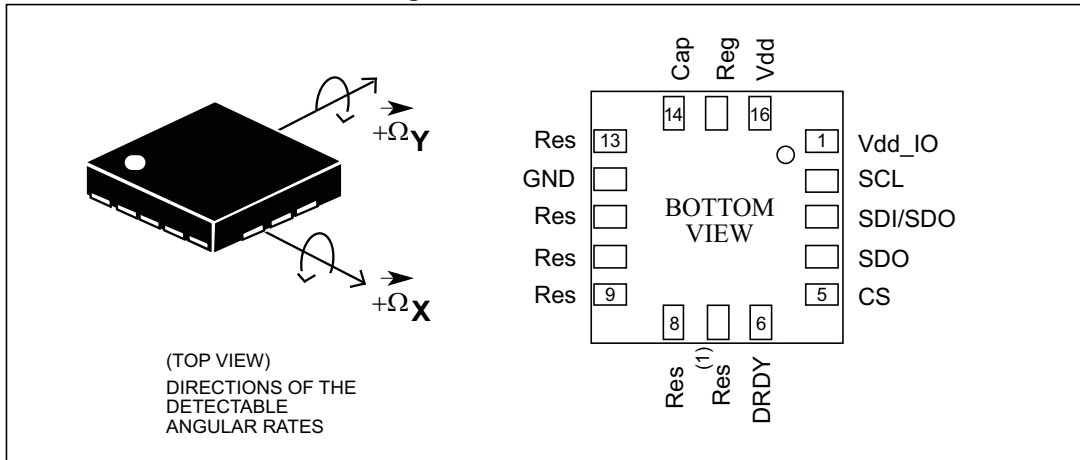

1. Leave pin electrically unconnected and soldered to PCB.

Table 2. Pin description

| Pin# | Name | Function |
|------|--------------------|--|
| 1 | Vdd_IO | Power supply for I/O pins |
| 2 | SCL | Clock line for SPI interface |
| 3 | SDI/SDO | Serial data input (SDI) 3-wire interface serial data output (SDO) |
| 4 | SDO | Serial data output (SDO) |
| 5 | CS | Chip-select line |
| 6 | DRDY | Data ready signal |
| 7 | Res ⁽¹⁾ | Leave unconnected |
| 8 | Res | Connect to GND |
| 9 | Res | Connect to GND |
| 10 | Res | Connect to GND |
| 11 | Res | Connect to GND |
| 12 | GND | 0 V power supply |
| 13 | Res | Connect to GND |
| 14 | Cap | Capacitance connection pin for internal charge pump |
| 15 | Reg | Capacitance connection pin for internal regulator |
| 16 | Vdd | Power supply |

1. Leave pin electrically unconnected and soldered to PCB.

2 Terminology & functionality

2.1 Sensitivity

An angular rate gyroscope is a device that produces a positive-going digital output for counterclockwise rotation around the sensitive axis considered. Sensitivity describes the gain of the sensor and can be determined by applying a defined angular velocity to it. This value changes very little over temperature and time.

2.2 Zero-rate level

The zero-rate level describes the actual output signal if there is no angular rate present. The zero-rate level of highly accurate MEMS sensors is, to some extent, a result of stress to the sensor and therefore the zero-rate level can slightly change after mounting the sensor on a printed circuit board or after exposing it to extensive mechanical stress. This value changes very little over temperature and time.

2.3 Data-ready interrupt and synchronous reading

On the L2G2IS the angular rate data can be retrieved using a synchronous read. To perform a synchronous read, [CTRL_REG3 \(0Dh\)](#) (DRDY_EN) has to be set to '1' in order to enable the data-ready interrupt on the DRDY pin (refer to [Figure 4](#)). To properly perform a synchronous read, the angular rate data have to be read every time the DRDY pin goes high.

The DRDY signal can be latched (default condition) or pulsed if the [CTRL_REG1 \(0Bh\)](#) (P_DRDY) is set to '1'. When a latched condition is selected, the interrupt goes low when the high part of one of the output channels is read (OUT_X_H (04h) or OUT_Y_H (06h)) and returns high when new data is generated. When a pulsed condition is selected, the interrupt behavior is independent from the reading operations and remains high for 75 µsec every time new data is generated. The DRDY pin is set by default as push-pull output, but it can be configured as open-drain output by setting [CTRL_REG3 \(0Dh\)](#) (PP_OD) to '1'.

2.4 Temperature sensor

The temperature data can be retrieved from the [TEMP_OUT_L \(01h\)](#), [TEMP_OUT_H \(02h\)](#) register, as two's complement data in 12-bit format left-justified. The output of the temperature sensor is 0 at 25 °C.

3 Mechanical and electrical characteristics

3.1 Mechanical characteristics

V_{dd} = 2.4 V and T = 25 °C unless otherwise noted^(a).

Table 3. Mechanical characteristics

| Symbol | Parameter | Test condition | Min. | Typ. ⁽¹⁾ | Max. | Unit |
|--------|-----------------------------------|-------------------------------|------|---------------------|------|-----------|
| FS | Measurement range | | | ±100 | | dps |
| | | | | ±200 | | |
| So | Sensitivity | FS = ±100 dps | | 262 | | LSb/dps |
| | | FS = ±200 dps | | 131 | | |
| DVoff | Digital zero-rate level | | | ±5 | | dps |
| Rn | Rate noise density ⁽²⁾ | 0 - 20 Hz bandwidth | | 0.006 | | dps/(√Hz) |
| PhDI | Phase delay ⁽³⁾ | At 20 Hz (280 Hz BW selected) | | 7 | | deg |
| ODR | Digital output data rate | | | 9.09 | | kHz |
| Top | Operating temperature range | | -40 | | +85 | °C |

1. Typical specifications are not guaranteed.
2. Guaranteed by design.
3. Refer to [Figure 9: LPF chain block diagram](#) and [Table 24: Low-pass filter cutoff frequency selection](#).

a. The product is factory calibrated at 2.4 V. The operational power supply range is specified in [Table 4](#).

3.2 Electrical characteristics

@ Vdd = 2.4 V, T = 25 °C unless otherwise noted^(b).

Table 4. Electrical characteristics

| Symbol | Parameter | Test condition | Min. | Typ. ⁽¹⁾ | Max. | Unit |
|--------|---|----------------|------------|---------------------|------------|------|
| Vdd | Supply voltage | | 1.71 | 2.4 | 3.6 | V |
| Vdd_IO | I/O pins supply voltage ⁽²⁾ | | 1.71 | | Vdd | V |
| Idd | Supply current in normal mode | | | 3.8 | | mA |
| IddSL | Supply current in sleep mode ⁽³⁾ | | | 1.85 | | mA |
| IddPdn | Supply current in power-down mode | | | | 20 | μA |
| IcapIO | I/O pad driving current capability | | | | 4 | mA |
| VIH | Digital high-level input voltage | | 0.8*Vdd_IO | | | V |
| VIL | Digital low-level input voltage | | | | 0.2*Vdd_IO | V |
| Top | Operating temperature range | | -40 | | +85 | °C |

1. Typical specifications are not guaranteed.
2. It is possible to remove Vdd maintaining Vdd_IO without blocking the communication busses, in this condition the measurement chain is powered off.
3. Sleep mode introduces a faster turn-on time relative to power-down mode.

b. The product is factory calibrated at 2.4 V.

3.3 Temperature sensor characteristics

@ AVdd = 2.4 V, T = 25 °C unless otherwise noted^(c).

Table 5. Temperature sensor characteristics

| Symbol | Parameter | Test condition | Min. | Typ. ⁽¹⁾ | Max. | Unit |
|--------|--|----------------|------|---------------------|------|----------|
| TSDr | Temperature sensor output change vs. temperature | | | 0.0625 | | °C/digit |
| TODR | Temperature refresh rate | | | 70 | | Hz |
| TACC | Temperature absolute accuracy ⁽²⁾ | | | ±4 | | °C |
| Top | Operating temperature range | | -40 | | +85 | °C |

1. Typical specifications are not guaranteed.
2. The output of the temperature sensor is 0 at 25 °C. Refer to [Section 2.4: Temperature sensor](#) on how to read the temperature sensor output data.

c. The product is factory calibrated at 2.4 V.

3.4 SPI - serial peripheral interface

Subject to general operating conditions for Vdd and Top.

Table 6. SPI slave timing values

| Symbol | Parameter | Value ⁽¹⁾ | | Unit |
|---------------|-------------------------|----------------------|-----|------|
| | | Min | Max | |
| $t_{c(SCL)}$ | SPI clock cycle | 100 | | ns |
| $f_{c(SCL)}$ | SPI clock frequency | | 10 | MHz |
| $t_{su(CS)}$ | CS setup time | 5 | | ns |
| $t_h(CS)$ | CS hold time | 8 | | |
| $t_{su(SI)}$ | SDI input setup time | 5 | | |
| $t_h(SI)$ | SDI input hold time | 15 | | |
| $t_{v(SO)}$ | SDO valid output time | | 50 | |
| $t_h(SO)$ | SDO output hold time | 6 | | |
| $t_{dis(SO)}$ | SDO output disable time | | 50 | |

1. Values are guaranteed at 10 MHz clock frequency for SPI, based on characterization results, not tested in production.

Figure 3. SPI slave timing diagram

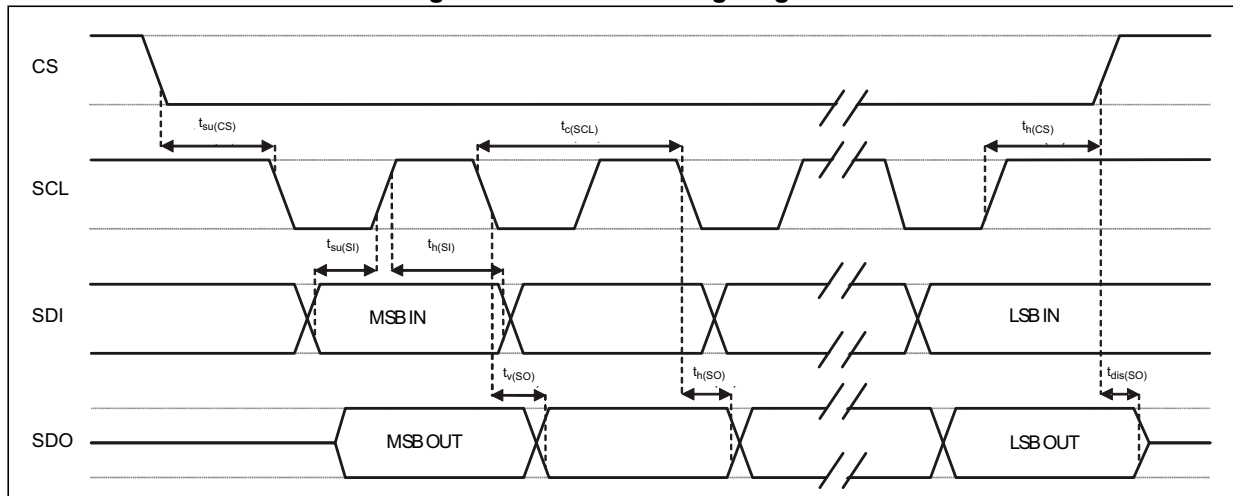

Note: Measurement points are done at $0.2 \cdot V_{dd_IO}$ and $0.8 \cdot V_{dd_IO}$, for both input and output ports.

3.5 Absolute maximum ratings

Stresses above those listed as “absolute maximum ratings” may cause permanent damage to the device. This is a stress rating only and functional operation of the device under these conditions is not implied. Exposure to maximum rating conditions for extended periods may affect device reliability.

Table 7. Absolute maximum ratings

| Symbol | Ratings | Maximum value | Unit |
|------------------|--|---------------------|----------|
| Vdd | Power supply | -0.3 to 4.8 | V |
| Vdd_IO | Power supply for I/O pins | -0.3 to Vdd | V |
| Vin | Input voltage on: (CS, SDI/SDO, SDO, SCL) | -0.3 to Vdd_IO +0.1 | V |
| T _{STG} | Storage temperature range | -40 to +125 | °C |
| Sg | Acceleration <i>g</i> for 0.2 ms | 10,000 | <i>g</i> |
| ESD | Electrostatic discharge protection | 2 (HBM) | kV |

Note: Supply voltage on any pin should never exceed 4.8 V.



This device is sensitive to mechanical shock, improper handling can cause permanent damage to the part.



This device is sensitive to electrostatic discharge (ESD), improper handling can cause permanent damage to the part.

4 Application hints

Figure 4. L2G2IS electrical connections and external components

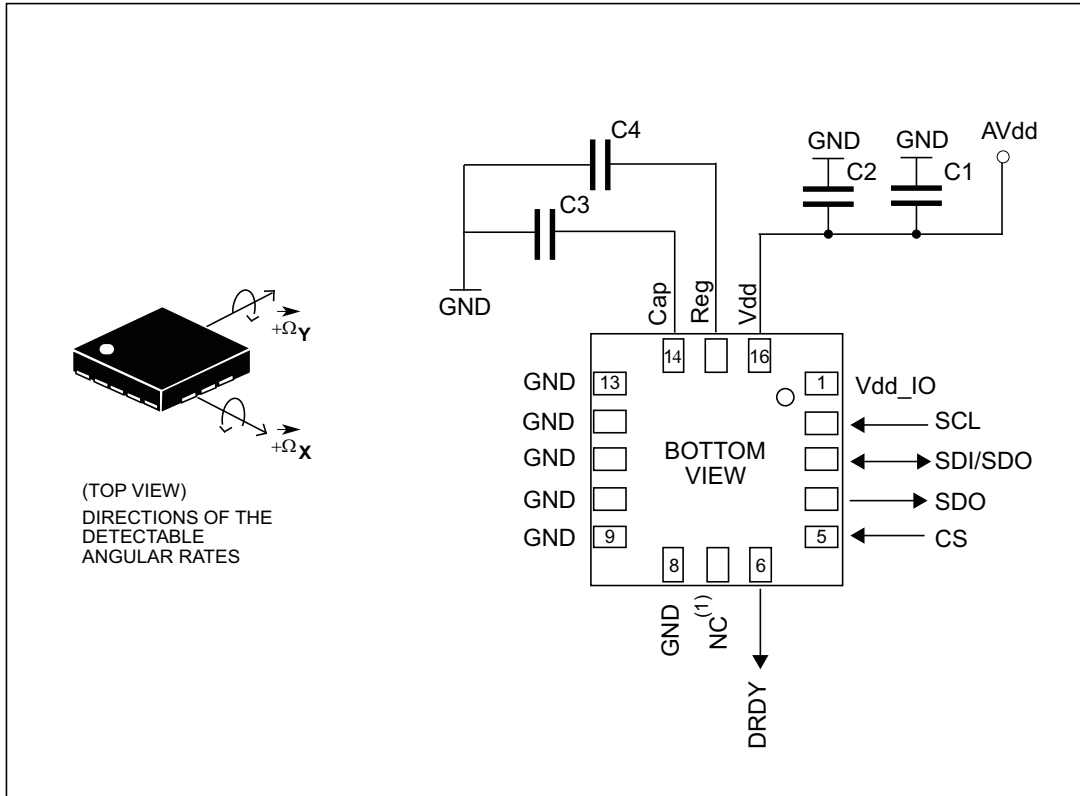

1. Leave pin electrically unconnected and soldered to PCB.

Table 8. External component values

| Name | Value | Purpose |
|-------------------|--------------------|--------------------|
| C1 | 1 μ F | Decoupling |
| C2 | 100 pF | Decoupling |
| C3 ⁽¹⁾ | 10 nF (16 V class) | Charge pump |
| C4 | 100 nF (5 V class) | Internal regulator |

1. This value must guarantee a minimum of 1 nF value under 12 V bias condition.

Power supply decoupling capacitors (100 pF + 1 μ F) should be placed as near as possible to the device (common design practice).

5 Digital interfaces

The registers embedded inside the L2G2IS may be accessed through the SPI serial interfaces.

Table 9. Serial interface pin description

| Pin name | Pin description |
|----------|--|
| CS | Chip-select line |
| SCL | SPI serial port clock |
| SDI/SDO | Serial data input (SDI) 3-wire interface serial data output (SDO) |
| SDO | Serial data output (SDO) |

5.1 SPI bus interface

The SPI is a bus slave. The SPI allows to write and read the registers of the device.

The serial interface connects to applications using 4 wires: **CS**, **SCL**, **SDI** and **SDO**.

CS is the serial port enable and it is controlled by the SPI master. It goes low at the start of the transmission and goes back high at the end. **SCL** is the serial port clock and it is controlled by the SPI master. It is stopped high when **CS** is high (no transmission). **SDI** and **SDO** are respectively the serial port data input and output. Those lines are driven at the falling edge of **SCL** and should be captured at the rising edge of **SCL**.

Both the read register and write register commands are completed in 16 clock pulses or in multiples of 8 in case of multiple read/write bytes. Bit duration is the time between two falling edges of **SCL**. The first bit (bit 0) starts at the first falling edge of **SCL** after the falling edge of **CS** while the last bit (bit 15, bit 23, ...) starts at the last falling edge of **SCL** just before the rising edge of **CS**.

bit 0: \overline{RW} bit. When 0, the data DI(7:0) is written into the device. When 1, the data DO(7:0) from the device is read. In latter case, the chip will drive SDO at the start of bit 8.

bit 1-7: address AD(6:0). This is the address field of the indexed register.

bit 8-15: data DI(7:0) (write mode). This is the data that is written into the device (MSb first).

bit 8-15: data DO(7:0) (read mode). This is the data that is read from the device (MSb first).

The function and the behavior of SDI and SDO remain unchanged.

5.1.1 SPI read

Figure 5. SPI read protocol

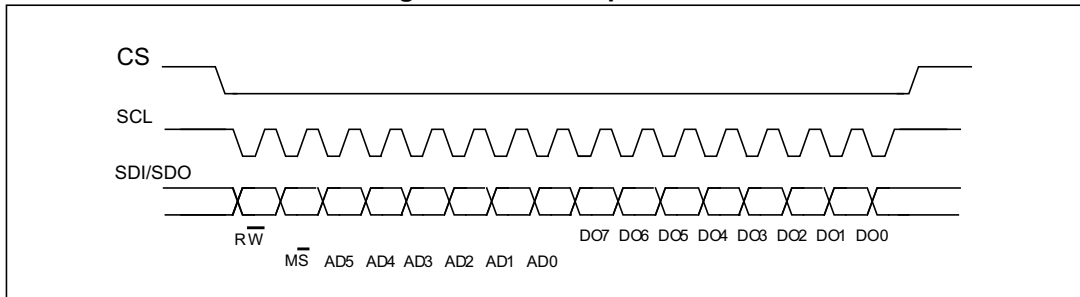

The SPI read command is performed with 16 clock pulses:

bit 0: READ bit. The value is 1.

bit 1: \overline{MS} bit. When 0, does not increment the address; when 1, increments the address in multiple reads.

bit 2-7: address AD(5:0). This is the address field of the indexed register.

bit 8-15: data DO(7:0) (read mode). This is the data that will be read from the device (MSb first).

A multiple read command is also available.

5.1.2 SPI write

Figure 6. SPI write protocol

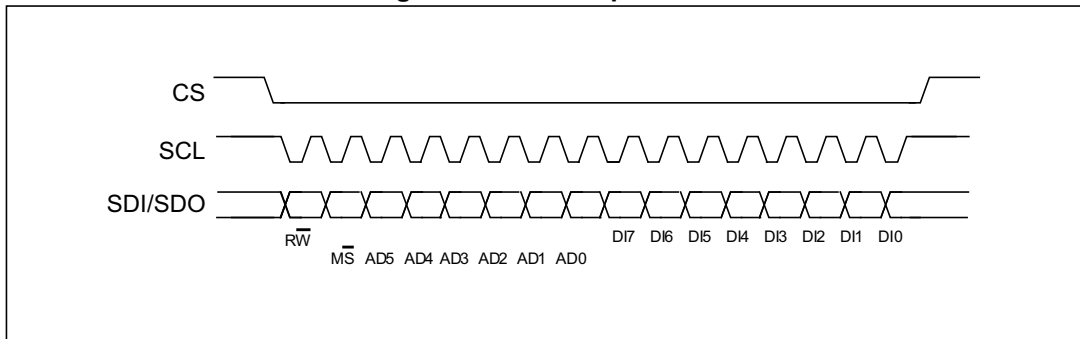

The SPI write command is performed with 16 clock pulses. A multiple byte write command is performed by adding blocks of 8 clock pulses to the previous one.

bit 0: WRITE bit. The value is 0.

bit 1: \overline{MS} bit. When 0, does not increment the address; when 1, increments the address in multiple writes.

bit 2 -7: address AD(5:0). This is the address field of the indexed register.

bit 8-15: data DI(7:0) (write mode). This is the data that will be written inside the device (MSb first).

bit 16-... : data DI(...-8). Further data in multiple byte writes.

Figure 7. Multiple byte SPI write protocol (2-byte example)

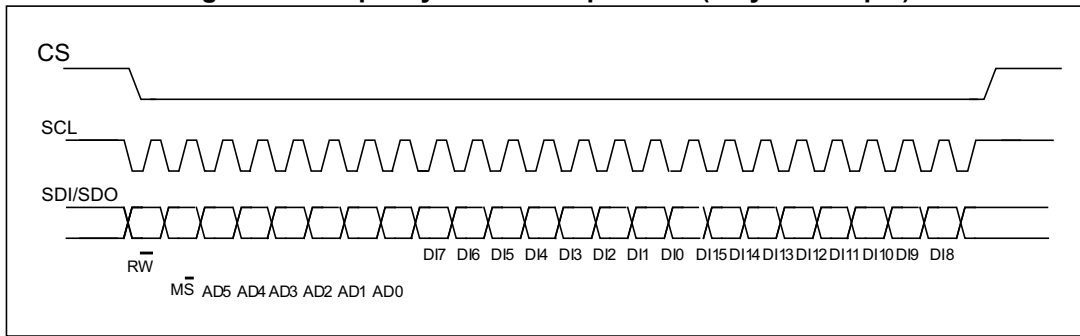

5.1.3 SPI read in 3-wire mode

3-wire mode is entered by setting the *CTRL_REG1 (0Bh)* (SIM) bit equal to '1' (SPI serial interface mode selection).

Figure 8. SPI read protocol in 3-wire mode

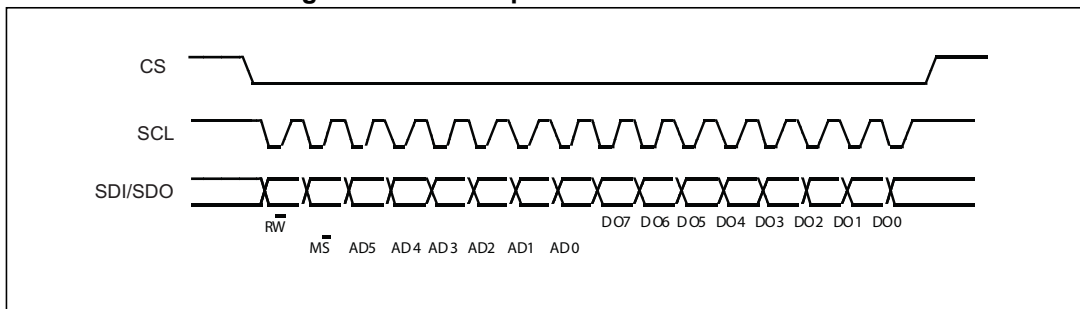

The SPI Read command is performed with 16 clock pulses:

bit 0: READ bit. The value is 1.

bit 1: MS bit. When 0, does not increment the address; when 1, increments the address in multiple reads.

bit 2-7: address AD(5:0). This is the address field of the indexed register.

bit 8-15: data DO(7:0) (read mode). This is the data that will be read from the device (MSb first).

A multiple read command is also available in 3-wire mode.

6 Output register mapping

The table given below provides a listing of the 8-bit registers embedded in the device and the related addresses.

Table 10. Register address map

| Name | Type | Register address [Hex] | Default [Hex] | Comment |
|---------------|------|------------------------|---------------|----------|
| WHO_AM_I | r | 00 | D9 | |
| TEMP_OUT_L | r | 01 | output | |
| TEMP_OUT_H | r | 02 | output | |
| OUT_X_L | r | 03 | output | |
| OUT_X_H | r | 04 | output | |
| OUT_Y_L | r | 05 | output | |
| OUT_Y_H | r | 06 | output | |
| Reserved | -- | 07-08 | -- | |
| STATUS_REG | r | 09 | output | |
| Reserved | -- | 0A | -- | Reserved |
| CTRL_REG1 | r/w | 0B | 00 | |
| CTRL_REG2 | r/w | 0C | 00 | |
| CTRL_REG3 | r/w | 0D | 00 | |
| Reserved | -- | 0E-0F | -- | Reserved |
| ORIENT_CONFIG | r/w | 10 | 00 | |
| OFF_X | r/w | 11 | 00 | |
| OFF_Y | r/w | 12 | 00 | |
| Reserved | -- | 13-1E | -- | Reserved |
| CTRL_REG4 | r/w | 1F | 00 | |

Registers marked as *Reserved* must not be changed. Writing to those registers may cause permanent damage to the device.

To guarantee the proper behavior of the device, all register addresses not listed in the above table must not be accessed and the content stored in those registers must not be changed.

The content of the registers that are loaded at boot should not be changed. They contain the factory calibration values. Their content is automatically restored when the device is powered up.

7 Register description

The device contains a set of registers which are used to control its behavior and to retrieve angular rate data. The register address, consisting of 7 bits, is used to identify them and to write the data through the serial interface.

7.1 WHO_AM_I (00h)

Table 11. WHO_AM_I register

| | | | | | | | |
|---|---|---|---|---|---|---|---|
| 1 | 1 | 0 | 1 | 1 | 0 | 0 | 1 |
|---|---|---|---|---|---|---|---|

7.2 TEMP_OUT_L (01h), TEMP_OUT_H (02h)

Table 12. TEMP_OUT_L register

| | | | | | | | |
|-------|-------|-------|-------|---|---|---|---|
| Temp3 | Temp2 | Temp1 | Temp0 | 0 | 0 | 0 | 0 |
|-------|-------|-------|-------|---|---|---|---|

Table 13. TEMP_OUT_H register

| | | | | | | | |
|--------|--------|-------|-------|-------|-------|-------|-------|
| Temp11 | Temp10 | Temp9 | Temp8 | Temp7 | Temp6 | Temp5 | Temp4 |
|--------|--------|-------|-------|-------|-------|-------|-------|

Table 14. TEMP_OUT resolution

| | |
|--------------|---|
| Temp11-Temp0 | Temperature data. Refer to: Section 2.4: Temperature sensor on how to read the temperature sensor output data. |
|--------------|---|

7.3 OUT_X_L (03h), OUT_X_H (04h)

X-axis angular rate data. The value is expressed as two's complement.

7.4 OUT_Y_L (05h), OUT_Y_H (06h)

Y-axis angular rate data. The value is expressed as two's complement.

7.5 STATUS_REG (09h)

Table 15. STATUS_REG register

| | | | | | | | |
|------|-----|-----|---|------|-----|-----|---|
| YXOR | XOR | YOR | 0 | YXDA | XDA | YDA | 0 |
|------|-----|-----|---|------|-----|-----|---|

Table 16. STATUS_REG description

| | |
|------|--|
| YXOR | X-, Y-axis data overrun. (0: no overrun has occurred; 1: new data has overwritten the previous data before it was read) |
| XOR | X-axis data overrun. (0: no overrun has occurred; 1: new data for the X-axis has overwritten the previous data) |
| YOR | Y-axis data overrun. (0: no overrun has occurred; 1: new data for the Y-axis has overwritten the previous data) |
| YXDA | X-, Y-axis new data available. (0: a new set of data is not yet available; 1: a new set of data is available) |
| XDA | X-axis new data available. (0: new data for the X-axis is not yet available; 1: new data for the X-axis is available) |
| YDA | Y-axis new data available. (0: new data for the Y-axis is not yet available; 1: new data for the Y-axis is available) |

7.6 CTRL_REG1 (0Bh)

Table 17. CTRL_REG1 register

| | | | | | | | |
|------|--------|-----|-----|-----|------------------|-----|-----|
| BOOT | P_DRDY | BLE | SIM | ODU | 0 ⁽¹⁾ | PW1 | PW0 |
|------|--------|-----|-----|-----|------------------|-----|-----|

1. This bit must be set to '0' for proper operation of the device.

Table 18. CTRL_REG1 description

| | |
|---------|---|
| BOOT | Reboot memory content. Default value: 0 (0: normal mode; 1: reboot memory content ⁽¹⁾) |
| P_DRDY | DRDY signal pulsed. Default value: 0 (0: DRDY is latched; 1: DRDY is pulsed) |
| BLE | Big/little endian data selection. Default value: 0 (0: Data LSB @ lower address; 1: Data MSB @ lower address) |
| SIM | SPI Serial Interface Mode selection. Default value: 0 (0: 4-wire interface; 1: 3-wire interface). |
| ODU | Output data update. Default value: 0 (0: output registers not updated until MSB and LSB have been read; 1: output registers updated continuously) |
| PW[1:0] | Operating mode selection. Default value: 00 Refer to Table 19: Operating mode selection . |

1. Boot request is executed as soon as internal oscillator is turned-on. It is possible to set this bit while in power-down mode, in this case it will be served at the next normal mode or sleep mode.

Table 19. Operating mode selection

| PW1 | PW0 | Operating mode selection |
|-----|-----|--------------------------|
| 0 | 0 | Power-down |
| 0 | 1 | Power-down |
| 1 | 0 | Sleep mode |
| 1 | 1 | Normal mode |

7.7 CTRL_REG2 (0Ch)

Table 20. CTRL_REG2 register

| | | | | | | | |
|-------|------------------|------------------|------------------|------------------|---------|---------|-----|
| LPF_O | 0 ⁽¹⁾ | 0 ⁽¹⁾ | 0 ⁽¹⁾ | 0 ⁽¹⁾ | HPreSet | SWreset | HPF |
|-------|------------------|------------------|------------------|------------------|---------|---------|-----|

1. These bits must be set to '0' for proper operation of the device.

Table 21. CTRL_REG2 description

| | |
|---------|---|
| LPF_O | Low-pass filter order selection. Default value: 0 (0: 2nd order; 1: 1st order). Refer to Figure 9: LPF chain block diagram and Table 24: Low-pass filter cutoff frequency selection |
| HPreSet | High-pass filter reset. Default value: 0 (1: HPF reset on X and Y-axis) |
| SWreset | Software reset. Default value: 0 (1: all the configuration register values are restored to default values). |
| HPF | High-pass filter enable. Default value: 0 (0: high-pass filter is disabled; 1: high-pass filter is enabled) |

7.8 CTRL_REG3 (0Dh)

Table 22. CTRL_REG3 register

| | | | | | | | |
|------------------|----|------------------|-------|------------------|------------------|---------|-------|
| 0 ⁽¹⁾ | ST | 0 ⁽¹⁾ | PP_OD | 0 ⁽¹⁾ | 0 ⁽¹⁾ | DRDY_EN | LPF_D |
|------------------|----|------------------|-------|------------------|------------------|---------|-------|

1. These bits must be set to '0' for proper operation of the device.

Table 23. CTRL_REG3 description

| | |
|---------|--|
| ST | Self-test enable. Default value: 0 (0: Self-test disabled; 1: Self-test enabled) |
| PP_OD | DRDY pin configuration. Default value: 0 (0: push-pull; 1: open drain) |
| DRDY_EN | Data ready enable on DRDY pin. Default: 0 (1: DRDY on pin). Section 2.3: Data-ready interrupt and synchronous reading. |
| LPF_D | Digital low-pass filter enable. Default value: 0 (0: digital low-pass filter disabled; 1: digital low-pass filter enabled). Refer to Figure 9: LPF chain block diagram and Table 24: Low-pass filter cutoff frequency selection. |

Figure 9. LPF chain block diagram

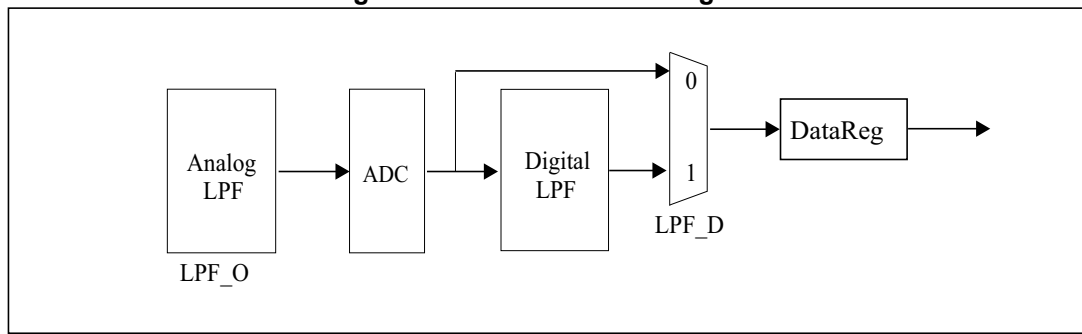

Table 24. Low-pass filter cutoff frequency selection

| LPF_O (<i>CTRL_REG2 (0Ch)</i>) | LPF_D (<i>CTRL_REG3 (0Dh)</i>) | BW (Hz) | Phase delay @ 20 Hz |
|----------------------------------|----------------------------------|---------|---------------------|
| 0 | 0 | 280 | 7 deg (default) |
| 0 | 1 | 140 | 13.5 deg |
| 1 | 0 | 350 | 5 deg |
| 1 | 1 | 150 | 11.5 deg |

7.9 ORIENT_CONFIG (10h)

Table 25. ORIENT_CONFIG register

| | | | | | | | |
|------------------|------------------|--------|--------|------------------|------------------|------------------|--------|
| 0 ⁽¹⁾ | 0 ⁽¹⁾ | Sign_x | Sign_y | 0 ⁽¹⁾ | 0 ⁽¹⁾ | 0 ⁽¹⁾ | Orient |
|------------------|------------------|--------|--------|------------------|------------------|------------------|--------|

1. These bits must be set to '0' for proper operation of the device.

Table 26. ORIENT_CONFIG description

| | |
|--------|---|
| Sign_x | X-axis angular rate sign. Default value: 0 (0: sign unvaried; 1: sign inverted) |
| Sign_y | Y-axis angular rate sign. Default value: 0 (0: sign unvaried; 1: sign inverted) |
| Orient | Directional orientation selection. Default value: 0 (0: X-axis - Y-axis; 1: Y-axis - X-axis) |

7.10 OFF_X (11h)

Table 27. OFF_X register

| | | | | | | | |
|-------|-------|-------|-------|-------|-------|-------|-------|
| OFFX7 | OFFX6 | OFFX5 | OFFX4 | OFFX3 | OFFX2 | OFFX1 | OFFX0 |
|-------|-------|-------|-------|-------|-------|-------|-------|

Table 28. OFF_X description

| | |
|-----------|---|
| OFFX[7:0] | User offset correction register for X-axis. Default value: 0000 0000 The value is expressed as two's complement. |
|-----------|---|

7.11 OFF_Y(12h)

Table 29. OFF_Y register

| | | | | | | | |
|-------|-------|-------|-------|-------|-------|-------|-------|
| OFFY7 | OFFY6 | OFFY5 | OFFY4 | OFFY3 | OFFY2 | OFFY1 | OFFY0 |
|-------|-------|-------|-------|-------|-------|-------|-------|

Table 30. OFF_Y description

| | |
|-----------|---|
| OFFY[7:0] | User offset correction register for Y-axis. Default value: 0000 0000 The value is expressed as two's complement. |
|-----------|---|

7.12 CTRL_REG4 (1Fh)

Table 31. CTRL_REG4 register

| | | | | | | | |
|------------------|------------------|------------------|------------------|----|------------------|------------------|--------|
| 0 ⁽¹⁾ | 0 ⁽¹⁾ | 0 ⁽¹⁾ | 0 ⁽¹⁾ | FS | 0 ⁽¹⁾ | 0 ⁽¹⁾ | HPF_BW |
|------------------|------------------|------------------|------------------|----|------------------|------------------|--------|

1. These bits must be set to '0' for proper operation of the device.

Table 32. CTRL_REG4 description

| | |
|--------|---|
| FS | Full-scale selection. Default value: 0 (0: ±100 dps; 1: ±200 dps) |
| HPF_BW | Digital high-pass filter cutoff frequency selection. Default value: 0 Refer to Table 33: High-pass filter cutoff frequency selection |

Table 33. High-pass filter cutoff frequency selection

| HPF_BW0 | HP cutoff frequency selection |
|---------|-------------------------------|
| 0 | 0.02 Hz |
| 1 | 0.09 Hz |

8 Package information

In order to meet environmental requirements, ST offers these devices in different grades of ECOPACK® packages, depending on their level of environmental compliance. ECOPACK® specifications, grade definitions and product status are available at: www.st.com. ECOPACK® is an ST trademark.

8.1 Soldering information

The LGA package is compliant with the ECOPACK®, RoHS and “Green” standard. It is qualified for soldering heat resistance according to JEDEC J-STD-020.

Leave “Pin 1 Indicator” unconnected during soldering.

Land pattern and soldering recommendations are available at www.st.com/mems.

8.2 LGA-16 package

Figure 10. LGA-16 package outline and dimensions

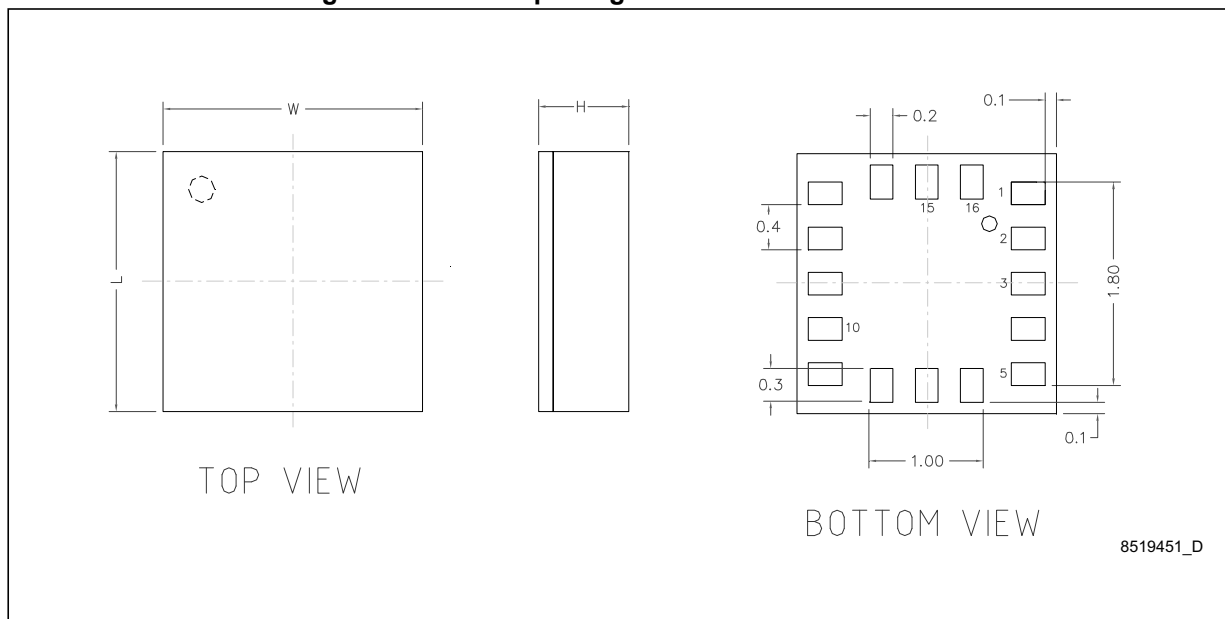

Table 34. LGA-16 package outer dimensions

| Item | Dimension [mm] | Tolerance [mm] |
|------------|----------------|----------------|
| Length [L] | 2.30 | ±0.1 |
| Width [W] | 2.30 | ±0.1 |
| Height [H] | 0.70 | MAX |

9 Revision history

Table 35. Document revision history

| Date | Revision | Changes |
|-------------|----------|---|
| 16-Mar-2015 | 1 | Initial release |
| 17-Feb-2016 | 2 | Added footnote to pin 7 in <i>Figure 2</i> , <i>Table 2</i> , and <i>Figure 4</i> Updated <i>Section 2.3: Data-ready interrupt and synchronous reading</i> Updated Sg in <i>Table 7: Absolute maximum ratings</i> |

IMPORTANT NOTICE – PLEASE READ CAREFULLY

STMicroelectronics NV and its subsidiaries (“ST”) reserve the right to make changes, corrections, enhancements, modifications, and improvements to ST products and/or to this document at any time without notice. Purchasers should obtain the latest relevant information on ST products before placing orders. ST products are sold pursuant to ST’s terms and conditions of sale in place at the time of order acknowledgement.

Purchasers are solely responsible for the choice, selection, and use of ST products and ST assumes no liability for application assistance or the design of Purchasers’ products.

No license, express or implied, to any intellectual property right is granted by ST herein.

Resale of ST products with provisions different from the information set forth herein shall void any warranty granted by ST for such product.

ST and the ST logo are trademarks of ST. All other product or service names are the property of their respective owners.

Information in this document supersedes and replaces information previously supplied in any prior versions of this document.

© 2016 STMicroelectronics – All rights reserved