



Data Sheet

VI-RAM™, VE-RAM (RoHS Compliant)

Ripple Attenuator Modules



Features

- RoHS compliant (VE versions)
- Reduces output ripple to <3 mV pp
- Compatible with any VI-200/VI-J00-based product: 5 to 50 Vdc output
- Full attenuation up to 20 A
- No adjustments required
- 93-99% efficiency
- Converter sense, trim, overvoltage and overcurrent retained
- Size: 2.28" x 2.4" x 0.5" (57,9 x 61,0 x 12,7)
- CE Marked

Product Highlights

Ripple attenuator modules may be connected to VI-200 or VI-J00 converters, FlatPACs, MegaPACs, MasterModules or MegaModules, with output voltages from 5 to 50V, to limit output noise to less than 3mV peak-to-peak at loads up to 20A. Combining active and passive filtering, the VI-RAM attenuates both low frequency input power source fundamental and harmonics, and high frequency switching components in the frequency range of DC to 20 MHz, while exhibiting efficiencies of 93-99%. No adjustments are required, and remote sense and output voltage trim features are retained.

A member of Vicor's high-power density, high performance, component-level power building blocks, the VI-RAM offers the power systems architect a single, flexible, component-level solution to almost any "clean power" problem. At the same time, the VI-RAM eliminates the space, efficiency, and weight penalties associated with linear power sources, and the stability, efficiency, and adjustment penalties associated with external "add on" filters for conventional switchers.

VI-RAM Specifications

(typical at $T_{BP} = 25^{\circ}\text{C}$, nominal line, 75% load unless otherwise specified)

Parameter	Min.	Typ.	Max.	Remarks
Output Noise & Ripple				
VI-200			3 mV pp	From 10% of full rated
VI-J00			10 mV pp	output current of the
				source converter to full load
Input Voltage Range	5 Vdc		50 Vdc	
Output Voltage Deviation		0.5%		From the output voltage of the
				VI-200 source to which the
				VI-RAM will be connected
Full Load Current			10Amps	E1, C1, I1 or M1
			20Amps	E2, C2, I2 or M2
Overload Current			30Amps	At max. allowable baseplate
				temperature
DC Voltage Drop	0.34		0.41	Up to 10Amps
	0.34		0.44	Up to 20Amps
	0.34		0.75	Up to 30Amps (overload)
	Dissipation = (DC voltage drop) x (Load current + 15 mA)			
Isolation		500V _{RMS}		Input/Output to baseplate
Size	2.28" x 2.4" x 0.5"			SlimMod and FinMod
	(57,9 x 61,0 x 12,7)			packages available
Weight	3.0 Ounces (85 Grams)			

Electrical Considerations

Transient Response and Dynamic Range: Full rated noise attenuation will be maintained at the VI-RAM output for step load changes up to 10% of the rated output current of the source converter, with the VI-RAM exhibiting an underdamped output excursion of less than 10 mV pp. Some degradation in noise attenuation during the transient response period following the step may be exhibited for larger load changes. Adding output capacitance to the VI-RAM will improve the rejection over a larger dynamic range.

Sense Connection: Sense-in and sense-out connections are provided on the VI-RAM. Sense-in connections must be connected to the corresponding sense connections on the Vicor converter. Sense-out pins on the VI-RAM must be connected between the VI-RAM power-output pins, and the point of load.

Output Load Characteristics: When used in combination with Vicor DC-DC converters, and with sense leads connected, the VI-RAM will be stable for any non-inductive load.

DC Voltage Drop: Below full load, the input to output DC Voltage Drop is controlled to be an essentially constant voltage which appears between the -IN and -OUT terminals. In overload the DC voltage drop will rise as current increases. A few tens of millivolts appears between the +IN and +OUT terminals. Care should be taken not to connect IN and OUT terminals (i.e. through scope probe returns, grounds, etc.), as attenuation will be adversely affected.

Product Grade Specifications

Parameter (Up to 10A) (Up to 20A)	VI-RAM-E1	VI-RAM-C1	VI-RAM-I1	VI-RAM-M1
	VI-RAM-E2	VI-RAM-C2	VI-RAM-I2	VI-RAM-M2
Storage Temp.	-20°C to +105°C	-40°C to +105°C	-55°C to +105°C	-65°C to +105°C
Operating Temp. (Baseplate)	-10°C to +100°	-25°C to +100°C	-40°C to +100°C	-55°C to +100°C

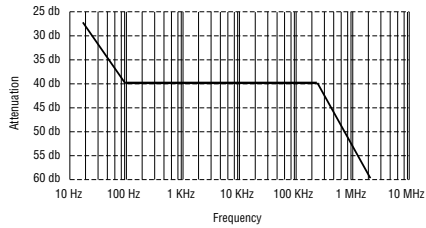

Attenuation vs. Frequency (typical)

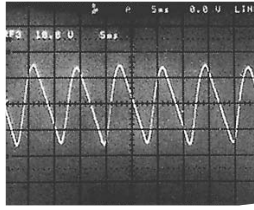

Input to the converter
10 V/cm

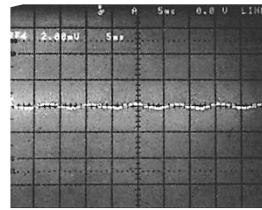

Output from the RAM
20 mV/cm

Connection Diagram

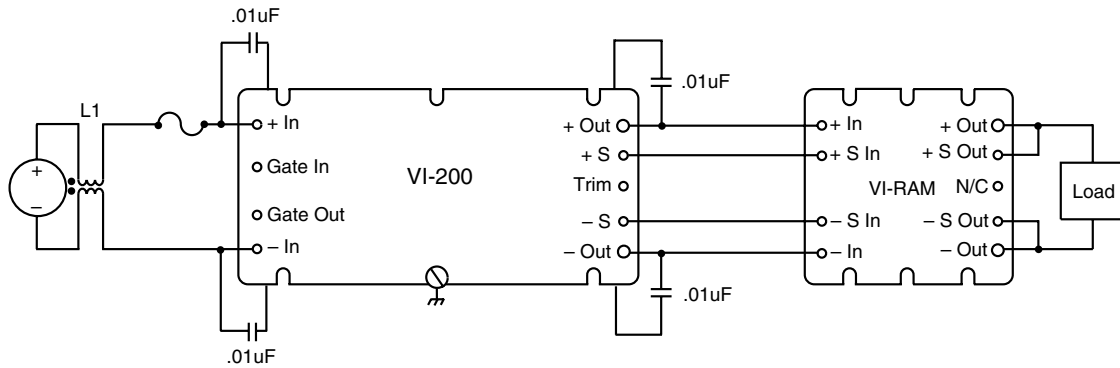

Mechanical Drawing

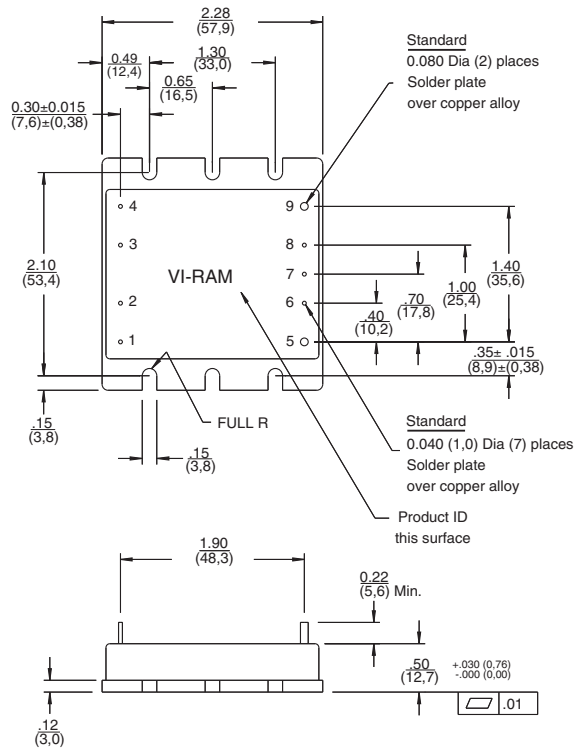

RoHS
0.080 Dia (2) places
Solder plate
Matte tin over copper
alloy

Pin #	Function
1	+In
2	+Sense In
3	-Sense In
4	-In
5	+Out
6	+Sense
7	NC
8	-Sense
9	-Out

RoHS
0.040 (1,0) Dia (7) places
Solder plate
Matte tin over copper
alloy

