

Multilayer Ceramic Chip Capacitors

江苏芯声微电子科技有限公司

Jiangsu Holy Ram Electronics
Technology Limited

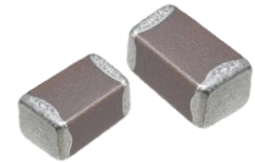

CSA 系列 (一般通用型, Commercial Grade)

材质	X7R	X7S	X6S	X5R	C0G	M3L
温度范围	-55°C--125°C	-55°C--125°C	-55°C--105°C	-55°C--85°C	-55°C--125°C	-55°C--125°C
容值变化率	±15%	±22%	±22%	±15%	±30ppm/°C	-500ppm/°C ~1500ppm/°C

使用注意事项

在使用本产品前，请务必随附采购规格书。

安全注意事项

使用本产品时，请注意安全事项。

应用限制

在使用我们的产品之前，请与我们联系以下所列的应用，特别要求高的可靠性，以防止可能直接对第三方的生命，身体或财产造成损害的缺陷。

- ①飞机设备
- ②航空航天设备
- ③海底设备
- ④电厂控制设备
- ⑤医疗设备
- ⑥交通设备(车辆、火车、船舶等)
- ⑦交通信号设备
- ⑧防灾/预防犯罪设备
- ⑨数据处理设备
- ⑩复杂度和/或可靠性要求与上述应用类似的应用。

运输与储存方法

1.运输

包装的产品适应现代交通工具运输，在运输过程中要防止雨淋和酸碱腐蚀，不得重力抛掷和猛力挤压。

2.储存(Refer to IEC 61760-2,Clause 6 Storage conditions/IEC 60721-3-1:2018,class 1K21)

确保产品可焊性良好的贮存期限为：自生产之日保存期为两年，产品使用之前请勿拆开编带(在包装好已交付的情况下)，编带拆开后，产品应在三个月内使用。

- 储存温度: 5°C~40°C
- 储存相对湿度: 10%~75%
- 环境: 无有害化学物质环境
- 包装: 芯声原厂包装
- 太阳辐射: 700 W/m²，应避免直接光源照射

特性

- 符合 IEC60384 标准
- 通过无铅认证
- 无卤素
- 无极性

应用

- 一般电子设备。
- 移动设备
- 服务器, 电脑, 平板电脑
- 电源电路

产品结构图

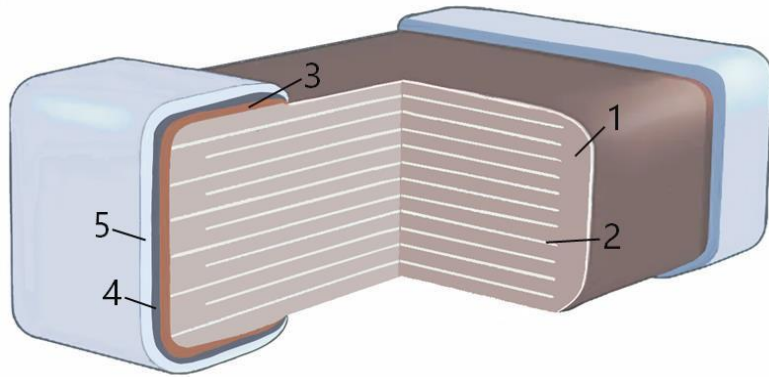

序号	名称
1	介电陶瓷
2	内电极 (镍)
3	外电极 (铜)
4	镍层
5	锡层

产品型号命名规则

EX: C SA 0402 X7R 104 K 500 G T
 (1) (2) (3) (4) (5) (6) (7) (8) (9)

(1)	C: MLCC			(5) 电容容值	容值 ≥ 10pF 的表示方式: First Two × 10 ^{third} 104 = 10 × 10 ⁴ = 100nF 123 = 12 × 10 ³ = 12nF 容值 < 10pF 的表示方式: R30 = 0.3pF, 1R0 = 1pF					
(2)应用	SA: 一般通用型									
(3) 产品尺寸	编码	英制 (inch)	公制 (mm)							
	00R4	008004	0201							
	01R5	01005	0402							
	0201	0201	0603	(6) 容值允差	A: ±0.05pF	B: ±0.1pF	C: ±0.25pF	D: ±0.5pF	F: ±1.0%	G: ±2%
	0402	0402	1005		J: ±5%	K: ±10%	M: ±20%			
	0603	0603	1608	(7) 额定电压	2R5:2.5	4R0:4.0	6R3:6.3	100:10	160:16	250:25
	0805	0805	2012		350:35	500:50	630:63	101:100	201:200	251:250
	1206	1206	3216		451:450	501:500	631:630	102:1000	202:2000	252:2500
	1210	1210	3225		302:3000	402:4000				
	1808	1808	4520	(8) 产品厚度	A:0.10	B:0.13	C:0.18	D:0.20	E:0.30	F:0.45
1812	1812	4532	G:0.50		H:0.60	J:0.80	K:0.85	L:1.15	M:1.25	
2220	2220	5750	N:1.60		P:1.90	Q:2.00	S:2.30	R:2.50		
(4) 温度特性	Class I : C0G M3L Class II : X7R X7S X6S X5R			(9) 包装方式	T: 成品包装 (7 "Reel) D: 成品包装 (13 "Reel)					

尺寸&包装规格

一般情况下使用 $\Phi 180\text{mm}$ (7") 的料盘进行包装。

每 5 盘封装为一盒，每 12 盒为一整箱。

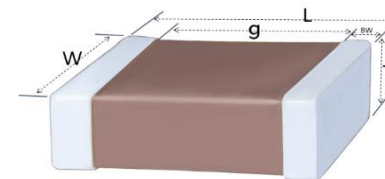

规格	尺寸 (mm)					包装 (7")	
	Length	Width	Thickness	g	BW	包装数量 (颗)	包装方式
01R5	0.40±0.02	0.20±0.02	0.20±0.02	0.13	0.07-0.13	20,000	纸带
0201	0.60±0.03	0.30±0.03	0.30±0.03	0.20	0.10-0.25	15,000	纸带
	0.60+0.10/-0.03	0.30+0.10/-0.03	0.30+0.10/-0.03				
0402	1.00±0.05	0.50±0.05	0.50±0.05	0.30	0.15-0.35	10,000	纸带
	1.00±0.07	0.50±0.07	0.50±0.07				
	1.00±0.10	0.50±0.10	0.50±0.10				
	1.00+0.20/-0.05	0.50+0.20/-0.05	0.50+0.20/-0.05				
0603	1.60±0.10	0.80±0.10	0.80±0.10	0.50	0.20-0.65	4,000	纸带
	1.60±0.20	0.80±0.20	0.80±0.20				
0805	2.00±0.10	1.25±0.10	0.60±0.10	0.70	0.20-0.70	4,000	纸带
			0.85±0.10				
	2.00±0.20	1.25±0.20	1.25±0.20				
1206	3.20±0.20	1.60±0.20	0.85±0.10	1.50	0.30-0.80	4,000	纸带
			1.25±0.20				
			1.60±0.20				
	3.20±0.30	1.60±0.30	1.60±0.30				
						2,000	塑胶带
						2,000	塑胶带
1210	3.20±0.30	2.50±0.20	0.85±0.10	1.50	0.30-0.80	2,000	塑胶带
			1.25±0.20				
			1.60±0.20				
			2.00±0.20				
	3.20±0.40	2.50±0.30	2.50±0.30				
						2,000/1,000	塑胶带

规格	尺寸 (mm)					包装 (7")	
	Length	Width	Thickness	g	BW	包装数量 (颗)	包装方式
1808	4.50±0.40	2.00±0.30	1.25±0.20	2.20	0.25-0.75	2,000	塑胶带
			1.60±0.20			2,000	塑胶带
			2.00±0.20			1,000	塑胶带
1812	4.50±0.30	3.2±0.30	1.25±0.20	2.20	0.25-0.75	1,000	塑胶带
			1.60±0.20			1,000	塑胶带
	4.50±0.40	3.2±0.40	2.00±0.20			1,000	塑胶带
			2.50±0.30			500/1,000	塑胶带
2220	5.70±0.40	5.0±0.40	1.25±0.2	3.80	0.25-0.75	1,000	塑胶带
			1.60±0.20			700	塑胶带
			2.00±0.20			700	塑胶带
			2.50±0.3			700	塑胶带

*详情请参考单颗规格书

容值范围

【COG】 01005~1206

Size (inch)	Thick (mm)	RV (Vdc)	CSA Series - COG																														
			R10	R20	R30	R47	1R0	2R2	4R7	6R8	100	150	220	330	390	470	680	101	151	221	331	471	681	102	152	222	332	472	682	103	223		
01005	0.20 (D)	16																															
		25																															
0201	0.30 (E)	25																															
		50																															
0402	0.50 (G)	16																															
		25																															
		50																															
		100																															
0603	0.80 (J)	25																															
		50																															
		100																															
		250																															
0805	0.60 (H)	50																															
		100																															
		250																															
		500																															
0805	0.85 (K)	250																															
		500																															
0805	1.25 (M)	50																															
		1000																															
1206	0.85 (K)	50																															
		100																															
		250																															
		500																															
	1.25 (M)	50																															
		100																															
500																																	
1.60	50																																
	100																																
	630																																

【X7R/X7S/X7T】 01005~1812

Size (inch)	Thick (code)	RV (Vdc)	CSA Series - X7R/X7S/X7T																							
			101	151	221	331	471	681	102	152	222	332	472	682	103	223	473	683	104	224	474	105	225	475	106	
1005	0.20(D)	25	[Grid]																							
0201	0.30 (E)	6.3	[Grid]																							
		10	[Grid]																							
		16	[Grid]																							
		25	[Grid]																							
		50	[Grid]																							
0402	0.50 (G)	6.3	[Grid]																							
		10	[Grid]																							
		16	[Grid]																							
		25	[Grid]																							
		50	[Grid]																							
		100	[Grid]																							
0603	0.80 (J)	6.3	[Grid]																							
		10	[Grid]																							
		16	[Grid]																							
		25	[Grid]																							
		50	[Grid]																							
		100	[Grid]																							
0805	1.25 (M)	6.3	[Grid]																							
		10	[Grid]																							
		16	[Grid]																							
		25	[Grid]																							
		50	[Grid]																							
		100	[Grid]																							
0805	1.25 (M)	250	[Grid]																							
		500	[Grid]																							
		1000	[Grid]																							
		1000	[Grid]																							
		1000	[Grid]																							

X7T

Multilayer Ceramic Chip Capacitors

Size (inch)	Thick (mm)	RV (Vdc)	CSA Series - X7R/X7S/X7T																									
			221	331	471	681	102	152	222	332	472	682	103	153	223	333	473	683	104	224	474	105	225	475	106	226	476	
1206	0.85 (K)	50																										
		100																										
		250																										
		500																										
		630																										
	1.25 (M)	16																										
		25																										
		50																										
		100																										
		250																										
		500																										
		630																										
1.60 (N)	10																											
	16																											
	25																											
	35																											
	50																											
	100																											
	250																											
	500																											
	630																											
	2000																											
1210	1.25 (M)	500																										
		1000																										
	1.60 (N)	25																										
		50																										
		100																										
		500																										
		630																										
	2.00 (Q)	25																										
		50																										
		100																										
		250																										
		500																										
630																												
2.50 (R)	6.3																											
	10																											
	16																											
	25																											
	35																											
	50																											
	100																											
1808	2.00	3000																										
1812	1.25	2000																										
	1.60	2000																										
	2.00 (Q)	16																										
		25																										
		630																										
2.5	2000																											

【X5R】 01005~1210

Size (inch)	Thick (mm)	RV (Vdc)	CSA Series - X5R															
			153	223	333	473	104	224	474	105	225	475	106	226	476	107	227	
01005	0.20	6.3																
0201	0.30 (E)	6.3																
		10																
		16																
25																		
	0.50	6.3																
0402	0.50 (G)	6.3																
		10																
		16																
		25																
		50																
100																		
0603	0.80 (J)	6.3																
		10																
		16																
		25																
		35																
50																		
0805	1.25 (M)	6.3																
		10																
		16																
		25																
		35																
50																		
1206	1.60 (N)	6.3																
		10																
		16																
		25																
		35																
50																		
1210	2.00	25																
	2.50 (R)	6.3																
		10																
		16																
		25																

规格和测试方法

No	测试项目	测试规格	测试方法(参考标准:JIS C 5101, IEC60384)																								
1	外观 Appearance	无缺陷或异常。	目视(显微镜)检查产品。																								
2	尺寸 Dimension	符合尺寸规格。	使用千分尺检查设备的物理尺寸规范。																								
3	耐电压 Voltage proof	承受住测试电压, 无缺陷或异常。	<table border="1"> <thead> <tr> <th colspan="2">材质</th> <th>额定电压(RV)</th> <th>测试电压</th> </tr> </thead> <tbody> <tr> <td rowspan="4">Class I</td> <td rowspan="4">C0G/M3L</td> <td>RV ≤ 50V</td> <td>300% RV</td> </tr> <tr> <td>50V < RV ≤ 250V</td> <td>200% RV</td> </tr> <tr> <td>250V < RV ≤ 500V</td> <td>150% RV</td> </tr> <tr> <td>500V < RV ≤ 1000V</td> <td>130% RV</td> </tr> <tr> <td rowspan="4">Class II</td> <td rowspan="4">X7R/X7S X5R/X6S</td> <td>RV ≤ 50V</td> <td>250% RV</td> </tr> <tr> <td>50V < RV ≤ 250V</td> <td>200% RV</td> </tr> <tr> <td>250V < RV ≤ 630V</td> <td>150% RV</td> </tr> <tr> <td>630V < RV ≤ 1000V</td> <td>120% RV</td> </tr> </tbody> </table> <p>测试时间 1 到 5 秒 充电/放电电流 最大 50mA</p>	材质		额定电压(RV)	测试电压	Class I	C0G/M3L	RV ≤ 50V	300% RV	50V < RV ≤ 250V	200% RV	250V < RV ≤ 500V	150% RV	500V < RV ≤ 1000V	130% RV	Class II	X7R/X7S X5R/X6S	RV ≤ 50V	250% RV	50V < RV ≤ 250V	200% RV	250V < RV ≤ 630V	150% RV	630V < RV ≤ 1000V	120% RV
材质		额定电压(RV)	测试电压																								
Class I	C0G/M3L	RV ≤ 50V	300% RV																								
		50V < RV ≤ 250V	200% RV																								
		250V < RV ≤ 500V	150% RV																								
		500V < RV ≤ 1000V	130% RV																								
Class II	X7R/X7S X5R/X6S	RV ≤ 50V	250% RV																								
		50V < RV ≤ 250V	200% RV																								
		250V < RV ≤ 630V	150% RV																								
		630V < RV ≤ 1000V	120% RV																								
4	绝缘阻抗 Insulation Resistance(I.R.)	符合初始规格值。	<p>测试温度 25°C 测试点 在终端之间 测试电压 IF ≤ 500V: 额定电压 IF > 500V: 500V 充电时间 1 分钟 充电/放电电流 最大 50mA</p>																								
5	容值 Capacitance	符合初始规格值。	<p>测量温度 25°C</p> <table border="1"> <thead> <tr> <th colspan="2">材质</th> <th>容值</th> <th>频率</th> <th>电压</th> </tr> </thead> <tbody> <tr> <td rowspan="2">Class I</td> <td rowspan="2">C0G/M3L</td> <td>C ≤ 1000pF</td> <td>1.0 ± 0.1MHz</td> <td>0.5-5.0Vrms</td> </tr> <tr> <td>C > 1000pF</td> <td>1.0 ± 0.1KHz</td> <td>1.0 ± 0.2Vrms</td> </tr> <tr> <td rowspan="2">Class II</td> <td rowspan="2">X7R/X7S X5R/X6S</td> <td>C > 10uF</td> <td>120Hz ± 24Hz</td> <td>0.5V ± 0.1Vrms</td> </tr> <tr> <td>C ≤ 10uF</td> <td>1.0 ± 0.1KHz</td> <td>1.0 ± 0.2Vrms</td> </tr> </tbody> </table>	材质		容值	频率	电压	Class I	C0G/M3L	C ≤ 1000pF	1.0 ± 0.1MHz	0.5-5.0Vrms	C > 1000pF	1.0 ± 0.1KHz	1.0 ± 0.2Vrms	Class II	X7R/X7S X5R/X6S	C > 10uF	120Hz ± 24Hz	0.5V ± 0.1Vrms	C ≤ 10uF	1.0 ± 0.1KHz	1.0 ± 0.2Vrms			
材质		容值	频率	电压																							
Class I	C0G/M3L	C ≤ 1000pF	1.0 ± 0.1MHz	0.5-5.0Vrms																							
		C > 1000pF	1.0 ± 0.1KHz	1.0 ± 0.2Vrms																							
Class II	X7R/X7S X5R/X6S	C > 10uF	120Hz ± 24Hz	0.5V ± 0.1Vrms																							
		C ≤ 10uF	1.0 ± 0.1KHz	1.0 ± 0.2Vrms																							
6	品质因子/ 消散系数 Q or D.F.	符合初始规格值。	<table border="1"> <thead> <tr> <th colspan="2">材质</th> <th>容值</th> <th>频率</th> <th>电压</th> </tr> </thead> <tbody> <tr> <td rowspan="2">Class I</td> <td rowspan="2">C0G/M3L</td> <td>C ≤ 1000pF</td> <td>1.0 ± 0.1MHz</td> <td>0.5-5.0Vrms</td> </tr> <tr> <td>C > 1000pF</td> <td>1.0 ± 0.1KHz</td> <td>1.0 ± 0.2Vrms</td> </tr> <tr> <td rowspan="2">Class II</td> <td rowspan="2">X7R/X7S X5R/X6S</td> <td>C > 10uF</td> <td>120Hz ± 24Hz</td> <td>0.5V ± 0.1Vrms</td> </tr> <tr> <td>C ≤ 10uF</td> <td>1.0 ± 0.1KHz</td> <td>1.0 ± 0.2Vrms</td> </tr> </tbody> </table>	材质		容值	频率	电压	Class I	C0G/M3L	C ≤ 1000pF	1.0 ± 0.1MHz	0.5-5.0Vrms	C > 1000pF	1.0 ± 0.1KHz	1.0 ± 0.2Vrms	Class II	X7R/X7S X5R/X6S	C > 10uF	120Hz ± 24Hz	0.5V ± 0.1Vrms	C ≤ 10uF	1.0 ± 0.1KHz	1.0 ± 0.2Vrms			
材质		容值	频率	电压																							
Class I	C0G/M3L	C ≤ 1000pF	1.0 ± 0.1MHz	0.5-5.0Vrms																							
		C > 1000pF	1.0 ± 0.1KHz	1.0 ± 0.2Vrms																							
Class II	X7R/X7S X5R/X6S	C > 10uF	120Hz ± 24Hz	0.5V ± 0.1Vrms																							
		C ≤ 10uF	1.0 ± 0.1KHz	1.0 ± 0.2Vrms																							

No	测试项目	测试规格	测试方法(参考标准:JIS C 5101, IEC60384)																												
7	温度特性 Temperature Characteristics of Capacitance	<table border="1"> <thead> <tr> <th>材质</th> <th>容值变化</th> </tr> </thead> <tbody> <tr> <td rowspan="2">Class I</td> <td>C0G</td> <td>在±30ppm/°C内变化</td> </tr> <tr> <td>M3L</td> <td>-0.1%/°C~ -0.2%/°C以内</td> </tr> <tr> <td rowspan="4">Class II</td> <td>X5R</td> <td>±15%</td> </tr> <tr> <td>X6S</td> <td>±22%</td> </tr> <tr> <td>X7R</td> <td>±15%</td> </tr> <tr> <td>X7S</td> <td>±22%</td> </tr> </tbody> </table>	材质	容值变化	Class I	C0G	在±30ppm/°C内变化	M3L	-0.1%/°C~ -0.2%/°C以内	Class II	X5R	±15%	X6S	±22%	X7R	±15%	X7S	±22%	<p>测量每个指定温度阶段的电容变化应在 5 分钟后。 在每个步骤达到热平衡后, 按下表所示步骤测量电容。</p> <table border="1"> <thead> <tr> <th>步骤</th> <th>温度</th> </tr> </thead> <tbody> <tr> <td>1</td> <td>参考温度: 25±2°C</td> </tr> <tr> <td>2</td> <td>最低操作温度: ±3°C</td> </tr> <tr> <td>3</td> <td>参考温度: 25±2°C</td> </tr> <tr> <td>4</td> <td>最高操作温度: ±2°C</td> </tr> <tr> <td>5</td> <td>参考温度: 25±2°C</td> </tr> </tbody> </table>	步骤	温度	1	参考温度: 25±2°C	2	最低操作温度: ±3°C	3	参考温度: 25±2°C	4	最高操作温度: ±2°C	5	参考温度: 25±2°C
材质	容值变化																														
Class I	C0G	在±30ppm/°C内变化																													
	M3L	-0.1%/°C~ -0.2%/°C以内																													
Class II	X5R	±15%																													
	X6S	±22%																													
	X7R	±15%																													
	X7S	±22%																													
步骤	温度																														
1	参考温度: 25±2°C																														
2	最低操作温度: ±3°C																														
3	参考温度: 25±2°C																														
4	最高操作温度: ±2°C																														
5	参考温度: 25±2°C																														
8	推力测试 Adhesive Strength of Termination	无终端脱落、陶瓷破损等不良现象。	<p>安装方法 将电容器焊接在测试基板上</p> <p>作用力 5N (0402:2.5N 0201:1N M3L:6N)</p> <p>作用时间 10±1 秒</p> <p>应用方向 在试件中心沿 P.C.板水平方向逐渐施加推力。</p>																												
9	板弯测试 Substrate Bending test	<p>外观 无缺陷或异常。</p> <p>容值变化 [C<1uF] X7R/X5R: ± 10% C0G:± 1% 或 0.5 pF (取较大值) [C≥1uF] X7R/X7S/X7T/X5R: ± 12.5%</p>	<p>安装方法 在 P.C.板上回流焊电容, 并将其弯曲 1mm</p>																												
10	可焊性 Solderability	95%的终端应均匀连续焊接。	<p>焊料 Sn-3.0Ag-0.5Cu(无铅焊料)</p> <p>助焊剂 Isopropyl alcohol Rosin 25% solid solution.</p> <p>焊锡温度 245±5°C</p> <p>停留时间 2±0.5s.</p> <p>焊锡位置 直到两端都完全浸湿</p>																												

No	测试项目	测试规格	测试方法(参考标准:JIS C 5101, IEC60384)															
11	耐焊接热 Resistance to Soldering Heat	外观 容值 Q or D.F. I.R. 耐电压 无缺陷或异常。 请参考单颗规格书 请参考单颗规格书 请参考单颗规格书 无缺陷或异常	<p>预处理 热处理:在 150+0/-10°C 下热处理 1 小时, 然后在室温下静置 24±2 小时, 然后测量。</p> <p>测试方法 焊锡浴法</p> <p>焊料种类 Sn-3.0Ag-0.5Cu(Lead Free Solder)</p> <p>测试温度 260±5°C</p> <p>测试时间 10±1s</p> <p>预热温度 110°C到 140°C</p> <p>预热时间 1 分钟</p> <p>后处理 在室温下静置 24±2 小时, 然后测量。(非处理)</p>															
12	温度循环 Temperature Cycle	外观 容值 Q or D.F. I.R. 无缺陷或异常。 请参考单颗规格书 请参考单颗规格书 请参考单颗规格书	<p>安装方法 将电容器焊接在测试基板上</p> <p>预处理 热处理:在 150+0/-10°C 下热处理 1 小时, 然后在室温下静置 24±2 小时, 然后测量。</p> <p>温度循环 5 个周期</p> <table border="1"> <thead> <tr> <th>步骤</th> <th>温度</th> <th>时间</th> </tr> </thead> <tbody> <tr> <td>1</td> <td>最低温度±3°C</td> <td>30±3min</td> </tr> <tr> <td>2</td> <td>室温</td> <td>2~5min</td> </tr> <tr> <td>3</td> <td>最高温度±3°C</td> <td>30±3min</td> </tr> <tr> <td>4</td> <td>室温</td> <td>2~5min</td> </tr> </tbody> </table> <p>后处理 在室温下静置 24±2 小时, 然后测量 (非处理)</p>	步骤	温度	时间	1	最低温度±3°C	30±3min	2	室温	2~5min	3	最高温度±3°C	30±3min	4	室温	2~5min
步骤	温度	时间																
1	最低温度±3°C	30±3min																
2	室温	2~5min																
3	最高温度±3°C	30±3min																
4	室温	2~5min																
13	恒温恒湿 High Temperature High Humidity	外观 容值 Q or D.F. I.R. 无缺陷或异常。 请参考单颗规格书 请参考单颗规格书 请参考单颗规格书	<p>安装方法 将电容器回流焊焊接在测试基板上</p> <p>预处理 热处理:在 150+0/-10°C 下热处理 1 小时, 然后在室温下静置 24±2 小时, 然后测量。</p> <p>测试温度 40±2°C</p> <p>测试湿度 90%RH to 95%RH</p> <p>测试时间 500±24 小时</p> <p>测试电压 额定电压 (不超过 630V)</p> <p>充电/放电电流 最大 50mA</p> <p>电压调节 “在测试温度和电压下对电容器进行电压处理 1 小时后”, 在测量前将电容器置于环境条件下 24±2 小时, 使用此测量值作为初始值。</p>															

No	测试项目	测试规格	测试方法(参考标准:JIS C 5101, IEC60384)
14	耐久测试 Life	外观 无缺陷或异常。 容值 请参考单颗规格书 Q or D.F. 请参考单颗规格书 I.R. 请参考单颗规格书	<p>安装方法 将电容器焊接在测试基板上</p> <p>预处理 热处理:在 150+0/-10°C 下热处理 1 小时, 然后在室温下静置 24±2 小时, 然后测量。</p> <p>测试温度 最高工作温度 ±3°C</p> <p>测试时间 1000±12 小时</p> <p>测试电压 请参考单颗规格书</p> <p>充电/放电电流 最大 50mA</p> <p>电压调节 “在测试温度和电压下对电容器进行电压处理 1 小时后”, 在测量前将电容器置于环境条件下 24±2 小时, 使用此测量值作为初始值。</p>

产品包装

载带卷盘包装是目前最常见的包装方式，一个直径为 180mm (7") 的卷轴可包含 1000~20000 个电容,也可按照客户的要求进行卷盘包装。

1. 纸带尺寸

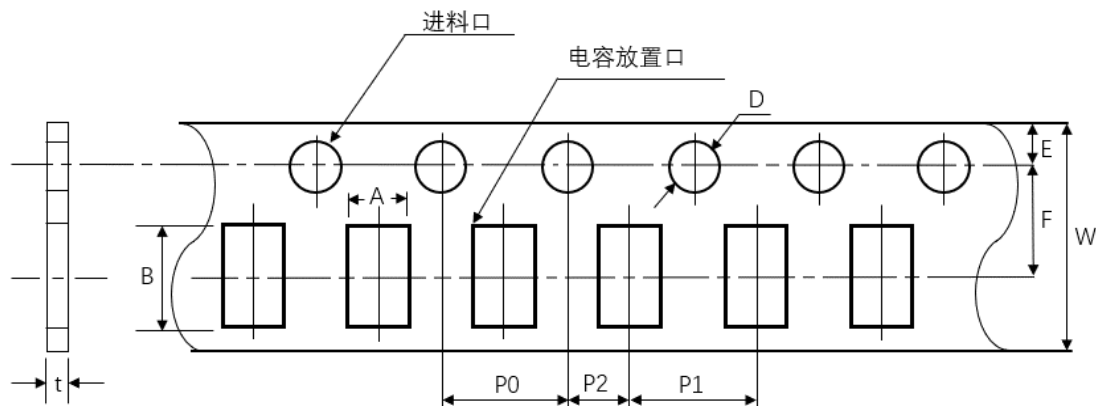

	01005 (0402)	0201 (0603)	0402 (1005)	0603 (1608)	0805 (2012)	1206 (3216)
P1	2.00±0.05(1.0 ±0.05)			4.00±0.10		
P0	4.00±0.10			4.00±0.10		
P2	2.00±0.05			2.00±0.05		
A	0.25±0.02	0.38±0.03	0.62±0.05	1.00±0.01	1.55±0.10	2.05±0.10
B	0.46±0.02	0.68±0.03	1.12±0.05	1.90±0.10	2.30±0.10	3.60±0.10
W	8.00±0.30			8.00±0.30		
E	1.75±0.10			1.75±0.10		
F	3.50±0.05			3.50±0.05		
D	φ1.50+0.10/-0.03			φ1.50+0.10/-0		
t	0.25±0.02	0.35±0.03	0.60±0.05	1.1Below		

2. 塑胶袋尺寸

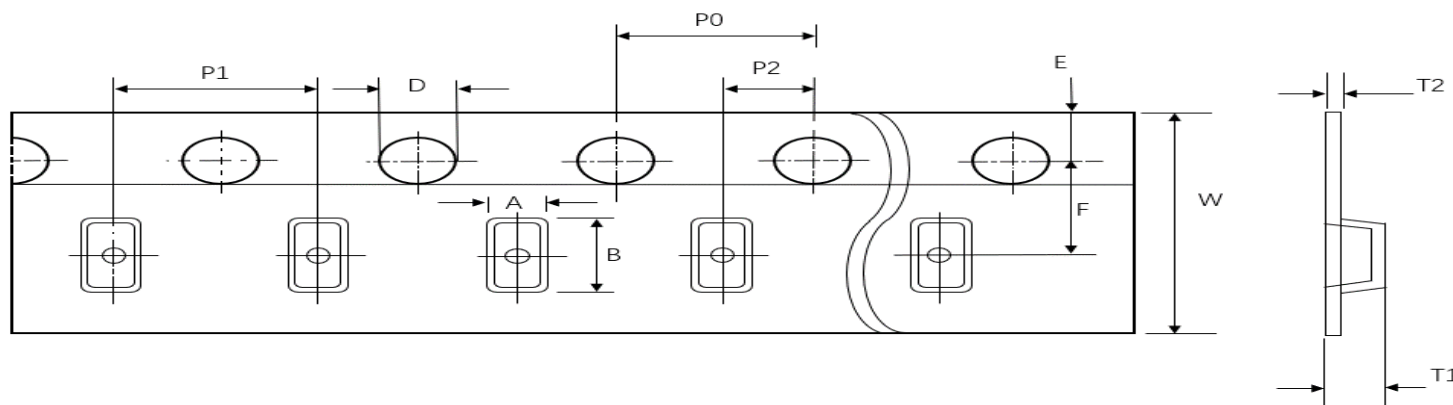

	0805 (2012)	1206 (3216)	1210 (3225)	1808 (4520)	1812 (4532)	2220 (5750)
P0	4.00±0.10	4.00±0.10	4.00±0.10	4.00±0.10	4.00±0.10	4.00±0.10
P1	4.00±0.10	4.00±0.10	4.00±0.10	4.00±0.10	8.00±0.10	8.00±0.10
P2	2.00±0.05	2.00±0.05	2.00±0.05	2.00±0.05	2.00±0.05	2.00±0.05
A	< 1.80	< 2.50	< 3.20	< 2.50	< 3.90	< 6.80
B	< 2.70	< 4.00	< 4.00	< 5.30	< 5.30	< 6.50
W	8.00±0.20	8.00±0.20	8.00±0.20	12.00±0.20	12.00±0.20	12.00±0.20
E	1.75±0.10	1.75±0.10	1.75±0.10	1.75±0.10	1.75±0.10	1.75±0.10
F	3.5±0.05	3.5±0.05/5.50±0.05	3.5±0.05/5.50±0.05	5.50±0.05	5.50±0.05	5.50±0.05
D	1.5 (+0.1/-0.0)	1.5 (+0.1/-0.0)	1.5 (+0.1/-0.0)	1.5 (+0.1/-0.0)	1.5 (+0.1/-0.0)	1.5 (+0.1/-0.0)
T1	2.5 max.	2.5 max.	3.5 max.	2.5 max.	3.0 max.	3.1 max.
T2	0.23±0.05	0.23±0.05/0.95±0.05	0.23±0.05	0.30±0.1	0.30±0.1	0.30±0.1

3. 圆盘尺寸

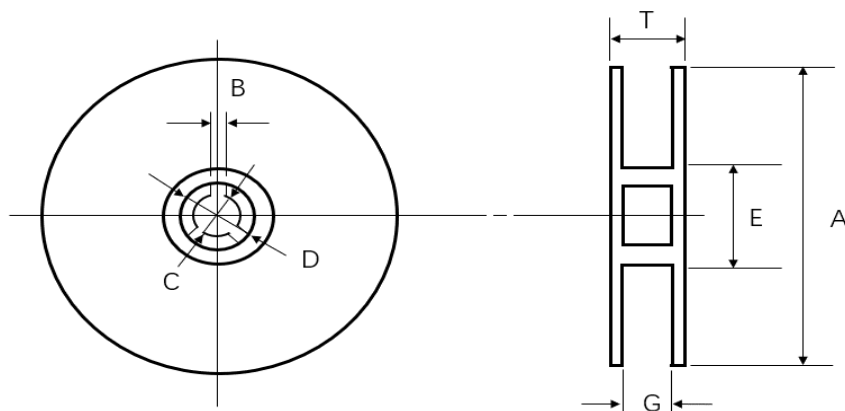

圆盘尺寸	A (mm)	B (mm)	C (mm)	D (mm)	E (mm)	G (mm)	T (mm)
7"Reel	$\Phi 178 \pm 2.0$	2.0 ± 0.5	$\Phi 13 \pm 1.0$	$\Phi 21 \pm 0.8$	$\Phi 50$ 或更大	10 ± 1.0	13 ± 1.0

4. 卷装带使用说明

成品在使用时，上带（膜）以 $300 \pm 10 \text{ mm/min}$ 的速度， $165^\circ \sim 180^\circ$ 的角度(如下图示)，剥离强度在 $0.1\text{N} \sim 0.7\text{N}$ ($10\text{g.f} \leq \text{剥离力} \leq 70\text{g.f}$)。

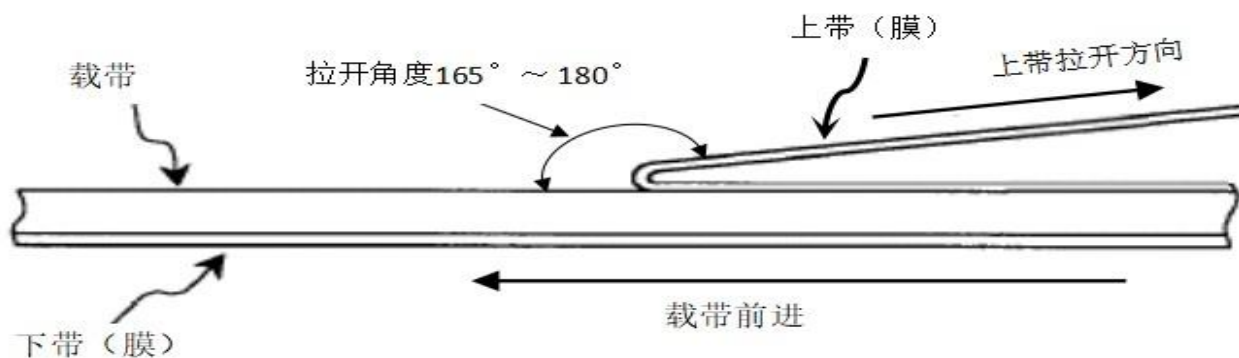

使用注意事项

多层片式瓷介电容器(MLCC)在超出本承认书或相关说明书中所述使用频率的恶劣工作环境,或外界机械力超压作用下,电容有可能会短路、开路,或者有可能会冒烟、燃烧甚至爆炸,所以在使用的时候,首先应考虑按本承认书的有关说明来进行,如有不明之处,请联系我们技术部、品管部或生产部。

1.焊接时焊料的用量

A.焊料过多这样会因电容端头压力过大而可能引起电容受损。



B.焊料太少固定力量不足,可能会引起电容芯片与线路接触不良。



2.推荐焊料用量:

A.回流焊接的最佳焊料用量

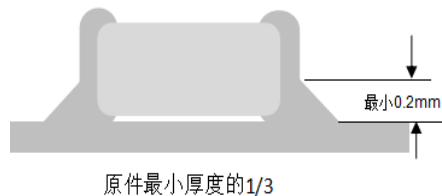

B.波峰焊接的最佳焊料用量

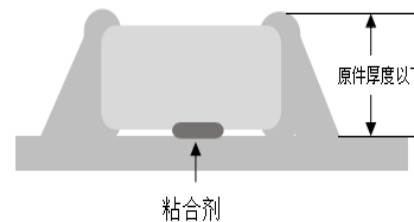

C.使用烙铁返修时的最佳焊料用量

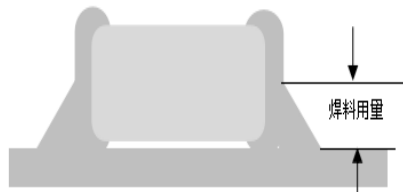

3.推荐焊接温度曲线图:

焊接模式	≤0402	0603	0805	1206	≥1210
回流焊接	所有规格	> 1.0 μF 105 以上容值	> 2.2 μF 225 以上容值	> 4.7 μF 475 以上容值	所有规格
回流/波峰焊接		≤ 1.0 μF 105 及以下容值	≤ 2.2 μF 225 及以下容值	≤ 4.7 μF 475 及以下容值	

回流焊接

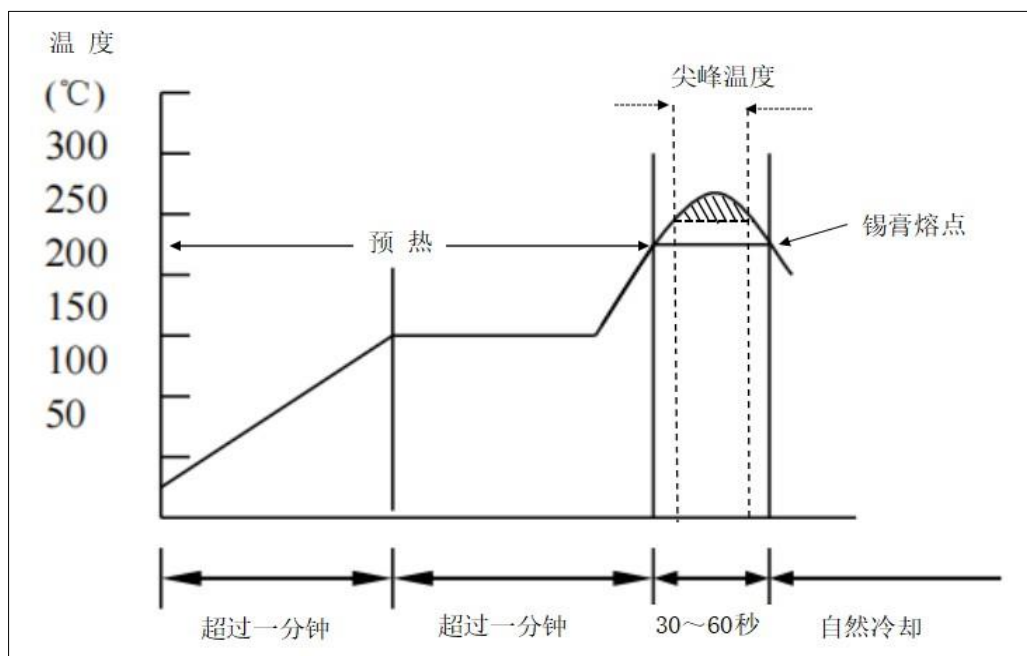

焊锡类型	Pb-Sn 焊接	无铅焊接
尖峰温度	230°C ~ 250°C	240°C ~ 260°C
尖峰时间	3s ~ 10s	3s ~ 10s

波峰焊接

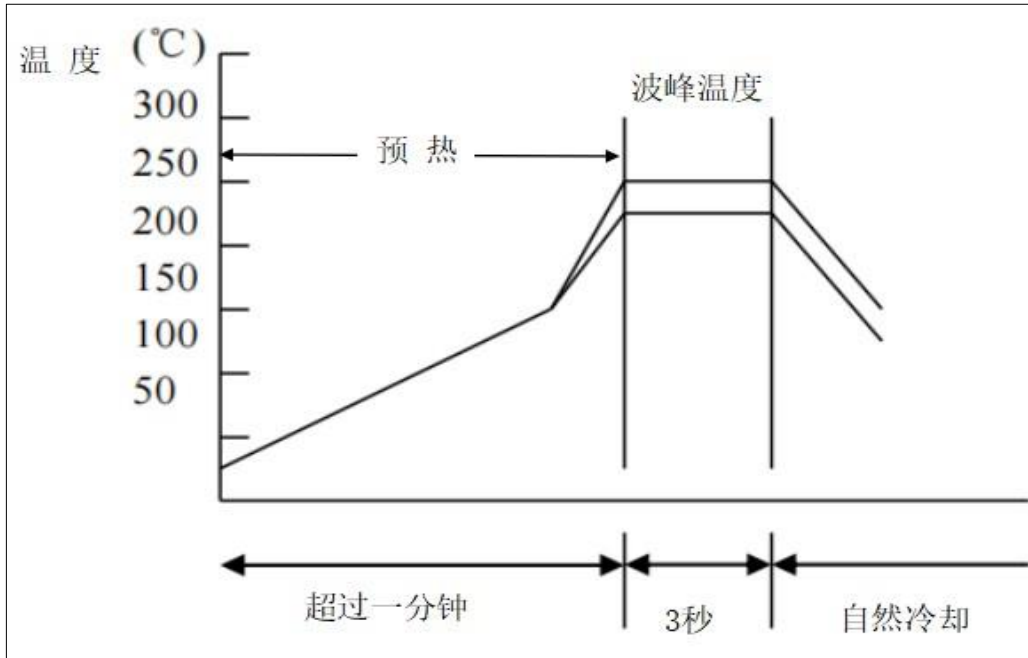

焊锡类型	Pb-Sn 焊接	无铅焊接
尖峰温度	230°C ~ 260°C	240°C ~ 270°C
尖峰时间	3s 内	3s 内

手工焊接

手工焊接很容易因为电容局部受热不均而引起瓷体微裂或局部爆裂现象。因此,使用电烙铁手工焊接时应仔细操作,并对电烙铁的尖端的选择和尖端温度控制应多加小心.

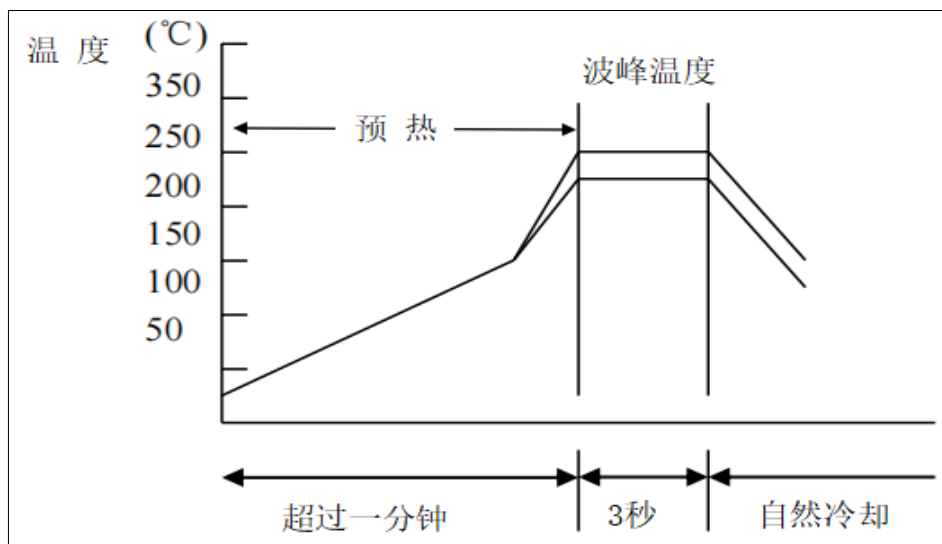

预热	烙铁头温度	烙铁功率	烙铁头直径	焊接时间	锡膏量	注意事项
$\Delta \leq 130^{\circ}\text{C}$	$\leq 350^{\circ}\text{C}$	$\leq 20\text{W}$	建议 1mm	$\leq 3\text{s}$	$\leq 1/2$ 电容高度	烙铁头勿直接接触陶瓷本体

版本	修订日期	修订内容叙述
CSA-S 01	2023/2/24	初始发行
CSA-S 02	2023/6/09	1.更新容值范围 2.更新包装数量
CSA-S 03	2023/12/01	1.更新容值范围图 2.新增 M3L 的测试规格 3.新增焊接模式容值表【P19】