

MMS/MMT/MMCX series

R209 / R210 / R110

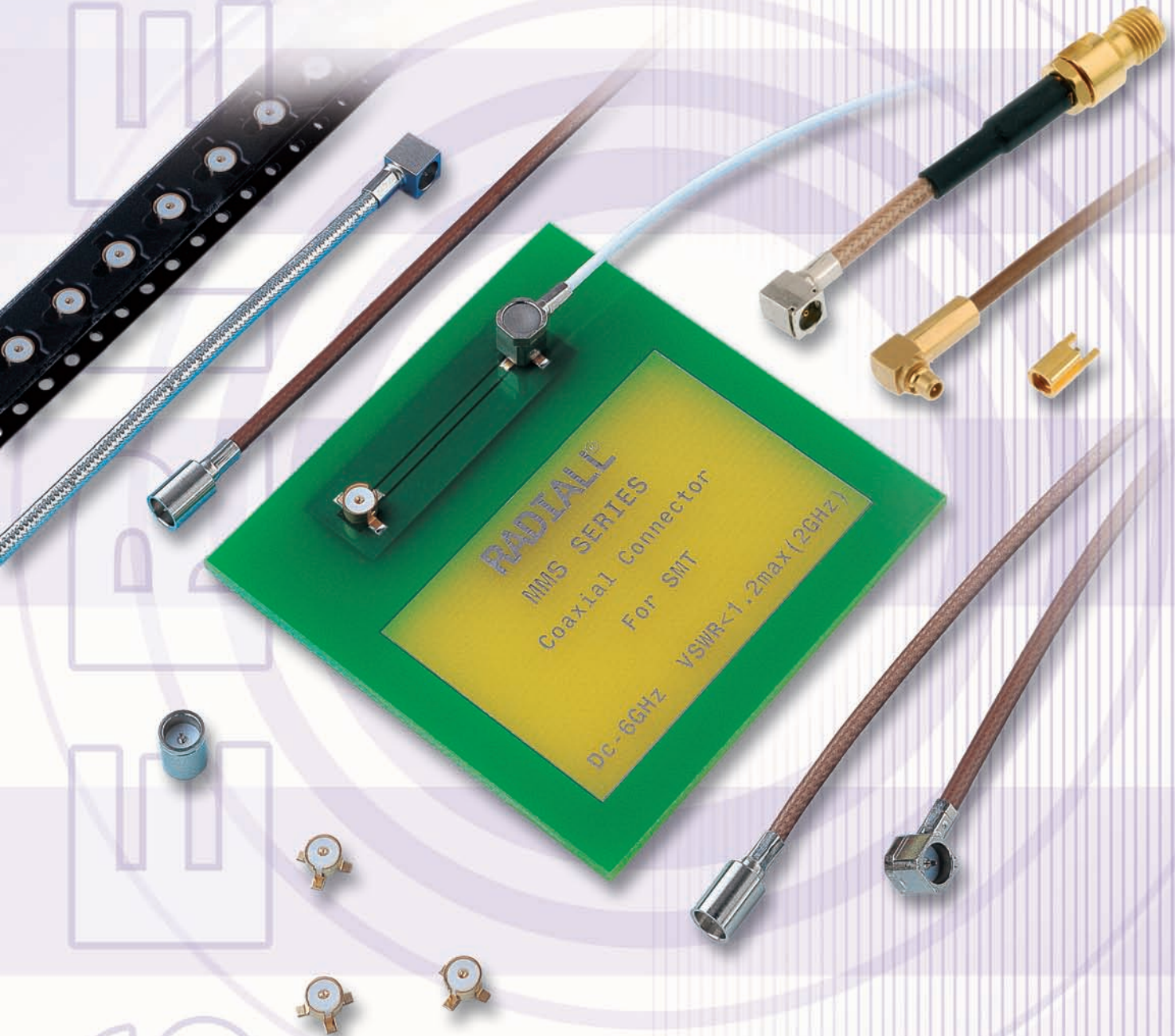

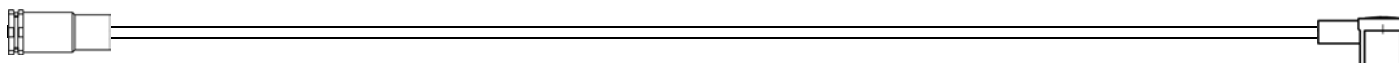

	PAGE
MMS/MMT	
Introduction.....	4
General.....	5
Characteristics MMS.....	6
Characteristics MMT.....	7
Connectors.....	8-9
Plugs.....	10
Standard cable assemblies.....	11-12
Receptacles.....	13
Adapters.....	14
Measurement cable assemblies.....	15
Extraction tool.....	15
Receptacle packaging.....	16
Custom cable assemblies.....	17
Video shadow and soldering pattern of the receptacle.....	18
Suction procedure for receptacle.....	18
Radiall recommended SMT procedure.....	19
MMCX	
General.....	20
Interface.....	21
Characteristics.....	22
Plugs.....	23
Receptacles.....	24
Receptacle packaging.....	25
Assembly instruction.....	26-28
Video shadow and soldering pattern.....	29
Radiall recommended SMT procedure.....	30

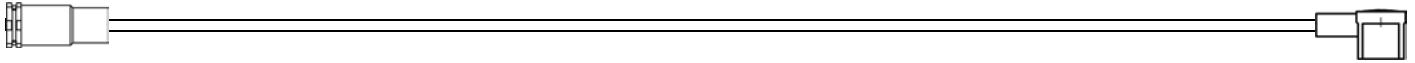

RADIALl has designed a complete range of microminiature coaxial connectors, dedicated to **Surface Mount Technology (SMT)**.

Better than a simple SMT version of standard connector, **MMS** and **MMT** series were the first coaxial connectors fully designed for SMT applications.

Due to its optimized design, **MMS** and **MMT** range benefit from the following advantages:

- **Design adapted to automatic placement**

The assymetric footprint of the **MMS** and **MMT** connectors allows video micro-positioning using the component's shadow to analyse its placement.

MMS and **MMT** connectors stand on three pliable legs. This design guarantees the receptacle stability after the placement. It allows it to absorb by elastic bending of the legs, the pressure of the positioning and placement mechanism.

- **A geometry suited to automated picking**

The plain upper surface of **MMS** and **MMT** receptacle facilitates vacuum picking of the component at the exit of the automated distribution system.

The geometry allows the use of numerous pneumatic nozzles with various diameters.

- **Optimization of soldering procedure**

MMS and **MMT** connectors materials used resist, without damage, the rapid elevation of temperature (to 270°C) during the short time of the solder reflow in an infra-red oven.

- **Packaging**

The **MMS** and **MMT** connectors are packaged on tape and reels containing either 100, 500 or 3 000 receptacles.

The unit cavity geometry is designed for a perfect presentation of the component. The bottom of the cavity is pierced. This hole facilitates the suction of the component, avoiding the adherence effect and allows the use of a through hole for a push rod.

- **360° cable rotation**

The **MMS** and **MMT** snap-on mating system ensures a correct positive connection each time and all **MMS** and **MMT** connectors (plugs + receptacles) have a design which allows a 360° rotation of the pair when mated.

- **MMS vs MMT**

MMS and **MMT** connectors are dedicated to similar application.

Nevertheless the choice between these to standard will be driven by the following characteristics:

	MMS	MMT	Comment
Durability (mating cycle)	50	500	It is the main difference between these two series. MMS is dedicated for application wich requires only few mating/unmating cycles. MMT provide stronger retention force while allowing more manipulation.
Frequency range	50 Ohms DC-6 GHz 75 Ohms DC-1 GHz	50 Ohms DC-8 GHz 75 Ohms DC-1 GHz	Both series are fully optimized for either wireless phone frequency range or mobile computing such as bluetooth, Wifi and Wimax.
Mated height	5.2 mm	6.8 mm	

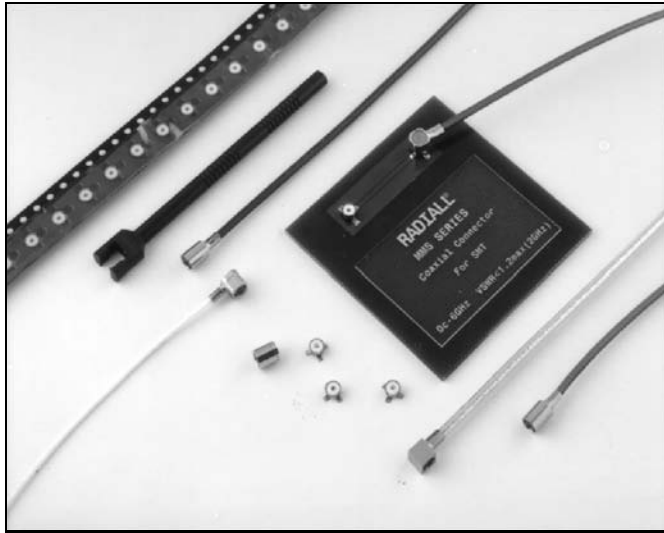
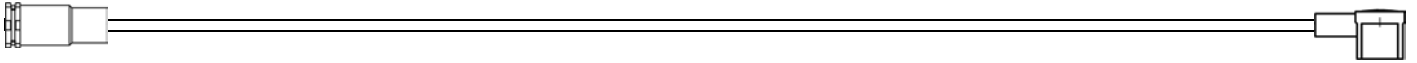

	MMS	MMT
50 Ω	DC - 6 GHz	DC - 8 GHz
75 Ω	DC - 1 GHz	DC - 1 GHz

GENERAL

- Low profile coaxial connectors
- Surface-mount receptacle (SMT)
- Fully compatible with automated pick and place machines
- Snap-on mating
- High RF performance
- 360° cable rotation

APPLICATIONS

- Base stations and hand-sets for:
 - cellular telephones
 - cordless telephones
- Satellite reception terminals (GPS...)
- Instrumentation
- Wireless datacom networks
- Automated payment systems
- Videocommunications
- Other general electronics

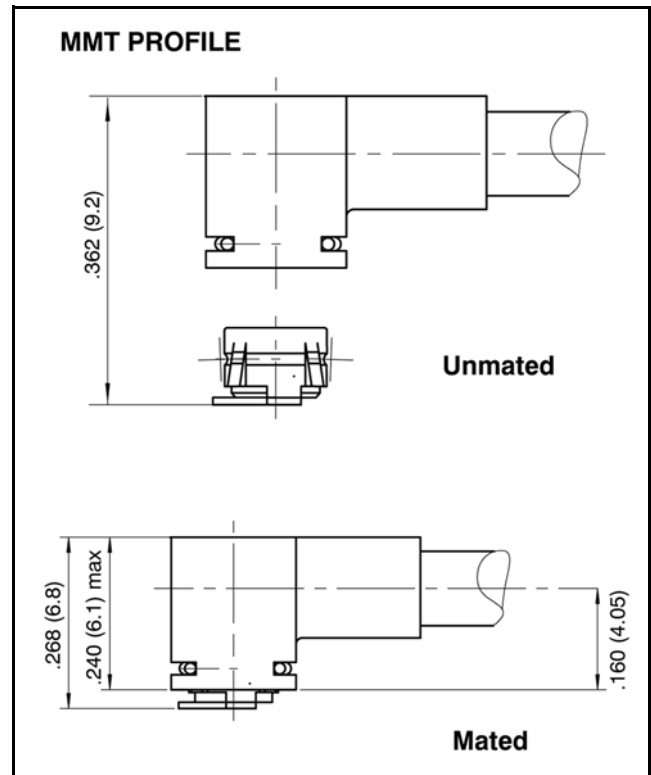
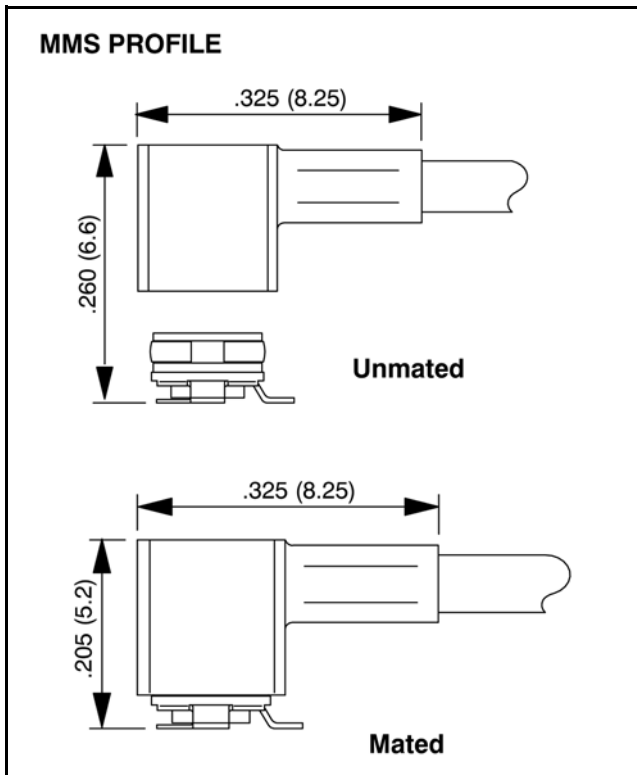

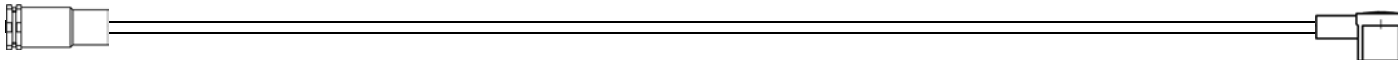

	TEST STANDARD	VALUES/REMARKS
--	---------------	----------------

ELECTRICAL CHARACTERISTICS

	TEST STANDARD	VALUES/REMARKS
Impedance		50 Ω 75 Ω
Frequency range		DC-6 GHz DC-1 GHz
Typical V.S.W.R. (mated pair)	IEC 1169-1	1.05 at 1 GHz 1.15 at 2.5 GHz 1.35 at 6 GHz
Insertion loss	IEC 1169-1	0.2 dB at 2 GHz
RF leakage (mated pair)	MIL STD 1344 method 3008	-50 dB at 500 MHz -45 dB at 1 GHz -40 dB at 2 GHz
Outer contact resistance	NF-C 93050 (I = 40 mA peak)	5 MΩ max
Center contact resistance	NF-C 93050 (I = 40 mA peak)	15 MΩ max
Insulation resistance	IEC 1169-1	500 MΩ min (under 250 V RMS)
Working voltage		50 V RMS
Testing voltage (V RMS)	IEC 1169-1	Ø 1 mm: 250 ; Ø 2 mm: 500
Maximum admissible power		40 W at 1 GHz / 20°C / V.S.W.R. = 1

MECHANICAL CHARACTERISTICS

Durability	IEC 1169-1	50 matings
Force to engage	IEC 1169-1	7 N avg
Force to disengage	IEC 1169-1	5.5 N avg
Shocks (drop test)	IEC 68-2-27	50 g/11 ms ; 3 shocks/axis/way
Random vibrations	Général Motors spec.	Sine waves 5 to 1000 Hz 3 to 30g - 1 H/axis
Bumps (mechanical shocks)	IEC 68-2-29	25 g/6 ms 1000 bumps/axis/way
Cable retention force	IEC 1169-1	Ø 1 mm: 20 N ; Ø 2 mm: 35 N
Solderability	IEC 68-2-54	Passed

ENVIRONMENTAL CHARACTERISTICS

Temperature range		-40°C / +90°C
Climatic cycles	GAM T 13	48 H at 70°C - 24 H at 40°C/93% -36 H at -25°C

MATERIALS

Bodies plugs / in series adapters	Die cast zinc / brass
Bodies receptacles	Phosphor bronze
Center contact male	Brass
female	Beryllium copper
Insulator	PTFE

PLATINGS

Bodies plugs, in series adapters	Nickel
Bodies receptacles	Gold
Center contact male	Nickel
female	Gold

POWER RATING Example: P = 23 W at F= 1.8 GHz, T = 40°C, V.S.W.R. = 1.1

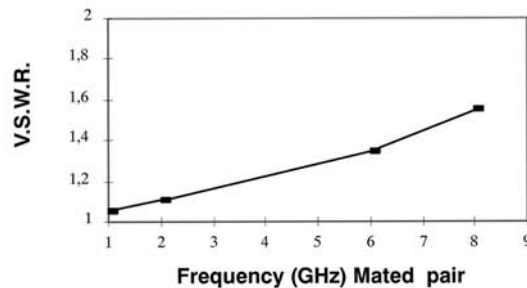
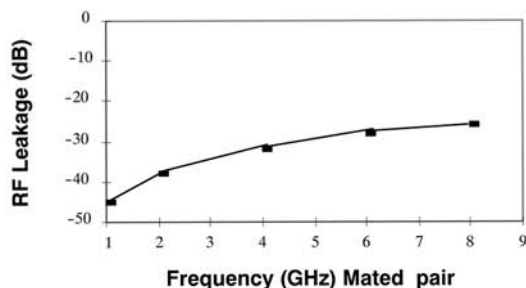

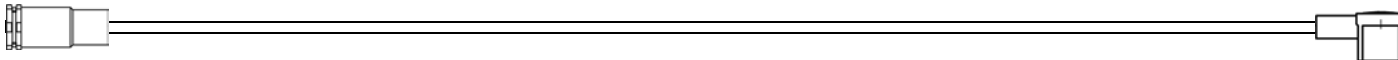

	TEST STANDARD	VALUES/REMARKS	
--	---------------	----------------	--

ELECTRICAL CHARACTERISTICS

Impedance		50 Ω	75 Ω
Frequency range		DC – 8 GHz	DC – 1 GHz
Typical V.S.W.R. (mated pair)	IEC 1169-1	1.05 at 1 GHz 1.10 at 2.5 GHz 1.15 at 6 GHz	
Insertion loss	IEC 1169-1	≤ 0.2 √ F (GHz)	
RF leakage (mated pair)	IEC 1726	-42 dB at 500 MHz -38 dB at 1 GHz -30 dB at 3 GHz	
Outer contact resistance	IEC 1169-1 (I=40 mA eff.)	Initial : 2.5 mΩ max	Final : 12.5 mΩ max
Center contact resistance	IEC 1169-1 (I=40 mA eff.)	Initial : 5 mΩ max	Final : 15 mΩ max
Insulation resistance	IEC 1169-1	≥ 5000 MΩ under 500 Vcc	
Working voltage		170 V eff.	
Testing voltage	IEC 1169-1	500 V eff.	

MECHANICAL CHARACTERISTICS

Durability	IEC 1169-1	500 matings	
Force to engage/disengage	IEC 1169-1	Ins ≤ 18 N	Ext > 7 N
Shocks	IEC 68-2-27	passed	
Vibrations	IEC 68-2-6	passed	
Bumps	IEC 68-2-29	passed	
Cable retention force	IEC 1169-1	∅ 2 mm = 20 N - ∅ 2.6 mm = 60 N	
Solderability	IEC 68-2-29	passed	

ENVIRONMENTAL CHARACTERISTICS

Temperature range		55°C / 100°C	
Damp heat	IEC 68-23	passed	
Thermal shocks	IEC 68-2-14 / Test NA	passed	

MATERIALS

Plugs body / in-series adaptor	Die cast zinc / brass
Receptacles body	CuSn9p
Plugs center contact	Cube2
Receptacles center contact	Brass
Insulators	PTFE

PLATINGS

Plugs body / in-series adapter	Nickel / BBR*
Receptacles body	Gold
Plugs center contact	Gold
Receptacles center contact	Gold

POWER RATING

Example: P = 23 W at F= 1.8 GHz, T = 40°C, V.S.W.R. = 1.1

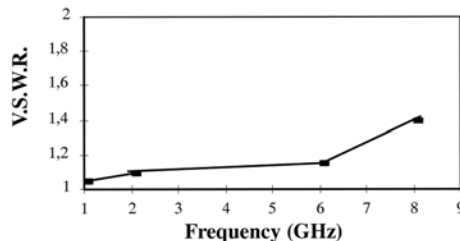
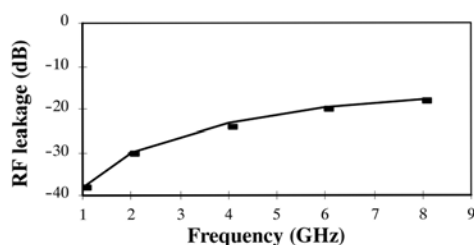

* BBR Bright Bronze Radiall

All dimensions are given in mm

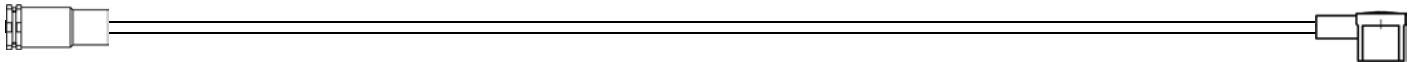

Series	Connector type	1 / 50 / S		2 / 50 / S		2 / 50 / D	
		Crimp	Crimp	Solder	Clamp	Crimp	Clamp
SSMB	STRAIGHT PLUG		R203 073 000(020•)				
	R/A PLUG		R203 173 000(020•)				
	BULKHEAD STRAIGHT JACK		R203 313 000				
	BULKHEAD R/A JACK		R203 373 000•				
SSMC	STRAIGHT PLUG	R202 070 000	R202 073 000•				
	R/A PLUG		R202 173 000•				
MMS	STRAIGHT PLUG		R209 080 000			R209 081 000•	
	R/A PLUG		R209 353 000			R209 355 000	
MMT	R/A PLUG		R210 153 000			R210 155 000	
MCX	STRAIGHT PLUG	R113 070 000(020•)	R113 081 000(020)			R113 080 000•	
	R/A PLUG		R113 181 000(020)	R113 161 000(020)			
	STRAIGHT JACK		R113 236 000•(020)				
	BULKHEAD STRAIGHT JACK		R113 306 000(020•)				
Coaxial terminals	STRAIGHT - 2 legs	R280 278 300	R280 280 000(020)	R280 221 000(020•)			
	STRAIGHT - 4 legs		R280 282 000		R280 281 000		
	R/A - 2 legs			R280 219 000(020•)			
	R/A - 4 legs		R280 292 000		R280 291 000		
SMA	STRAIGHT PLUG		R125 069 000/R124 069 120(123)				R125 002 200•
	R/A PLUG		R125 170 402•				R125 163 200•
	STRAIGHT JACK		R125 231 000•(001)				
	FLANGE STRAIGHT JACK		R125 270 000•/R124 271 120(123)				
	TRUNC. FLANGE STRAIGHT JACK					R125 270 000•(001•)	
	BULKHEAD STRAIGHT JACK		R124 310 020(023)				
SMB	STRAIGHT PLUG		R114 073 000		R114 003 000(020•)		
	R/A PLUG		R114 183 000(020•)		R114 163 000(020•)	R114 174 000•	
	STRAIGHT JACK		R114 237 000		R114 203 000		R114 304 000•(420•)
	BULKHEAD STRAIGHT JACK		R114 311 000		R114 303 000		
SMC	STRAIGHT PLUG		R112 073 000(020)		R112 003 000(020•)	R112 073 000(020•)	R112 003 000(020•)
	R/A PLUG		R112 183 000(020)		R112 163 000	R112 183 000(020)	R112 163 000
	STRAIGHT JACK		R112 237 000•		R112 203 000(120•)	R112 237 000•	R112 203 000(120•)
	BULKHEAD STRAIGHT JACK		R112 311 000•		R112 303 000	R112 311 000•	R112 303 000
BMA	BULKHEAD PANEL SEAL STRAIGHT PLUG		R128 082 001•				
	FLOATING STRAIGHT JACK		R128 232 001•				
	FLOATING FLANGE STRAIGHT JACK		R128 250 001				
Microcltic	STRAIGHT PLUG	R205 070 000	R205 071 000				
	R/A PLUG		R205 181 000				
	STRAIGHT JACK	R205 240 000•	R205 241 000				
BNC	STRAIGHT PLUG				R141 003 000		
	R/A PLUG				R141 153 000		
	FLANGE STRAIGHT JACK		R141 285 000•		R141 253 000		
	BULKHEAD STRAIGHT JACK				R141 323 000		R141 301 000•
mQ	STRAIGHT PLUG				R225 003 000•		
	FLANGE STRAIGHT JACK				R225 253 000		
	BULKHEAD STRAIGHT JACK				R225 303 000•		
N	STRAIGHT PLUG		R161 071 000				
	FLANGE STRAIGHT JACK		R161 281 000			R161 281 000	
	BULKHEAD PANEL SEAL STRAIGHT JACK		R161 309 000(200)			R161 309 000(200)	

• Manufactured upon request. Please consult us.

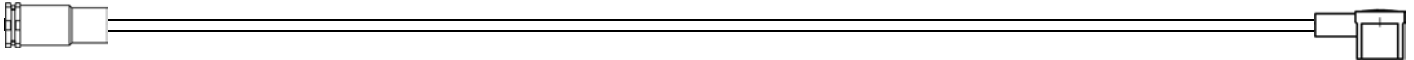

Series	Connector type	2,6 / 50 / S			2,6 / 50 / D	
		Crimp	Solder	Clamp	Crimp	Clamp
SSMA	STRAIGHT PLUG	R121 072 000				
	R/A PLUG	R121 172 000				
	STRAIGHT JACK	R121 236 000				
SSMB	STRAIGHT PLUG	R203 075 000 (020)			R203 076 030*	
	R/A PLUG	R203 175 000 (020)				
	BULKHEAD STRAIGHT JACK	R203 315 000				
SSMC	STRAIGHT PLUG	R202 075 000				
	R/A PLUG	R202 175 000				
SBMA	BULKHEAD STRAIGHT PLUG				R108 084 001*	
	FLOATNG FLANGE STRAIGHT JACK				R108 264 001*	
MMT	STRAIGHT PLUG	R210 087 000				
	R/A PLUG	R210 157 000			R210 158 000	
MCX	STRAIGHT PLUG	R113 082 000 (020)			R113 083 000(020)	
	R/A PLUG	R113 182 000 (020)			R113 183 000(020)	
	STRAIGHT JACK	R113 240 000 (020)			R113 241 000*(020*)	
	BULKHEAD STRAIGHT JACK	R113 310 000 (020)			R113 311 000*(020*)	
Coaxial terminals	STRAIGHT - 2 legs	R280 280 100 (120)	R280 222 000(020)		R280 280 200*	
	STRAIGHT - 4 legs	R280 284 000		R280 283 000	R280 283 000	
	R/A - 2 legs	R280 294 308	R280 222 200(020)			
	R/A - 4 legs	R280 294 000		R280 293 000		R280 293 000
SMA	STRAIGHT PLUG	R125 072 000(001)/R124 071 120(123)			R125 072 008	R124 072 220(223)
	R/A PLUG	R125 172 000(001)/R124 172 120(123)			R125 174 000*	R124 174 120(123)
	STRAIGHT JACK	R125 236 000(001)/R124 236 120(123)			R125 233 000*(001*)	R124 233 120(123)
	FLANGE STRAIGHT JACK	R125 272 000(001)/R124 272 120(123)				R124 274 120(123)
	BULKHEAD PANEL SEAL STRAIGHT JACK	R125 303 000(001)/R124 312 120(123)			R125 304 000*(001*)	R124 313 120(123)
SMB	STRAIGHT PLUG	R114 082 000(020)		R114 005 000(120)	R114 083 000(020*)	
	R/A PLUG	R114 187 000(020)		R114 165 000	R114 182 000	
	STRAIGHT JACK	R114 238 000(120)		R114 205 000	R114 244 420*	
	BULKHEAD STRAIGHT JACK	R114 313 000(020)		R114 305 000	R114 315 000*	
SMC	STRAIGHT PLUG	R112 082 000(120)		R112 005 000(120)	R112 083 000*	
	R/A PLUG	R112 187 000		R112 165 000	R112 182 000	
	STRAIGHT JACK	R112 238 000(120)	R112 205 120	R112 205 000		
	BULKHEAD STRAIGHT JACK	R112 313 000		R112 305 000		
BMA	BULKHEAD STRAIGHT PLUG	R128 083 000(001)			R128 084 827	
	BULKHEAD PANEL SEAL STRAIGHT PLUG	R128 085 000(001)				
	FLOATING STRAIGHT JACK	R128 233 000(001)			R128 234 827	
	FLOATING FLANGE STRAIGHT JACK	R128 263 000(001)			R128 264 827	
	BULKHEAD STRAIGHT JACK	R128 313 000(001)				
Microclic	STRAIGHT PLUG	R205 074 000				
	STRAIGHT JACK	R205 244 000				
BNC	STRAIGHT PLUG	R141 075 000		R141 004 000		
	R/A PLUG	R141 175 000		R141 154 000		
	FLANGE STRAIGHT JACK	R141 290 200		R141 254 000		
	BULKHEAD STRAIGHT JACK	R141 306 000		R141 324 000		
mQ	STRAIGHT PLUG			R225 004 000		
	FLANGE STRAIGHT JACK			R225 254 000		
	BULKHEAD STRAIGHT JACK			R225 304 000		
N	STRAIGHT PLUG	R161 072 000		R161 004 000	R161 072 000	R161 004 000
	R/A PLUG	R161 181 000			R161 181 300	
	FLANGE STRAIGHT JACK	R161 281 300		R161 252 000	R161 281 300	R161 252 000
	BULKHEAD PANEL SEAL STRAIGHT JACK	R161 311 200(300)		R161 321 000 R161 322 000	R161 311 200(300)	R161 321 000 R161 322 000

ATTENTION: this guide is intended as an information and does not include all series P/N.

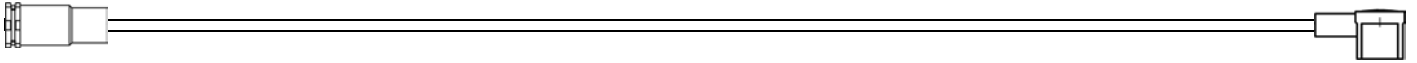

STRAIGHT PLUGS CRIMP TYPE FOR FLEXIBLE CABLES

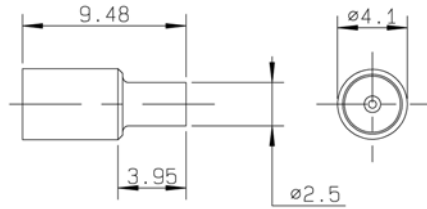

Fig. 1



Fig. 2

Series	Cable group	Part number	Fig	Imp. (Ω)	Dimensions (mm)		Captive center contact	Finish
					A	B		
MMS	2 / 50 / S	R209 080 000	1	50	2	0,6	Yes	Nickel
	2 / 50 / D	R209 081 000*				0,3		
	2 / 75 / S	R209 082 000*				0,6		
MMT	2.6 / 50 / S	R210 087 000	2	50			Yes	Nickel

RIGHT ANGLE PLUGS CRIMP TYPE FOR FLEXIBLE CABLES

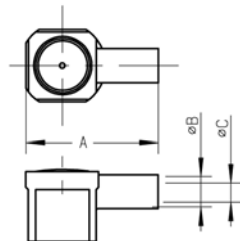

Fig. 1

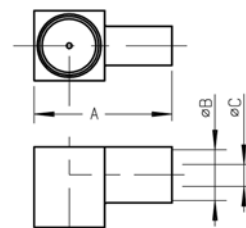

Fig. 2

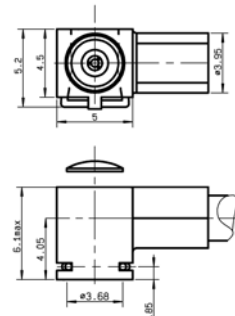
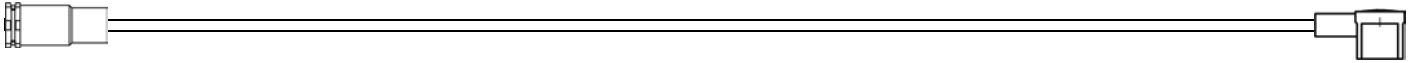

Fig. 3

Series	Cable group	Part number	Fig.	Imp. (Ω)	Dimensions (mm)			Captive center contact	Finish
					A	B	C		
MMS	1 / 50 / S	R209 351 020	1	50	7,15	1,28	0,65	yes	Nickel
	2 / 50 / S	R209 353 000			8,25	2	1,1		
	2 / 50 / D	R209 355 000	2		8,06	2,25	1,4		
	2 / 75 / S	R209 353 000	1		8,25	2	1,1		
MMT	2 / 50+75 / S	R210 153 000	3	50				yes	Nickel
	2.6 / 50 / S	R210 155 000							
	2.6 / 50 / S	R210 157 000							
	2.6 / 50 / D	R210 158 000							

• Upon request



PIGTAILS



Fig. 1

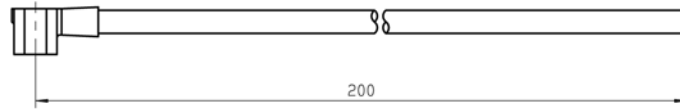
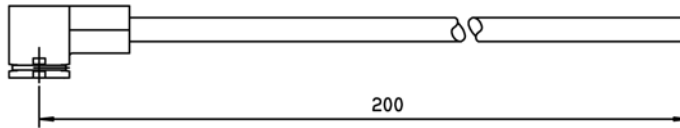

Fig. 2



Series	Cable group	Part number	Fig	Composition
MMS	1 / 50 / S	R285 001 001	1	R209 351 020 + C291 050 066
	2 / 50 / S	R285 001 021		R209 353 000 + C291 145 007
	2 / 50 / D	R285 001 031		R209 355 000+ C291 146 087
	2 / 75 / S	R285 001 041		R209 353 000 + C291 305 000
MMT	2 / 50 / S	R284 008 001	2	R210 153 000 + C291 145 007
	2 / 50 / D	R284 008 002		R210 155 000 + C291 146 087
	2.6 / 50 / S	R284 008 004		R210 157 000 + C291 170 007
	2.6 / 50 / D	R284 008 005		R210 158 000 + C291 185 067
	2 / 75 / S	R284 008 003		R210 153 000 + C291 305 000

CABLE ASSEMBLIES



Fig. 1



Fig. 2



Fig. 3

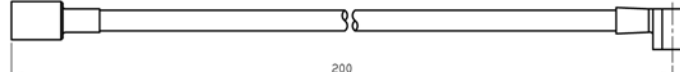

Fig. 4

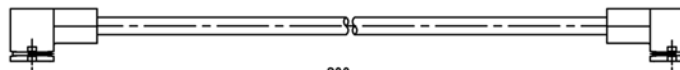
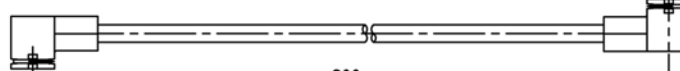
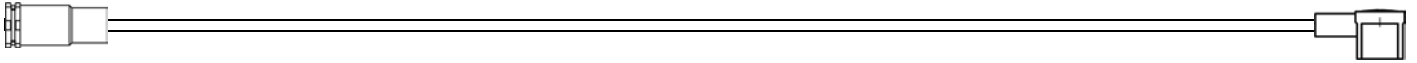

Fig. 5



Series	Cable group	Part number	Fig	Composition
MMS	1 / 50 / S	R285 004 001	1	R209 351 020 + C291 050 066 + R209 351 020
		R285 005 001	2	
	2 / 50 / S	R285 004 221	1	R209 353 000 + C291 145 007 + R209 353 000
		R285 005 221	2	R209 353 000 + C291 145 060 + R209 353 000
		R285 003 221	3	R209 080 000 + C291 145 060 + R209 353 000
MMT	2 / 50 / S	R285 011 221	4	R210 153 000 + C291 145 007 + R210 153 000
		R285 012 221	5	R210 153 000 + C291 145 060 + R210 153 000



BETWEEN SERIES CABLE ASSEMBLIES

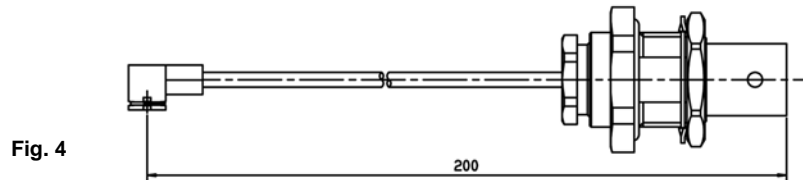
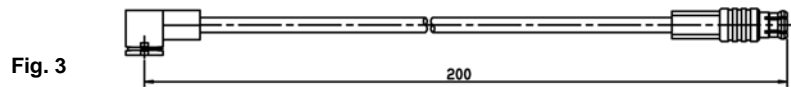
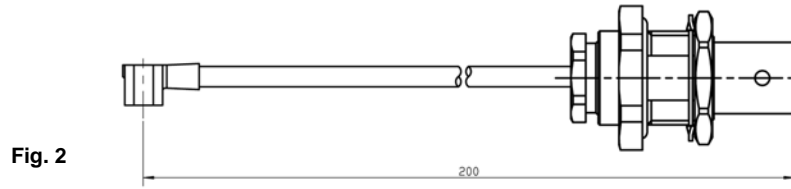
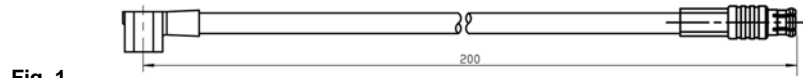

Series	Cable group	Part number	Fig	Composition	Note
MMS	2 / 50 / S	R285 017 221	1	R209 353 000 + C291 145 007 + R113 081 020	MCX
		R285 031 221	2	R209 353 000 + C291 145 007 + R141 323 000	BNC
MMT	2 / 50 / S	R285 017 331	3	R210 153 000 + C291 145 060 + R113 081 020	MCX
		R285 031 331	4	R210 153 000 + C291 145 060 + R141 323 000	BNC

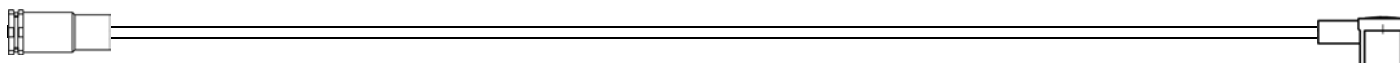

SMT RECEPTACLES

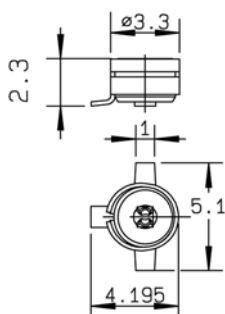

Fig. 1

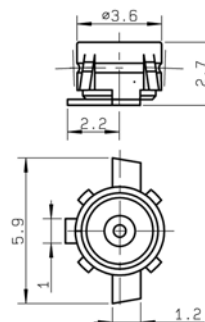

Fig. 2

Series	Part number	Fig	Imp. (Ω)	Center contact finish	Finish	Packaging	Reel dimension A
MMS	R209 408 012	1	50	Gold	Gold	reel 100 pieces	180
	R209 408 012W					unit	-
	R209 408 052					reel 500 pieces	180
	R209 408 302					reel 3000 pieces	330
MMT	R210 408 012	2	50	Gold	Gold	reel 100 pieces	180
	R210 408 052					reel 500 pieces	180
	R210 408 302					reel 3000 pieces	330

Packaging: see reel description on page 16
Soldering pattern and SMT procedure on page 18-19

TEST BOARD

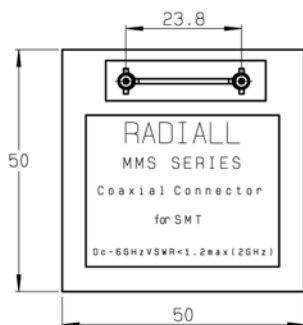
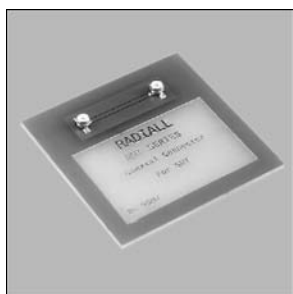

Fig. 1

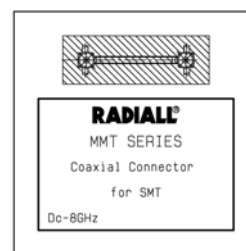
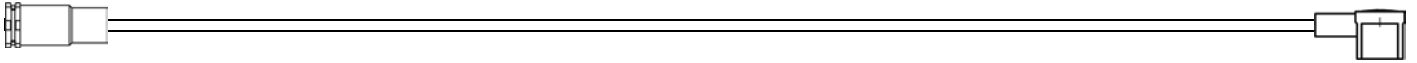

Fig. 2

Series	Part number	Fig
MMS	R209 900 500	1
MMT	R210 900 500	2

Connected to a network analyzer by 2 cable assemblies, this board allows to measure the V.S.W.R. of a complete link.



BETWEEN SERIES ADAPTERS

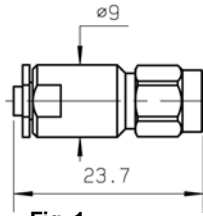

Fig. 1

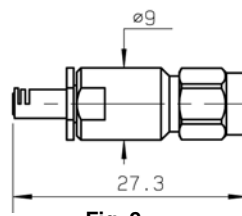

Fig. 2

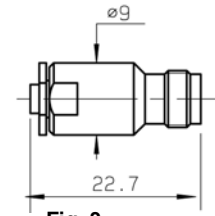

Fig. 3

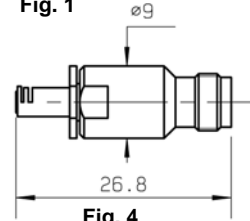

Fig. 4

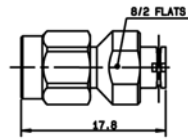

Fig. 5

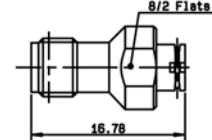

Fig. 6

Series	Part number	Fig	Type	Finish
MMS	R191 975 761	1	MMS male / SMA male	passivated stainless steel
	R191 975 771	2	MMS female / SMA male	
	R191 975 781	3	MMS male / SMA female	
	R191 975 791	4	MMS female / SMA female	
MMT	R191 392 027	5	MMT female / SMA male	BBR
	R191 394 027	6	MMT female / SMA female	

IN SERIES ADAPTERS FOR PCB TO PCB LINK

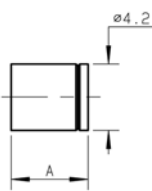

Fig. 1

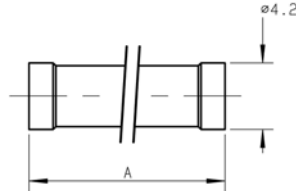

Fig. 2

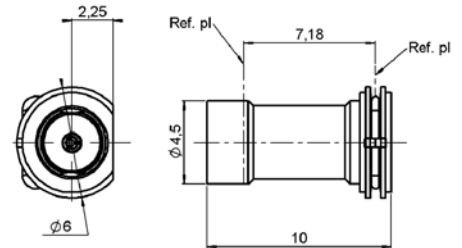
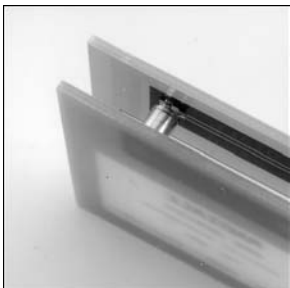

Fig. 3

Series	Part number	Fig.	Dimension A (mm)	Finish	Packaging
MMS	R209 307 000	1	4,9	Nickel	100 pcs
	R209 703 030*	2	18,5		
MMT	R210 703 507	3		BBR	100 pcs



To ease PCB linking, this adapter is designed to remain mated to one designated PCB. Therefore, the slit interface is slide-on, the other is snap-on. This adapter can also be developed upon request with other lengths, in order to adjust space between PCB (minimum distance: 6.4 mm). Please consult us.

• Upon request

MMS/MMT

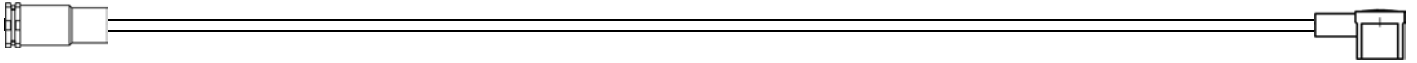

MEASUREMENT CABLE ASSEMBLIES

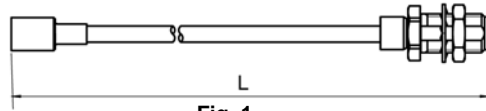

Fig. 1

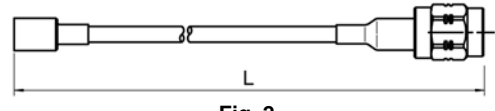

Fig. 2

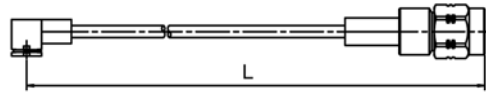

Fig. 3

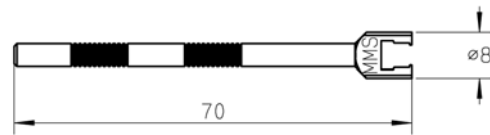
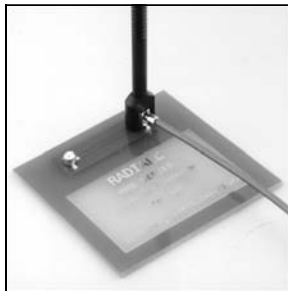

Fig. 4

Series	Cable	Part number	Fig.	Composition	Length L (mm)
MMS (1)	2 / 50 / S	R285 023 021	1	R209 080 500 + C291 145 007 + R124 310 020	200
		R284 007 013	2	R209 080 500 + C291 145 007 + R124 069 120	
MMT	2.6 / 50 / D	R285 024 071	3	R210 158 000 + C291 185 067 + R124 072 220	200
		R285 024 271	4	R210 158 000 + C291 185 067 + R124 233 120	
		R284 310 061	3	R210 158 000 + C291 185 067 + R124 072 220	60
		R284 310 062	4	R210 158 000 + C291 185 067 + R124 233 120	

(1) Both cable assemblies are equipped with a straight MMS plug with a sliding interface to allow 500 matings and a SMA connector.

EXTRACTION TOOL



Series	Part number
MMS	R282 868 100
MMT	R282 868 030

Materials and finish : black anodized aluminium

The anodization allows the electric insulation and protects from the oxidization.

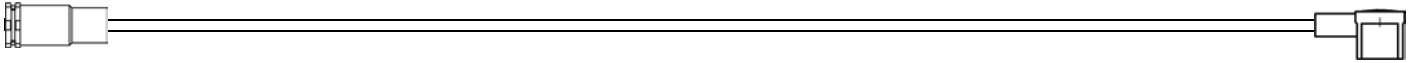

ACCORDING TO IEC 286-3 STANDARD

MATERIALS

Reel : polyester

Carrier tape : antistatic PETG (polyester)

Cover tape : polyester

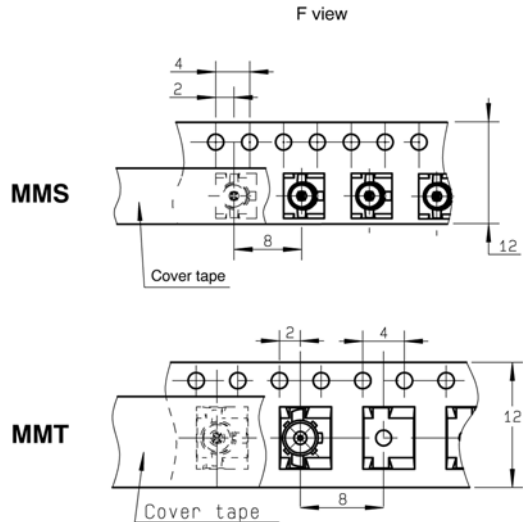
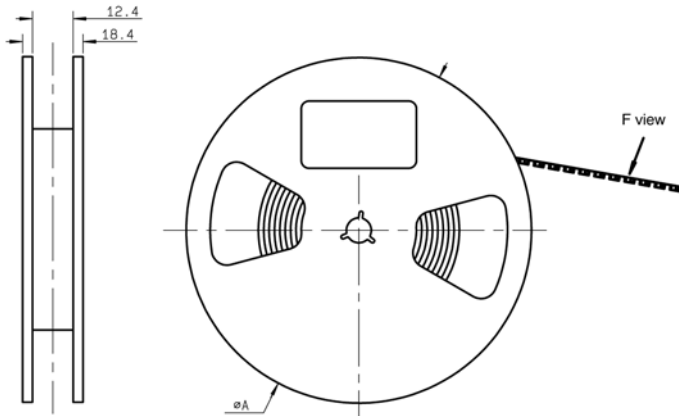

Packaging	Dia. A
100 & 500	180
3000	330

PRECAUTION FOR USE

Automated pick and place machines use standard tooling to peel the antistatic film off. Sometimes the "a" dimension of this tool is shorter than the overall "b" width between the two legs of the receptacle. There is thus a risk for the two legs being deformed while they pass through the tool during the suction operation. The user must then widen the "a" dimension of the peeling tool.

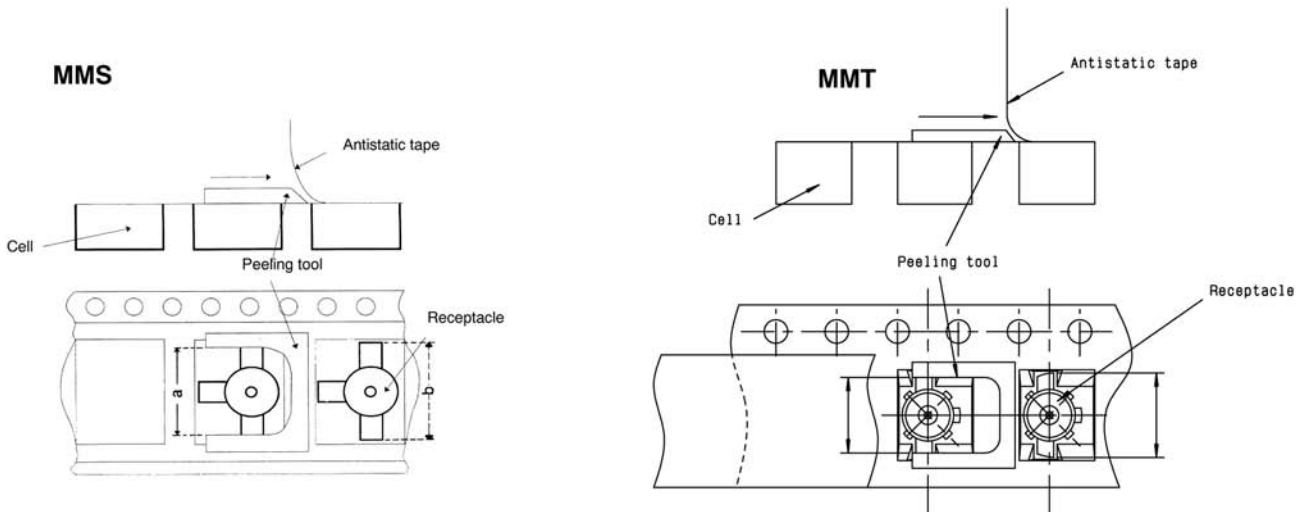

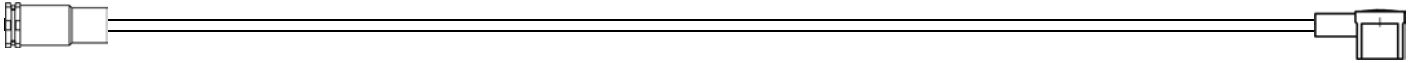

PIGTAILS (or cable assemblies)

The right angle plugs are delivered as pigtails or cable assemblies.

(Over 100.000 pieces, other assembling possibilities can be custom tailored upon request)

How to order

Examples of composition (minimum length = 1.575 (4 cm) ± 2 %):

Example 1:

Pigtail featuring one right angle plug.

Connector / Cable / Length (cm)

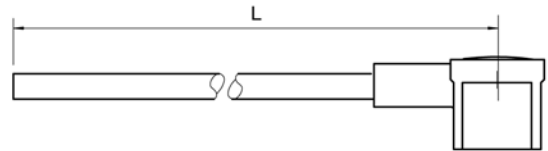

Example 2:

Pigtail featuring one right angle plug with stripping option (stripping according to customers requirements with possibility of tin central conductor).

Connector / Cable / Length (cm) A= (mm) B= (mm) C= (mm)

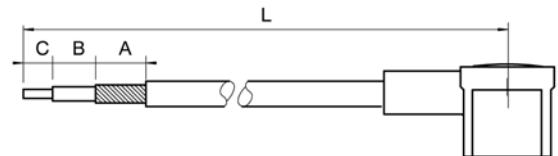

Example 3:

Cable assembly featuring two right angle plugs

Connector / Cable / Connector / Length (cm)

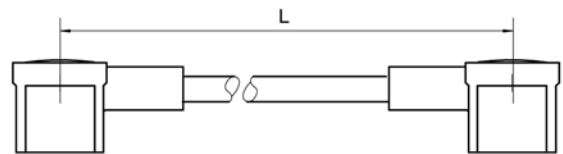

Example 4:

Cable assembly featuring one MMS or MMT right angle plug and any other connector compatible with cable.

Connector / Cable / R... .. (*) / Length (cm)

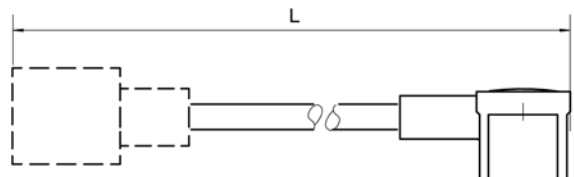

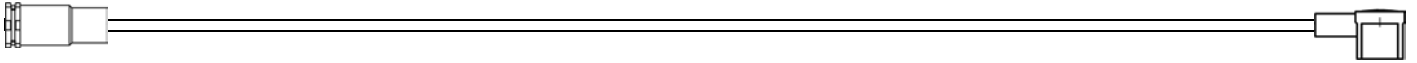

VIDEO SHADOW AND SOLDERING PATTERN OF THE RECEPTACLE

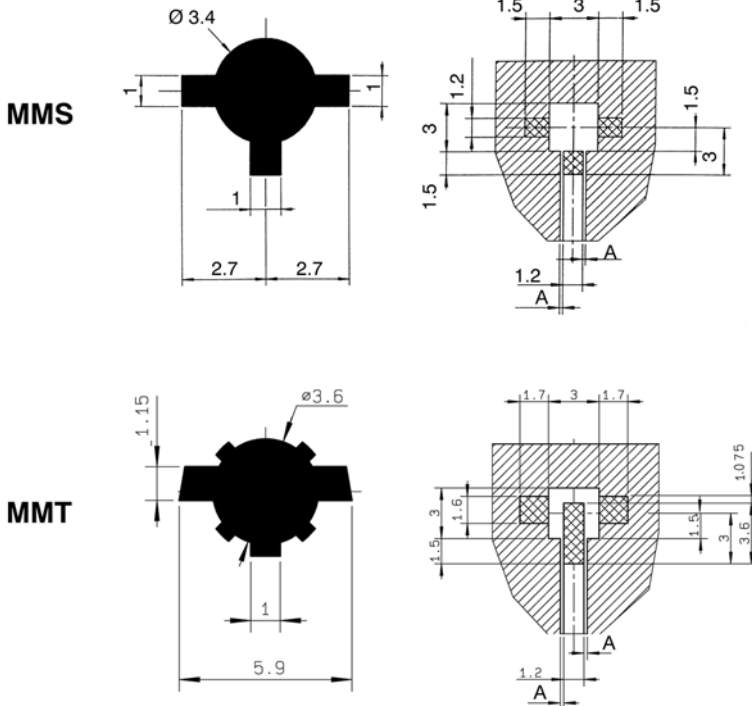

Coplanar circuit on PCB
 PCB material : glass epoxy composite (e r = 4.6)
 Ground and signal are on the same side.

PCB thickness (mm)	Coplanar line A (mm)
0.8	0.183
1.0	0.190
1.2	0.195
1.6	0.2

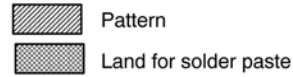

SUCTION PROCEDURE FOR RECEPTACLE

MMS

MMT

\varnothing OF NOZZLE > 1.2 mm \varnothing OF NOZZLE < 1.2 mm
 Suction with the central contact hole. Suction with insulator.

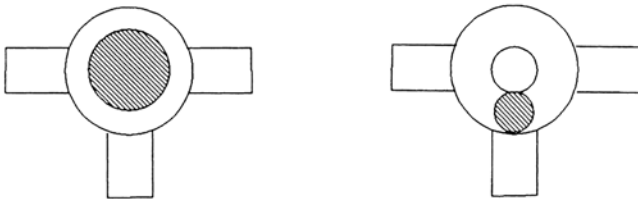

ASPIRATION AREA

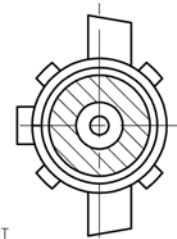

EXAMPLES OF PNEUMATIC NOZZLES

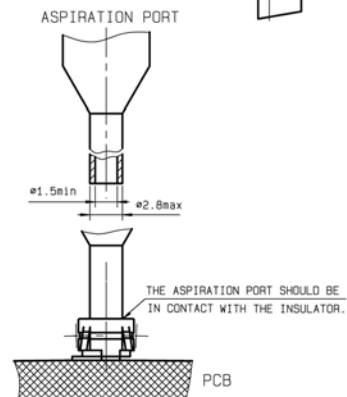
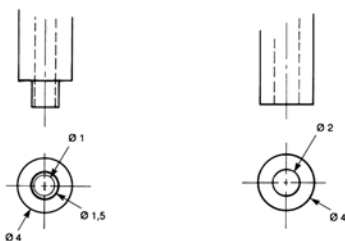

SOLDER PROCEDURE

1

Deposit solder paste 'Sn Ag4 Cu0.5' on mounting zone by screen printing application. We recommend a low residue flux. We advise a thickness of 150 micromm (5.850 microinch). Verify that the edges of the zone are clean.

2

Placement of the receptacle on the mounting zone with an automatic machine of 'pick and place' type. Video camera is preferred to check the positioning of the component. Adhesive agents are forbidden on the receptacle.

3

Soldering by infra-red reflow.

4

Cleaning of printed circuit boards.

5

Cheeking of solder joints and position of the component by visual inspection.

TEMPERATURE PROFILE

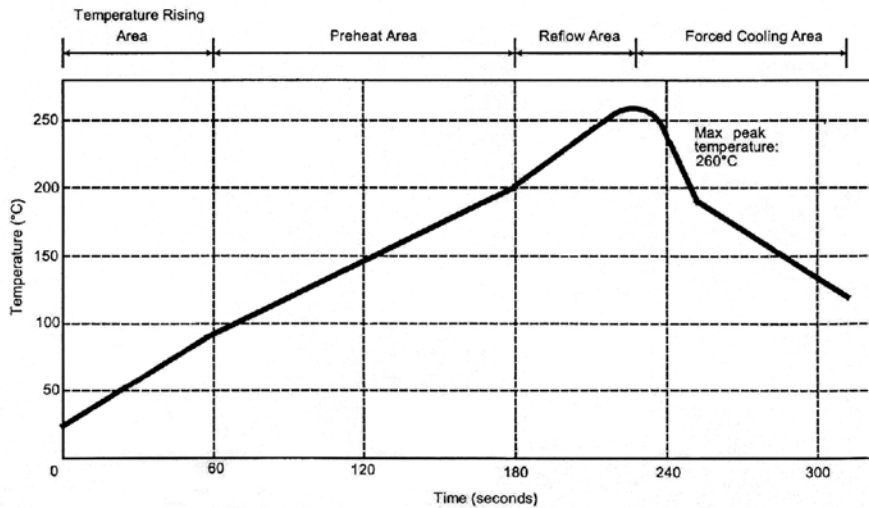

Parameter	Value	Unit
Temperature rising Area	1 - 4	°C/sec
Max Peak Temperature	260	°C
Max dwell time @260°C	10	sec
Min dwell time @235°C	20	sec
Max dwell time @235°C	60	sec
Temperature drop in cooling Area	-1 to -4	°C/sec
Max dwell time above 100°C	420	sec



50 Ω

DC - 6 GHz

GENERAL

- Subminiature coaxial connectors
- Push-pull" snap-on mating
- Complies with specification CECC 22000

APPLICATIONS

- Wireless LANs
- PCMCIA cards
- RF test ports
- Base stations

MMCX series from Radiall combine intermatability with CECC 22000 compliant supplier and high manufacturing quality.

MMCX series is especially dedicated to wire to PCB connection where low space above the PCB is available (less than 2.1 mm)

Due to Radiall manufacturing quality standard, our MMCX provide positive tactile feedback.

MMCX is adapted to high volume applications and Pick & Place manufacturing process.

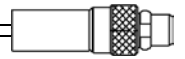

PLUG

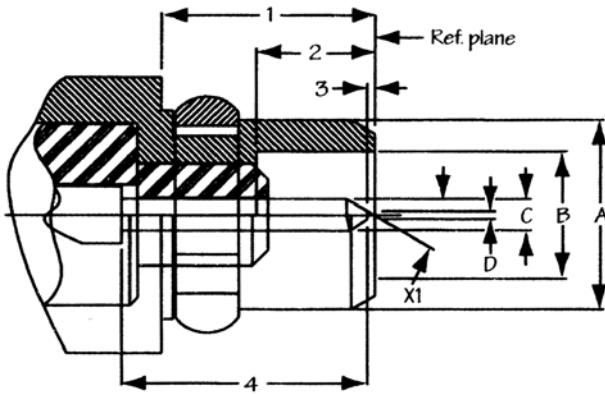

JACK

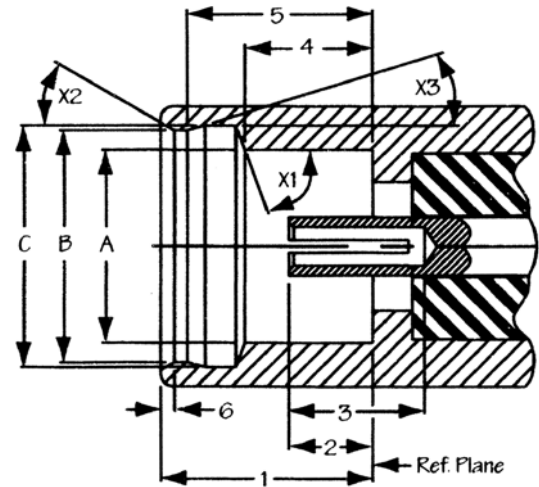

	mm		inch	
	min.	max.	min.	max.
1	2.70		.106	
2	1.45		.057	
3	0	0.25		.010
4		3.15		.124
A	2.40		.095	
B	1.58	1.62	.062	.064
C	0.38	0.42	.015	.017
D		0.20		.008
X1	29°	31°		

	mm		inch	
	min.	max.	min.	max.
1	2.60		.102	
2	0.90	1.20	.035	.047
3	1.40		.055	
4	1.57	1.63	.062	.064
5	2.30	2.34	.091	.092
6		0.23		.009
A	2.41		.095	
B	2.88	2.90	.113	.114
C	3.00	3.04	.118	.120
X1	68°	72°		
X2	28°	32°		
X3	13°	17°		



	TEST STANDARD	VALUES/REMARKS
--	---------------	----------------

ELECTRICAL CHARACTERISTICS

Impedance		50 Ω
Frequency range		DC–6 GHz
V.S.W.R.	CECC 22000 4.4.1	Edge card SMT: 1.40 max Cabled: 1.35 max
Dielectric withstanding voltage (at sea level)	CECC 22000 4.4.5	500 V RMS 50 Hz
Insulation resistance	CECC 22000 4.4.4	1000 M Ω min

MECHANICAL CHARACTERISTICS

Engagement force	CECC 22000 4.5.4	3.5 lbs max
Disengagement force	CECC 22000 4.5.4	1.4 lbs to 3.4 lbs max
Contact captivation	CECC 22000 4.5.2	2.3 lbs min
Durability (mating)	CECC 22000 4.7.1	500 cycles min

ENVIRONMENTAL CHARACTERISTICS

Temperature range		–55°C / +155°C
Temperature shock	CECC 22000 4.6.7	in conformance
Vibration	CECC 22000 4.6.3	in conformance

MATERIALS

Bodies	Brass
Center contact male female	Brass Beryllium copper
Insulator	PTFE

PLATINGS

Bodies	Gold
Center contact male and female	Gold

These characteristics are typical and may not apply to all connectors.

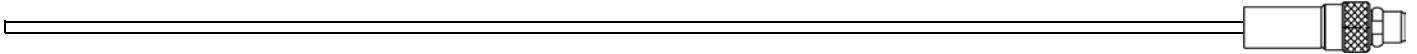

STRAIGHT PLUGS FULL CRIMP TYPE FOR FLEXIBLE CABLE

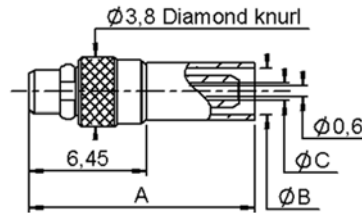

Cable group	Part number	Dimensions (mm)			Assembly instructions	Packaging
		A	B	D		
2 / 50 / S	R110 081 020	0.97	2.55	12.45	M01	100
2.6 / 50 / S	R110 083 120	1.61	2.95	13.35		

RIGHT ANGLE PLUGS

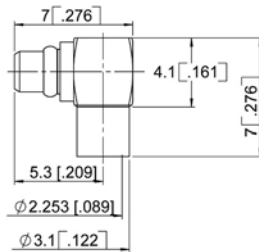
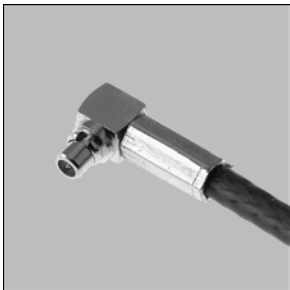

Fig. 1

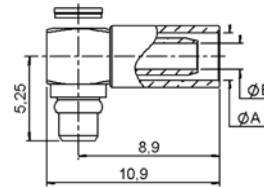
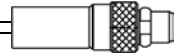

Fig. 2

Cable group	Part number	Fig	Dimensions (mm)		Assembly instructions	Packaging
			A	B		
.085"	R110 153 000	1			M03	100
2 / 50 / S	R110 170 100	2	0.97	2.55	M02	
2.6 / 50 / S	R110 172 100	2	1.61	2.95		



PCB EDGE CARD RECEPTACLES

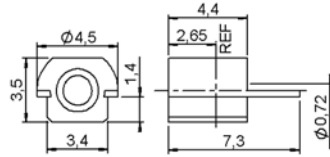

Fig. 1

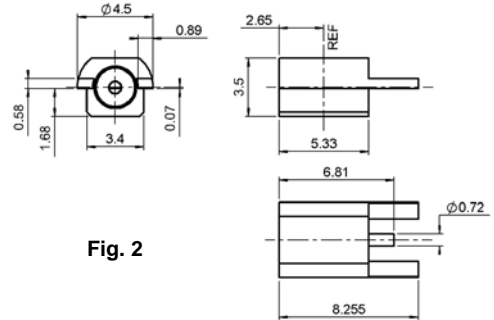

Fig. 2

Part number	Fig	Gender	Packaging	Notes
R110 422 100W	1	jack	1	SMT
R110 422 100	1		100	
R110 422 830	1		reel of 1500 pcs	
R110 422 200W	2	jack	1	SMT/offset
R110 422 200	2		100	
R110 422 800	2		reel of 1500	

STRAIGHT PCB RECEPTACLES

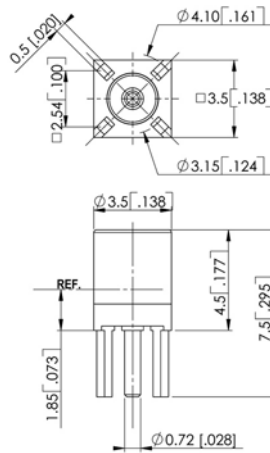
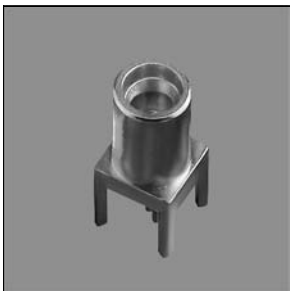

Fig. 1

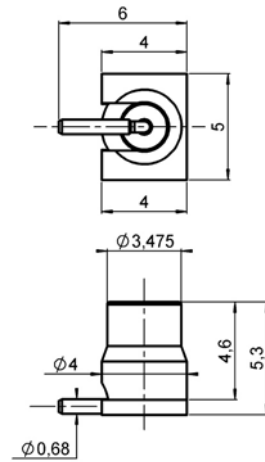

Fig. 2

Part number	Fig	Gender	Panel drilling	Packaging	Notes
R110 426 000	1	jack	P01	100	Tru-hole
R110 427 820	2			reel of 500 pcs	SMT

ACCORDING TO IEC 286-3 STANDARD

MATERIALS

Reel : polyester

Carrier tape : antistatic PETG (polyester)

Cover tape : polyester

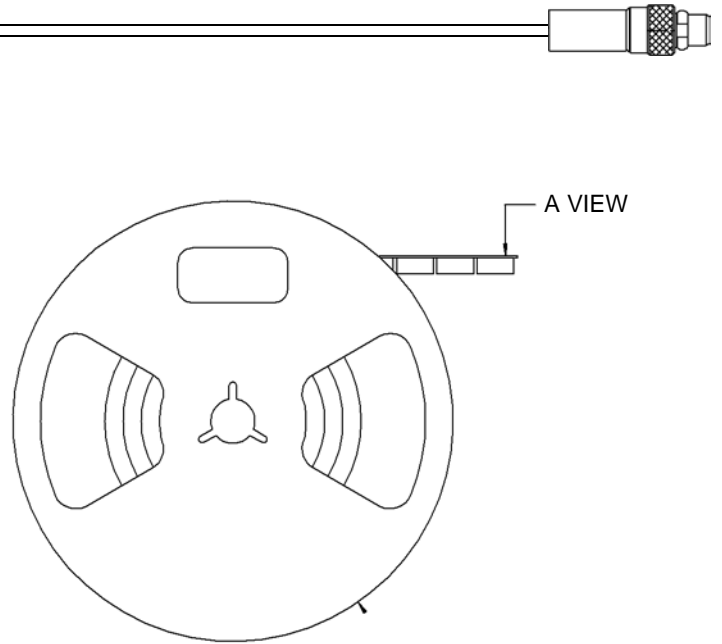

PRECAUTION FOR USE

Automated pick and place machines use standard tooling to peel the antistatic film off. Sometimes the "a" dimension of this tool is shorter than the overall "b" width between the two legs of the receptacle. There is thus a risk for the two legs being deformed while they pass through the tool during the suction operation. The user must then widen the "a" dimension of the peeling tool.

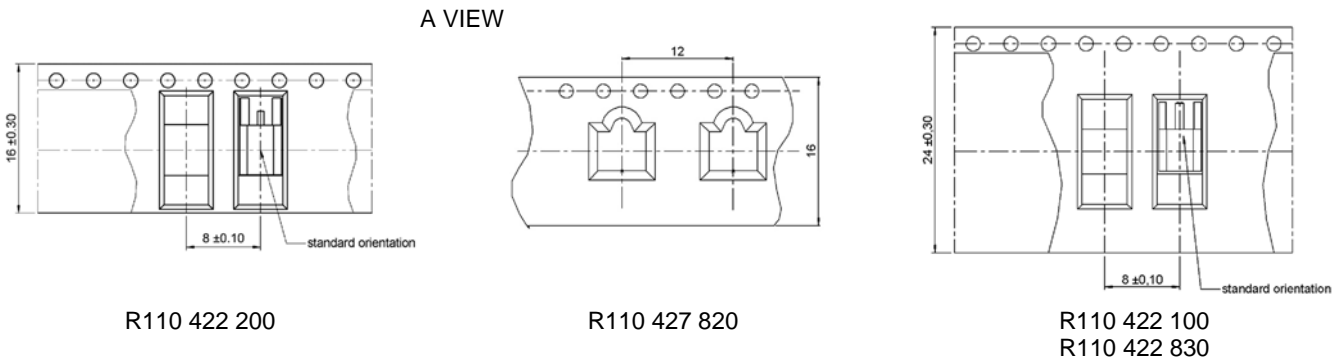

PANEL DRILLING

P01

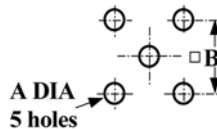

	mm		inch	
	max.	min.	max.	min.
A	0.85	0.75	.033	.030
B	2.56	2.52	.101	.099

M 01

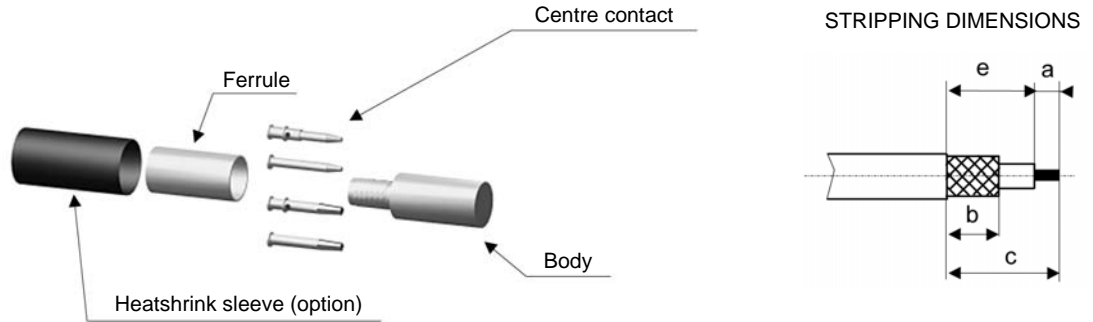

Part number	Stripping length (mm)				Crimp tools		Center contact crimp tool R282 281 000 (M22520/2-01) + positioner
	a	b	c	e	dies included	MIL standard R282 293 000 (M22520/5-01) + dies	
R110 081 020	1.60	5.30	8.80	7.20	R282 211 000 hex 2.67	R282 235 003 (M22520/5-03) hex 2.67	R282 967 070 2*4 pos 1
R110 083 120					R282 271 000 hex 3.25	R282 235 003 (M22520/5-03) hex 3.25	R282 967 070 2*4 pos 3

- 1**
- Slide the heatshrink sleeve onto the cable (option).
 - Slide the ferrule onto the cable.
 - Strip the cable.

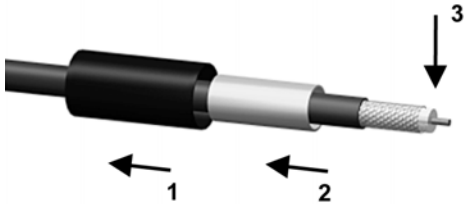

- 2**
- Slide the centre contact on until it bottoms against the cable dielectric.
 - Crimp the centre contact with crimping tool (see table).

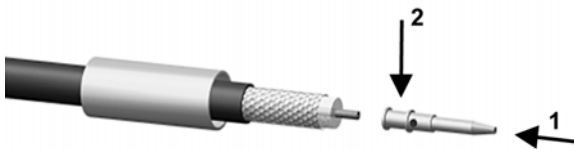

- 3**
- Fan the braid.

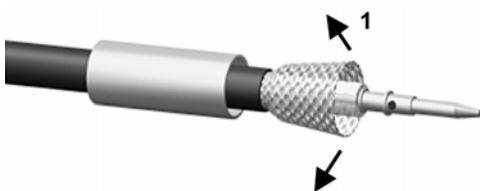

- 4**
- Slide the cable into the body until it bottoms against insulator.

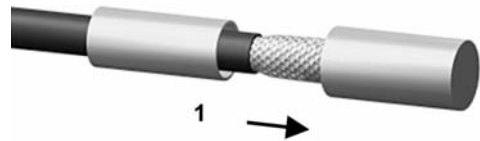

- 5**
- Slide the ferrule over the braid.
 - Crimp the ferrule with crimping tool (see table).

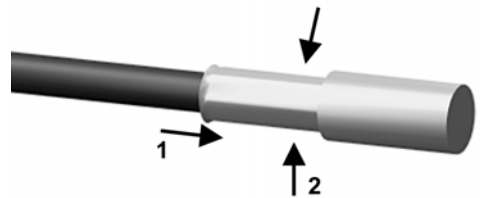

- 6**
- Cut the excess of braid if necessary.
 - Slide the sleeve over the ferrule and heatshrink it in place (option).

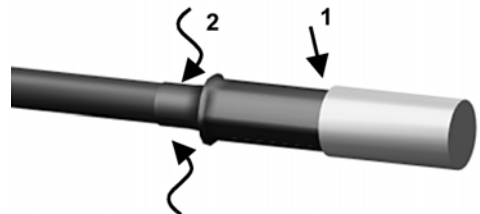

M 02

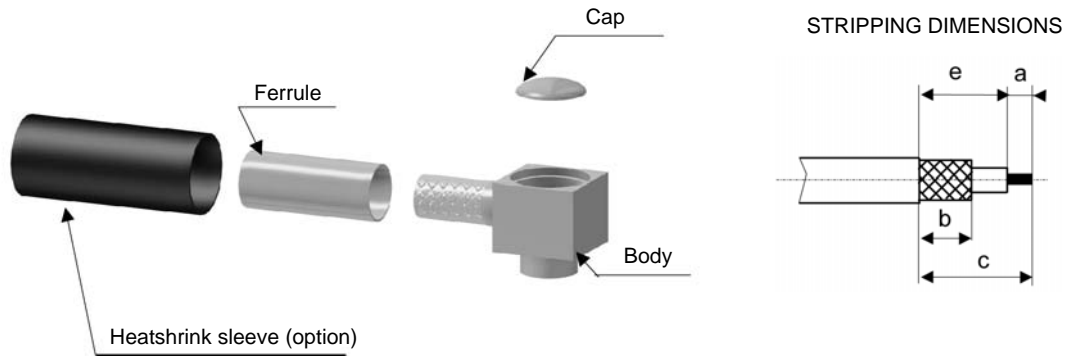

Part number	Stripping length (mm)				dies included	Crimp tools
	a	b	c	e		
R110 170 100	1.40	6.35	9.00	7.60	R282 235 003 Hex 3.25	MIL standard R282 293 000 (M22520/5-01) + dies
R110 172 100						R282 271 000 Hex 3.25

- 1**
- Slide the heatshrink sleeve onto the cable (Option).
 - Slide the ferrule onto the cable.
 - Strip the cable.

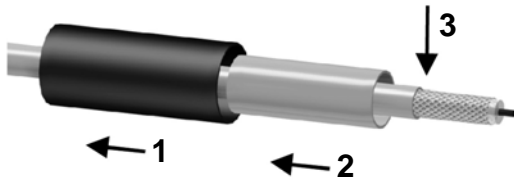

- 2**
- Fan the braid.



- 3**
- Push the connector body under the braid.
 - Slide the ferrule over the braid.



- 4**
- Crimp the ferrule with crimping tool (see table).
 - Solder the inner conductor.

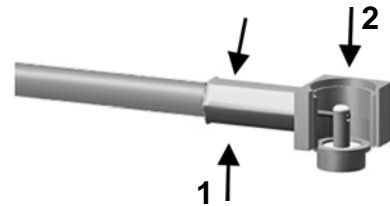

- 5**
- Place the cap into the body.

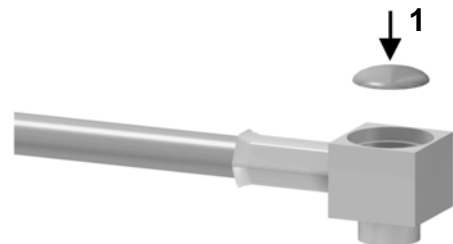

- 6**
- Press on the cap flush or slightly below the surface of the body assembly.
 - Slide the sleeve over the ferrule and heatshrink it in place (Option).

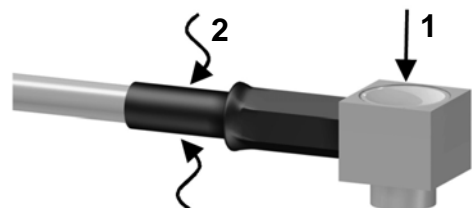

M 03

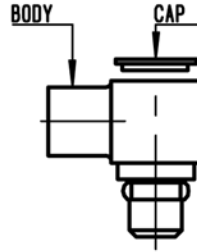

STRIPPING DIMENSIONS

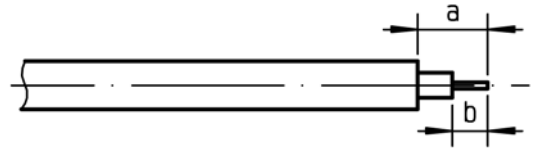

We recommend a thermal preconditioning cable

Part Number	Stripping length (mm)		Assembly jig
	A	B	
R110 153 000	2.6	2	R282 740 020

- 1**
- Strip the cable.
 - Clean the cable.
 - Tin cable inner conductor.

- 2**
- Introduce the cable into the connector body until contact with the body shoulder, place the sub assembly into the assembly jig R282 740 020 and tighten it.
 - Solder body on the cable and let assembly cool down before removing it from the jig.
 - Clean soldering area.

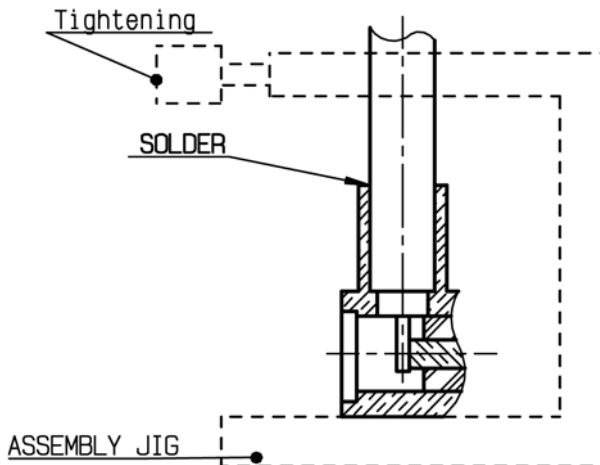

- 3**
- Solder cable inner conductor into the centre contact.
 - Clean soldering area.

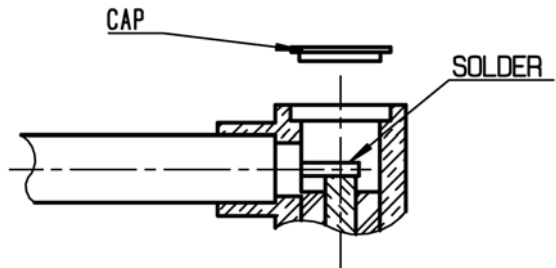

- 4**
- Put the cap in its place.
 - Press cap flush or slightly below surface or body assembly.

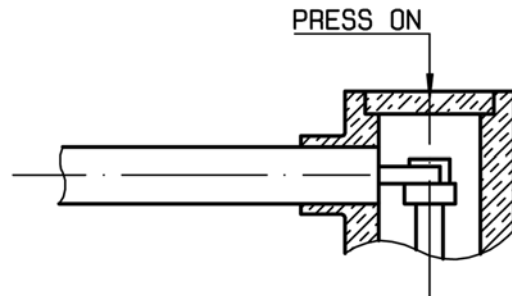

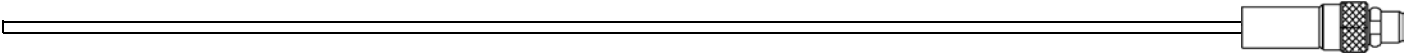

R110 427 820

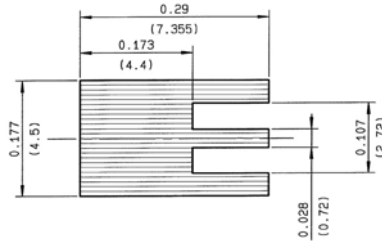
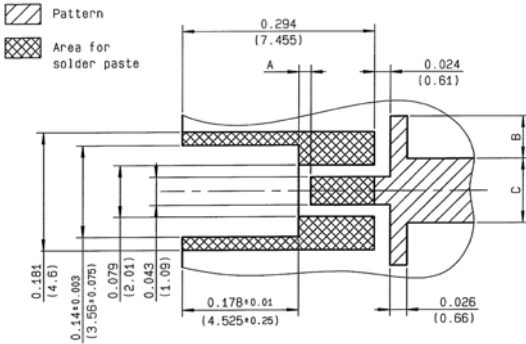
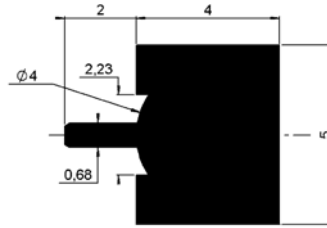
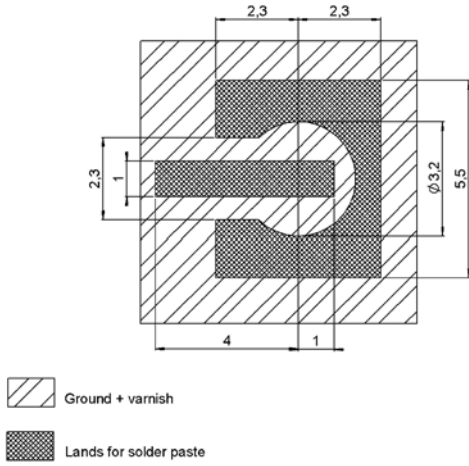

PCB THICKNESS	A	B	C
0.031 (0.79)	0.039 (0.99)	-	0.055 (1.4)
0.039 (0.99)	0.035 (0.89)	0.012 (0.3)	0.071 (1.8)
0.063 (1.6)	0.016 (0.41)	0.063 (1.6)	0.11 (2.79)

R110 422 100
R110 422 830

R110 422 200
R110 422 800

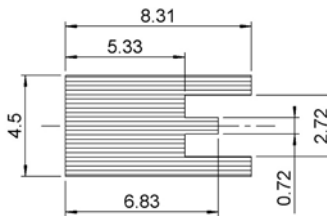
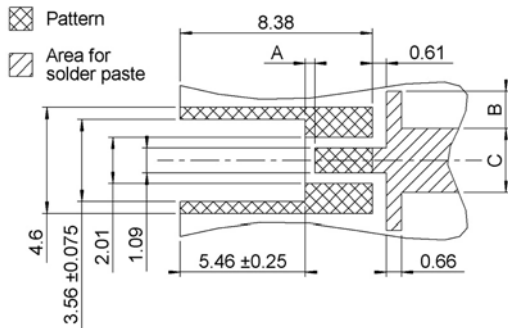

PCB THICKNESS	A	B	C
0.79	0.99	-	1.4
0.99	0.89	0.3	1.8
1.6	0.41	1.6	2.79

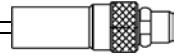

SOLDER PROCEDURE

1

Deposit solder paste 'Sn Ag4 Cu0.5' on mounting zone by screen printing application. We recommend a low residue flux. We advise a thickness of 150 micromm (5.850 microinch). Verify that the edges of the zone are clean.

2

Placement of the receptacle on the mounting zone with an automatic machine of 'pick and place' type. Video camera is preferred to check the positioning of the component. Adhesive agents are forbidden on the receptacle.

3

Soldering by infra-red reflow.

4

Cleaning of printed circuit boards.

5

Cheeking of solder joints and position of the component by visual inspection.

TEMPERATURE PROFILE

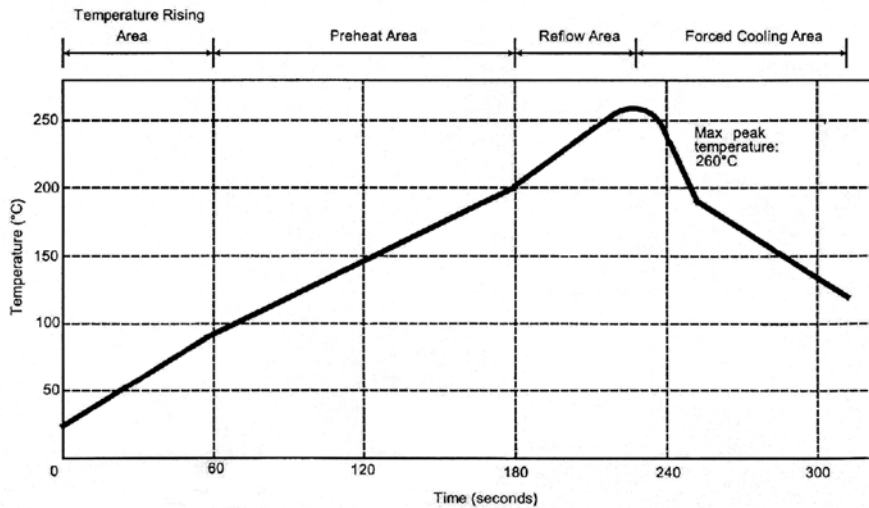

Parameter	Value	Unit
Temperature rising Area	1 - 4	°C/sec
Max Peak Temperature	260	°C
Max dwell time @260°C	10	sec
Min dwell time @235°C	20	sec
Max dwell time @235°C	60	sec
Temperature drop in cooling Area	-1 to -4	°C/sec
Max dwell time above 100°C	420	sec