

Jul.1.2024 Copyright 2024 HIROSE ELECTRIC CO., LTD. All Rights Reserved.
In case of consideration for using Automotive equipment / device which demand high reliability, kindly contact our sales window correspondents.

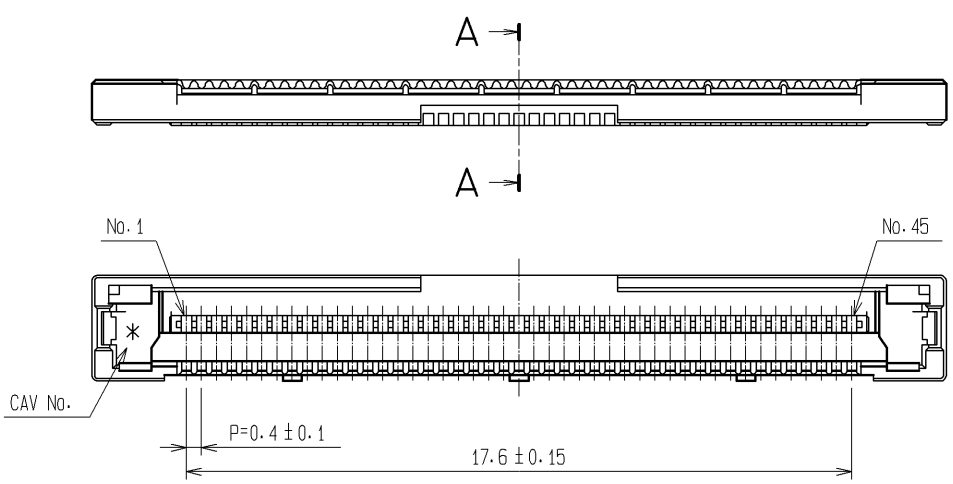

RECOMMENDED CABLE SUBASSEMBLY

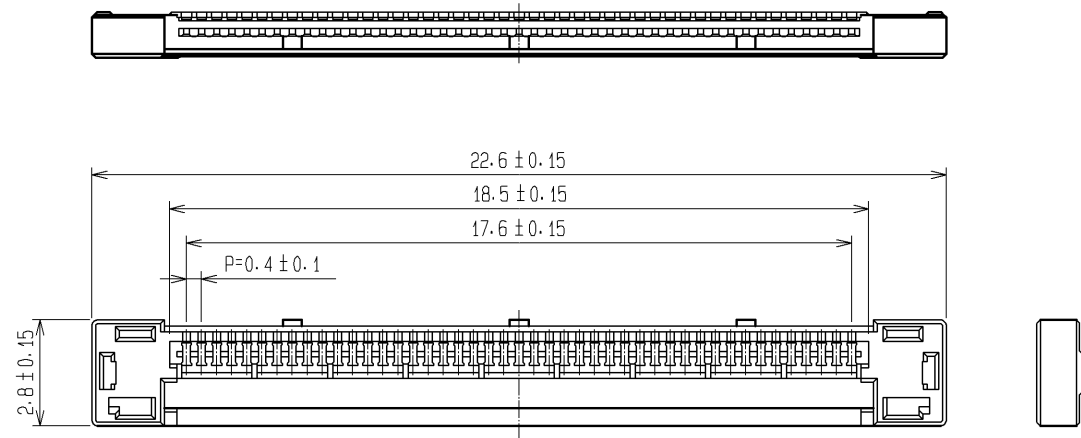
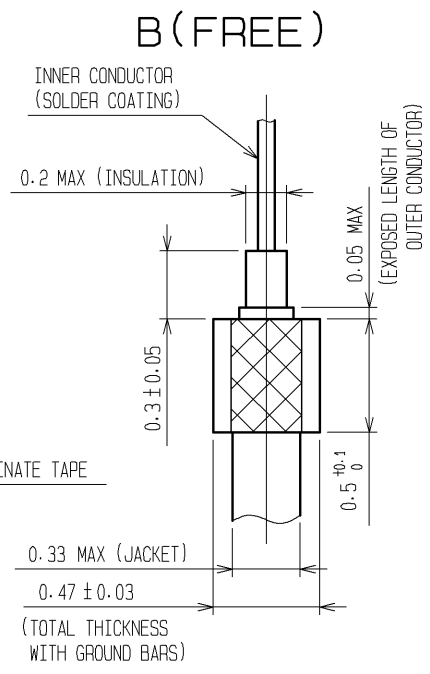
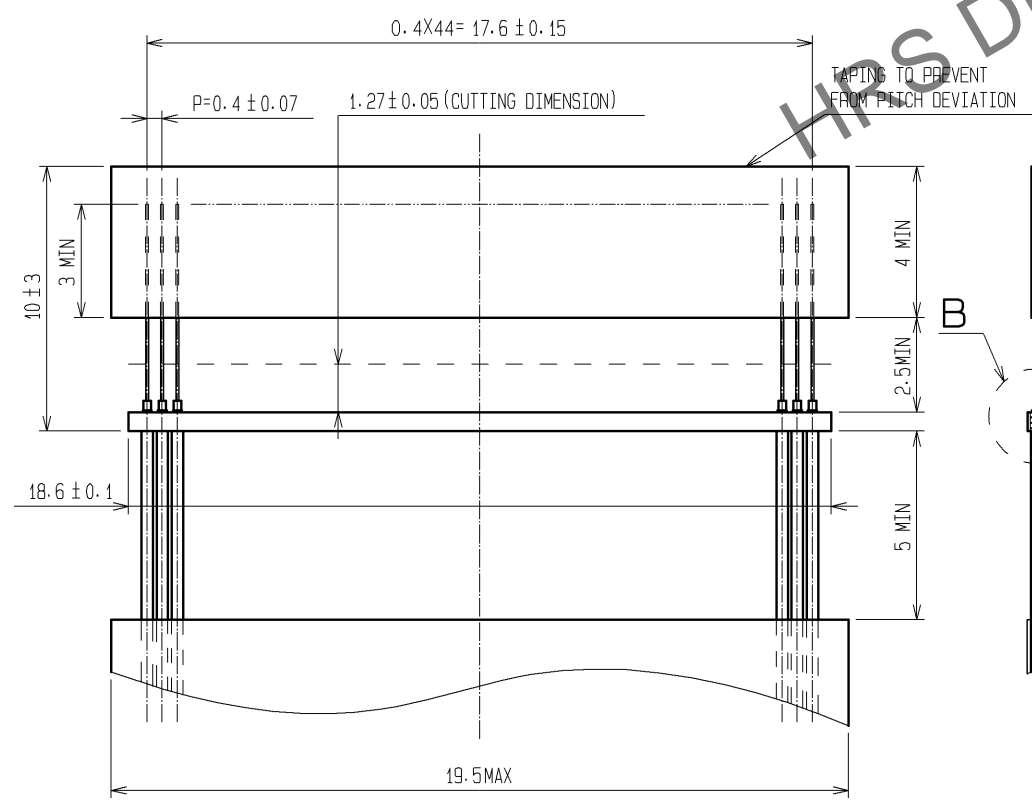

A-A (FREE)

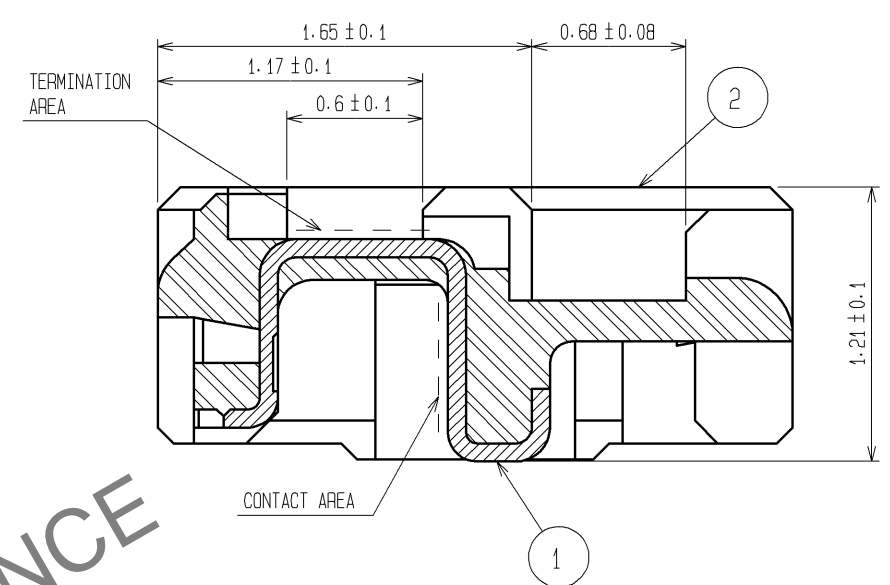

CABLE TERMINATION FIGURE (FREE)

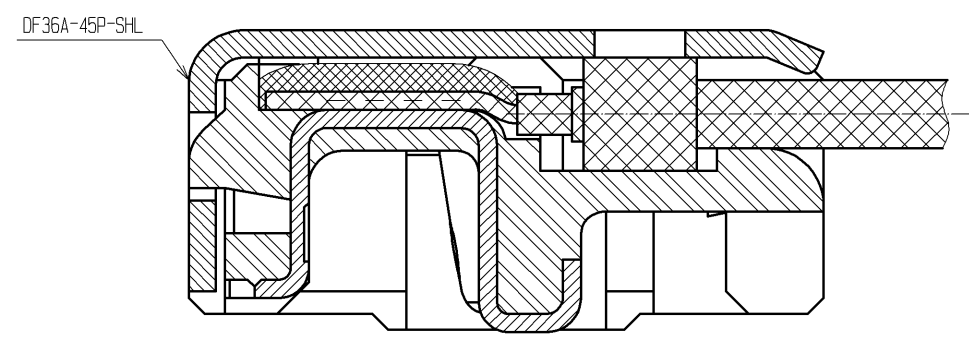

- NOTES 1. APPLICABLE CABLE: THIN COAXIAL CABLE (AWG#42~AWG#46)
 2. THIS CONNECTOR IS NOT HOT PLUGGABLE. MATE AND UNMATE WHILE THE POWER IS OFF.
 3. THE ASSEMBLY IS COMPLETED BY COMBINING TWO PARTS (CONNECTOR UNIT, AND METAL SHIELDING). REFER TO THE TABLE FOR EACH ITEM No., PART NAME, PART No AND CODE No.

ITEM No.	PART NAME	PART No.	CODE No.
1.2	CONNECTOR UNIT	DF36-45P-0.4SD(51)	CL662-4009-2-51
-	METAL SHIELDING	DF36A-45P-SHL	CL662-4010-1-00

4. BLACK MARKS MAY OCCASIONALLY OCCUR IN MOLD RESIN, YET THEY DO NOT AFFECT CONNECTOR QUALITY.

NO.	MATERIAL	FINISH	REMARKS	NO.	MATERIAL	FINISH	REMARKS
1	PHOSPHOR BRONZE	CONTACT AREA : Au PLATING 0.1µm min TERMINATION AREA : Au PLATING 0.1µm min UNDER PLATING : Ni PLATING 1µm min		5	PS	BLACK	
				4	POLYESTER	CLEAR	
				3	PS	CLEAR	
				2	LCP	UL94V-0	

UNITS	SCALE	COUNT	DESCRIPTION OF REVISIONS	DESIGNED	CHECKED	DATE
mm	5 : 1	2	DIS-D-002964	IO. DENPOUYA	TS. SAKATA	13.07.04

APPROVED	DATE	DRAWING NO.
TS. SAKATA	08.07.25	EDC3-313246-02
CHECED	DATE	PART NO.
HK. UMEHARA	08.07.25	DF36-45P-0.4SD(51)
DESIGNED	DATE	CODE NO.
HY. SHIOZAWA	08.07.24	CL662-4009-2-51
DRAWN	DATE	
SI. ISHII	08.07.18	

Jul.1.2024 Copyright 2024 HIROSE ELECTRIC CO., LTD. All Rights Reserved.
 In case of consideration for using Automotive equipment / device which demand high reliability, kindly contact our sales window correspondents.

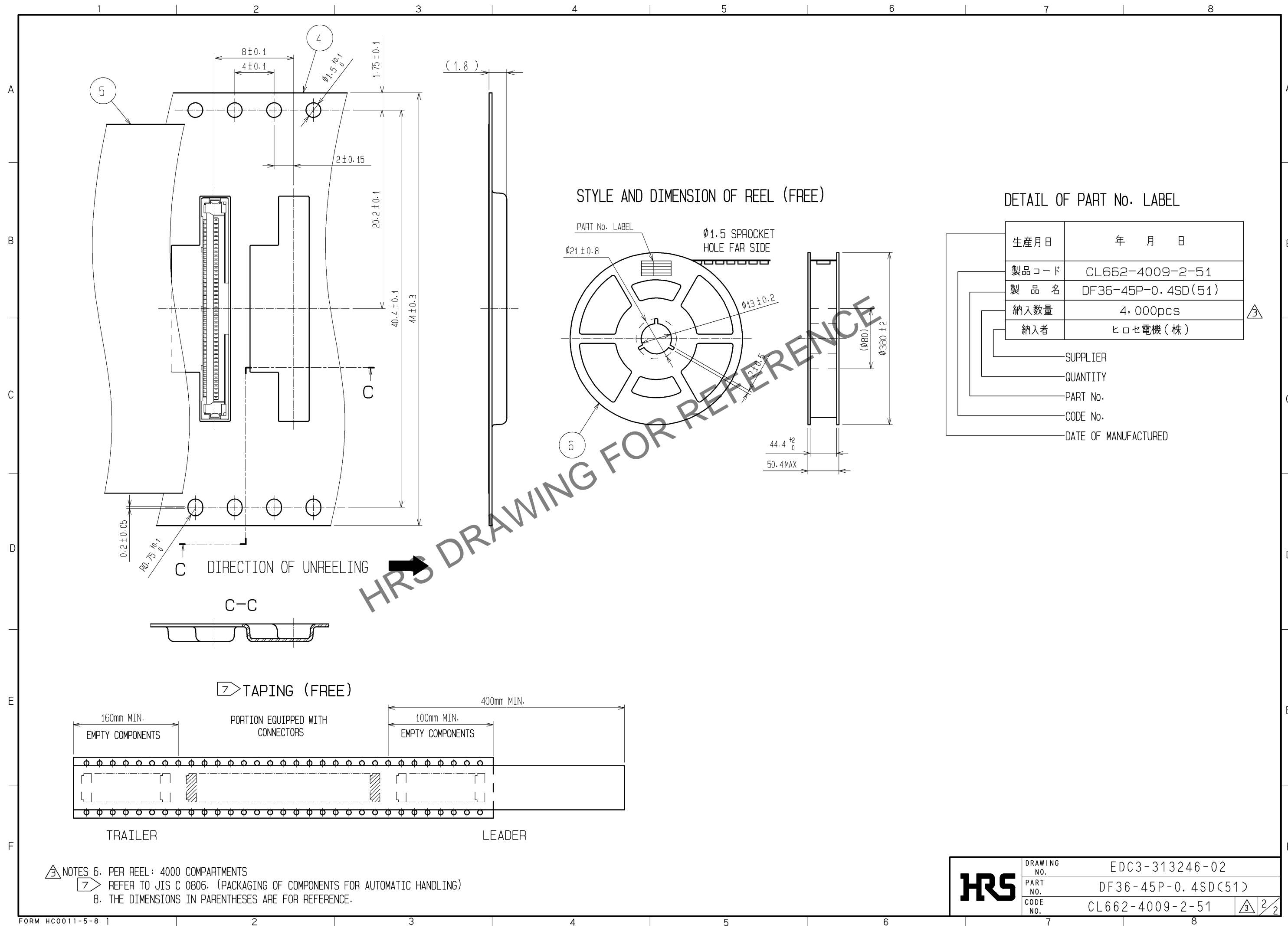

DETAIL OF PART No. LABEL

生産月日	年 月 日
製品コード	CL662-4009-2-51
製品名	DF36-45P-0.4SD(51)
納入数量	4,000pcs
納入者	ヒロセ電機(株)

SUPPLIER
 QUANTITY
 PART No.
 CODE No.
 DATE OF MANUFACTURED

- ③ NOTES 6. PER REEL: 4000 COMPARTMENTS
 ⑦ REFER TO JIS C 0806. (PACKAGING OF COMPONENTS FOR AUTOMATIC HANDLING)
 8. THE DIMENSIONS IN PARENTHESES ARE FOR REFERENCE.

HRS	DRAWING NO.	EDC3-313246-02
	PART NO.	DF36-45P-0.4SD(51)
	CODE NO.	CL662-4009-2-51
		③ 2/2