

DESIGNED & DIMENSIONED
IN MILLIMETERS

DO NOT
SCALE FROM
THIS PRINT

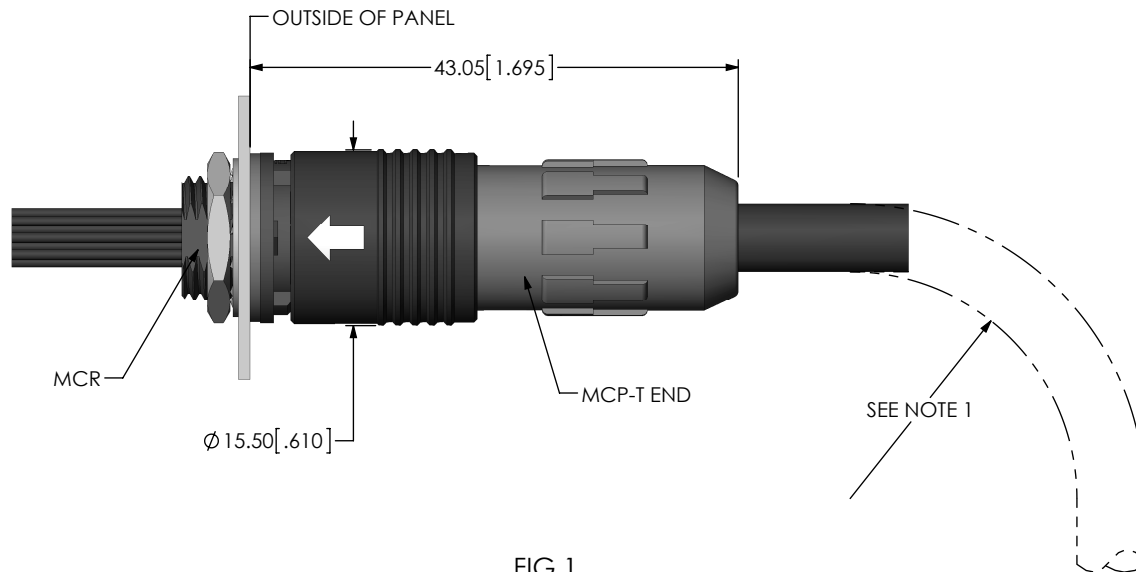

FIG 1
PANEL MATED VIEW

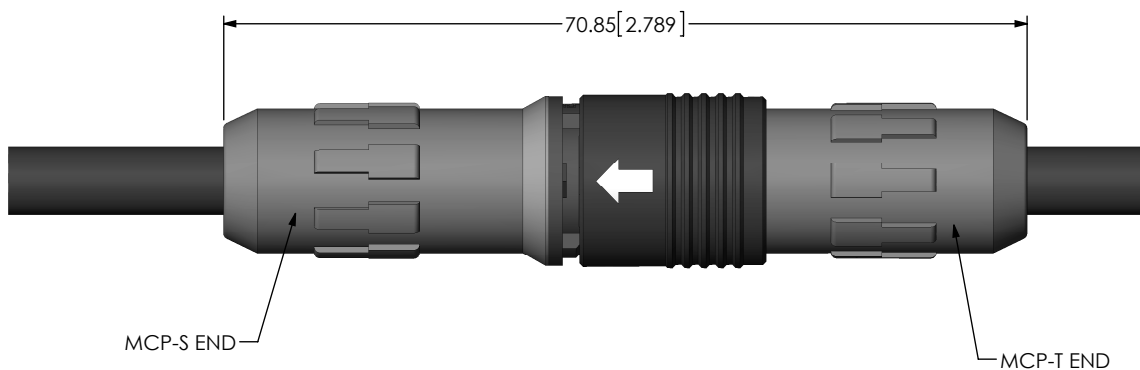

FIG 2
INLINE MATED VIEW

NOTES:

1. MINIMUM BEND RADIUS: R100.0 [3.94] (TYP).

PROPRIETARY NOTE

THIS DOCUMENT CONTAINS INFORMATION
CONFIDENTIAL AND PROPRIETARY TO
SAMTEC, INC. AND SHALL NOT BE REPRODUCED
OR TRANSFERRED TO OTHER DOCUMENTS OR
DISCLOSED TO OTHERS OR USED FOR ANY
PURPOSE OTHER THAN THAT WHICH IT WAS
OBTAINED WITHOUT THE EXPRESSED WRITTEN
CONSENT OF SAMTEC, INC.



520 PARK EAST BLVD., NEW ALBANY, IN 47150
PHONE: 812-944-6733 FAX: 812-948-5047
e-Mail info@SAMTEC.com code 55322