

TMC 7 B1 TERM - Terminal adapter



1022233

<https://www.phoenixcontact.com/us/products/1022233>

Please be informed that the data shown in this PDF document is generated from our online catalog. Please find the complete data in the user documentation. Our general terms of use for downloads are valid.



Feeder terminal adapter for TMC 71 circuit breakers, single-phase bus bars. Rated for 1000 V AC/DC, 115 A. Wire range 10...1/0 AWG. UL 508 Listed for connection to UL 1077 rated circuit breakers.

Product description

Feed-in terminal adapter for TMC 7 single-pos. bus bars

Commercial data

Item number	1022233
Packing unit	1 pc
Minimum order quantity	1 pc
Note	Made to order (non-returnable)
Sales key	CL09
Product key	CLA126
GTIN	4055626516004
Weight per piece (including packing)	26.34 g
Weight per piece (excluding packing)	26.34 g
Customs tariff number	85369010
Country of origin	DE

TMC 7 B1 TERM - Terminal adapter



1022233

<https://www.phoenixcontact.com/us/products/1022233>

Technical data

Product properties

Type	Adapter
------	---------

Electrical properties

Number of phases	1
Rated voltage (III/3)	1000 V AC/DC

Connection data

Tightening torque, min	5.65 Nm
------------------------	---------

Dimensions

Dimensional drawing	
Width	16.1 mm
Height	28.5 mm

Material specifications

Color	light gray (RAL 7035)
-------	-----------------------

Mounting

Thread type	()
-------------	----

TMC 7 B1 TERM - Terminal adapter

1022233

<https://www.phoenixcontact.com/us/products/1022233>



Drawings

Dimensional drawing

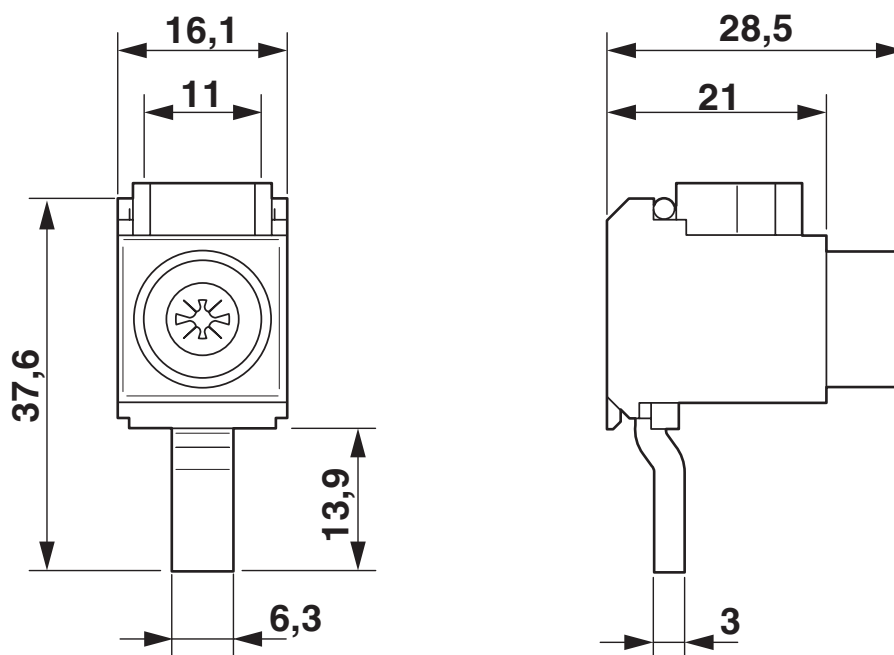

TMC 7 B1 TERM - Terminal adapter



1022233

<https://www.phoenixcontact.com/us/products/1022233>

Approvals

To download certificates, visit the product detail page: <https://www.phoenixcontact.com/us/products/1022233>



UL Listed

Approval ID: E123528



cUL Listed

Approval ID: E123528

cULus Listed

TMC 7 B1 TERM - Terminal adapter



1022233

<https://www.phoenixcontact.com/us/products/1022233>

Classifications

ECLASS

ECLASS-11.0	27144037
ECLASS-12.0	27144037
ECLASS-13.0	27144037

ETIM

ETIM 9.0	EC001513
----------	----------

TMC 7 B1 TERM - Terminal adapter



1022233

<https://www.phoenixcontact.com/us/products/1022233>

Environmental product compliance

EU RoHS

Fulfills EU RoHS substance requirements	Yes, No exemptions
---	--------------------

China RoHS

Environment friendly use period (EFUP)	EFUP-E
	No hazardous substances above the limits

EU REACH SVHC

REACH candidate substance (CAS No.)	No substance above 0.1 wt%
-------------------------------------	----------------------------

Phoenix Contact 2024 © - all rights reserved
<https://www.phoenixcontact.com>

Phoenix Contact USA
586 Fulling Mill Road
Middletown, PA 17057, United States
(+717) 944-1300
info@phoenixcon.com